

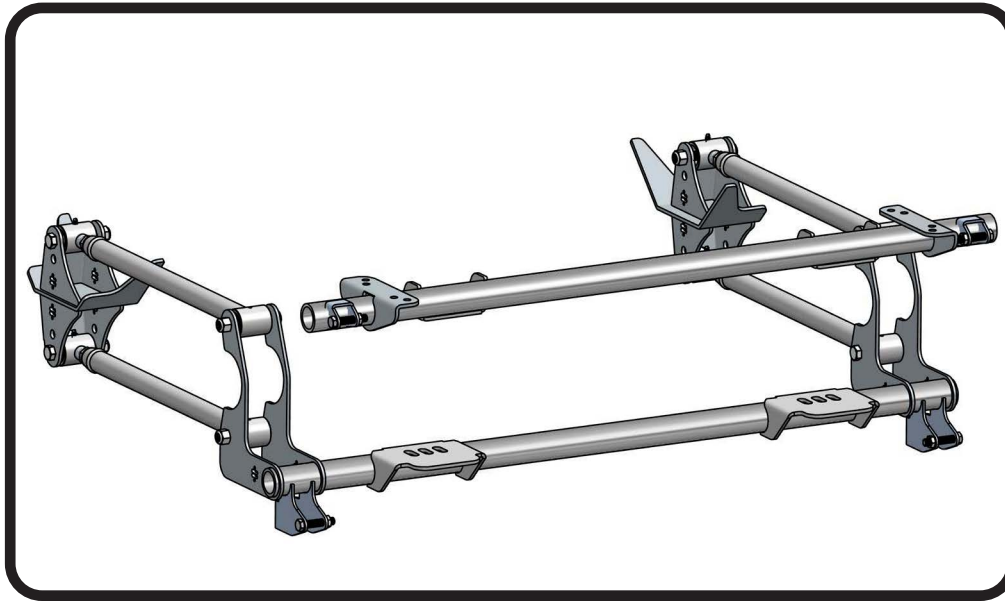

Part # 11006797(3" Axle)/**11006798**(3 1/2" Axle)/**11006799**(4" Axle)

HD Universal Parallel 4-Link



Recommended Tools

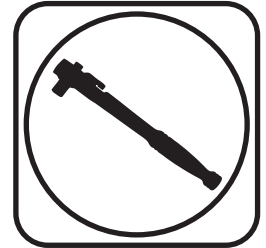

Heavy Duty Universal Parallel 4-Link Installation Instructions

Table of contents

Page 2.....	Included components
Page 3.....	Hardware List & R-Joint Spacer Installation
Page 4.....	Helpful Hints & Getting Started
Page 5.....	Setting Pinion Angle
Page 6-7.....	Parallel 4 Link Installation

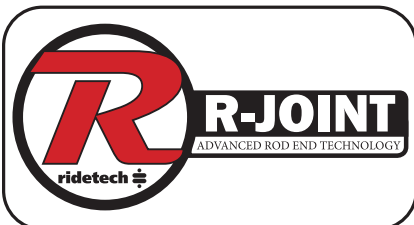



Major ComponentsIn the box

Item #	Part #	Description	QTY
1	70010835	4 link bar frame bracket – Driver side	1
2	90001327	R-Joint XL Housing	4
3	70014476	4 link bars	4
4	AXLE PLATES VARY WITH KIT DEPENDING ON MAIN KIT #		
	70010830	Axle plates for 4" Axle Tubes- included in kit # 11006799	4
	70011762	Axle plates for 3 1/2" Axle Tubes - included in kit # 11006798	4
	70011763	Axle plates for 3" Axle Tubes - included in kit # 11006797	4
5	70010841	52" long 2" diameter bridge tubes	2
6	70010831	Upper bridge frame bracket	2
7	70010834	4 link bar frame bracket – Passenger side	1
8	90000274	Lower bridge airspring mounts	2
9	90000273	Upper bridge airspring mounts	2
10	70008191	Upper bridge shock mounts	2
11	70009802	Lower bridge shock mounts	2
12	90002107	3500lb AirSprings (Not Shown)	2
13	90000272	4 link bar bungs	4
14	70013858	R-Joint Spacers	16
15	90001082	Short bumpstop (Not Shown)	2
	R-Joint Components - assembled in bars and rod ends		
	70013631	Retaining Ring	8
	70013630	Wavo Wave Spring	8
	70013629	Center Pivot Ball	8
	70013628	Composite Cage	8

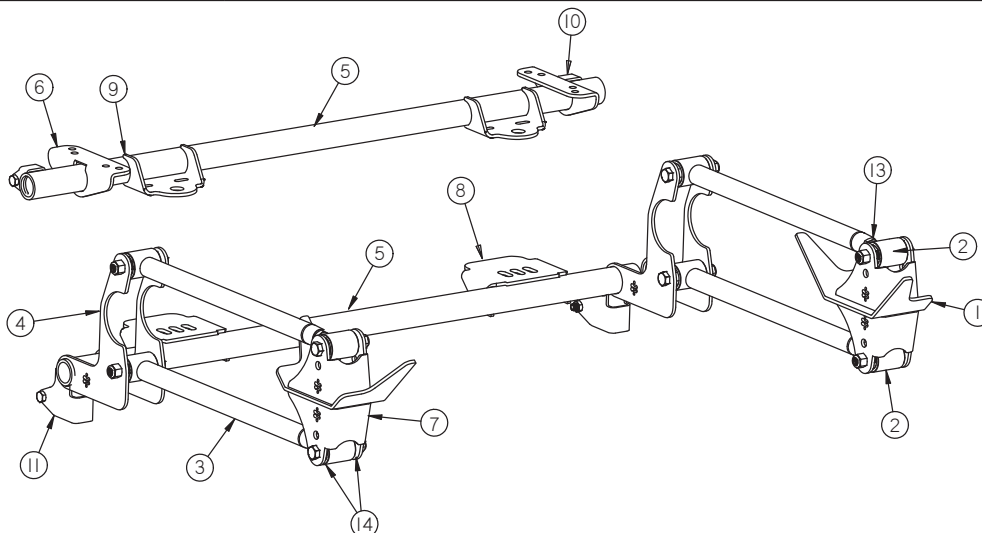



Hardware ListIn the box (Kit# 99010051)

The Hardware Kit contains bags to help aid in selecting the correct hardware for the component being installed. The hardware list shows how the hardware is bagged.

QTY	Part Number	Description	QTY	Part Number	Description
4 LINK BAR MOUNTING			SHOCK MOUNTING		
4	99952001	1"-14 Jam Nut	4	99501003	1/2"-13 X 2 1/2" Hex Bolt
8	99621010	5/8"-18 x 4" Hex Bolt	4	99502001	1/2"-13 Nylok Nut
8	99622001	5/8"-18 Nylok Nut	UPPER AIRSPRING MOUNTING		
1	90002276	Anit-sieze	4	99371003	3/8"-16 x 1" Hex Bolt
LOWER AIRSPRING MOUNTING			4	99373005	3/8" Split Lock Washer
4	99501001	1/2"-13 X 1" Hex Bolt	4	99373003	3/8" SAE Flat Washer
4	99503002	1/2" Split Lock Washer	BUMP STOP MOUNTING		
4	99503001	1/2" SAE Flat Washer	2	99372002	3/8"-16 Nylok Nut
			2	99373003	3/8" SAE Flat Washer

R-Joint Spacer Assembly

R-JOINT SPACER INSTALLATION

Install the Spacers by inserting the SMALL side of the SPACER into the Center Pivot Ball. Push them in until they bottom out and stop.

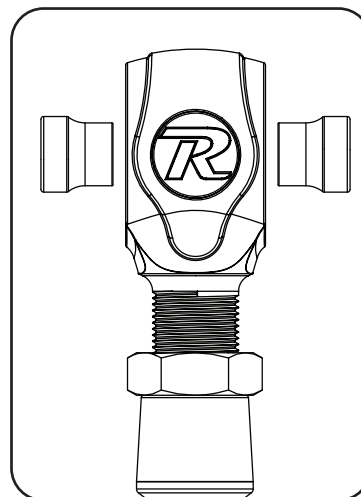

New R-Joints will be quite stiff (75-90 in/lbs breakaway torque) until they "break in" after a few miles of use. After the break in period they will move much more freely. Because the composite bearing race contains self lubricating ingredients, no additional lubrication is needed or desired. Any additional lubrication will only serve to attract more dirt and debris to the R-Joint and actually shorten its life.



Helpful Hints

1. Determine the Axle centerline. (Do this before you remove the bed)
 - a. If you are getting ready to start on a driving vehicle your centerline will usually be straight up from the existing location. One thing you will want to look at is the wheel and tire location in the wheel opening, it should be centered in the opening at ride height.
 - b. Once the axle centerline is determined you will want to put a mark on both frame rails for reference. We like to find a common reference on both sides to measure from. Some that we use are the leaf spring hangers, hanger holes in the frame.
2. Determine Ride and Compressed Heights
 - a. On a HD truck you will want 3.0" to 3.5" of suspension compression to achieve good ride quality. The airspring supplied with this kit has a minimum compressed height of 6.5", you will want to run a minimum of 6.75" to keep from pinching the airspring. This will give you a useable compression stroke of 3.75".
 - b. If you are matching the existing height measure between the top of the axle (or bumpstop pad if equipped) and the frame rail and write down for later referencing.
 - c. If you are looking to lower the truck= Measure between the axle and frame and subtract the amount you want to lower it. If you do not have 3.0" to 3.5" of compression travel you will need to either shoot for a taller ride height or C-notch the frame.
 - d. Somethings you want to keep in mind or watch out for when determining the height.
 - i. If you are looking to lower the truck how low can the front suspension go. You are usually more limited by the front suspension than the rear.
 - ii. What obsticals are above the rearend. The center of the rearend is usually the highest part of the rearend and will usually hit the bed floor or frame before the axle tube do.

Getting Started.....

1. If you are starting from scratch, set the vehicle up at a comfortable working height and place the rear-end under the car at ride height. Keep in mind that with an air ride system you will be able to drop the car approx. 3" to 3.5" from this height by deflating the system.
2. Center the rear-end side to side in relation to the frame. This is usually done by measuring from the frame to the wheel mounting or bearing flange of the rear-end and making these measurements equal.
3. Center the rear-end in the wheel openings. The rough position should be centered in the wheel openings, but the final adjustment should make sure that the rear-end is square to the frame and that the distance between the axle centerlines [front to rear] are equal on each side of the car.
4. The pinion angle should be roughly set parallel with the transmission. This will allow you enough adjustment to fine tune the pinion angle when the installation is complete. The next page has some information on pinion angles.



Setting Pinion Angle

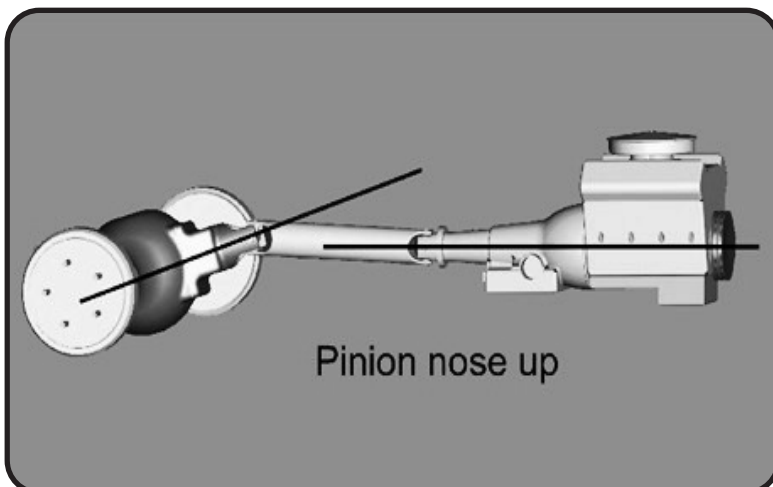
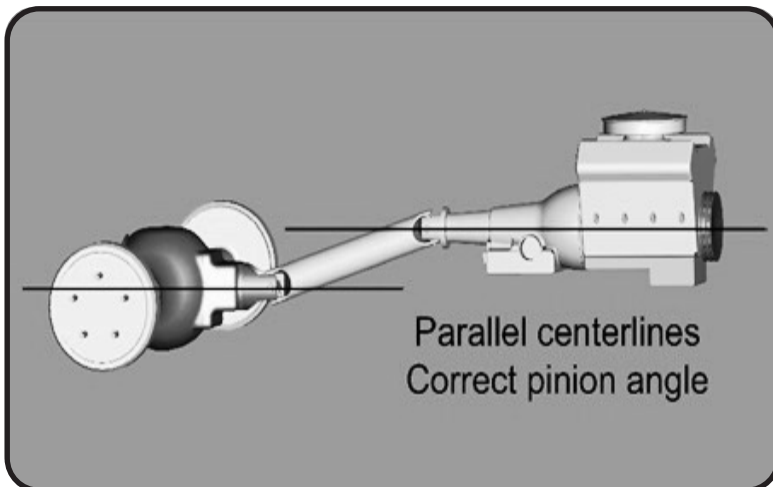
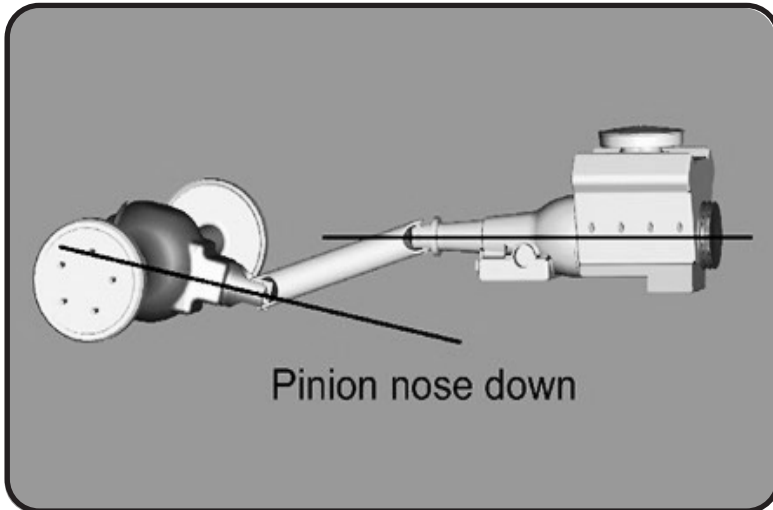

How do you set the pinion angle? On a single-piece shaft you want to set it up where a line drawn through the center of the engine crankshaft or output shaft of the transmission and a line drawn through the center of the pinion are parallel to each other but not the same line.

Your transmission angle should be around 3 degrees down in the rear. If it is more or less than 3 degrees, you might want to consider changing it. Too little angle on the transmission reduces the amount of oil getting to the rear bushing. Too much transmission angle will increase the working angles of the u-joints which will increase the wear. With the transmission at 3 degrees down in the rear, you will want to set the pinion 3 degrees up in the front.

A simple way to do this is to place a digital angle finder or dial level on the front face of the lower engine pulley or harmonic balancer. This will give you a reading that is 90 degrees to the crank or output shaft unless you have real problems with your balancer. At the other end, you can place the same level or angle finder against the front face of the pinion yoke that is also at 90 degrees to the centerline. If you rotate the yoke up or down so both angles match, you have perfect alignment.

Road testing will tell you if you have it right. If you accelerate and you get or increase a vibration, then the pinion yoke is too HIGH. Rotate it downward in small increments of a degree or two until the problem goes away. If you get or increase a vibration when decelerating, then the pinion yoke is too LOW. Rotate it upward to correct it.



Parallel 4 Link Installation

5. Steps 2,3, and 4 may have to be double checked and repeated to ensure the rear-end is correctly placed under the car. When you are satisfied with the placement, make sure the rear-end won't move during installation. [We tack weld a spacer in between the frame and the axle tube.]

6. Now you have to determine what is going to be the best location for the bar mounts(7)(14) and also the bar length. Refer to the paragraph below to help with bar length setup. The bar mounts(7)(14) can be mounted on the inside or outside of the frame, since the kit is designed for a Heavy Duty kit, outside of the frame would be best.

Bar Length

This kit comes with bars that are designed to be cut to length. The can be run up to 36" center to center. The goal is to run the longest bar that is possible. We know that things like gas tanks and bed braces can get in the way, which is the main reason behind cutting the material to fit. We provided a drawing to give you an idea of the initial setup of the bars. You will need to measure to see what your bar length will need to be. One way to do this: After you have your rear-end set in the truck, hold the frame bracket up to the frame in the location where it will be installed, measure from the center of the bar bolt to the front of the axle, now take this dimension and add 2.0" this will give you the approximate center to center of the bars. Now measure from the center of the bushing that is already welded to the bar and put a mark where the center of the other bushing would be, from this mark measure back 4 3/8" and mark the tube, this is where you will cut the tube. Once the tube is cut thread 1" jam nut(13) onto the rod end(2) into the bar bung(3) and verify your center to center before welding. You should have approximately 3/8" of thread showing

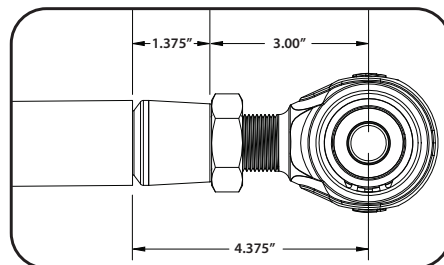

7. When the rear-end is correctly placed, the lower bracket /bar assembly can be placed. The 4 link kit is installed with the lower bars beside the frame either inside or outside. To determine the proper location, assemble the axle bracket(4), upper and lower bar, and the frame bracket together(7)(14) and place the lower axle bracket against the axle tube. With the lower bar level with the car, determine the best location for the frame bracket against the frame.

8. When the lower frame bracket location has been determined, tack them into place. [Don't weld fully yet]

9. Place the axle brackets(4) onto the axle tube at the same distance apart as the lower frame brackets. The spacing of these can be held using the bars. The back of these brackets should be plumb, [Perpendicular to the ground] and must be level with each other! This will ensure that the lower 4 link mounting points are even from front to back. Sliding one of the crossmember tubes(5) through the back of the brackets will aid you in lining them up and give you a way to check and make sure everything is parallel from side to side. (Meaning the Axle, Frame, and crossmember are all level with each other.

10. Now is the time to install the panhard kit you ordered from Ridetech using the instructions that came with the Panhard kit.

11. At this point we like to cut the spacers out between the axle and frame. With a floor jack, raise and lower the rear-end through its travel to check for interference or binding of the rod ends. If the rear-end moves freely, you can move on the bag and shock installation. Note: that the movement may be somewhat stiff due to the R-Joints being new.



Parallel 4 Link Installation

12. Put the ride height spacers back in between the axle and frame, this is the height you will installing the Air Springs at ride height. The ride height of the Air Springs included in this kit is 10 ½" with a maximum diameter of 9". The working dimensions of the Air Spring are: 6 ½" compressed (you should allow an extra ¼" to keep from pinching the Air Spring at full compression) 10 ½" ride height, 13" full extension (the shock should be used to capture the Air Spring).

13. The Air Spring mounts [lower(8) upper(9)] should be parallel with each other at ride height and also lined up from left to right, and front to back (the mounts are slotted front to back to allow some adjustment in that direction).

14. The lower crossmember height is determined by the axle brackets. The crossmember tubes are a universal length that will most likely need to be cut to fit your application. The upper crossmember and Air Spring mounts(9) has some mounting options to achieve the proper Air Spring installed height. We have included some drawings below to give you some ideas. We normally start out by holding the lower Air Spring mount (8) onto the crossmember to help in locating the best location for mounting the Air Spring. We look for what is going to give the best clearances of the Air Spring. Keep in mind the maximum diameter of 9".

Tip: We make a spacer that is 10 ½" tall to simulate the height of the Air Spring, this can be made out of a wood 4 x 4 with the center marked on each end to help keep the mounts lined up front to back, and left to right.

These are variations that the upper cross member can be mounted.

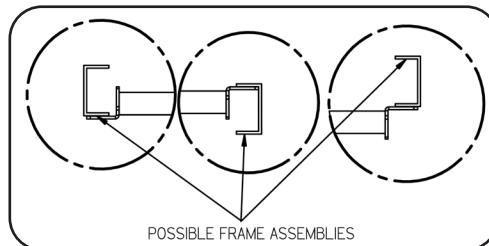

15. The upper bag mount (9) can be mounted off the front or rear of the upper crossmember.

16. Once the bag mounts height and location is determined, tack weld them in place.

Tip: One way to keep the left and right Air Spring mounts parallel with each other is to tack one side in place and use a piece of angle clamped to it to help line up the other one.

17. After the Air Spring mounts are tack welded in place it is a good idea to run the suspension through its travel to check yourself.

18. Now that your Air Spring mounts are tacked in, it is time to install the shock setup.

19. Check the dimensions of the shocks that you have (Generally we would run a 6" stroke shock with this setup). The goal is to optimize the shock travel with the Air Spring travel. We set them up to where at full compression there is ¼" of shock compression left and the shock hits full extension at the same time as the Air Spring hits full extension (13"). You will have to run the suspension through its travel to be able to do this step.

20. The kit comes with upper (10) and lower (11) shock mounts designed to be welded to the crossmember tubes. These mounts can be mounted to the front or rear of the crossmember which ever location works the best to optimize the stroke of the shock with the suspension travel.

21. Now that you have everything tacked in place, run the suspension through its travel one more time. If it all looks good with no clearance issues, it is time to start welding. When welding on the axle tubes we like to weld 1 inch at a time moving from one side to the other trying to keep from getting too much heat into the axle tubes. Also remove the 4 link bars before welding to keep from damaging the R-Joints.