



2024 Ford Mustang
RTR Duck Bill Spoiler
Part Number 11011.0009.12.A

Components Included

- | | | |
|----|-----------------------|---|
| 1. | RTR Duck Bill Spoiler | 1 |
| 2. | Camera Retainer | 1 |
| 3. | Hardware Pack | 1 |
| 4. | Instruction Scan Card | 1 |

NOTE – In addition to common hand tools, installation of this part requires the use of the following:

- 3M™ General Purpose Adhesive Cleaner
- Isopropyl Alcohol
- Adhesive Eraser Wheel and a Hand Drill

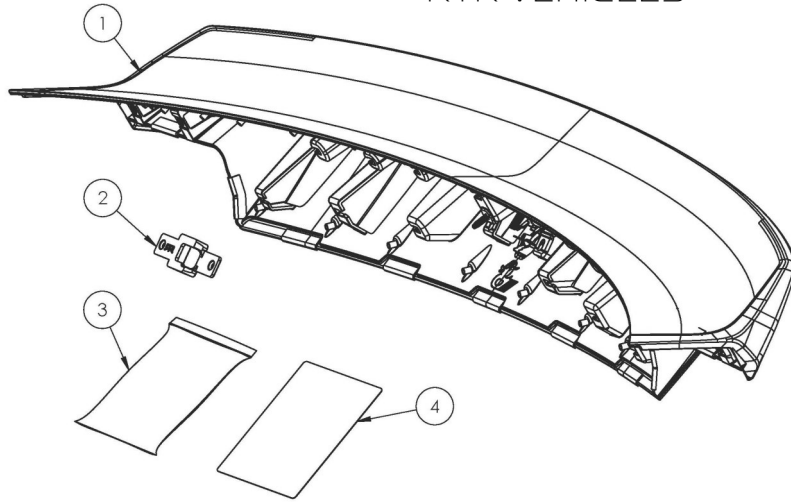

These instructions depict an installation being performed on a Mustang GT, Performance Pack 3. While some installation details may vary from model to model, the general procedure remains the same. Disregard any information that does not apply to your model.



1. Raise the trunk lid and remove the emergency release handle from the trunk lid liner.

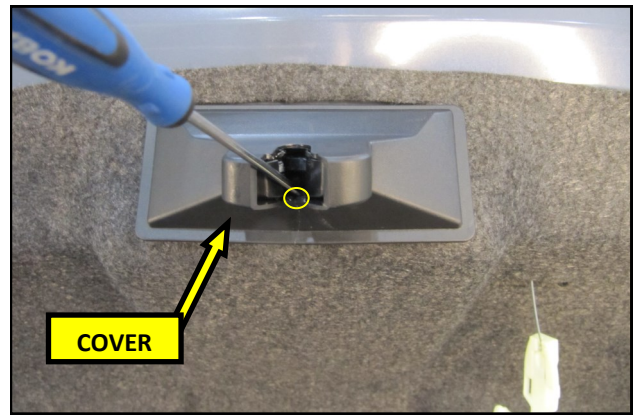

2. Remove Using a small screwdriver, pry the bottom of the truck latch cover away from the latch and remove it from the vehicle.

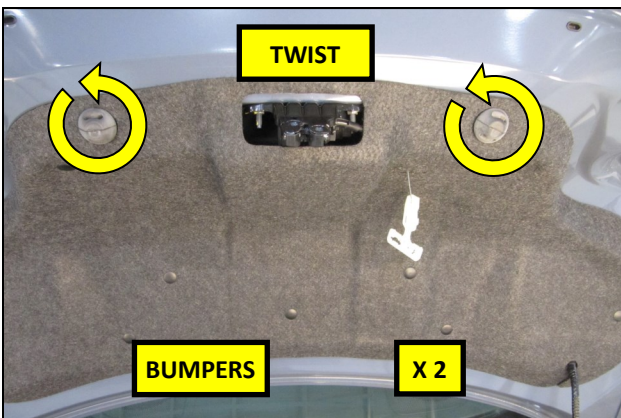

3. Remove the trunk lid bumpers and set them aside.

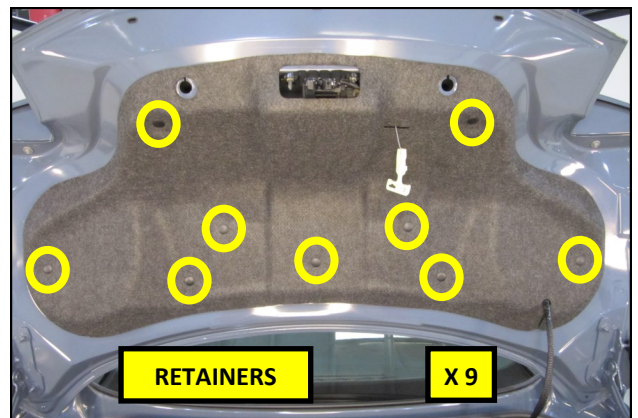

4. Using a panel trim removal tool, pry the 9 retainers from the liner.

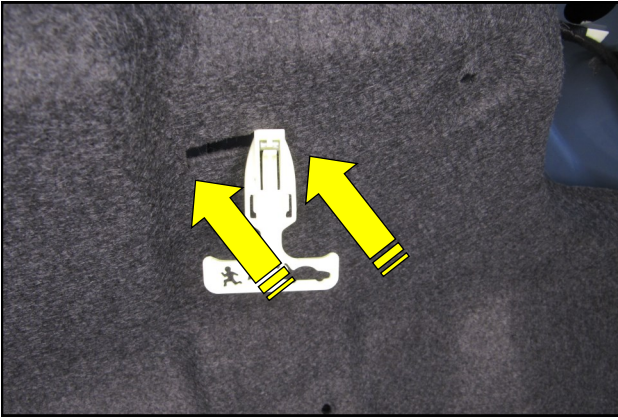

5. Push the release handle through the opening in the liner.

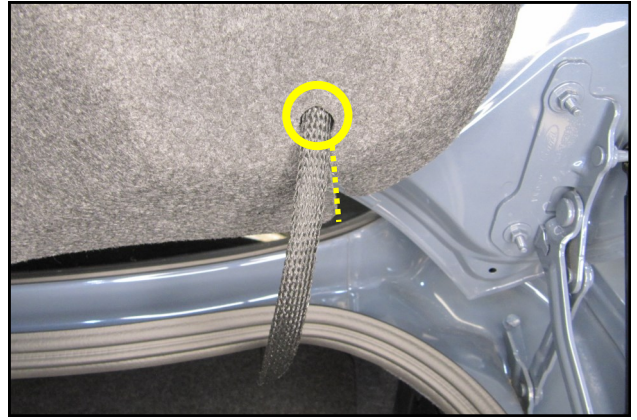

6. Pull the wiring harness out of the liner and remove the liner from the vehicle.

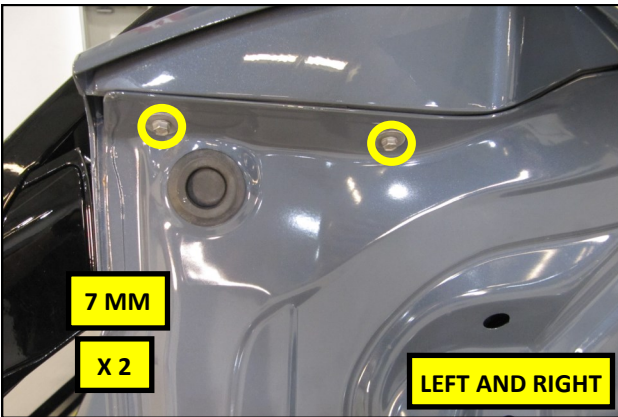

7. Using a 7 MM socket, remove the two screws on both sides of the trunk lid.

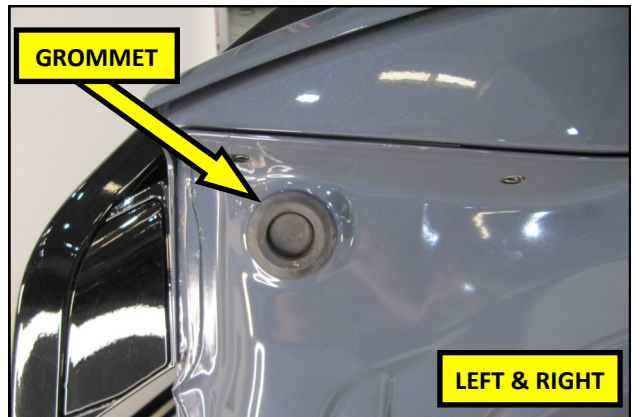

8. Pry the blind grommets out of the trunk lid and set them aside.

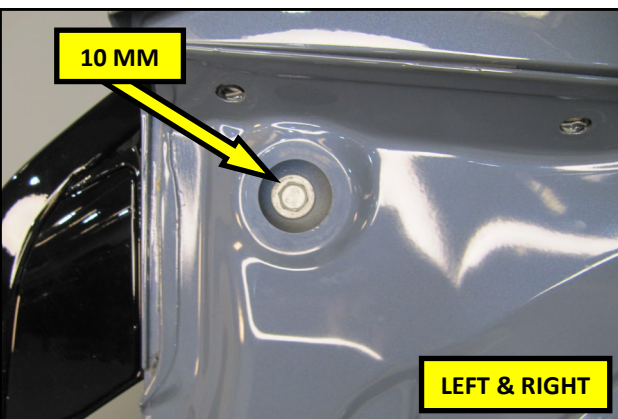

9. Using a 10 MM socket, remove the bolts from both ends of the trunk lid and lower the trunk lid.

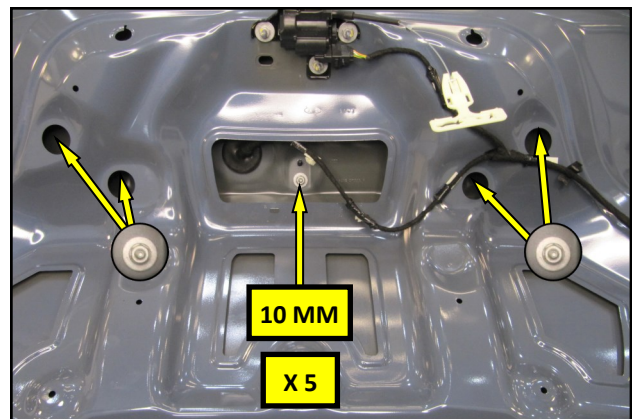

10. Using a 10 MM socket, remove the five flange nut in the trunk lid. **NOTE:** Special care should be taken to avoid dropping the nuts into the trunk lid.

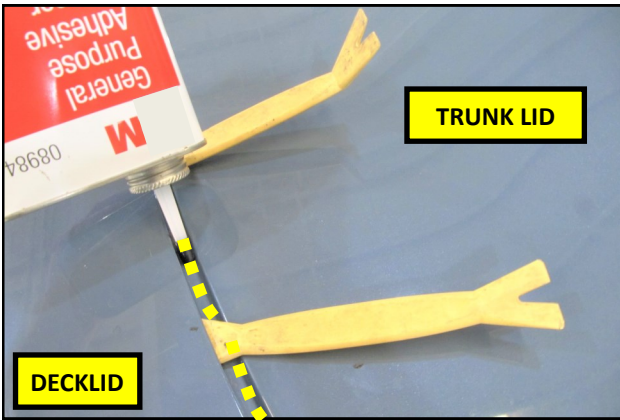

11. Saturate the adhesive at the leading edge of the decklid with adhesive cleaner. When the adhesive has fully softened, carefully pry the deck lid off of the trunk lid using plastic trim tools.

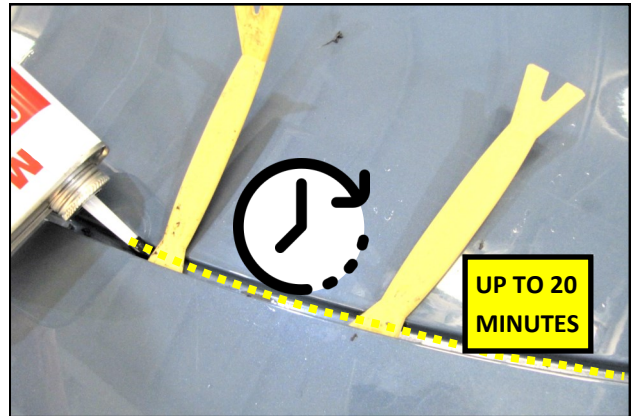

NOTE: depending on the age of the adhesive on the vehicle, this may require considerable effort to remove. Allowing the solvent to act for as long as 20 minutes will ease this process. Multiple applications may be necessary.

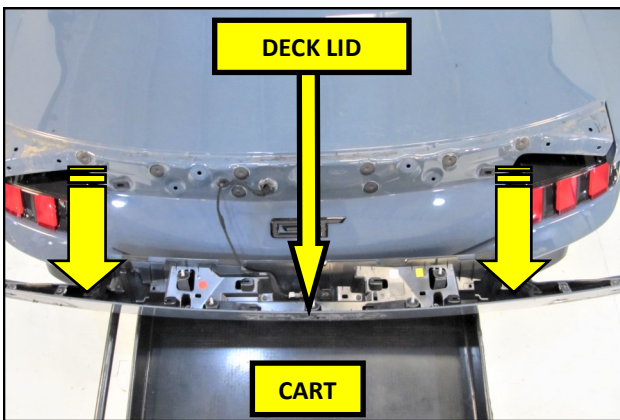

12. Remove the deck lid from the vehicle and set it onto a tool cart or similar.

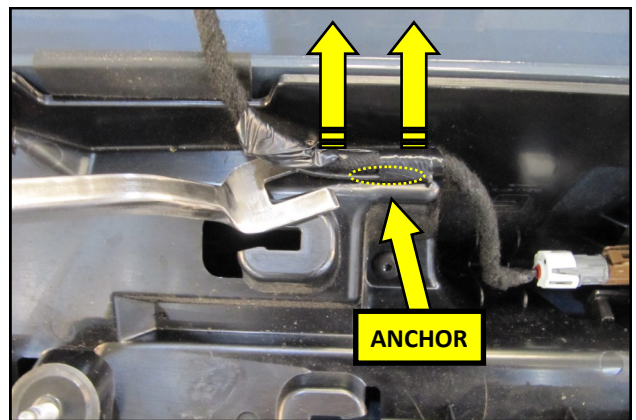

13. Using a panel clip removal tool, pry the harness anchor out of the deck lid.

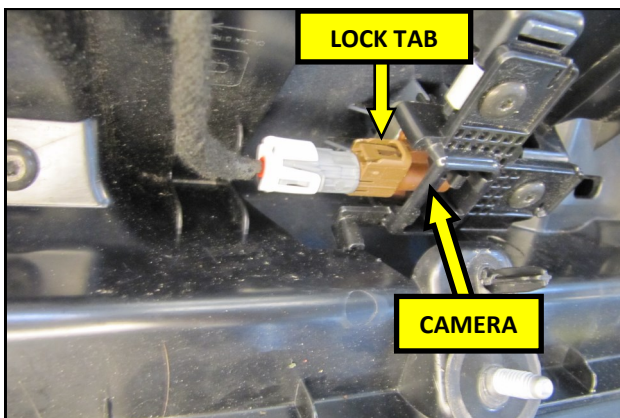

14. Depress the lock tab on the camera connector and disconnect the harness from the camera.

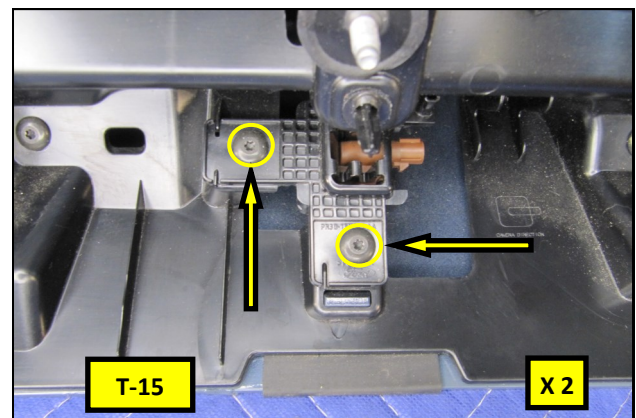

15. Place the decklid, face down, onto a padded work surface. Using a T-15 Torx driver, remove the two screws in the camera bracket.

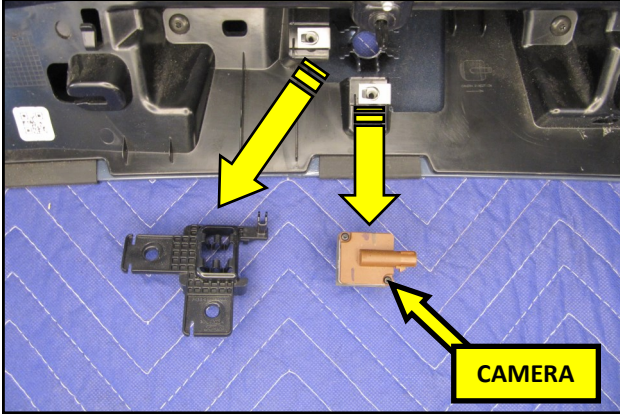

16. Remove the camera and bracket from the deck lid.

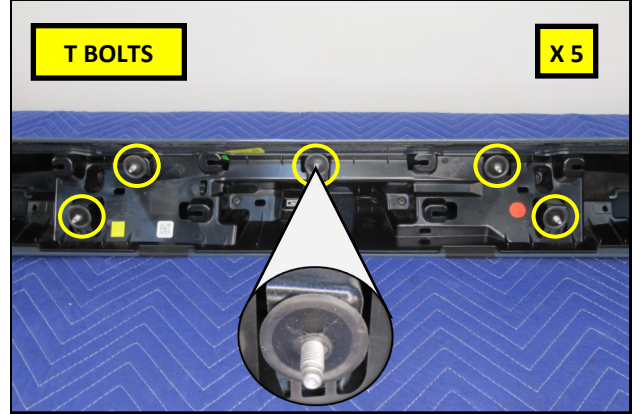

17. Slide the 5, T bolts out of the deck lid and set them aside.

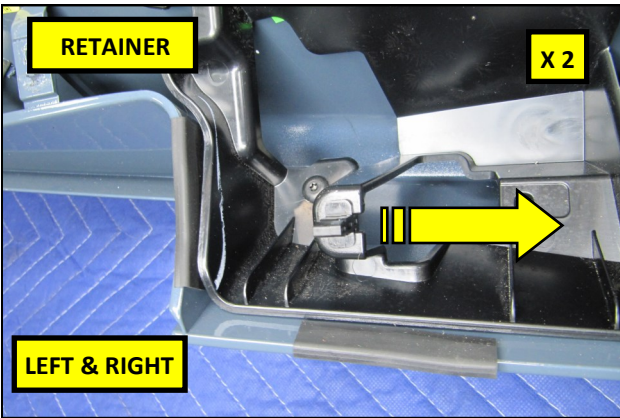

18. Slide the two retainer clips out of the deck lid and set them aside.

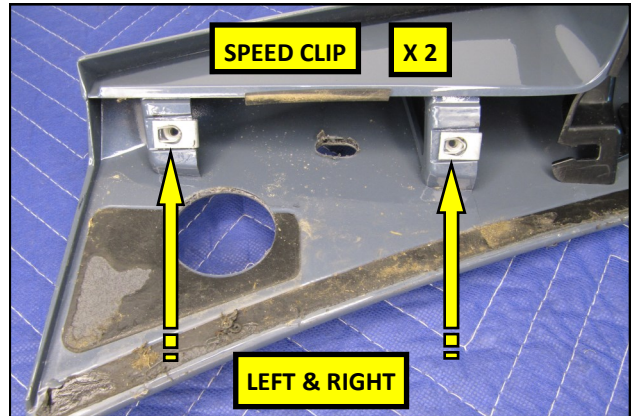

19. Remove the speed clips at each end of the deck lid and set them aside.

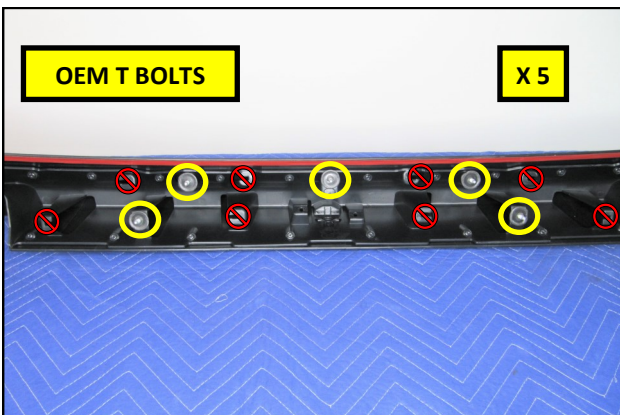

20. Transfer the T bolts from step into 17 into the RTR Spoiler.

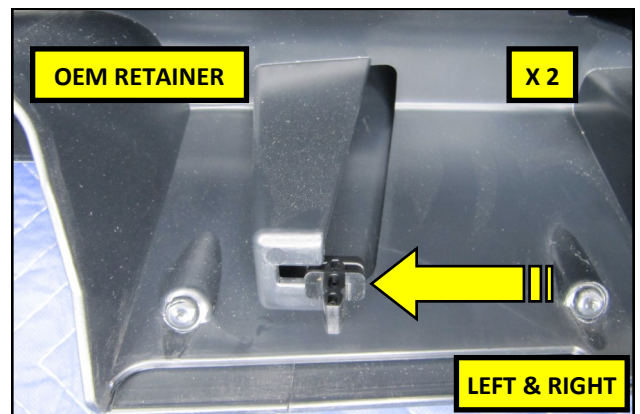

21. Transfer the retainer clips from step into 18 into the RTR Spoiler.

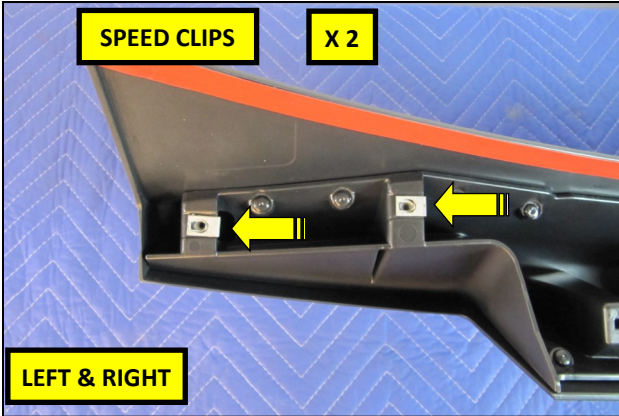

22. Reinstall the OEM speed clips from step 19 onto both ends of the RTR Spoiler.

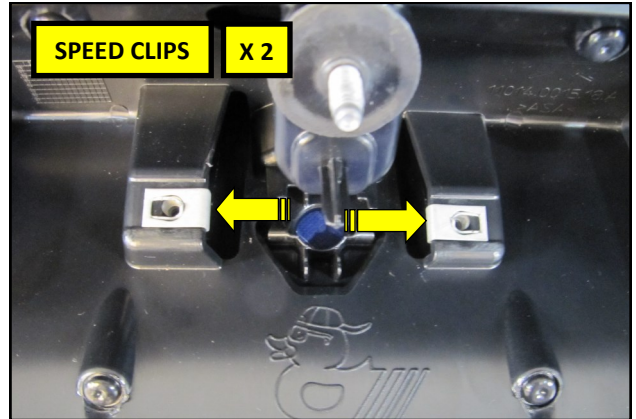

23. Install two supplied speed clips from the hardware pack, onto the center of the RTR Spoiler.

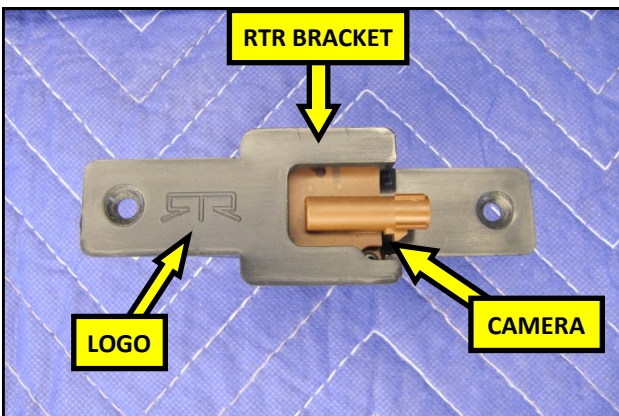

24. Place the RTR Camera Bracket onto the OEM camera, as shown. **Note:** When properly installed, the camera connector is pointing away from the RTR logo on the bracket.

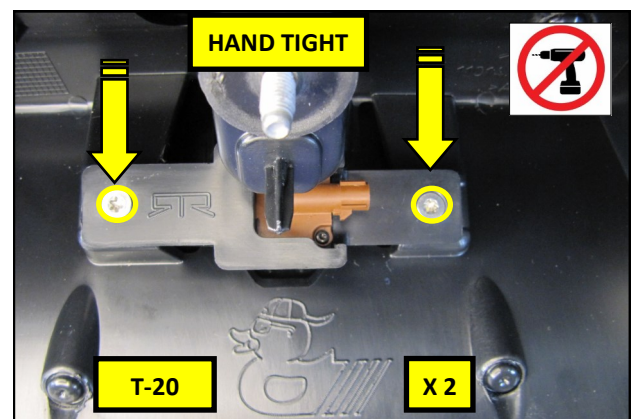

25. Place the camera and Bracket into the center of the RTR Spoiler as shown. Using a T-20 Torx driver and the supplied M4 Screws, secure the camera and bracket to the spoiler. Tighten the screws by hand to avoid over tightening.

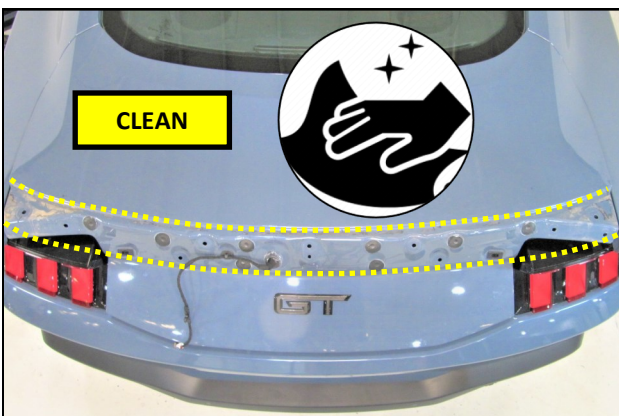

26. Using a mild solution of soapy water and a microfiber towel, remove any and all dirt that may have accumulated underneath the decklid.

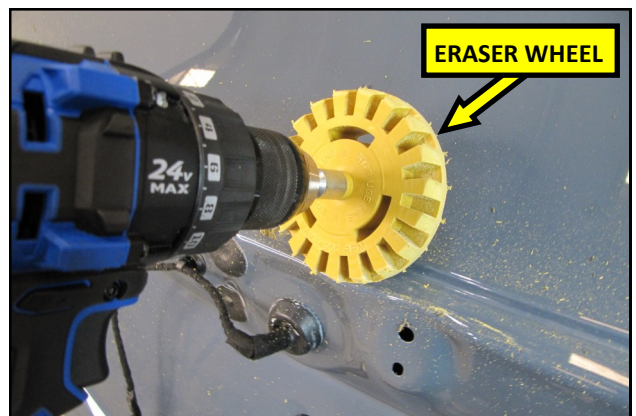

27. Using a rubber eraser wheel and a drill, remove any remaining adhesive on the trunk lid.

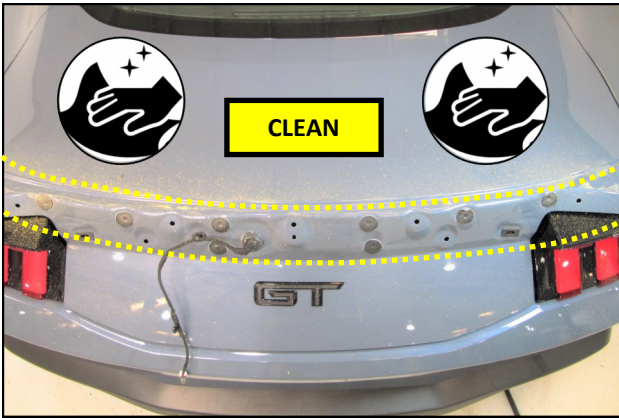

28. Using a dry microfiber cloth, wipe away the eraser dust and any adhesive remnants.

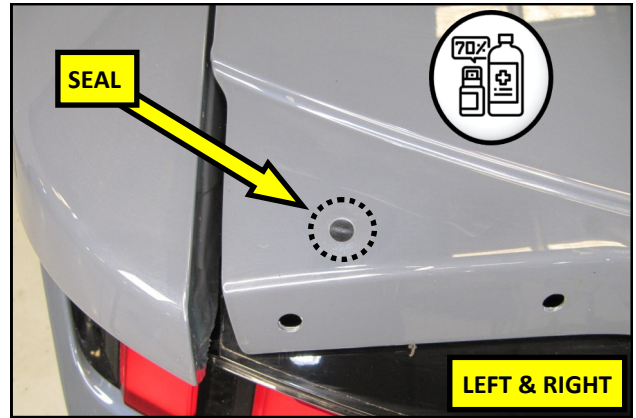

29. Using isopropyl alcohol, thoroughly clean the trunk lid surrounding the spoiler bolt holes. Carefully apply the Sealing Discs over the bolt holes as shown.

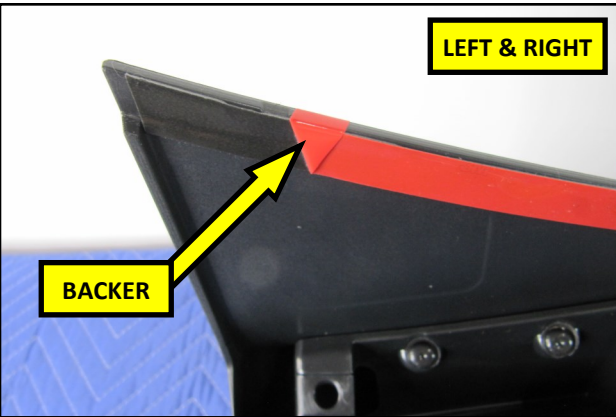

30. Peel back approximately 1 1/2 inch of the tape backer on both ends of the RTR Spoiler and fold it over as shown.

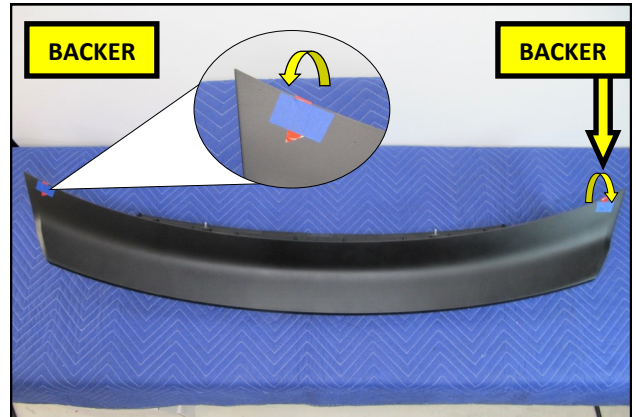

31. Tape the ends of the tape backer onto the top side of the RTR Spoiler as shown.

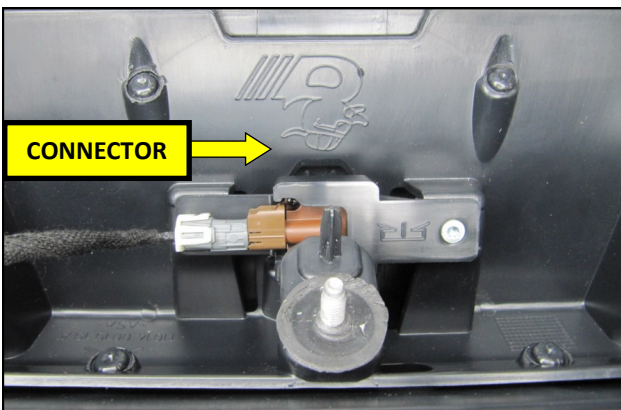

32. Place the RTR Spoiler onto a padded tool cart near the vehicle and reconnect the camera harness.

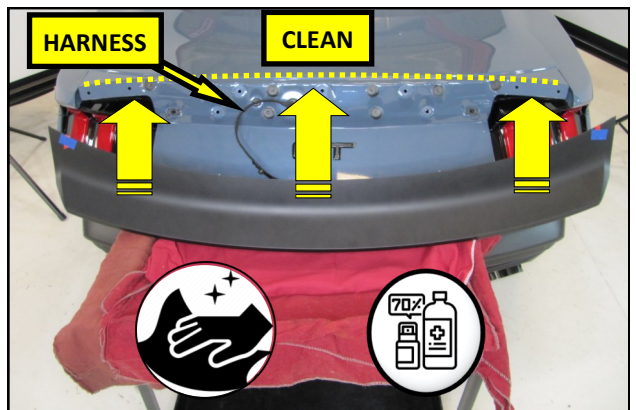

33. Clean the trunk lid, one last time, using isopropyl alcohol. Align the T bolts with the holes in the trunk lid and slide the RTR Spoiler onto the vehicle. Any resistance to fully seating onto the vehicle is an indication that the wiring may be positioned incorrectly. **Verify that the wire harness is not pinched before proceeding.**

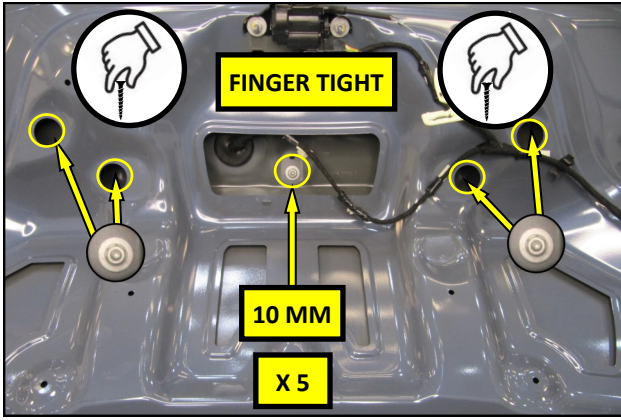

34. Attach the Spoiler to the trunk lid using the OEM flange nuts removed in step 8. Leave the fasteners finger tight at this time. **NOTE:** Special care should be taken to avoid dropping the nuts into the trunk lid.

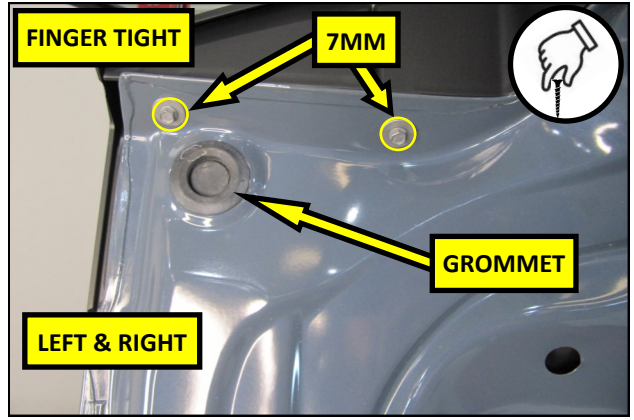

35. Secure the edges of Spoiler using the OEM screws removed in step 7. Leave the fasteners finger tight at this time. Reinstall the blind grommets into the trunk lid.

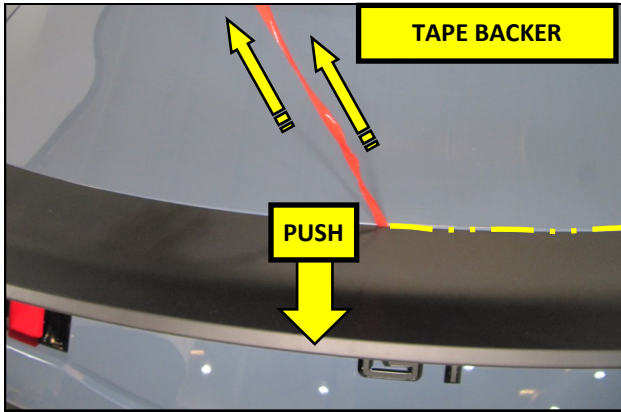

36. Carefully pull the tape backer out from underneath the Spoiler. **HINT:** If the backer becomes "trapped" and is difficult to pull, slight pressure may be applied to the rear of the spoiler to relieve tension on the tape and ease removal.

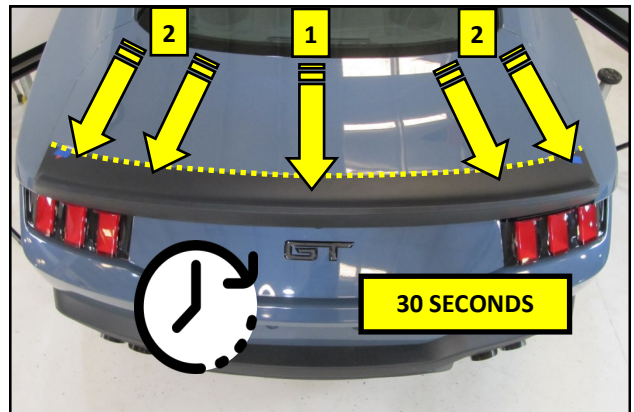

37. Press firmly onto the center of the Spoiler edge. Continue to work outward, pressing firmly towards the edges of the Spoiler. Continue pressure for a minimum of 30 seconds to achieve a strong bond.

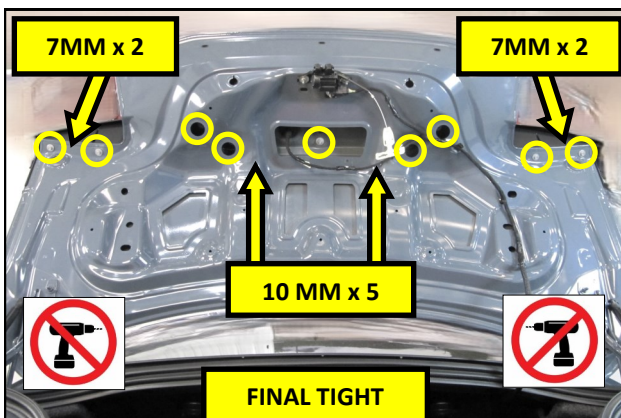

39. Tighten all of the fasteners from steps 35 and 36, final tight. Tighten all of the fasteners by hand to avoid overtightening.

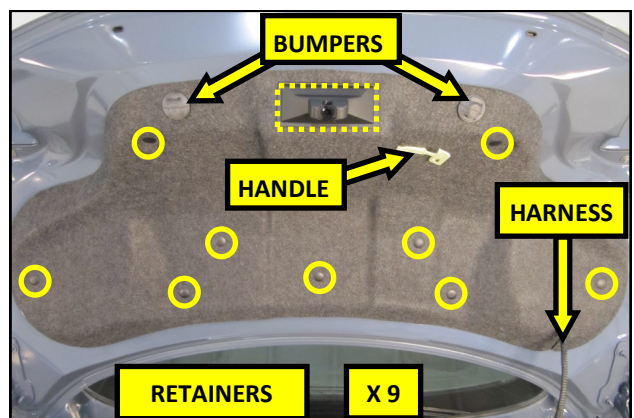

38. Pull the trunk release handle through the liner and install the bumpers to hold it in position. Reinstall the nine retainers into the trunk lid and pull the wire harness through the cut in the liner. Reinstall the trunk latch cover from step 2.