

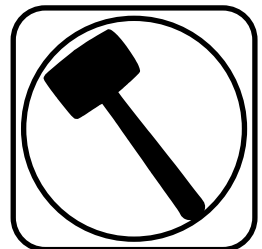

### Part # 11013699 - 1955-1957 GM B-Body Front Upper StrongArms



#### Recommended Tools



## 1955-1957 GM B-Body Upper StrongArms Installation Instructions

Table of contents	
Page 2.....	Upper Control Arm Components
Page 3.....	Getting Started & Installation
Page 4.....	Installing Spindle and Alignment



### Upper Control Arm Components .....In the box

Item #	Part Number	Description	QTY
1	90001292	Driver Upper Control Arm <b>(Shown)</b>	1
1	90001293	Passenger Upper Control Arm	1
2	90003041 kit	Tall Upper Ball Joint Kit - Proforged # 101-10477	2
3	90002695 kit	Cross Shaft Kit - contains 2 cross shafts	1
4	90001442	Delrin Bushing	4
5	90001288	Delrin Bushing Inner Sleeve	4
6	99373001	Outer Washer - Cross Shaft	4
7	99373005	3/8" Split Lock Washer -Cross Shaft	4
8	99371015	3/8"-24 x 1 1/2" Hex Bolt - Cross Shaft	4

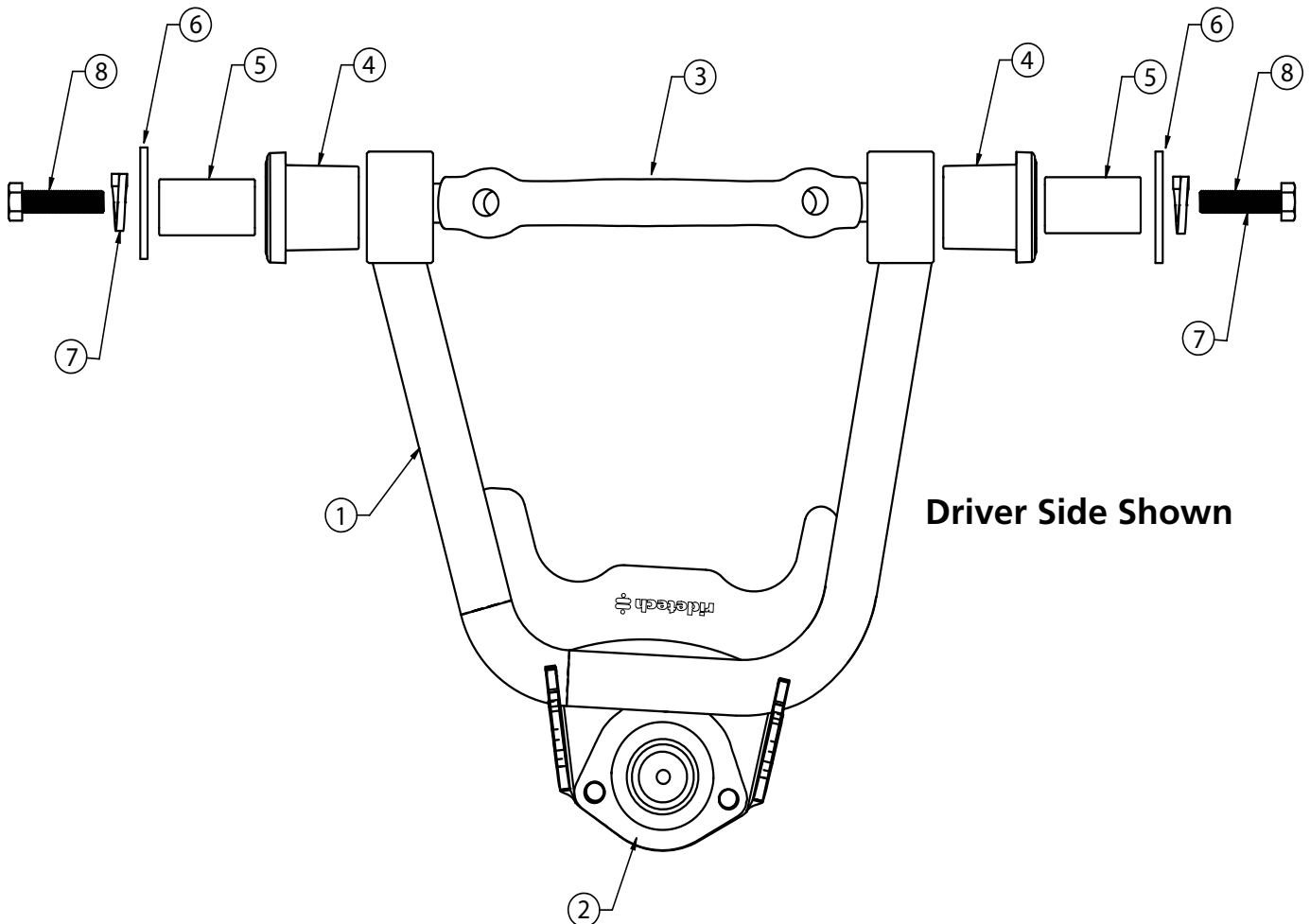



### Getting Started.....

Congratulations on your purchase of the Ridetech Tri5 StrongArms. These StrongArms have been designed to give your Tri5 excellent handling along with a lifetime of enjoyment. Some of the key features of the StrongArms: Ball joint angles have been optimized for the lowered ride height, Delrin bushings are used to eliminate bushing deflection along with providing free suspension movement through the entire travel. The Delrin bushings are made from a material that is self lubricating so no grease zerks are needed.

**When assembling the Control Arms tighten the cross shaft bolts enough to create drag on the delrin bushings, the arm should still move through its travel by hand.**

### Installation

1. Remove the upper control arms from the car. Keep the shims separate so that you can put them back in the location they were removed from. If you are replacing the lower control arms and spindle, remove them too. Refer to a Factory Service Manual for the proper method.

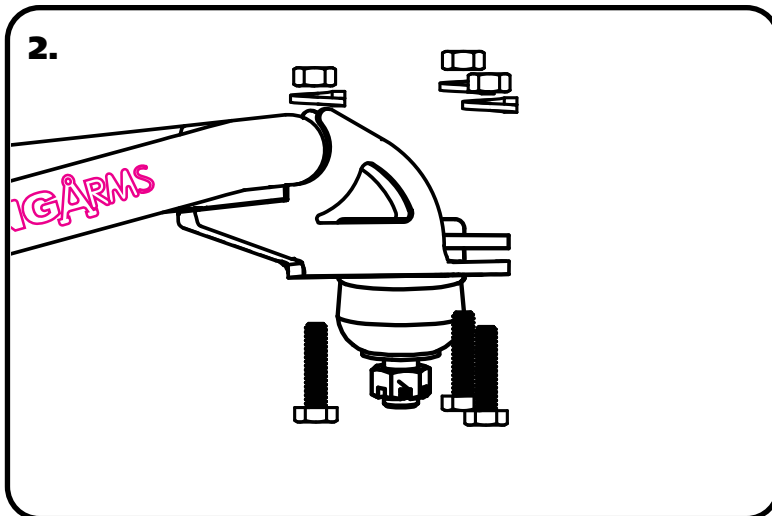

2. Insert the Ball Joint into the Control Arm from the TOP side with the Stud pointing downward. Insert the supplied Bolts from the bottom side. Install a Lock Washer and Hex Nut on the threads of each bolt. Torque the hardware to 18 ftlbs.

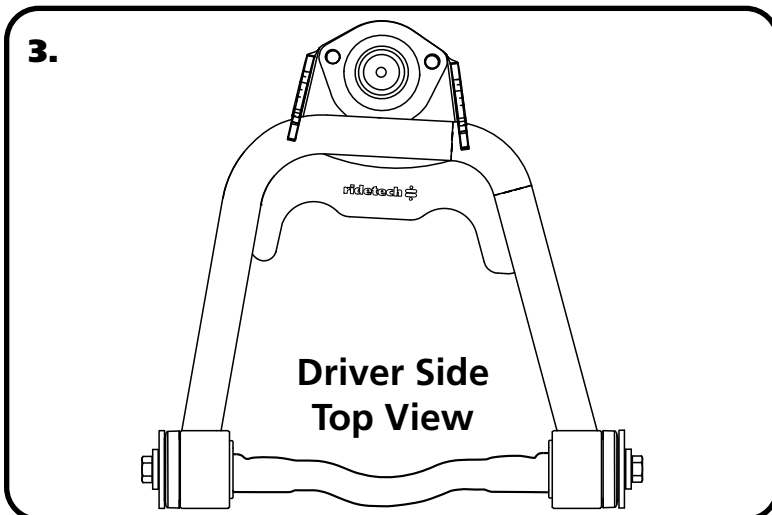

3. The Upper Control Arm is attached to the factory frame using factory hardware. The driver side arm is shown in **Figure "3"**. The Ball joint is located on the arm to the REAR of the car.



### Installing Spindle and Alignment



4. The Upper Control Arm is attached to the factory mount using factory hardware. Reinstall the shims in the location they were removed from. The passenger side arm is shown in **Figure "4"**. Torque the hardware 65-75 ft-lbs.



5. Attach the Spindle to the control arms.

**NOTE: DUE TO THE LONGER SHANK OF THE BALL JOINT, THE BALL JOINT BOOT IS DESIGNED TO SEAL ON THE BALL JOINT SHANK. IT DOES NOT SEAL AGAINST THE SPINDLE. A SEGMENT OF EXPOSED BALL JOINT STEM IS NORMAL.**

#### Torque Specs:

Ball joint - 45 ftlbs and tighten to line up cotter pin.

Install the Cotter Pin after tightening the ball joint nut.

6. Tighten all fasteners.

**When assembling the Control Arms tighten the cross shaft bolts enough to create drag on the delrin bushings, the arm should still move through its travel by hand.**

#### Suggested Alignment Specs:

Camber: Street: -.5 degrees  
Caster: Street: +3.0 to + 5.0 degrees  
Toe: Street: 1/16" to 1/8" toe in