

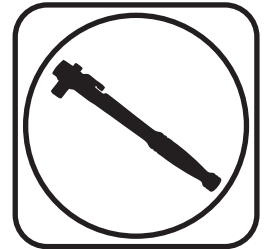

Part # 11014810 - 55-57 Chevy Car Composite Leaf Springs Kit with HQ Series Shock Kit



Recommended Tools



55-57 Chevy Composite Leaf Springs & Shock Kit

Installation Instructions

Table of contents

Page 2..... Included components and Hardware List

Page 3..... Leaf Spring Installation

Page 4..... Finalizing Installation

IT IS VERY IMPORTANT THAT NOTHING COMES IN CONTACT WITH THE COMPOSITE LEAF SPRINGS.

WILL NOT FIT WAGONS

www.ridetech.com





Major ComponentsIn the box

Part #	Description	QTY
90002908	Leaf Spring Blade Assembly w/70012456, 70012457, 90002547, & 90000519 installed	2
70012458	Leaf Spring Eyelet (Blade Assembly)	4
70012461	Delrin Rear Shackle Frame Bushing - 1/4" Flange	4
90002547	Inner Bushing Sleeve - 2.50" Front Leaf Spring, 1955 Rear Frame	2
90002569	Inner Bushing Sleeve - 3.50" 1956-1957 Rear Frame	2
90002555	Shackle Plate	4

Hardware Bag - Leaf Spring Kit

99501035	1/2"-13 x 5" Hex Bolt GR8 - Use with 3 1/2" Sleeve	2
99501034	1/2"-13 x 4 1/2" Hex Bolt GR8 - Use with 3" Sleeve	2
99501037	1/2"-13 x 4" Hex Bolt GR8 - Use with 2 1/2" Sleeve	4
99502009	1/2"-13 Nylok Nut GR8	6
99432009	7/16"-20 High Nut	8
99433005	7/16" Flat Washer GR8	8

Getting Started.....

IT IS VERY IMPORTANT THAT NOTHING COMES IN CONTACT WITH THE LEAF SPRING.

1. Jack the car up and support it by the frame rails. You will need to raise and lower the rear differential with a jack to ease installation. With the car supported by the frame, put the jack underneath the rear end housing and raise the jack up just enough to support the differential. Disconnect the bottom of the shock and remove the rear leaf springs. Retain the OEM hardware.
2. The Frame bushing is different depending on the year of the frame. 1955 uses a 2 1/2" Inner Sleeve, 1956 & 1957 utilizes a 3 1/2" inner sleeve.
3. The Shackle Plates and Hardware can be used to push the rear bushings and sleeves into the frame location. Start by inserting the correct length Inner Sleeve(1955 Uses a 2 1/2" Sleeve, 1956 & 1957 use a 3 1/2" Sleeve) into a Bushing from the inner side (opposite of the flange). Push the sleeve in until it is flush with the flange side of the bushing. Insert the bushing/sleeve into the shackle bushing hole. Insert a 2nd bushing half in the opposite side pushing it onto the sleeve as far as you can by hand. Insert a 1/2"-13 bolt into a shackle plate. Insert the bolt/shackle plate into the bushing/sleeve and install a second shackle plate on the threads sticking out of the bushing. Install a 1/2"-13 nut and tighten until the bushings bottom out on the frame.



Delrin Frame Bushing Installation

4.

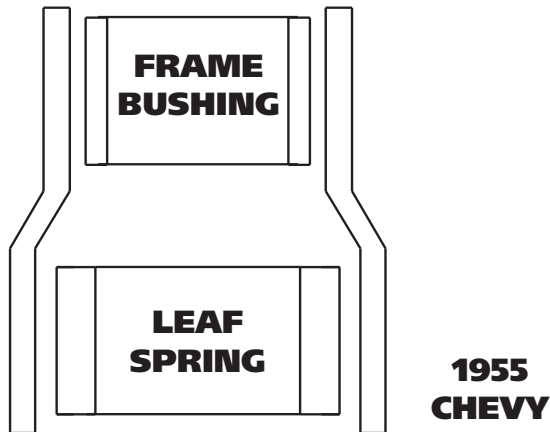

4. The orientation of the Shackle Plates is determined by the year of the car. The Frame bushing is 2 1/2" wide on a 1955, 3 1/2" wide on 1956-1957. 1955 is shown in Diagram "6". The 1955 uses 1/2"-13 x 4" in the FRAME bushing and 1/2"-13 x 4 1/2" in the REAR leaf spring bushing.

5.

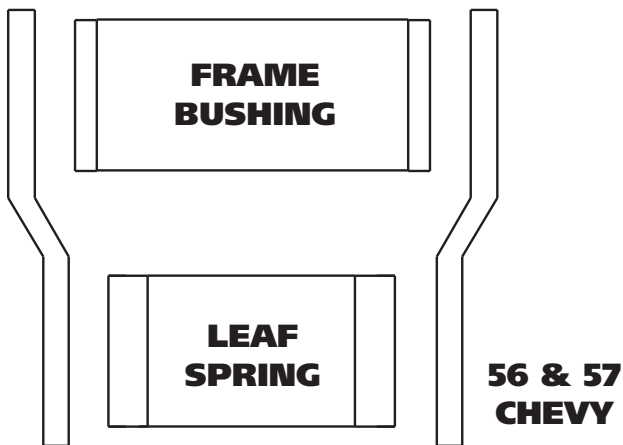

5. Diagram "5" shows the Shackle Plate orientation for 1956 & 1957. These cars use 1/2"-13 x 5" in the FRAME bushing and 1/2"-13 x 4 1/2" in the REAR leaf spring.

Note: ALL models use 1/2"-13 x 4" in the FRONT leaf spring bushing.

6.



6. Attach the rear of the Composite Leaf Spring(**WIDE BUSHING**) to the rear mount. If you are using the Ridetech Delrin Bushings, new Shackles and Hardware are supplied with them. Orientation of the Shackle Plates is shown in the Delrin Bushing instructions. Attach a Shackle Plate to each side of the Frame Bushing using the correct length 1/2" Bolt and 1/2"-13 Nylok Nut. Do not tighten. Align the remaining bolt holes in the shackle plates with the sleeve in the rear Leaf Spring bushing. Install a 1/2"-13 x 4 1/2" Bolt (WITH THREADS POINTING TO OUTSIDE OF CAR) and 1/2"-13 Nylok Nut. Do Not tighten hardware, it will get tightened later.



Leaf Spring Installation



7. Bolt the **NARROW BUSHING END** of the Composite Leaf Spring into the OEM front leaf spring mount using a 1/2"-13 x 4" Hex Bolt and 1/2"-13 Nylok Nut.

Note: You may have to jack the rear differential up enough to swing the leaf spring in place.



8. Lower the differential onto the Leaf Spring. Align the top PIN into the HOLE in the OEM leaf spring mount. Install the lower Clamping Plate/Shock Mount, supplied in the Staggered Shock Kit being sure the Pins and Holes are aligned. The Clamping Plates have the shock mounts built in, the driver mount is installed with the shock mount to the inside rear with the passenger installed with the shock mount to the inside front. Driver is shown in Diagram "6". Install the 7/16" U-Bolts.

9. Install a 7/16" Flat Washer and 7/16-20 Nylok Nut on each U-bolt. Evenly tighten the hardware by tightening in a crisscross fashion. Torque the nuts to 55 ftlbs.

Note: When tightening the mounts, pay attention to the pads on the springs to make sure there is visible compression of the pads. .030"- .060" of compression is needed for the springs to be securely mounted. All of the clamping force needs to be on the spring itself.

10. Tighten the Bushing hardware, torquing it to 75 ftlbs. The Delrin Bushings will not bind, so it isn't necessary to have the car at ride height. If using OEM style rubber bushings, the car will need to be on the ground at ride height before tightening the bushing hardware.

11. Install the Ridetech HQ Series shocks. Refer to the shock instructions.



Part # 11019510 - 1955-1957 CAR Staggered Shock Kit

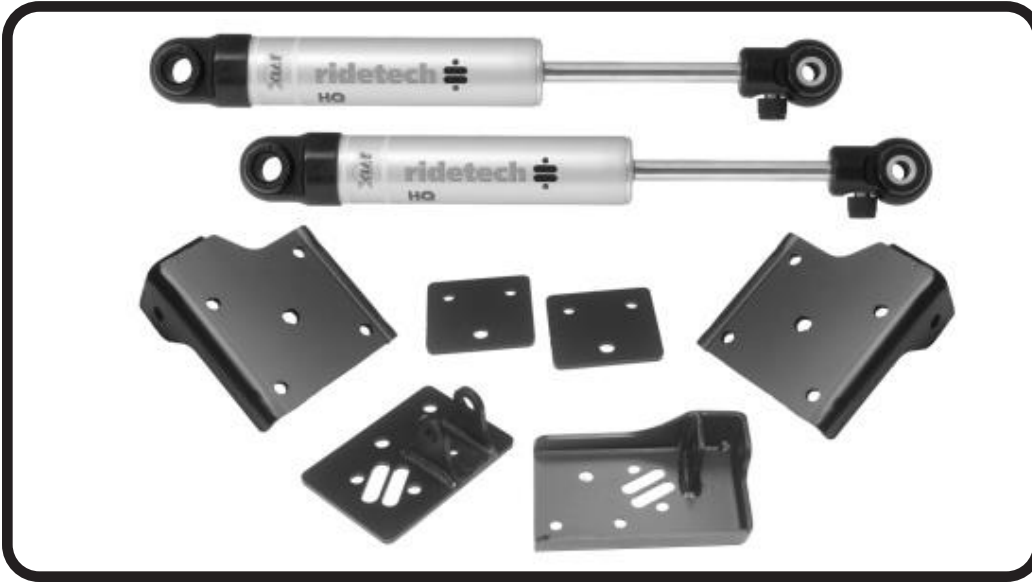

Recommended Tools

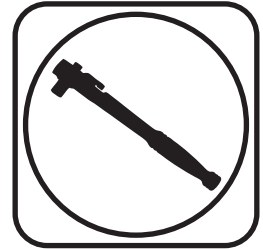

HQ Series Staggered Shock Kit Installation Instructions

Table of contents

Page 6.....	Components
Page 7.....	Getting Started and Lower Mount Installation
Page 8.....	Upper Mount Installation
Page 9.....	Shock Installation
Page 10.....	Shock Adjustment





7.55" HQ Series Smooth Body Shocks

Major ComponentsIn the box

Part #	Description	QTY
986-10-020-1	7.55" Stroke Shock	2
70011138	3/4" ID Shock Bushing (Installed in Shock)	4
90002013	5/8" ID Shock Sleeve (Installed in Shock)	2
90002102	1/2" ID Shock Sleeve (Installed in Shock)	2
90002553	Upper Shock Mount Assembly - Driver	1
90002552	Upper Shock Mount Assembly - Passenger	1
90002551	Upper Shock Mount Clamping Plates	2
90001617	Shock Stud	2
90002556	Leaf Spring U-Bolt Plates	2

HARDWARE

Part #	Description	Usage	QTY
99431008	7/16"-14 x 1 1/2" Hex Bolt	Upper Shock Mount to Body	2
99433002	7/16" Flatwasher	Upper Shock Mount to Body	4
99432001	7/16"-14 Nylok Nut	Upper Shock Mount to Body	2
99371004	3/8"-16 x 1 1/4" Hex Bolt	Upper Shock Mount to Body	4
99373003	3/8" Flatwasher	Upper Shock Mount to Body	8
99372002	3/8"-16 Nylok Nut	Upper Shock Mount to Body	4
99501003	1/2"-13 x 2 1/2" Hex Bolt	Shock to Upper Shock Mount	2
99503001	1/2" Flatwasher	Shock to Upper Shock Mount	4
99502001	1/2"-13 Nylok Nut	Shock to Upper Shock Mount	2
99436001	7/16"-20 U-Bolt	U-Bolt Plate	4
99432009	7/16"-20 High Nut	U-Bolt Plate	8
99433005	7/16" SAE Flatwasher	U-Bolt Plate	8

The Rear Shocks will be installed in conjunction with the Rear Leaf Springs.



Getting Started.....

THE RIDETECH COMPOSITE LEAF SPRINGS (11014799) & DELRIN LEAF SPRING BUSHING KIT (11015399) ARE RECOMMENDED TO ACHIEVE MAXIMUM PERFORMANCE.

THE STAGGERED SHOCK KIT IS DESIGNED TO BE INSTALLED IN CONJUNCTION WITH THE COMPOSITE LEAF SPRING KIT, #11014799.

1. Jack the car up and support it by the frame rails. You will need to raise and lower the rear differential with a jack to ease installation. With the car supported by the frame, put the jack underneath the rear end housing and raise the jack up just enough to support the differential. Disconnect the bottom of the shock and remove the lower clamping plate/shock mount.
2. Remove the shocks from the car.

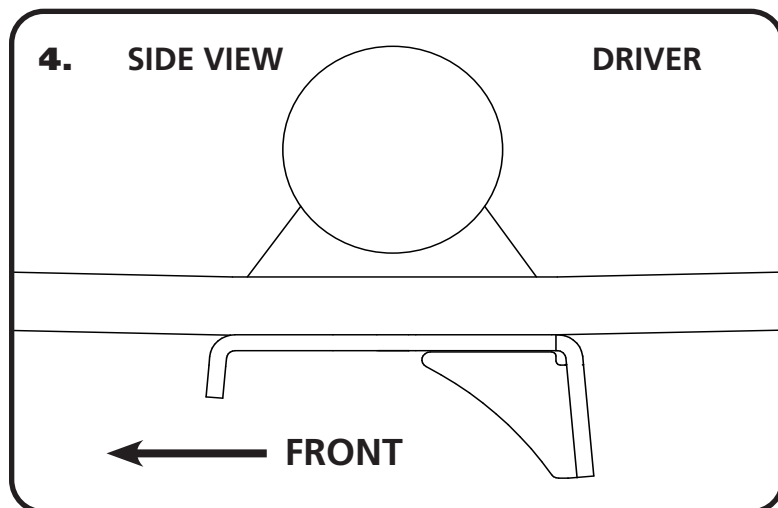
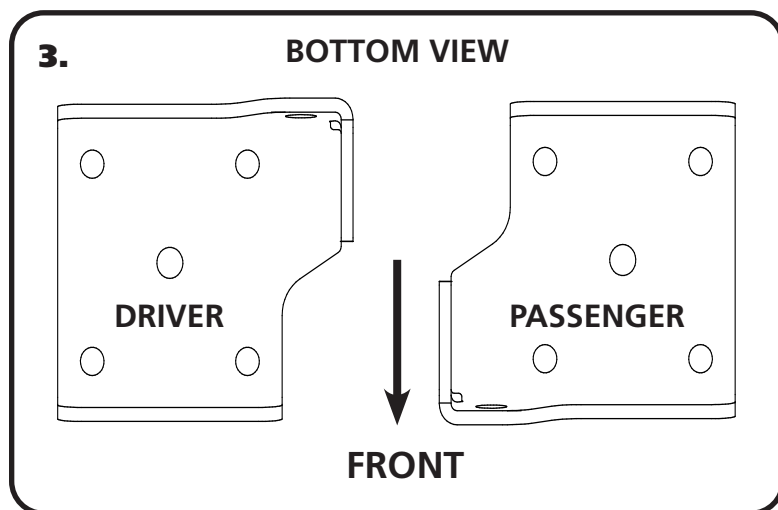

3. Diagram "3" shows the U-Bolt Plates/Shock Mounts as viewed from the bottom. Diagram "4" shows the Driver Mount viewed from the outside of the car. The Driver Mount positions the bottom of the shock to the inside behind the axle. The Passenger Mount positions the bottom of the shock to the inside in front of the axle. Install the 7/16" U-bolts on the axle tube in place of the OEM u-bolts. Slide the New U-Bolt Plates onto the U-bolts using Diagram "3" as a reference. Verify that the lower locating pin is indexed into the locating hole of the Plate. Install a 7/16" Flatwasher and 7/16-20 High Nut on each U-bolt. Evenly tighten the hardware by tightening in a crisscross fashion. Torque the nuts to 55 ftlbs.

Composite Leaf Spring Note: When tightening the mounts, pay attention to the pads on the springs to make sure there is visible compression of the pads. .030"- .060" of compression is needed for the springs to be securely mounted. All of the clamping force needs to be on the spring itself.



Upper Mount Installation



5. The Driver upper Shock Mount repositions the top of the shock. There are 3 holes in the bracket for mounting, (2) 7/16" & (1) 1/2". The 1/2" hole uses the OEM shock hole as a locator. Insert a 7/16"-14 x 1 1/2" bolt into the 1/2" hole. Position the mount with the 7/16" bolt inserted into the OEM shock hole. Align the inside edge of the mount with the body. Mark and drill the 2 remaining holes with a 3/8" drill bit.

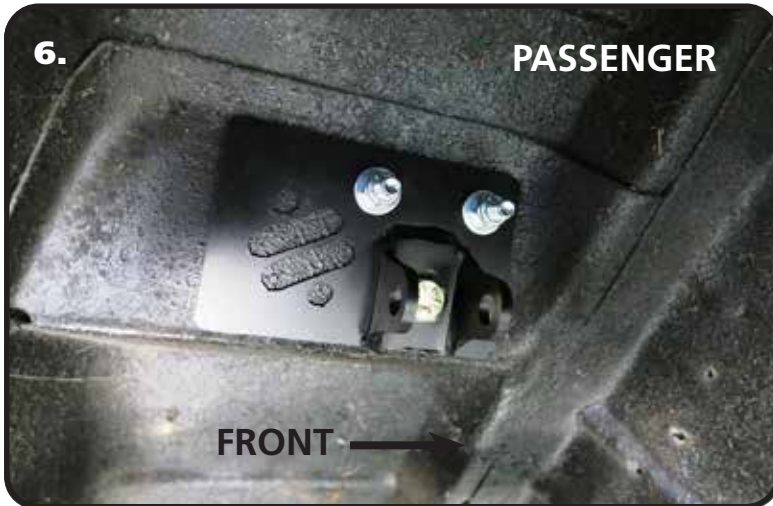

6. The Passenger upper Shock Mount keeps the shock in the OEM location, but converts the shock to an eyelet. There's 3 holes in the bracket for mounting, (2) 7/16" & (1) 1/2". The 1/2" hole uses the OEM shock hole as a locator. Insert a 7/16"-14 x 1 1/2" bolt into the 1/2" hole. Position the mount with the 7/16" bolt inserted into the OEM shock hole. Align the inside edge of the mount with the body. Mark and drill the 2 remaining holes with a 3/8" drill bit.



7. Position the Backer Plate on the top side of the OEM shock mount aligning the 1/2" hole with the OEM hole and the (2) 7/16" with the drilled holes. Install a 3/8" Flatwasher on each of (2) 3/8"-16 x 1 1/4" bolts and insert them through the backer plate into the drilled holes. The remaining bolt **MUST BE INSTALLED FROM THE BOTTOM**. Install the 7/16"-14 x 1 1/2" bolt through the Shock mount and slide it in place over the 3/8" bolts. Install a 3/8" Flatwasher and 3/8"-16 Nylok Nut on each 3/8" bolt and tighten. Install a 7/16" Flatwasher & 7/16"-14 Nylok Nut on the 7/16" bolt sticking through the backer. Repeat on both sides and tighten Hardware.



Shock Installation



8. The Shock is mounted in the Upper Mount with the BODY UP. It is held in place with a 1/2"-13 x 2 1/2" Hex Bolt & 1/2"-13 Nylok with a 1/2" Flatwasher on each side of the bracket.

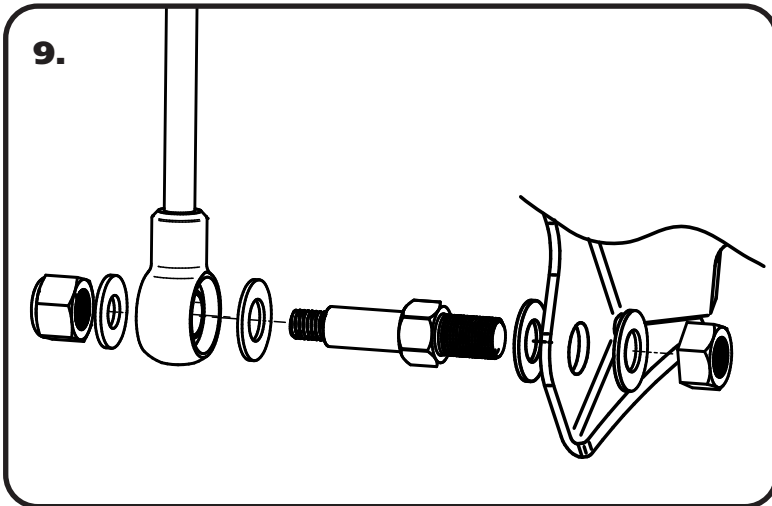

9. The Lower Shock is Bolted to the Lower Shock Mount using the supplied Shock Stud. Insert the Shock Stud into Lower Mount with a 5/8" Flat Washer on EACH side of the mount. Install a 5/8" Lock Nut on the threads and tighten. Next, slide a Washer on the Shock Stud. Jack the Rear Differential up until the Shocks can be slid onto the Shock Studs. Install a 7/16" Flat Washer and 7/16" Hex Nut onto the Threads and tighten.



Shock Adjustment

Shock adjustment 101- Single Adjustable

Rebound Adjustment:

How to adjust your new shocks

The rebound adjustment knob is located on the top of the shock absorber protruding from the eyelet or stud top. You must first begin at the ZERO setting, then set the shock to a street setting of 12 or handling setting of 8.

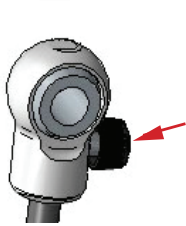

-Begin with the shocks adjusted to the ZERO rebound position (full stiff). Do this by rotating the rebound adjuster knob clockwise until it stops.

-Now turn the rebound adjuster knob counter clockwise 12 clicks. This sets the shock at 12 for a street setting. If you are after a handling setting only go 8 clicks.

Take the vehicle for a test drive.

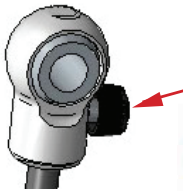

-if you are satisfied with the ride quality, do not do anything, you are set!

-if the vehicle is too soft increase the damping effect by rotating the rebound knob clockwise 3 additional clicks.

-If the vehicle is too stiff rotate the rebound adjustment knob counter clock wise 2 clicks and you are set!

Take the vehicle for another test drive and repeat the above steps until the ride quality is satisfactory.

Note:

One end of the vehicle will likely reach the desired setting before the other end. If this happens stop adjusting the satisfied end and keep adjusting the unsatisfied end until the overall ride quality is satisfactory.