



11020201 or 11030201

1955-1957 GM B-Body HQ CoilOver Kit

Recommended Tools

Front Components:

11013510	Front CoilOvers
11012899	Front Lower StrongArms
11013699	Front Upper StrongArms
11019100	Front Sway Bar

Rear Components:

11027199/11037199	Rear 4Link System
11026510	Rear CoilOver Instructions

Miscellaneous Components:

85000000	Spanner Wrench
----------	----------------

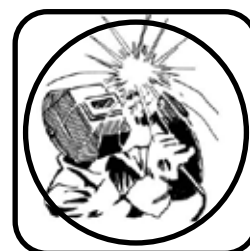
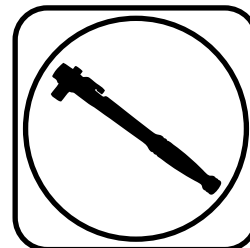

1955-1957 GM "B" Body CoilOver Installation Instructions

Table of contents

Pages	2-6.....	Front CoilOvers
Pages	7-11.....	Front Lower StrongArms
Pages	12-15.....	Front Upper StrongArms
Pages	16-20.....	Front Sway Bar
Pages	21-32.....	Rear 4-Link
Pages	33-34.....	Rear CoilOvers
Pages	35-36.....	CoilOver Assembly and Shock Adjustment





Part # 11013510 - 55-57 GM B-Body Front HQ Coil-Over for StrongArms

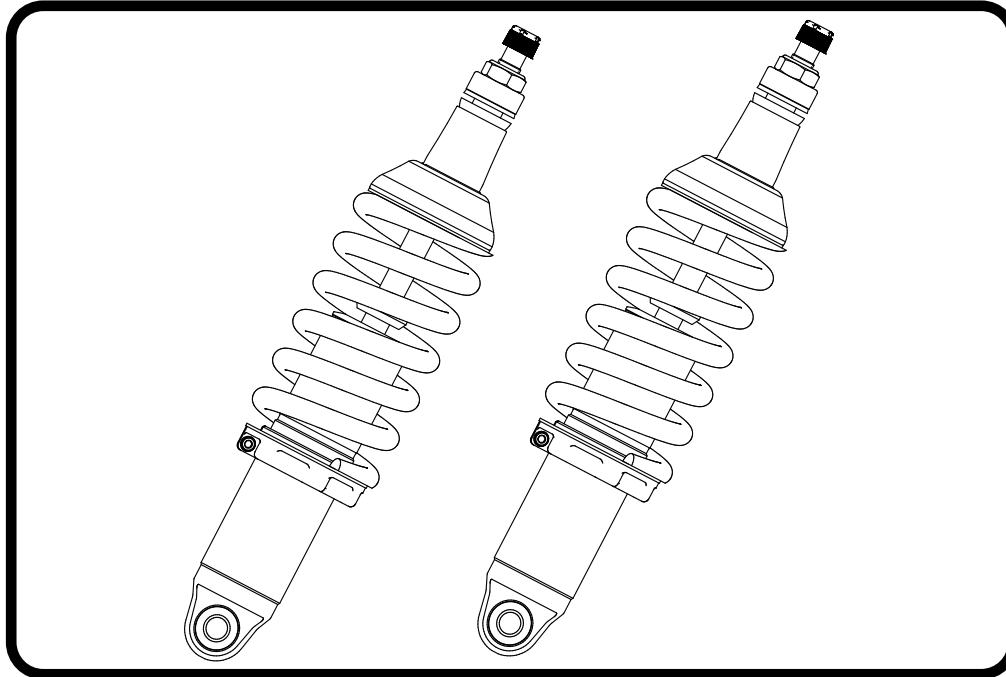

Recommended Tools

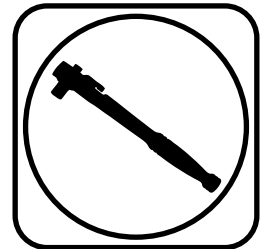

HQ Series CoilOver, 2.0" Stud/Bearing 4.1" Shock Installation Instructions

Table of contents

- Page 3..... Included Components
- Page 4..... CoilOver Assembly
- Page 5-6..... CoilOver Installation

CoilOver Dimensions:

Mount to Mount:

- Compressed: 10.43"
- Ride Height: 12.50"
- Extended: 14.53"

THE DELRIN BALL REQUIRES A 3/4" HOLE FOR THE FLANGE TO GO THROUGH. THIS CAN BE DRILLED WITH A UNIBIT.

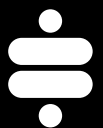



Major ComponentsIn the box

Item #	Part #	Description	QTY
1	982-10-804	4.1" Stroke HQ Series Shock	2
2	59100600	CoilSpring 10" 600lb	2
3	70010828	Delrin Spring Washer	4
4	234-15-200	Lower Spring Adjuster Nut	2
5	99050001	Adjuster Nut Locking Screw	2
6	90002070	Dropped Upper CoilSpring Retaining Plate	2
7	038-01-008-A	CoilSpring Plate Retaining Ring	2
8	90009988(kit)	2.00" Stud Adjuster Assembly	2
9	90002312	2.00" Stud Top Base	2
10	90001904	Delrin Ball Lower Half	2
11	90001903	Delrin Ball Top Half	2
12	90001902	Delrin Ball Upper Cap	2
13	99562003	9/16-18" Nylok Nut	2
14	210-35-120-0	Shock Adjuster Knob	2
15	90009969	Adjuster Knob Retaining Screw	2
	90001994	5/8" ID Bearing (installed in shock body)	2
	90001995	Bearing Snap Ring (installed in shock body)	4

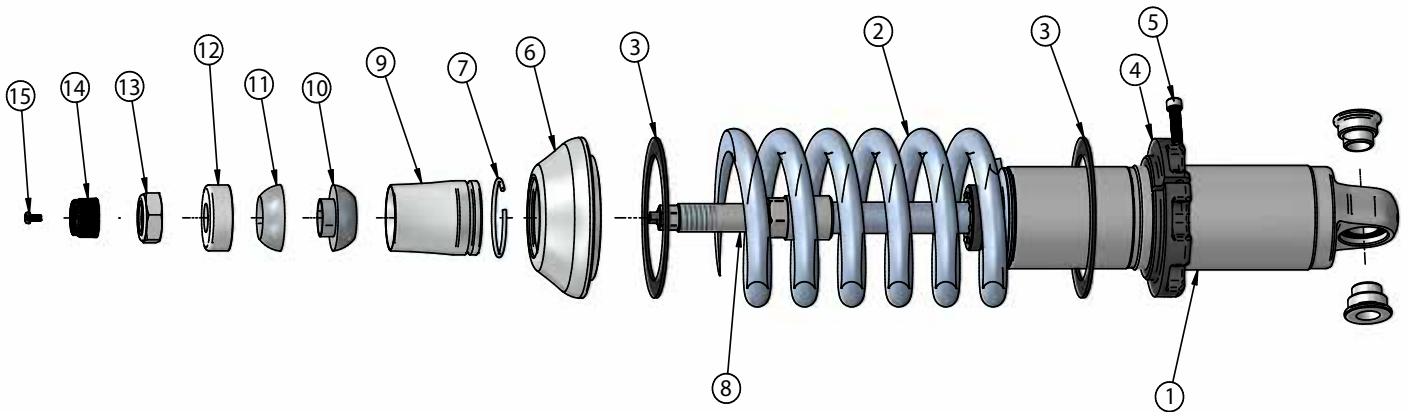



CoilOver Assembly

1.

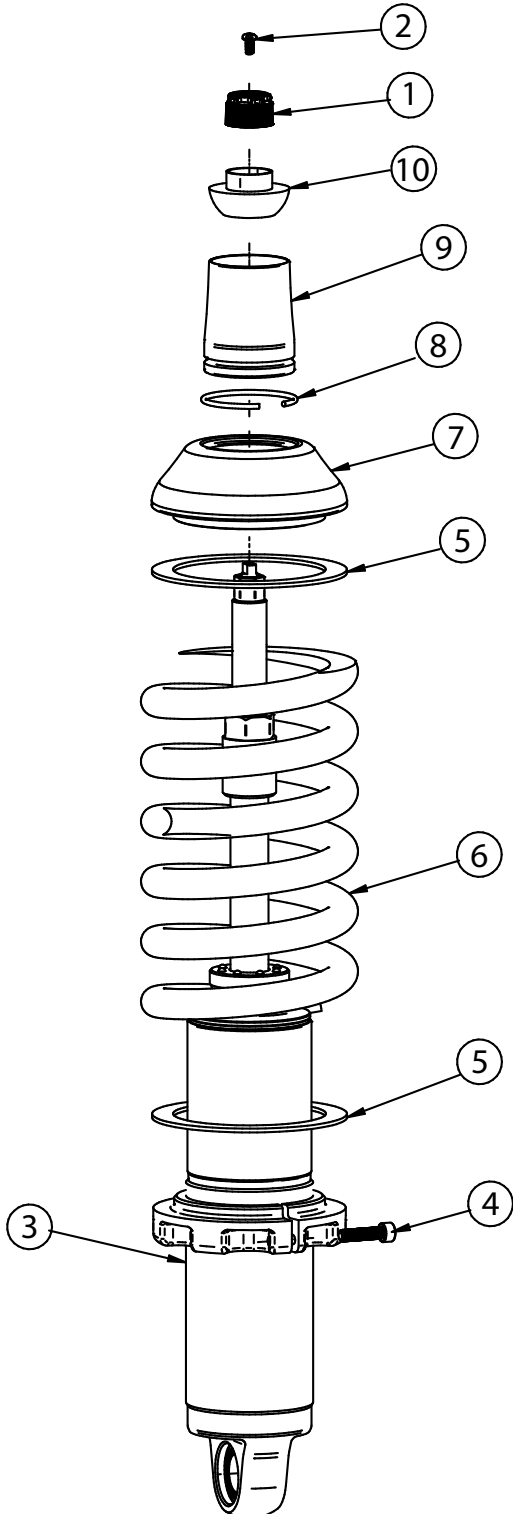

1. To Assemble the CoilOver you need to:
 - a. Remove Screw (2) from center of Adjustment Knob (1) and remove Adjustment Knob.
 - b. Remove Nylok Nut, Delrin Upper Cap, Delrin Upper and Lower Balls, along with the base from the Coliover stud.
 - c. Thread Adjuster Nut (3) onto the CoilOver body. Once it is threaded on the shock body, lightly thread in the locking screw (4) into the Adjuster Nut.
 - d. Install a Delrin Spring Washer (5) onto the Adjuster Nut.
 - e. Slide the CoilSpring (6) onto the CoilOver.
 - f. Install another Delrin Spring Washer (5) on top of the CoilSpring.
 - g. Install the Upper CoilSpring Plate (7) onto the CoilSpring.
 - h. Install the CoilSpring Retaining Ring (8) onto the Stud Top Base (9). It fits into the groove in the base.
 - i. Slide the Stud Top Base onto the shock until it bottoms out on the stud. It may be necessary to thread the Adjuster Nut down the shock body (to lower the spring) if the base will not slide all the way down onto the stud.
 - k. Slide the Lower Delrin Ball (10) (it has the collar sticking up around the center hole) on to the Stud Top.

Repeat on second CoilOver.



CoilOver Installation



2. Remove the OEM bushing flange by prying it out of the frame hole. After removing the flange, drill the OEM shock hole out to 3/4". This can be done with a Unibit.

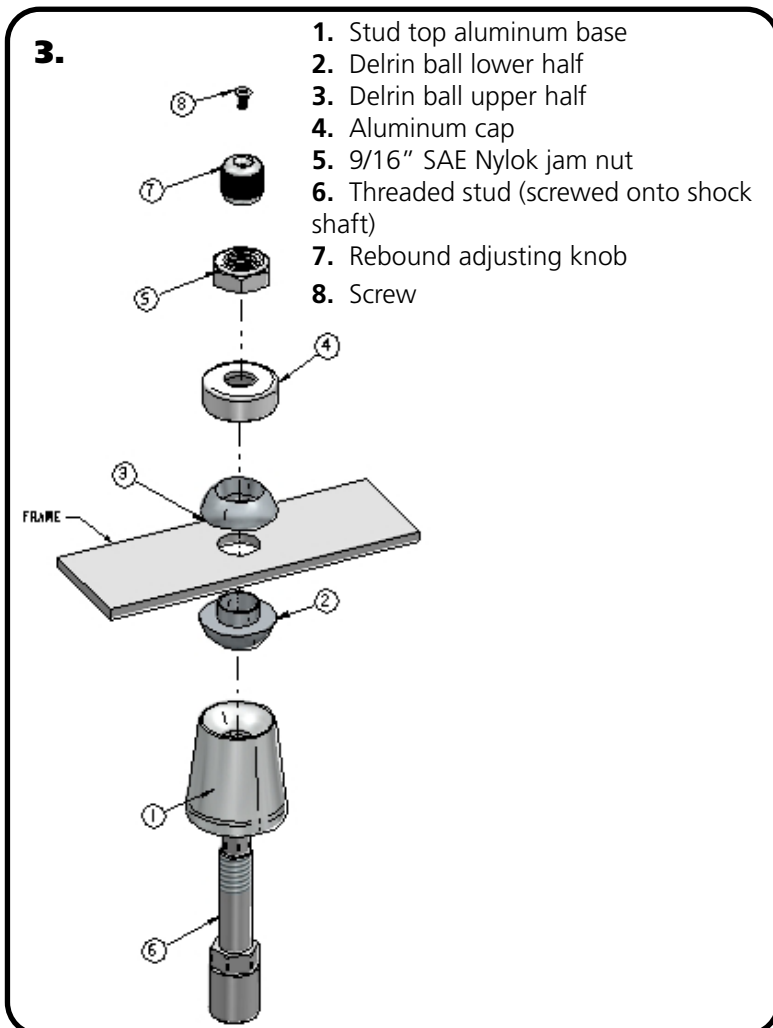

3. Place the CoilOver into the coil spring pocket with the stud sticking through the OEM shock hole. See assembly **Diagram 3**. OEM Shock hole **must** be drilled out to 3/4"

1. Stud top aluminum base
2. Delrin ball lower half
3. Delrin ball upper half
4. Aluminum cap
5. 9/16" SAE Nylok jam nut
6. Threaded stud (screwed onto shock shaft)
7. Rebound adjusting knob
8. Screw

TIGHTENING THE TOP 9/16"-18 NUT: SNUG THE NUT DOWN AGAINST THE TOP CAP. YOU NEED TO BE ABLE TO ARTICULATE THE SHOCK BY HAND. WE TORQUE THE NUT TO 80 INLBS USING A 7/8" CROWS FOOT WRENCH ON A TORQUE WRENCH.



CoilOver Installation

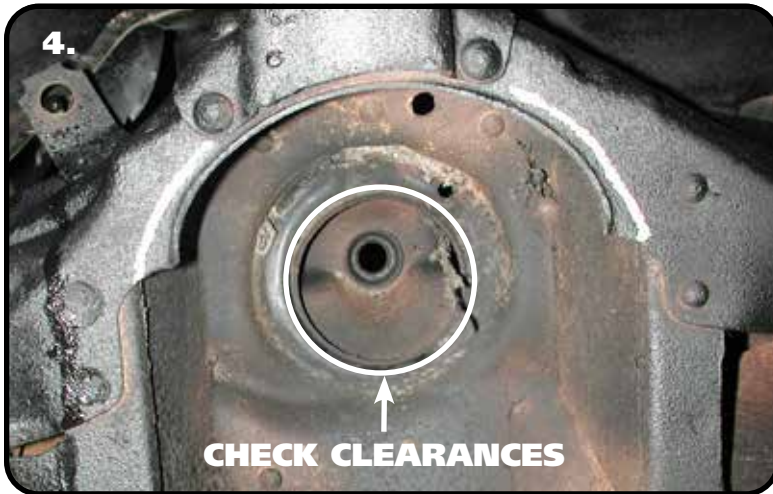

4. Mock the CoilOver up in the opening and check for clearances on the coil spring locating ring. Check clearance between the upper factory spring retaining lip and stud top base. Allowing this to hit could cause the shock to break, this

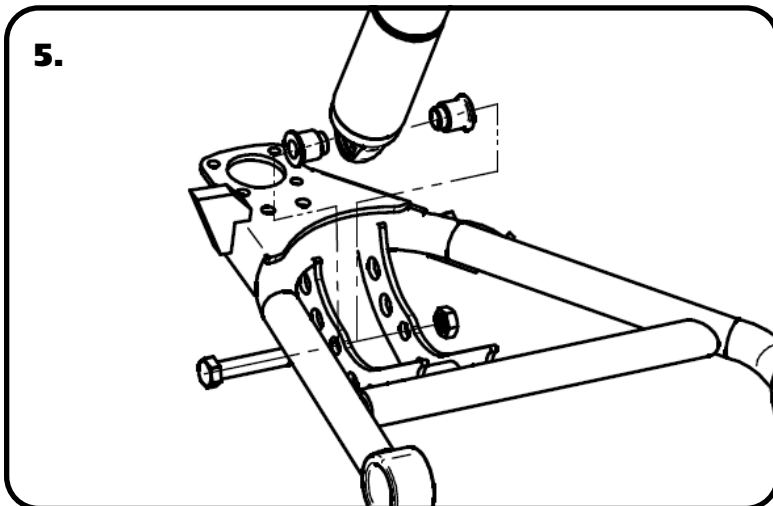

5. Install a spacer into each side of the lower Coilover bearing. Slide the shock with the spacers installed into the lower control arm. Raise the arm up to line up the holes in the bushing with the 1/2" hole in the control arm straps and hold it in place while you install the 1/2" x 3 1/2" bolt, 1/2" flat washer, and 1/2" Nylok nut. Torque the lower shock bolts to 75 ftbs.



Part # 11012899

1955-1957 GM B-Body Front Lower ShockWave/CoilOver StrongArms



Recommended Tools

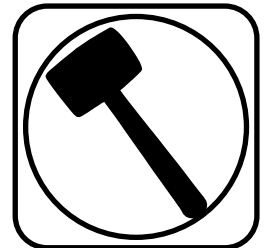
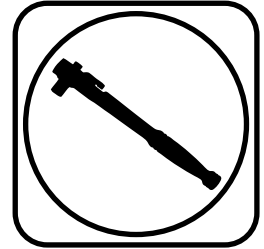

1955-1957 GM B-Body Lower StrongArms Installation Instructions

Table of contents

- Page 8..... Lower Control Arm Components
- Page 9..... Getting Started & Installation
- Page 10..... StrongArm Installation
- Page 11..... Installing Spindle and Alignment

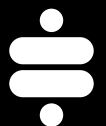



Upper Control Arm ComponentsIn the box

Item #	Part Number	Description	QTY
1	90001294	Driver Lower Control Arm (Shown)	1
1	90001295	Passenger Lower Control Arm	1
2	90000916 kit	Lower Ball Joint Kit - Proforged # 101-10080	2
3	90001442	Delrin Bushing	4
4	90001289	Delrin Bushing Inner Sleeve	4
5	90002694	Lower Cross Shaft Kit	1 pr
6	99433001	Outer Washer - Cross Shaft	4
7	90002062	Shock Bearing Spacers	4
8	99501005	1/2"-13 x 3 1/2" Hex Bolt GR8	2
9	99503014	1/2" SAE Flat Washer	4
10	99502009	1/2"-13 Nylok Nut	2
11	99313001	5/16" SAE Flat Washer GR8	8

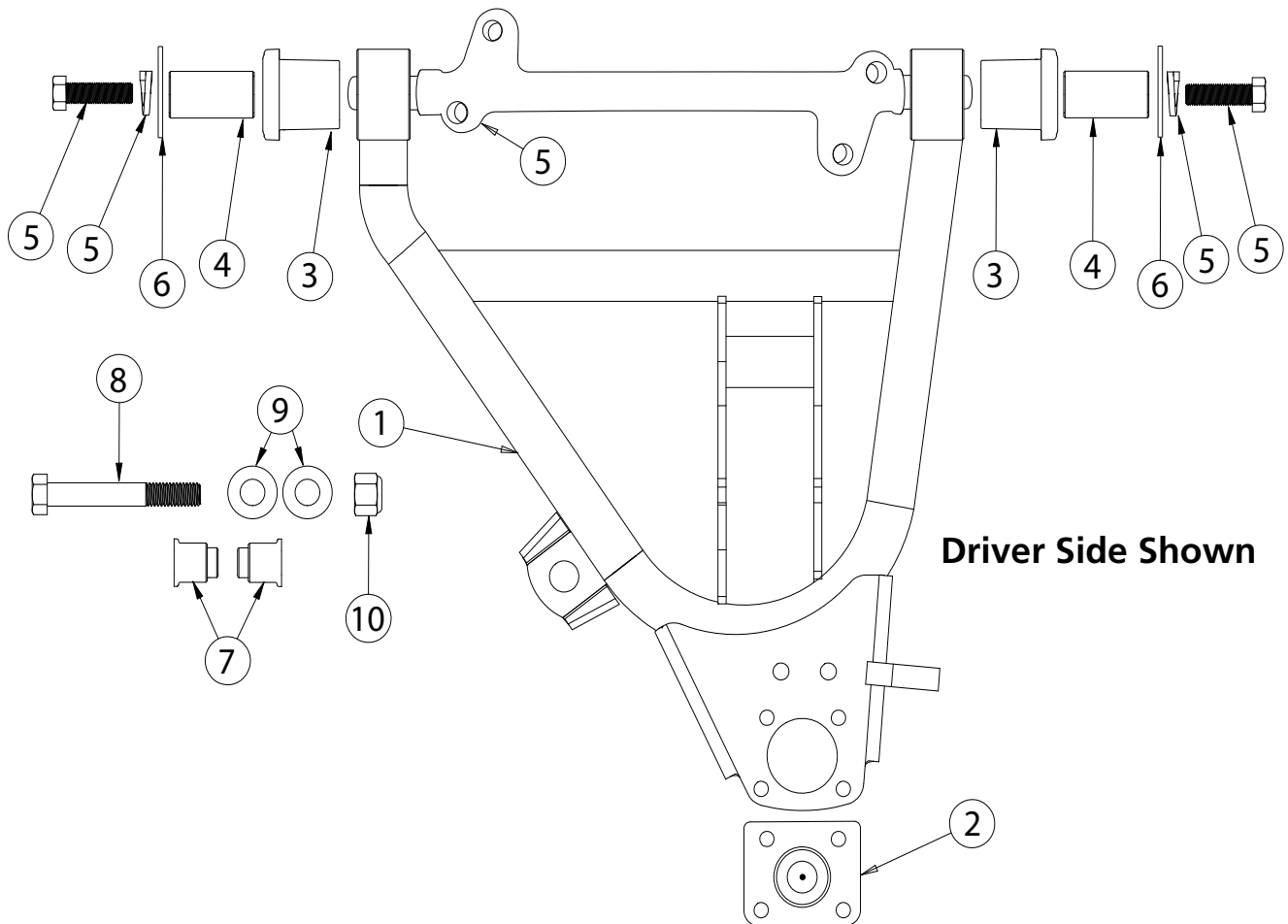



Getting Started.....

Congratulations on your purchase of the Ridetech Tri5 StrongArms. These StrongArms have been designed to give your Tri5 excellent handling along with a lifetime of enjoyment. Some of the key features of the StrongArms: Ball joint angles have been optimized for the lowered ride height, Delrin bushings are used to eliminate bushing deflection along with providing free suspension movement through the entire travel. The Delrin bushings are made from a material that is self lubricating so no grease zerks are needed.

When assembling the Control Arms, tighten the cross shaft bolts enough to create drag on the delrin bushings, the arm should still move through its travel by hand.

Installation

1. Remove the lower control arms from the car. If you are replacing the upper control arms and spindle, remove them too. Refer to a Factory Service Manual for the proper method.

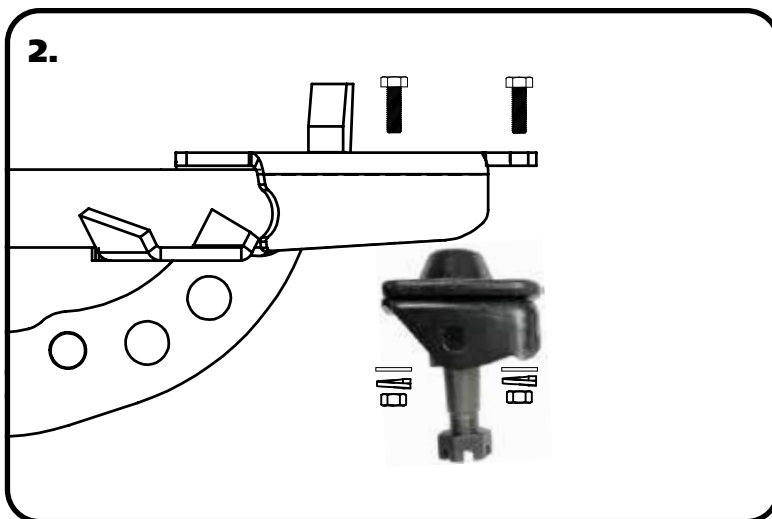

2. Insert the Ball Joint into the Control Arm from the bottom side with the Stud pointing downward. Insert the supplied Bolts from the top side. Install a 5/16" Flat Washer, Lock Washer and Hex Nut on the threads of each bolt. Torque the hardware to 20 ftlbs.

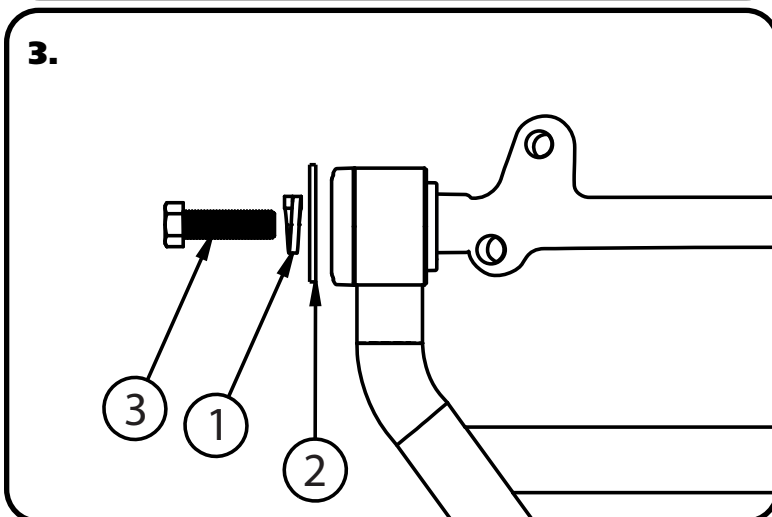

3. Install the supplied 7/16" Lock Washers & 7/16" Flat Washers on each of the (4) 7/16"-20 x 1 1/2" Bolts supplied in the kit. Thread each Bolt/Washer setup into the end of the Cross Shaft of the Lower Control Arm. Do not tighten until the control arms are installed on the car. Torque the hardware 45-55 ft-lbs.



Installing StrongArm

4.

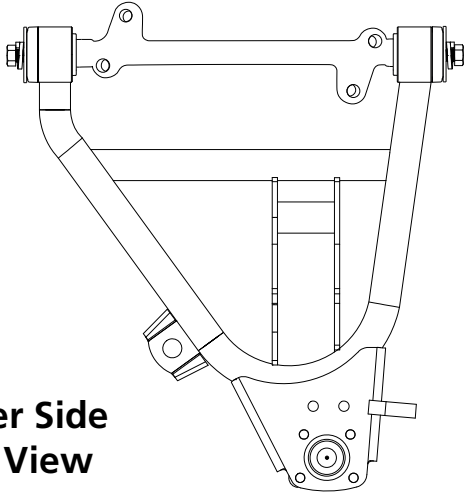

Driver Side
Top View

4. The Lower Control Arm is attaching the frame using factory hardware. The driver side arm is shown in **Figure "2"**. The sway bar mount is located to the front of the car.

Install the ShockWaves/CoilOvers at this time. Refer to the ShockWaves/CoilOvers instructions for Assembly.

5.



5. The Lower Control Arm is attaching the frame using factory hardware. The driver side arm is shown in **Figure "3"**. Torque the hardware 65-75 ft-lbs.

6.

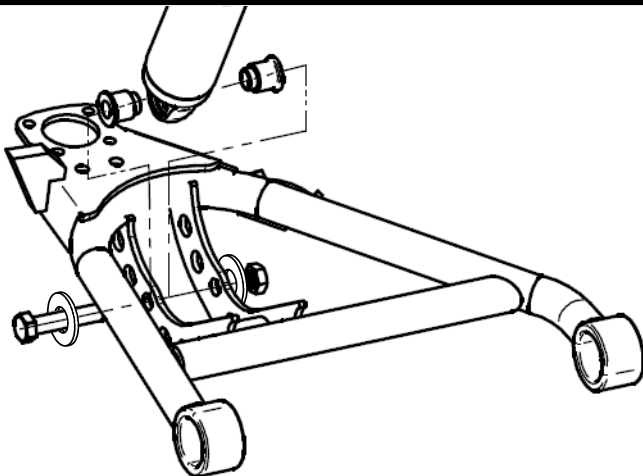

6. Bolt the Shockwave or CoilOver to the lower arm using the supplied 1/2" x 3 1/2" bolt, 1/2" flat washers, and 1/2" nylok nut. Insert the supplied aluminum spacers in each side of the shock bearing and slip it into the control arm. Line the spacers/bearing up with the 1/2" hole in the shock straps of the control arm and install hardware. Torque the hardware to 75 ftlbs.



Installing Spindle and Alignment



7. Attach the Spindle to the control arms.

Torque Specs:

Ball joint - 45 ftlbs and tighten to line up cotter pin.

Install the Cotter Pin after tightening the ball joint nut.

INSTALL THE GREASE ZERK IN THE BALL JOINT AND GREASE THE BALL JOINT AFTER ASSEMBLY.

8. Tighten all fasteners. Connect the sway bar linkage to the new StrongArms. If you are going to install the Ridetech MuscleBar, now is a good time to do it.

When assembling the Control Arms, tighten the cross shaft bolts enough to create drag on the delrin bushings, the arm should still move through its travel by hand.

Suggested Alignment Specs:

Camber: Street: -.5 degrees
Caster: Street: +3.0 to + 5.0 degrees
Toe: Street: 1/16" to 1/8" toe in



Part # 11013699 - 1955-1957 GM B-Body Front Upper StrongArms



Recommended Tools

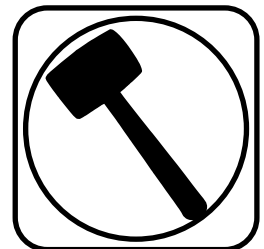
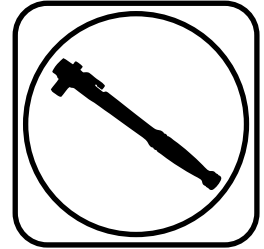

1955-1957 GM B-Body Upper StrongArms Installation Instructions

Table of contents

- Page 13..... Upper Control Arm Components
- Page 14..... Getting Started & Installation
- Page 15..... Installing Spindle and Alignment



Upper Control Arm ComponentsIn the box

Item #	Part Number	Description	QTY
1	90001292	Driver Upper Control Arm (Shown)	1
1	90001293	Passenger Upper Control Arm	1
2	90003041 kit	Tall Upper Ball Joint Kit - Proforged # 101-10477	2
3	90002695 kit	Cross Shaft Kit - contains 2 cross shafts	1
4	90001442	Delrin Bushing	4
5	90001288	Delrin Bushing Inner Sleeve	4
6	99373001	Outer Washer - Cross Shaft	4
7	99373005	3/8" Split Lock Washer -Cross Shaft	4
8	99371015	3/8"-24 x 1 1/2" Hex Bolt - Cross Shaft	4

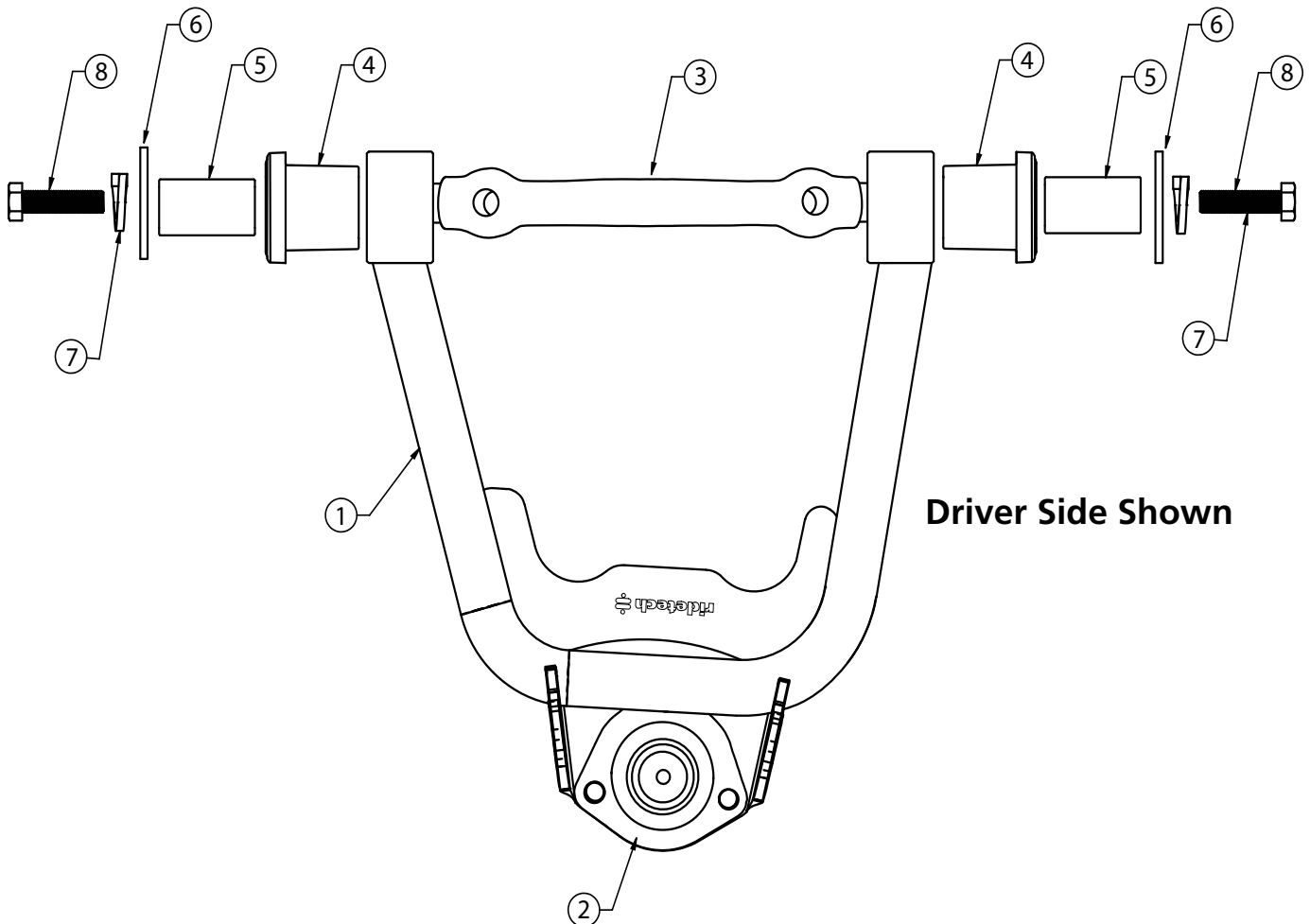



Getting Started.....

Congratulations on your purchase of the Ridetech Tri5 StrongArms. These StrongArms have been designed to give your Tri5 excellent handling along with a lifetime of enjoyment. Some of the key features of the StrongArms: Ball joint angles have been optimized for the lowered ride height, Delrin bushings are used to eliminate bushing deflection along with providing free suspension movement through the entire travel. The Delrin bushings are made from a material that is self lubricating so no grease zerks are needed.

When assembling the Control Arms tighten the cross shaft bolts enough to create drag on the delrin bushings, the arm should still move through its travel by hand.

Installation

1. Remove the upper control arms from the car. Keep the shims separate so that you can put them back in the location they were removed from. If you are replacing the lower control arms and spindle, remove them too. Refer to a Factory Service Manual for the proper method.

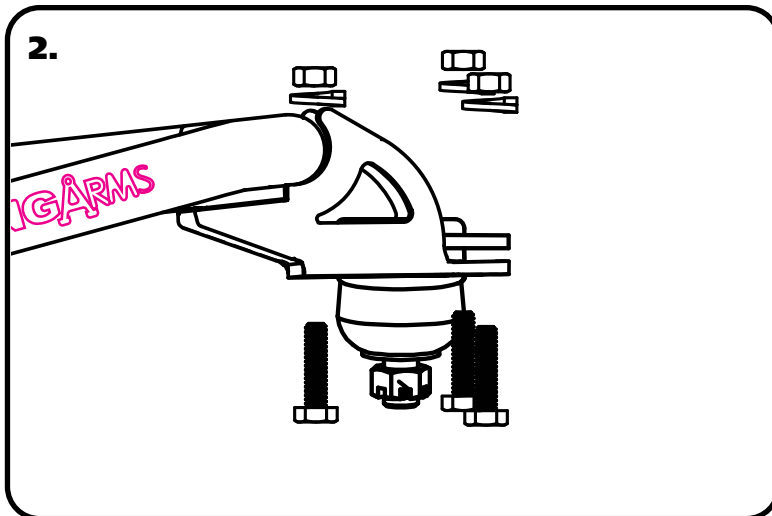

2. Insert the Ball Joint into the Control Arm from the TOP side with the Stud pointing downward. Insert the supplied Bolts from the bottom side. Install a Lock Washer and Hex Nut on the threads of each bolt. Torque the hardware to 18 ftlbs.

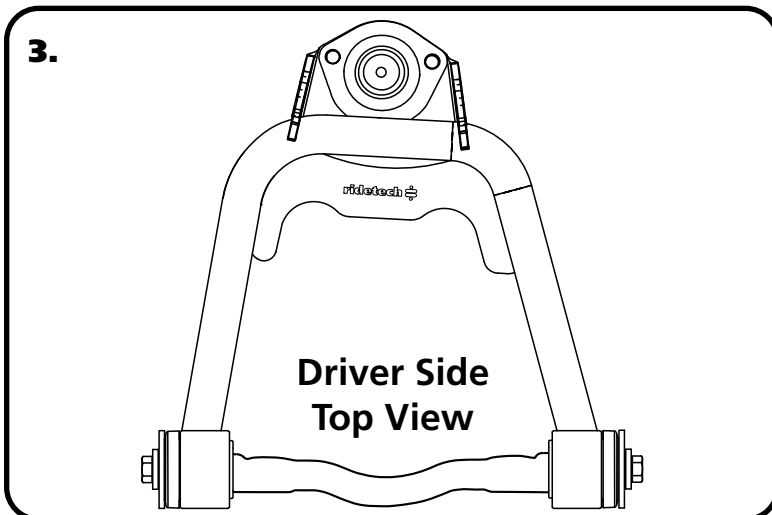

3. The Upper Control Arm is attached to the factory frame using factory hardware. The driver side arm is shown in **Figure "3"**. The Ball joint is located on the arm to the REAR of the car.



Installing Spindle and Alignment



4. The Upper Control Arm is attached to the factory mount using factory hardware. Reinstall the shims in the location they were removed from. The passenger side arm is shown in **Figure "4"**. Torque the hardware 65-75 ft-lbs.



5. Attach the Spindle to the control arms.

NOTE: DUE TO THE LONGER SHANK OF THE BALL JOINT, THE BALL JOINT BOOT IS DESIGNED TO SEAL ON THE BALL JOINT SHANK. IT DOES NOT SEAL AGAINST THE SPINDLE. A SEGMENT OF EXPOSED BALL JOINT STEM IS NORMAL.

Torque Specs:

Ball joint - 45 ftlbs and tighten to line up cotter pin.

Install the Cotter Pin after tightening the ball joint nut.

6. Tighten all fasteners.

When assembling the Control Arms tighten the cross shaft bolts enough to create drag on the delrin bushings, the arm should still move through its travel by hand.

Suggested Alignment Specs:

Camber: Street: -.5 degrees
Caster: Street: +3.0 to + 5.0 degrees
Toe: Street: 1/16" to 1/8" toe in



Part # 11019100 - 1955-1957 B-Body Front Sway Bar

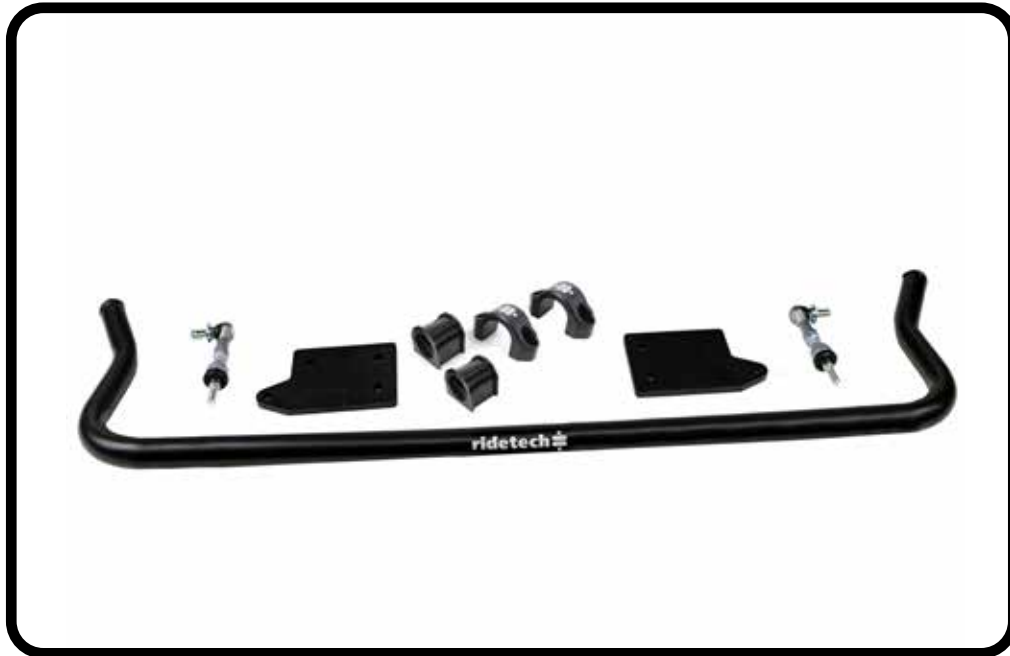

Recommended Tools

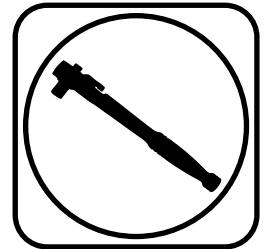

1955-1957 GM B-Body Front Sway Bar Installation Instructions

Table of contents	
Page 17.....	Included Components and Hardware List
Page 18.....	Sway Bar Installation
Page 19.....	Frame Mount Installation
Page 20.....	Frame Mount and PosiLink Installation

Install all Front Suspension Components before installing the Sway Bar.



Major ComponentsIn the box

Item #	Part #	Description	QTY
1	90000731	Front Sway Bar	1
2	90001343	Billet Sway Bar Bushng Strap	2
3	70015014	Line Sway Bar Bushing	2
4	90000729	Sway Bar Bushing Frame Plate	2
5	90000717	Aluminum Step Washer - Control Arm	4
6	90000924	10mm Straight PosiLink - PosiLink Assembly	2
7	90000926	10mm 90 Degree PosiLink - PosiLink Assembly	2
	99115001	10mm x 1.5" Thread Stud - PosiLink Assembly	2



Hardware Kit99010047

Part #	Description	Usage	QTY
99371005	3/8" -16 x 1 1/4" Hex Bolt	Bushing Mount & Bushing to Frame	8
99373003	3/8" Flat washer	End link & Bushing Mounts	18
99372002	3/8" -16 Nylok Nut	End link & Bushing Mounts	8
99115006	M10 Lock Washer	PosiLink to Sway Bar	2
99112002	M10-1.5 Nylok Nut	PosiLink to Control Arm	2

Getting Started.....

Install all front suspension components before installing the sway bar.

The Tri5 didn't come equipped with a swaybar. This kit contains the mounts needed to add a swaybar to your Tri5. If your car already has a swaybar, it will need to be removed.

This sway bar kit utilizes a anti-friction lining in the sway bar bushing. The lining allows the sway bar to move freely and quietly in the bushing. No lubrication is required.



Sway Bar Installation



1. Open the sway bar bushing at the split and install the bushing over the sway bar. Install bushing straps over the sway bar bushings.

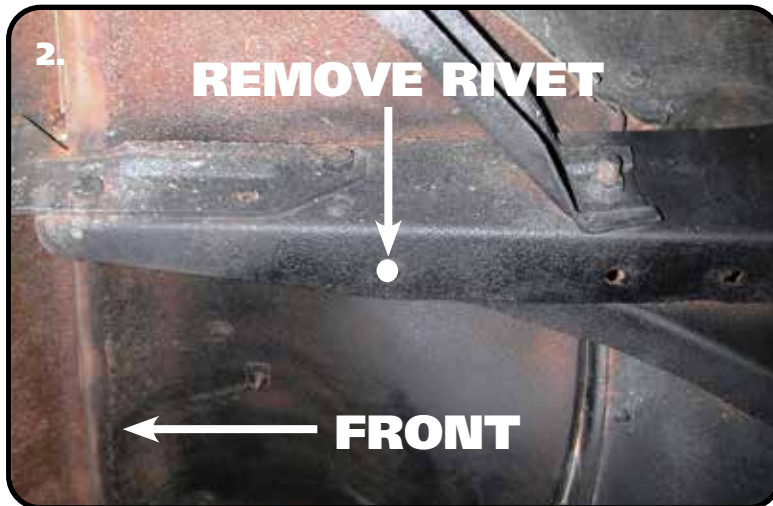

1955-1956 FRAME MOUNT INSTALLATION

2. The rivet shown in **Diagram "3"** will need to be removed. This hole will be used to locate the sway bar frame mount.

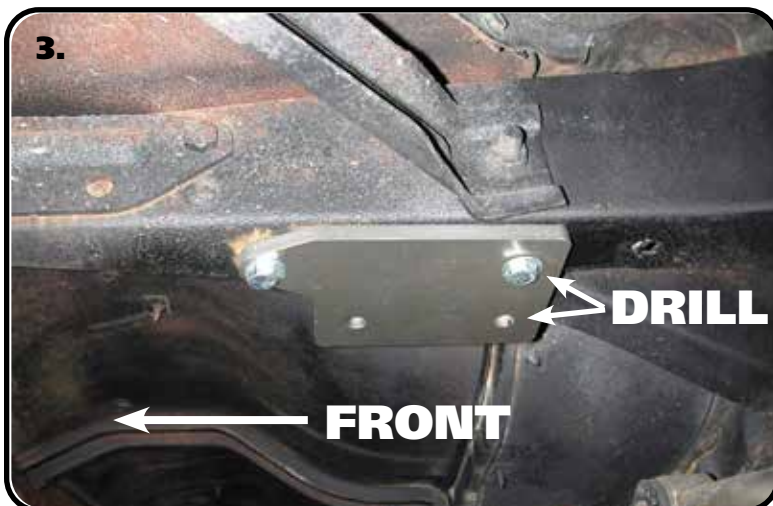

3. **Diagram "3"** shows the mounting plate installed on the driver side. Use a 3/8" flat washer on a 3/8"x 1 1/4" hex bolt to attach the frame plate to the frame. Insert the bolt into the rivet hole with the plate positioned as it is in **Diagram "4"**. With the bolt inserted into the rivet hole, use a 3/8" flat washer and 3/8" nylok nut to snug it down. Align the mounting plate parallel with the outside of the frame rail and drill the rear 2 holes through the frame. Insert a second 3/8" hex bolt and 3/8" flat washer into the rear hole with a 3/8" Flat washer and 3/8" nylok nut to tighten. Repeat process on other side and tighten hardware. The rear inner hole will be used later.



Frame Mount Installation



4. Install 3/8" flat washers on (2) 3/8" x 1 1/4" hex bolts. Install them through the top side of the of the remaining holes in each mounting plate with the threads pointing down. The rear bolt will also go through the frame rail.



5. With the bushings and straps installed on the sway bar, put the swaybar in position on the 3/8" bolts. Attach it using 3/8" flat washers and 3/8" nylok nuts. Do **NOT** completely tighten the hardware. It will be left partially loose until the PosiLinks are installed.



1957 FRAME MOUNT INSTALLATION

6. There isn't a rivet to use as a locator on the 1957 frame. The frame mount is position 5" from the FRONT of the frame rail to the FRONT EDGE of the frame mount. The center of the bolt hole is 1 1/2" from the outside edge of the frame. Use the frame mount as a template to drill the 2 holes. The hardware will need to be installed from the top with the threads pointing down. Use a 3/8" x 1 1/4" hex bolt with a flat washer in each one. Do this for both sides. With the hardware installed, install a frame mount on the hardware with the SMALL bolt pattern to the inside of the car. Tighten down with a 3/8" flat washer and 3/8" nylok nut



Frame Mount & End Link Installation



7. Install 3/8" flat washers on (2) 3/8" x 1 1/4" hex bolts and install them through the top side of the of the remaining holes in each mounting plate with the threads pointing down. With the bushings and straps installed on the sway bar, put the sway bar in position on the 3/8" bolts. Attach it using 3/8" flat washers and 3/8" nylok nuts. Do **NOT** completely tighten the hardware. It will be left partially loose until the PosiLinks are installed.



8. Bolt the 90 degree end of the PosiLink to the sway bar. A 3/8" flat washer and 10mm lock washer must be installed between the PosiLink and the bar.



9. Bolt the straight end of the PosiLink to the lower control arm. An aluminum step washer must be installed on each side of the control arm tab. Fasten with a 10mm Nylok nut and torque to 37 ft-lbs. Then tighten the bushing frame bolts to 30 ft-lbs.



11027199 or 11037199

1955-1957 GM "B" Body Rear R-Joint Bolt-in 4 Link

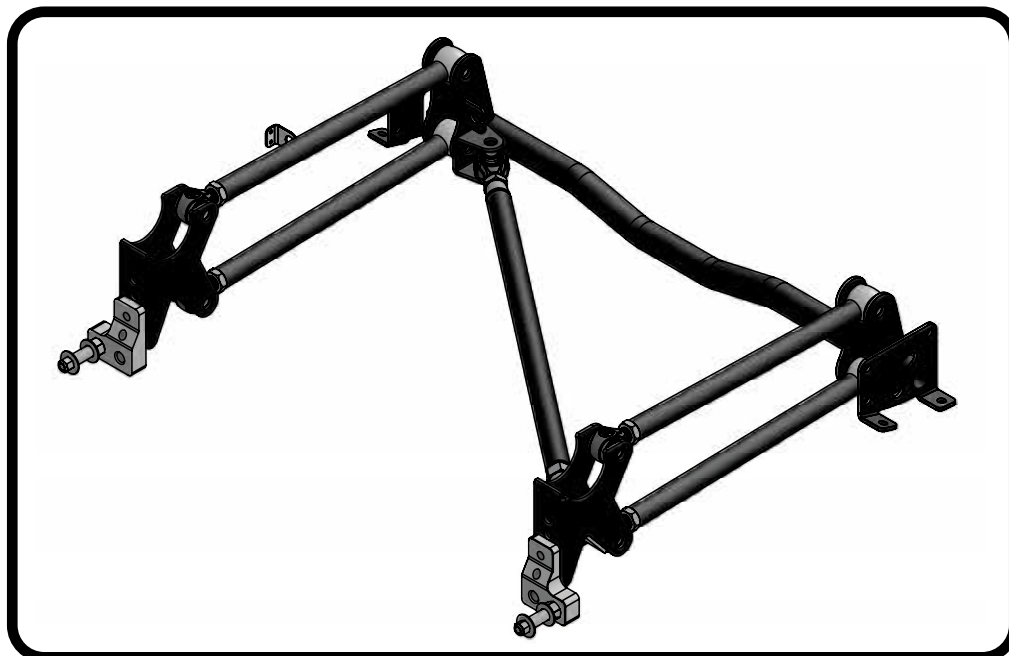

Recommended Tools

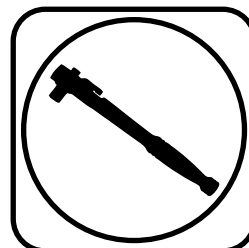
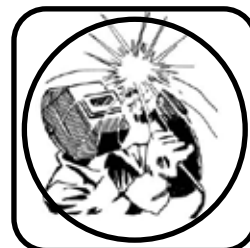

1955-1957 GM "B" Body Rear Bolt-in 4-Link Installation Instructions

Table of contents

Page 2-3.....	Included Components
Page 4.....	Hardware List & Getting Started
Page 5.....	Frame Variations
Page 5-6.....	Cradle Installation
Page 7.....	Upper Shock Mount Installation
Page 7.....	Axle Positioning
Page 8.....	Setting Pinion Angle
Page 9.....	Emergency Brake Cable Installation
Page 9.....	Bar Installation
Page 10.....	Installing Diagonal Bar & Attaching Axle Mounts
Page 11.....	Installing Lower Shock Mounts
Page 11-12..	Installing ShockWaves/CoilOvers





Major ComponentsIn the box

Item #	Part #	Description	QTY
1	90000556 or 90000557	One Piece Frame Front Cross Member (33.688") or Two Piece Frame Front Cross Member (35.125")	1 or 1
2	90000160	Lower Axle Bracket - Driver	1
3	90000558	Lower Axle Bracket w/Diagonal Bracket - Passenger	1
4	90000554	Upper Shock Mount - Driver	1
5	90000555	Upper Shock Mont - Passenger	1
6	90000550	Lower Shock Mount - Driver	1
7	90000551	Lower Shock Mount - Passenger	1
8	70002825	Lower Shock Stud	2
9	90000266	Brake Line Tab	1
10	90001432	Parallel Bars - 18.500" center to center	4
11	90002853	Diagonal Bar - 30.250" center to center	1
12	70013334	R-Joint Spacers	20
	90002067	Lower Shock Spacers	4
R-Joint Components - (Installed in bar ends)			
	70013279	Retaining Ring	4
	70013280	Wavo Wave Spring	4
	70013275	R-Joint Center Ball	4
	70013276	R-Joint Composite Center Ball Cage	4
	90001318	RH R-Joint Threaded Housing End (installed in bars)	5
	90001319	LH R-Joint Threaded Housing End (installed in bars)	1
	99752004	RH 3/4"-16 Jam Nut (installed on bar ends)	5
	99752006	LH 3/4"-16 Jam Nut (installed on bar ends)	1

New R-Joints will be quite stiff (75-90 in/lbs breakaway torque) until they "break in" after a few miles of use. After the break in period they will move much more freely. Because the composite bearing race contains self lubricating ingredients, no additional lubrication is needed or desired. Any additional lubrication will only serve to attract more dirt and debris to the R-Joint and actually shorten its life.



Major ComponentsIn the box

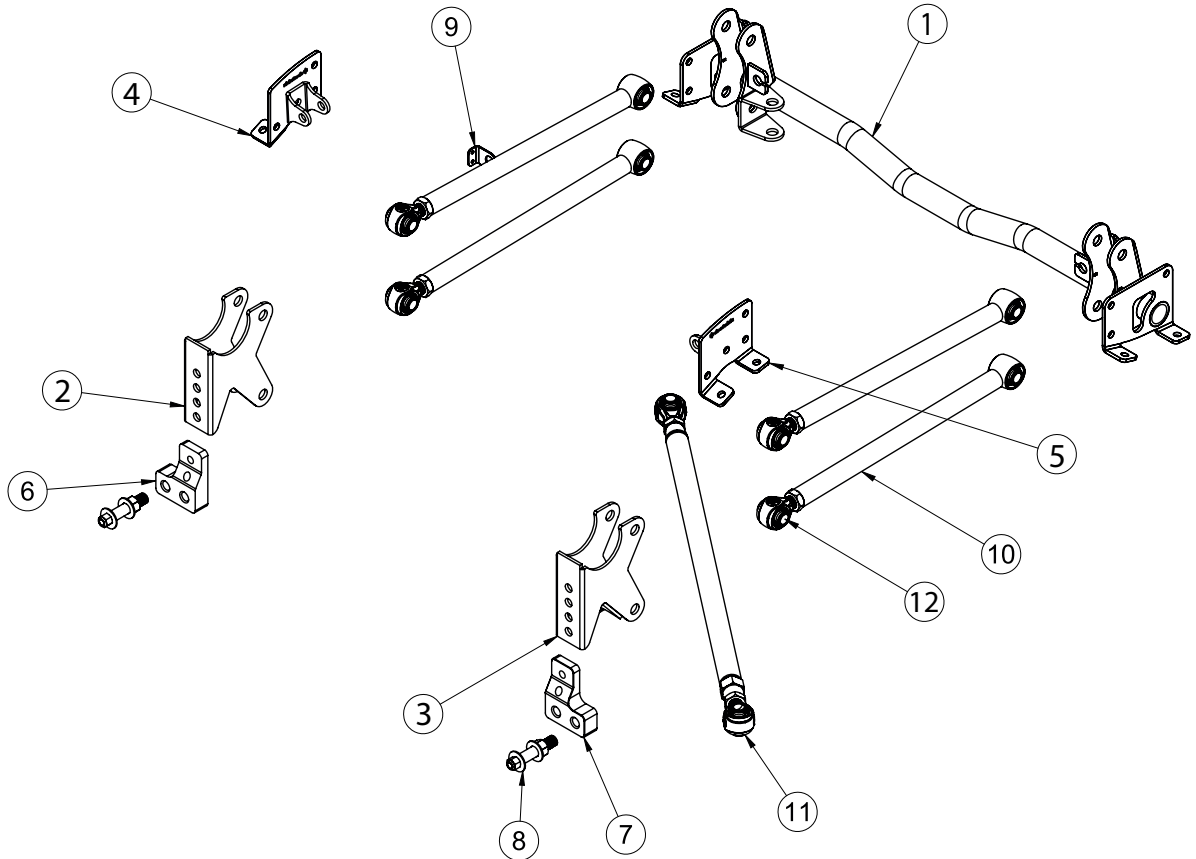

R-JOINT SPACER INSTALLATION

Install the Spacers by inserting the SMALL side of the SPACER into the Center Pivot Ball. Push them in until they bottom out and stop.

ALL R-JOINTS

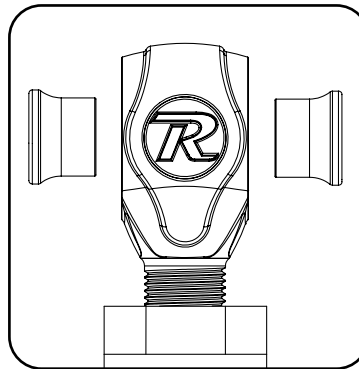

New R-Joints will be quite stiff (75-90 in/lbs breakaway torque) until they "break in" after a few miles of use. After the break in period they will move much more freely. Because the composite bearing race contains self lubricating ingredients, no additional lubrication is needed or desired. Any additional lubrication will only serve to attract more dirt and debris to the R-Joint and actually shorten its life.



Hardware ListIn the box (Kit# 99010019)

The Hardware Kit contains bags to help aid in selecting the correct hardware for the component being installed. The hardware list shows how the hardware is bagged.

QTY	Part Number	Description	QTY	Part Number	Description
FRONT CROSS MEMBER MOUNTING			UPPER SHOCK MOUNTING		
10	99373007	3/8"-16 x 1" Thread Forming	10	99373007	3/8"-16 x 1" Thread Forming
10	99373005	3/8" Lock Washer	10	99373005	3/8" Lock Washer
4 LINK BARS			2	99501026	1/2"-13 X 2 1/4" Hex Bolt
8	99621020	5/8"-11 X 2 3/4" Hex Bolt	2	99502007	1/2"-13 Nylok Jam Nut
2	99621017	5/8"-11 x 3" Hex Bolt	SHOCK STUD		
10	99622008	5/8"-11 Nylok Jam Nut	2	99432002	7/16"-20 Nylok Nut
LOWER SHOCK MOUNT			2	99433002	7/16" SAE Flat Washer
4	99501020	1/2"-20 X 3/4" Hex Bolt	2	99623004	5/8" SAE Flat Washer
BRAKE LINE BRACKET					
2	99101009	#10 x 3/4" Tek Screw			

Getting Started.....

Congratulations on your purchase of the Ridetech Rear 4-link System. This system has been designed to give your Tri-5 excellent handling along with a lifetime of enjoyment. This kit replaces the Leaf Springs, this allows the 4-Link to locate the rearend and the CoilOvers/ShockWaves to support the car. This allows each to be optimized for the best performance.

Note: These system is designed for use with the Ridetech Shockwaves or CoilOvers and the MuscleBar swaybar. **The factory shocks and springs will not fit this setup.**

This kit requires welding of the axle mounts to the differential. The front cross member and shocks mounts can also be welded in if you prefer.

1. Raise the vehicle to a safe and comfortable working height. Use jack stands to support the vehicle with the suspension hanging freely. You will need a method of raising and lowering the differential.
2. Support the axle and remove the leaf springs, shocks, bump stops, pinion snubber and tail pipes. Refer to the factory service manual for proper disassembly procedures.



Frame Rail Variations

1 Piece Frame - Kit 11027199



2 Piece Frame - Kit 11037199



1 Piece Frame Crossmember

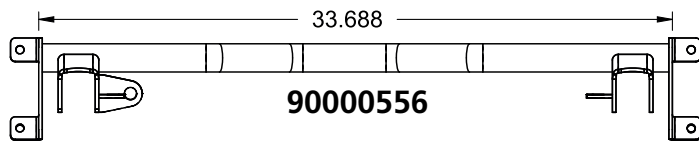

2 Piece Frame Crossmember

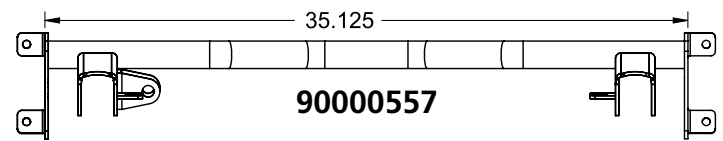

Note: The 55-57 Chevy has 2 different frame variations. The 2 piece frame has a weld seam along the bottom. 1 piece frame has no weld seam. If your car has a 1 piece frame, you need kit 11027199. If your car has a 2 piece frame, you need kit 11037199. The only difference between the 2 kits is the front crossmember. Each frame has a different measurement in the area the front crossmember bolts up. The 1 piece frame is 33 11/16", 2 piece frame is 35 1/8".

Cradle Installation



3. The parking brake brackets will be in the way of the 4 link and must be removed. Loosen the parking brake adjustment nut and remove the cable from the frame bracket. The tack weld can be broke loose with a hammer and chisel. Grind the remains of the weld smooth.



Cradle Installation



4. The rear brake line bracket on the passenger side frame rail must also be removed.



5. The front cross member will butt up against the body mount.



6. Use a couple clamps to secure the crossmember between the frame rails. Slide it forward to the edge of the body mounts. Drill the holes with a 5/16" bit and thread the 3/8" x 1" self-tapping bolts in one at a time.

Do not over tighten the self-tapping bolts; they can be stripped.



Upper Shock Mount Installation & Positioning Axle



7. The location of the upper Shockwave mount is determined by measuring from the front edge of the bracket to rear edge of the large hole in the bottom of the frame. The location of the large locating hole varies between the 1 piece frame and 2 piece frame. Use the correct measurement from below to locate your shock mount.

1 piece frame = 20 1/4"
2 piece frame = 14 1/2"



8. Use a clamp to hold the bracket against the inside of the frame and drill the holes with a 5/16" bit. Thread a 3/8" x 1" self-tapping bolt into the frame after drilling each hole.

Note there is a driver and passenger side bracket. When using the correct bracket the Shockwave mounting bolt will be perpendicular with the ground.



9. Pinion angle must be set at ride height. At ride height there should be 4 1/2" between the axle and frame. One trick to help maintain these setting while welding in the axle bracket is to tack weld a 4 1/2" long spacer between the axle and frame. **Refer to Page 8 for pinion angle setting.** After setting the pinion angle, make sure the axle is centered. This can be done by measuring from the axle flange in to the frame rail.



Setting Pinion Angle

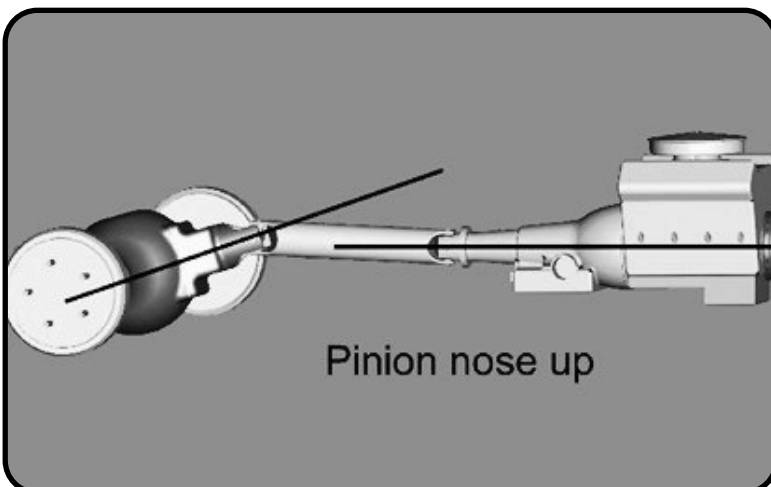
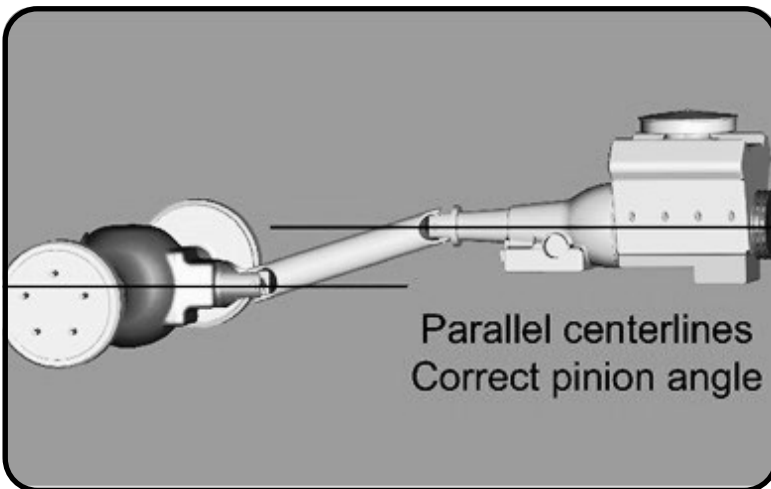
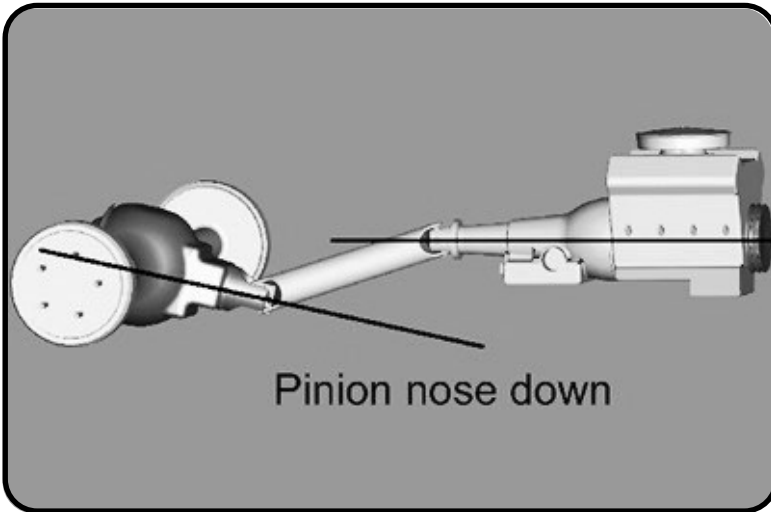

How do you set the pinion angle? On a single-piece shaft you want to set it up where a line drawn through the center of the engine crankshaft or output shaft of the transmission and a line drawn through the center of the pinion are parallel to each other but not the same line.

Your transmission angle should be around 3 degrees down in the rear. If it is more or less than 3 degrees, you might want to consider changing it. Too little angle on the transmission reduces the amount of oil getting to the rear bushing. Too much transmission angle will increase the working angles of the u-joints which will increase the wear. With the transmission at 3 degrees down in the rear, you will want to set the pinion 3 degrees up in the front.

A simple way to do this is to place a digital angle finder or dial level on the front face of the lower engine pulley or harmonic balancer. This will give you a reading that is 90 degrees to the crank or output shaft unless you have real problems with your balancer. At the other end, you can place the same level or angle finder against the front face of the pinion yoke that is also at 90 degrees to the centerline. If you rotate the yoke up or down so both angles match, you have perfect alignment.

Road testing will tell you if you have it right. If you accelerate and you get or increase a vibration, then the pinion yoke is too HIGH. Rotate it downward in small increments of a degree or two until the problem goes away. If you get or increase a vibration when decelerating, then the pinion yoke is too LOW. Rotate it upward to correct it.



Emergency Brake Cable & Bar Installation



10. Reattach the emergency brake cables to the mounts built into the front cross member.

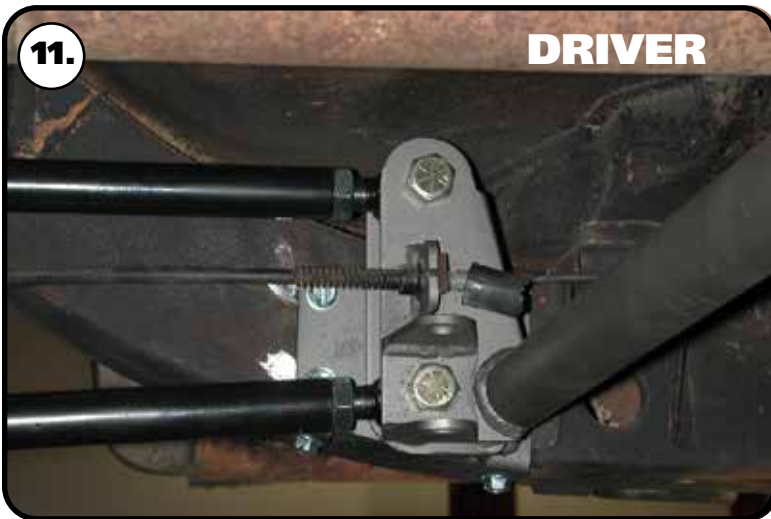

11. Insert the R-Joint spacers into the R-joint with the small OD inserted into the R-Joint center pivot. Install the 4 link bars into the crossmember. Use the 5/8" x 2 3/4" bolts and nyloks supplied in the mounting holes that don't have a diagonal bar mount. The holes that have a diagonal link bar mount use a 5/8" x 3" bolt and nylok. Tighten the bolts/nuts enough to eliminate any gaps. Check the length of the bars; they should be 18 1/2" center to center.



12. There is a driver and passenger side bracket. **The passenger side bracket has the diagonal link bracket welded to it.** Insert the R-Joint spacers into the R-joint with the small OD inserted into the R-Joint center pivot. Install the 4 link bars into the axle mounts. Use the 5/8" x 2 3/4" bolts and nyloks supplied in the mounting holes that don't have a diagonal bar mount. The holes that have a diagonal link bar mount use a 5/8" x 3" bolt and nylok. Tighten the bolts/nuts enough to eliminate any gaps.



Installing Diagonal Bar & Attaching Axle Mounts



13. Insert the R-Joint spacers into the R-joint with the small OD inserted into the R-Joint center pivot. Bolt the diagonal link into the mount on the cross member using a 5/8" x 2 3/4" bolt and nylok. It should measure 30 1/4" center to center. Tighten the bolts/nuts enough to eliminate any gaps.



14. Insert the R-Joint spacers into the R-joint with the small OD inserted into the R-Joint center pivot. Bolt the diagonal link into the mount on the passenger axle mount using a 5/8" x 2 3/4" bolt and nylok. Tighten the bolts/nuts enough to eliminate any gaps.



15. Swing the axle bracket up to the axle. These brackets must be centered and aligned with the crossmember mounts before welding. The brackets should be 31 5/8" apart on the outside measurement. Then just center it between the axle flanges. You can use a large hose clamp to hold these in place temporarily.

Tack weld the bracket to the axle. Double-check axle center, bracket alignment, and pinion angle. Remove the bars to avoid frying the bushings. Then finish welding the bracket 1" at a time in different spots to avoid warping the axle.



Lower Shock Mounts & Shockwaves/Coilovers Install



16. Bolt the lower Shockwave mount to the axle bracket using (2) 1/2"-20" x 3/4" hex head bolts. The mount offsets the lower shock stud to the outside of the car. Attach the mount to the **2 BOTTOM** holes of the axle mount. Torque the bolts to 75 ft-lbs.

Image 16 shows the Passenger side.



17. Installing the shock stud into the outer hole of the lower mount. Install a 5/8" flat washer onto the 5/8"-18 threads of the shock stud. Apply Red Loctite to the 5/8" threads of the stud. Thread the shock stud into the threaded hole of the lower mount. Repeat on both sides and torque the shock stud to 65-75 ft-lbs.

Image 17 shows the Passenger side.

Remove the Spacer from between the Axle and Frame.

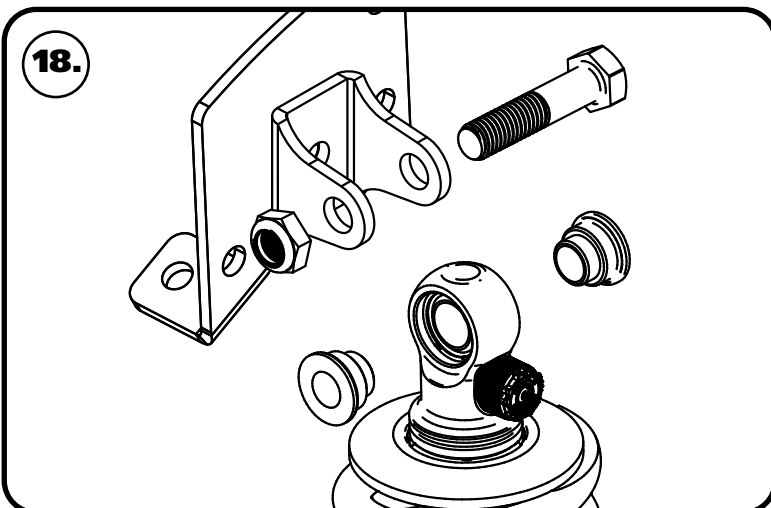

18. Install a 1/2" ID 90002043 spacer on each side of the upper Coilover/ShockWave. Slide the assembly into the upper crossmember from the bottom side. Position the adjuster knob so that the knob points toward the center of the car. Line up the hole in the spacers with the hole in the upper shock bridge and insert 1/2"-13 x 2 1/4" bolt and install 1/2"-13 thin nylok nut. Torque to 21 ft-lbs.



Installing Shockwaves/Coilovers

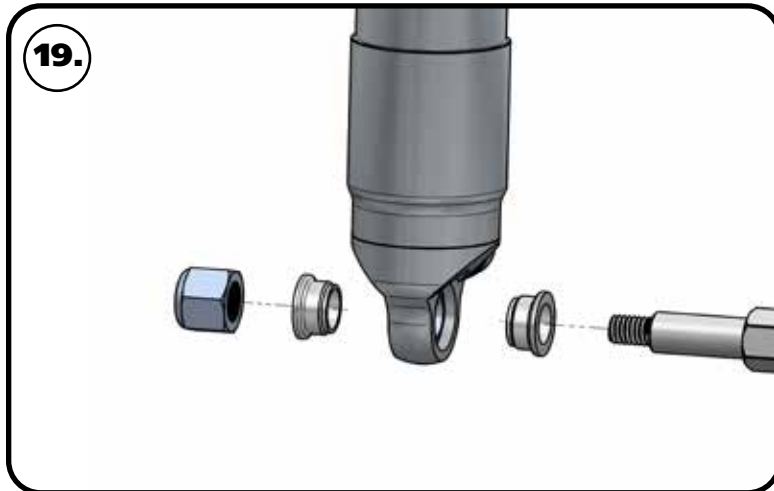

19. Install a 5/8" ID 90002067 spacer (**Small side towards shock body**) onto the lower Shock Stud. Slide the bottom of the Shock onto the Stud. Install a second 5/8" ID 90002067 Spacer onto the Stud (**small side towards shock**). You may need to jack the rearend up to Slide the Shock onto the Stud. Install the 7/16" Flat washer and 7/16" Nylok nut. Tighten the upper and lower shock bolts. Torque the Upper Bolt to 55 ftlbs and the Lower Nut to 40 ftlbs. The designed ride height of the CoilOver/ Shockwave is 12 3/4" center to center.

Note: If installing Shockwaves and you want to locate the air fitting in a different location, the air spring assembly can be rotated on the shock by grabbing the air spring assembly by hand and spinning it on the shock.



Part # 11016510

1955-1957 GM B-Body HQ Rear CoilOvers



Recommended Tools

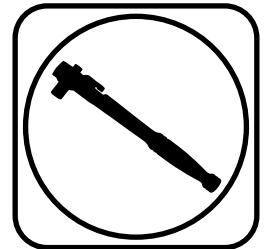

1955-1957 GM "B"Body HQ Series Rear CoilOvers

Installation Instructions

Table of contents

Page 34..... Included Components

Page 35..... Assembly and Adjusting

Page 36..... Final Adjustment and Setting Height

CoilOver Dimensions:

Center of bearing to Center of bearing:

Compressed: 10.13"

Ride Height: 12.50"

Extended: 14.23"

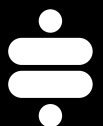



Major ComponentsIn the box

Item #	Part #	Description	QTY
1	982-10-804	4.1" Stroke HQ Series Shock	2
2	815-05-022-KIT	1.7" Shock Eyelet	2
3	90002070	3/4" Drop Cap	2
4	59100200	Coilspring 10" 200lb	2
5	70010828	Delrin Spring Washer	4
6	234-15-200	Lower Spring Adjuster Nut	2
7	99050001	Adjuster Nut Locking Screw	2
8	038-01-006-A	Retaining Ring	2
	90002043	1/2" ID Upper Bearing Spacers	4
	90001994	5/8" ID Bearing (installed in shock and eyelet)	4
	90001995	Bearing Snap Ring (installed in shock and eyelet)	8

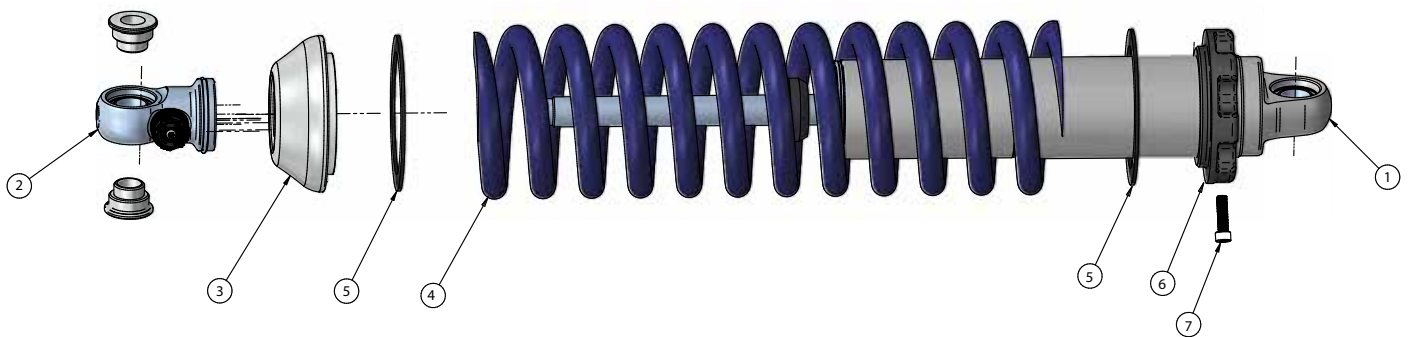

CoilOver Assembly...



1

First, using the supplied lower adjuster nut (803-00-199) thread the nut onto the shock from the bottom side as seen in figure 1. Remove the plastic pellet that is in the split of the adjuster nut.



4

Once the knob is removed slide a Delrin washer over the eyelet. Next, slide the upper spring mount (803-00-199) over eyelet as seen in figure 4.



2

Next, install a delrin washer then coil spring over the top of the shock as seen in figure 2.



5

Install upper spring mount retainer clip (803-00-199) into the groove on the upper eyelet as seen in figure 5. Then, reinstall adjuster to complete assembly.



3

Before the upper spring mount can be installed screw the adjuster knob on the upper eye mount to the firmest setting (clockwise) as seen in figure 3. Then remove the Knob by holding it while removing the center screw.

Install the locking screw in the adjuster nut before setting spring preload, but DO NOT tighten until the spring preload has been set.

NOTE: Remember to adjust the shock valving before driving, the shock is currently set to full stiff.

Shock Adjustment 101- Single Adjustable

Rebound Adjustment:

How to adjust your new shocks.

The rebound adjustment knob is located on the top of the shock absorber protruding from the eyelet. You must first begin at the ZERO setting, then set the shock to a medium setting of 12.



-Begin with the shocks adjusted to the ZERO rebound position (full stiff). Do this by rotating the rebound adjuster knob clockwise until it stops.



-Now turn the rebound adjuster knob counter clock wise 12 clicks. This sets the shock at 12. (settings 21-24 are typically too soft for street use).

Take the vehicle for a test drive.



-if you are satisfied with the ride quality, do not do anything, you are set!

-if the ride quality is too soft increase the damping effect by rotating the rebound knob clock wise 3 clicks.

Take the vehicle for another test drive.



-if the vehicle is too soft increase the damping effect by rotating the rebound knob clock wise 3 additional clicks.



-If the vehicle is too stiff rotate the rebound adjustment knob counter clock wise 2 clicks and you are set!

Take the vehicle for another test drive and repeat the above steps until the ride quality is satisfactory.

Note:

One end of the vehicle will likely reach the desired setting before the other end. If this happens stop adjusting the satisfied end and keep adjusting the unsatisfied end until the overall ride quality is satisfactory.



Final Tightening and Adjusting

Ride Height

We have designed most cars to have a ride height of about 2" lower than factory. To achieve the best ride quality & handling, the shock absorber needs to be at 40-60% overall travel when the car is at ride height. This will ensure that the shock will not bottom out or top out over even the largest bumps. Measuring the shock can be difficult, especially on some front suspensions. Measuring overall wheel travel is just as effective and can be much easier. Most cars will have 4-6" of overall wheel travel. One easy way to determine where you are at in wheel travel is to take a measurement from the fender lip (center of the wheel) to the ground. Then lift the car by the frame until the wheel is just touching the ground, re-measure. This will indicate how far you are from full extension of the shock. A minimum of 1.5" of extension travel (at the wheel) is needed to ensure that the shock does not top out. If you are more than 3" from full extension of the shock then you are in danger of bottoming out the shock absorber.

Adjusting Spring Height

When assembling the CoilOver, screw the spring retainer tight up to the spring (0 preload). After entire weight of car is on the wheels, jounce the suspension and roll the car forward and backward to alleviate suspension bind.

- If the car is too high w/ 0 preload then a smaller rate spring is required. Although threading the spring retainer down would lower the car, this could allow the spring to fall out of its seat when lifting the car by the frame.
- If the car is too low w/ 0 preload, then preload can then be added by threading the spring retainer up to achieve ride height. On 2.6" - 4" stroke shocks, up to 1.5" of preload is acceptable. On 5-7" stroke shocks, up to 2.5" of preload is acceptable. If more preload is needed to achieve ride height a stiffer spring rate is required. Too much preload may lead to coil bind, causing ride quality to suffer.