



**Installation  
Instructions**



**11020398 or 11030398**

**1955-1957 GM B-Body TQ ShockWave Kit**

**Recommended Tools**

**Front Components:**

- 11013011 Front ShockWaves
- 11012899 Front Lower StrongArms
- 11013699 Front Upper StrongArms
- 11019100 Front Sway Bar

**Rear Components:**

- 11027199/11037199 Rear 4Link System
- 24340701 Rear ShockWaves

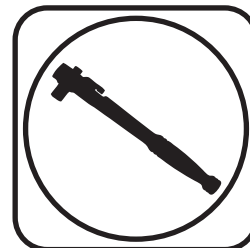
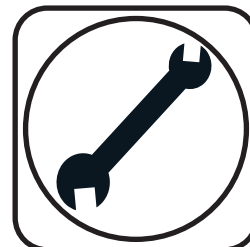

# 1955-1957 Chevy Car ShockWave Installation Instructions

**Table of contents**

- Pages 2-6..... Front ShockWaves
- Pages 7-11..... Front Lower StrongArms
- Pages 12-15..... Front Upper StrongArms
- Pages 16-20..... Front Sway Bar
- Pages 21-32..... Rear 4-Link
- Pages 33-34..... Rear ShockWaves
- Pages 35..... Notes and Care of ShockWaves
- Pages 36-37..... Shock Adjustment

[www.ridetech.com](http://www.ridetech.com)



REV6 6/14/22



**Part # 11013011 - 55-57 GM B-Body Front TQ Series ShockWave**

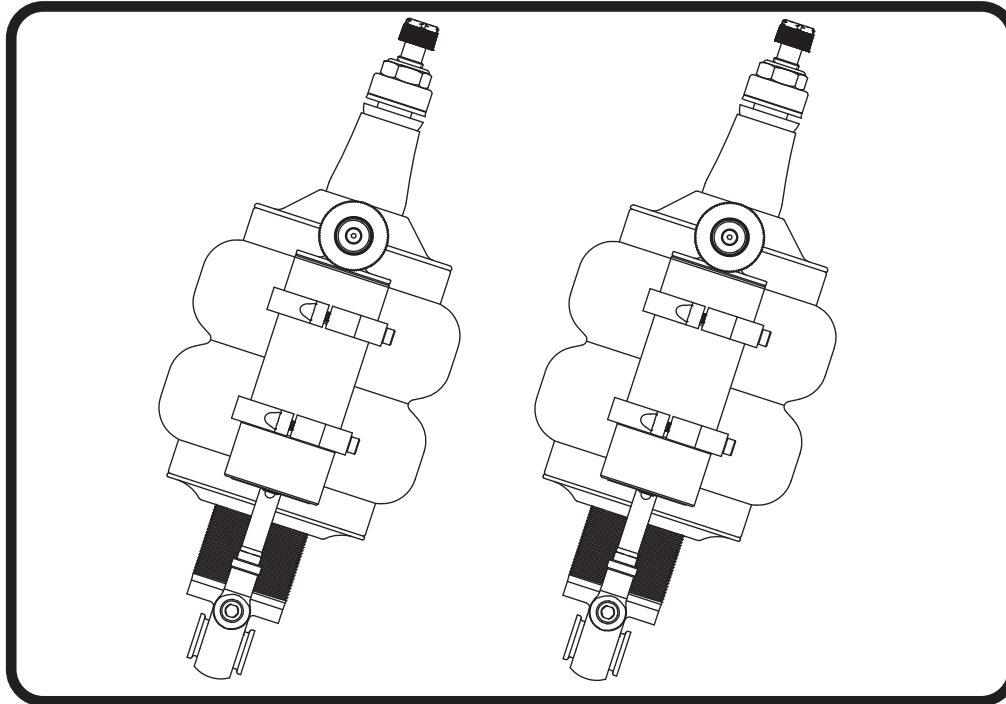

### Recommended Tools

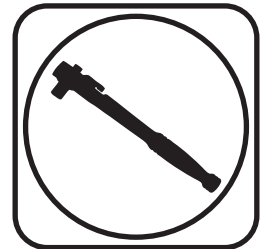

# 1000 Series Bellow, 2.00" Stud/Eye 4.1" Shock Installation Instructions

### Table of contents

Page 3..... Included components

Page 4-5..... ShockWave Installation

Page 6..... Notes and Care of Your ShockWave

### ShockWave Dimensions:

Center of bearing to Center of bearing:

Compressed: 11.00"

Ride Height: 13.10"

Extended: 14.50"

THE DELRIN BALL REQUIRES A 3/4" HOLE FOR THE FLANGE TO GO THROUGH. THIS CAN BE DRILLED WITH A UNIBIT.



### Major Components .....In the box

Item #	Part #	Description	QTY
1	986-10-071	4.1" Stroke TQ Series Shock	2
2	90009988	2.00" Stud Top (Installed on Shock) - Includes Adjuster Knob & Screw	2
3	24090199	1000 Series 6.5" Double Convoluted AirSpring	2
4	234-00-153	AirSpring Locking Ring (Installed on shock)	2
	99055000	Locking Ring Set Screw (Installed on shock)	2
7	90002312	2.00" Aluminum Stud Top Base	2
8	90001904	Bottom Delrin Ball	2
9	90001903	Top Delrin Ball	2
10	90001902	Delrin Ball Aluminum Top Cap	2
11	99562003	9/16"-18 Thin Nylok Nut	2
12	210-35-120-0	Adjuster Knob - (90009988 assembly)	2
	90009969	#4-40 X 1/4" SS, 18-8 Pan Head Torx Cap - (90009988 assembly)	2
	70012160	2.00" Stud Top Metering Rod (installed in stud top)	2
15	90001994	5/8" ID Bearing (installed in shock and eyelet)	4
16	90001995	Bearing Snap Ring (installed in shock and eyelet)	8
17	026-05-000	Reservoir Mount	4
18	99050000	Reservoir Mounting Screw - 5mm SS X .5 SHCS	12
19	99952006	Spring Washer	2
20	90009908	High Speed Adjuster Knob	2
21	90009907	Low Speed Adjuster Knob	2
22	99041000	4 -40 X .500 Button head socket cap screw	2
23	85000003	Hex Wrench for Reservoir Mounting Screws	1

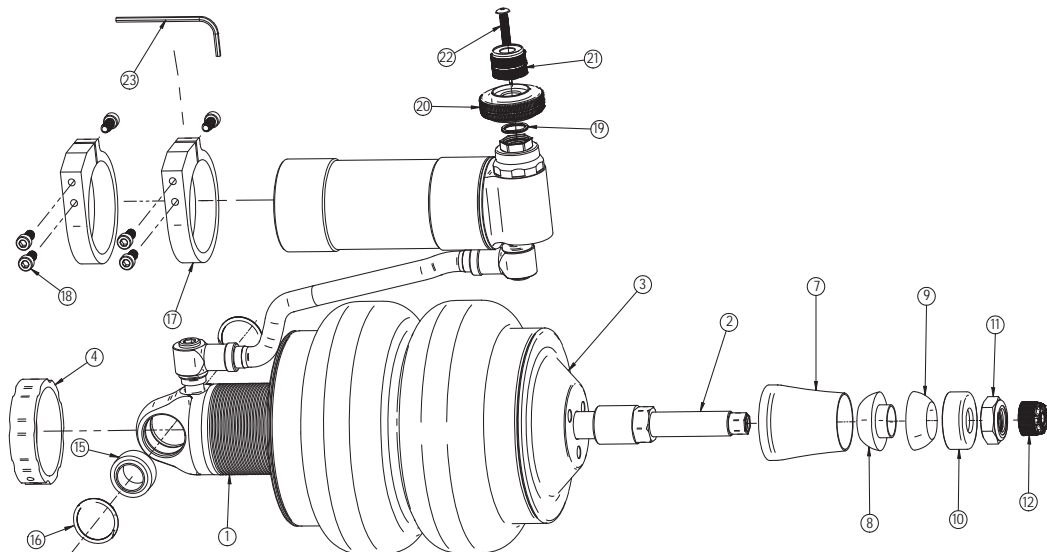

**WARNING: ATTEMPTING TO REMOVE THE AIR FITTING WILL DAMAGE IT AND VOID THE WARRANTY.**



### ShockWave Installation



1. Remove the OEM bushing flange by prying it out of the frame hole. After removing the flange, drill the OEM shock hole out to 3/4". This can be done with a Unibit.

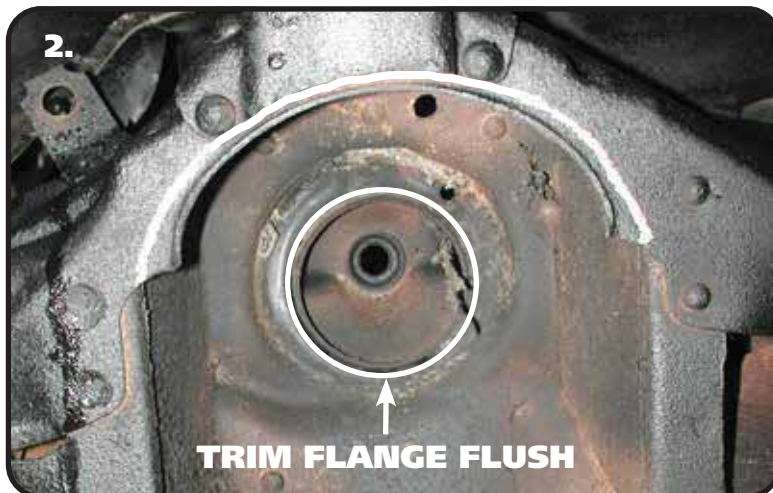

2. Trim the coil spring location ring flush to prevent the ring from hitting the top of the ShockWave Air Spring. A die grinder with a cutoff wheels works well here.



3. To allow clearance for the Shockwave, some trimming must be done on the outside edge of the coil spring pocket as shown by the white line in the picture. This is best done with either a cut off wheel or plasma cutter. Grind all cuts smooth when finished.

**Note:** It may be helpful to go ahead and install the lower StrongArms and Shockwaves to determine exactly what needs to be removed.



### ShockWave Installation

4.

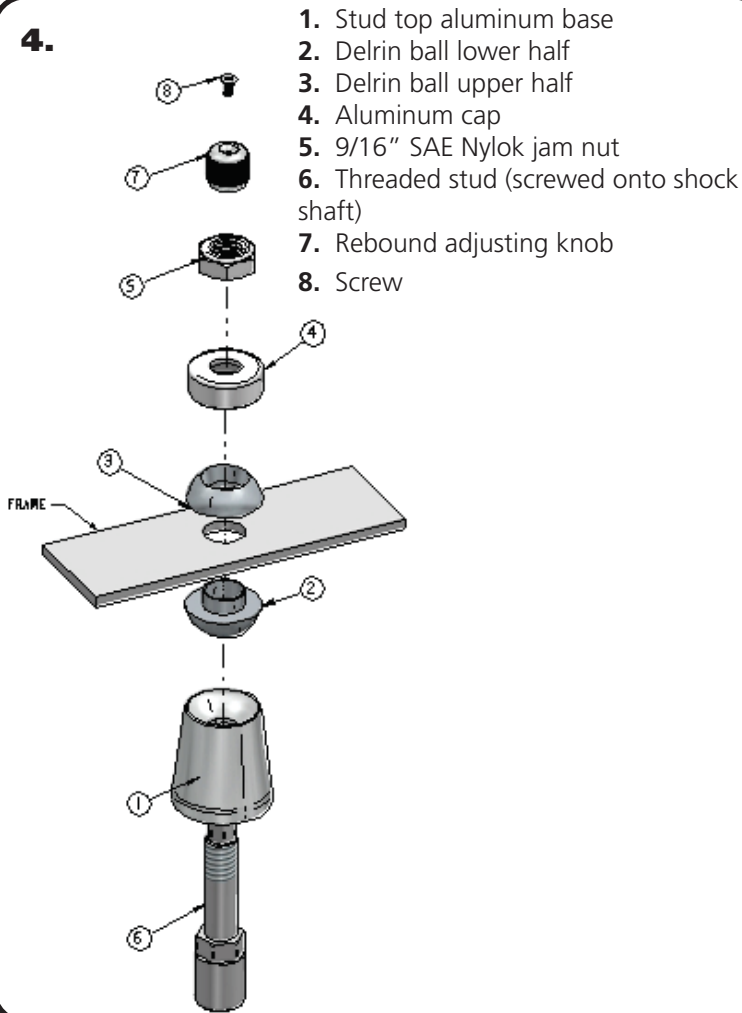

1. Stud top aluminum base
2. Delrin ball lower half
3. Delrin ball upper half
4. Aluminum cap
5. 9/16" SAE Nylok jam nut
6. Threaded stud (screwed onto shock shaft)
7. Rebound adjusting knob
8. Screw

**Note:** The airline must also be routed at this time. It can be ran through the subframe toward the rear of the vehicle.

4. The air fitting location can be rotated by twisting the bellow assembly separate of the shock. Place the Shockwave into the coil spring pocket with the stud sticking through the OEM shock hole. See assembly **Diagram 4**. OEM Shock hole **must** be drilled out to  $\frac{3}{4}$ "

1. Stud top aluminum base
2. Delrin ball lower half
3. Delrin ball upper half
4. Aluminum cap
5. 9/16" SAE Nylok jam nut
6. Threaded stud (screwed onto shock shaft)
7. Rebound adjusting knob
8. Screw

5.

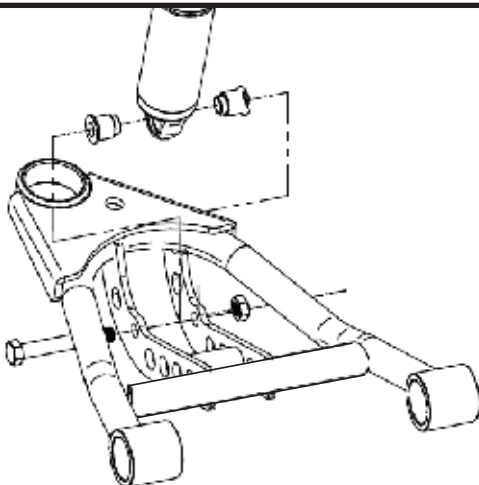

5. Raise the lower arm up to the Shockwave and bolt them together using the  $\frac{1}{2}$ " x  $3\frac{1}{4}$ " bolt and Nylok supplied w/ the lower arms. An aluminum spacer will be on each side of the bearing. Torque to 75 ftbs.

6. Raise the lower control arm to full compression and double-check to make sure the Shockwave does not rub on anything at anytime. Allowing the Shockwave to rub on anything will cause failure and is not a warrantable situation.

7. The best ride quality will occur around 50-60% suspension travel; depending on vehicle weight this typically occurs around 85-100 psi.





### Notes and Care of your Shockwaves

#### NOTES:

**WARNING: ATTEMPTING TO REMOVE THE AIR FITTING WILL DAMAGE IT AND VOID THE WARRANTY.**

**TIGHTENING THE TOP 9/16"-18 NUT:** SNUG THE NUT DOWN AGAINST THE TOP CAP. YOU NEED TO BE ABLE TO ARTICULATE THE SHOCK BY HAND. WE TORQUE THE NUT TO 80 INLBS USING A 7/8" CROWS FOOT WRENCH ON A TORQUE WRENCH.

You can clock the airfitting location on the ShockWave by turning the AirSpring assembly of the shock. Make sure the fitting doesn't contact the frame.

When cutting the airline, use a razor blade. The cut needs to be a clean cut and square for the airline to seal properly.

**The Locking ring on the shock is NOT adjustable. These rings are set at the factory to optimize the AirSpring stroke with the shock stroke.**

---

## The care and feeding of your new ShockWaves

1. Although the ShockWave has an internal bumpstop, **DO NOT DRIVE THE VEHICLE DEFLATED RESTING ON THIS BUMPSTOP. DAMAGE WILL RESULT.** The internal bumpstop will be damaged, the shock bushings will be damaged, and the vehicle shock mounting points may be damaged to the point of failure. This is a non warrantable situation.
2. Do not drive the vehicle overinflated or "topped out". Over a period of time the shock valving will be damaged, possibly to the point of failure. This is a non warrantable situation! If you need to raise your vehicle higher than the ShockWave allows, you will need a longer unit.
3. The ShockWave is designed to give a great ride quality and to raise and lower the vehicle. **IT IS NOT MADE TO HOP OR JUMP!** If you want to hop or jump, hydraulics are a better choice. This abuse will result in bent piston rods, broken shock mounts, and destroyed bushings. This is a non warrantable situation.
4. Do not let the ShockWave bellows rub on anything. Failure will result. This is a non warrantable situation.
5. The ShockWave product has been field tested on numerous vehicles as well as subjected to many different stress tests to ensure that there are no leakage or durability problems. Failures have been nearly nonexistent unless abused as described above. If the Shockwave units are installed properly and are not abused, they will last many, many years. ShockWave units that are returned with broken mounts, bent piston rods, destroyed bumpstops or bushings, or abrasions on the bellows will not be warrantied.



**Part # 11012899**

**1955-1957 GM B-Body Front Lower ShockWave/CoilOver StrongArms**



Recommended Tools

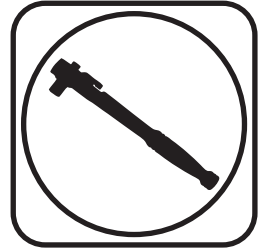

## 1955-1957 GM B-Body Lower StrongArms Installation Instructions

### Table of contents

Page 8.....	Lower Control Arm Components
Page 9.....	Getting Started & Installation
Page 10.....	StrongArm Installation
Page 11.....	Installing Spindle and Alignment





### Upper Control Arm Components ....In the box

Item #	Part Number	Description	QTY
1	90001294	Driver Lower Control Arm ( <b>Shown</b> )	1
1	90001295	Passenger Lower Control Arm	1
2	90000916 kit	Lower Ball Joint Kit - Proforged # 101-10080	2
3	90001442	Delrin Bushing	4
4	90001289	Delrin Bushing Inner Sleeve	4
5	90002694	Lower Cross Shaft Kit	1 pr
6	99433001	Outer Washer - Cross Shaft	4
7	90002062	Shock Bearing Spacers	4
8	99501005	1/2" -13 x 3 1/2" Hex Bolt GR8	2
9	99503014	1/2" SAE Flat Washer	4
10	99502009	1/2" -13 Nylok Nut	2

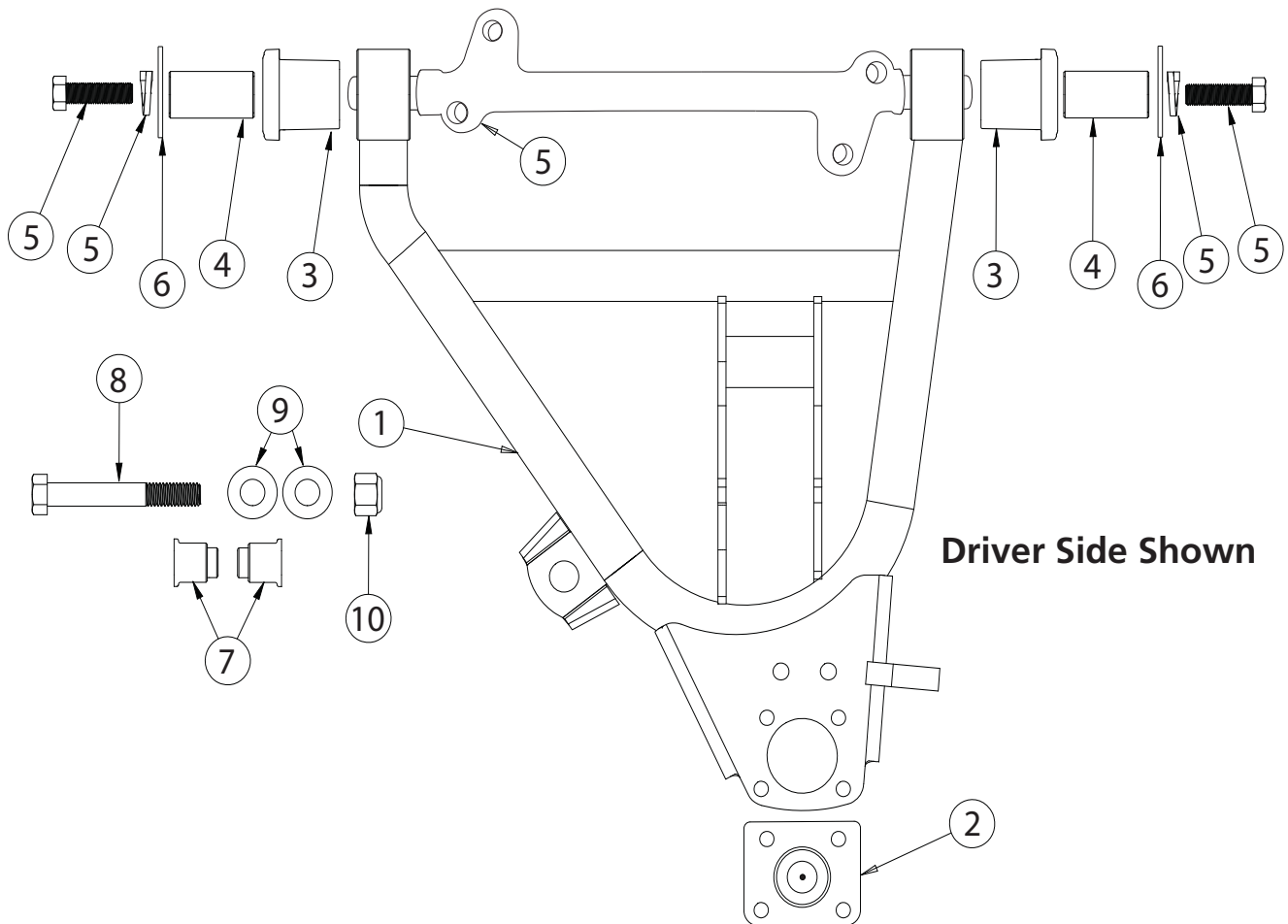





### Getting Started.....

Congratulations on your purchase of the Ridetech Tri5 StrongArms. These StrongArms have been designed to give your Tri5 excellent handling along with a lifetime of enjoyment. Some of the key features of the StrongArms: Ball joint angles have been optimized for the lowered ride height, Delrin bushings are used to eliminate bushing deflection along with providing free suspension movement through the entire travel. The Delrin bushings are made from a material that is self lubricating so no grease zerks are needed.

**When assembling the Control Arms, tighten the cross shaft bolts enough to create drag on the delrin bushings, the arm should still move through its travel by hand.**

### Installation

1. Remove the lower control arms from the car. If you are replacing the upper control arms and spindle, remove them too. Refer to a Factory Service Manual for the proper method.

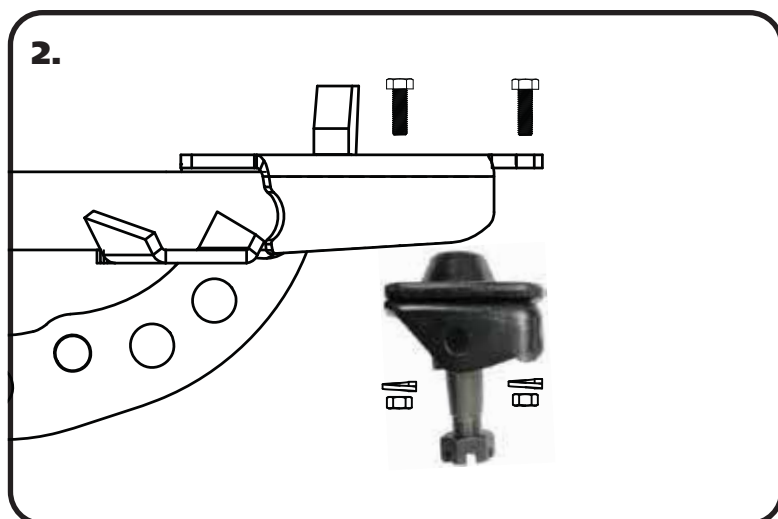

2. Insert the Ball Joint into the Control Arm from the bottom side with the Stud pointing downward. Insert the supplied Bolts from the top side. Install a Lock Washer and Hex Nut on the threads of each bolt. Torque the hardware to 25 ftlbs.

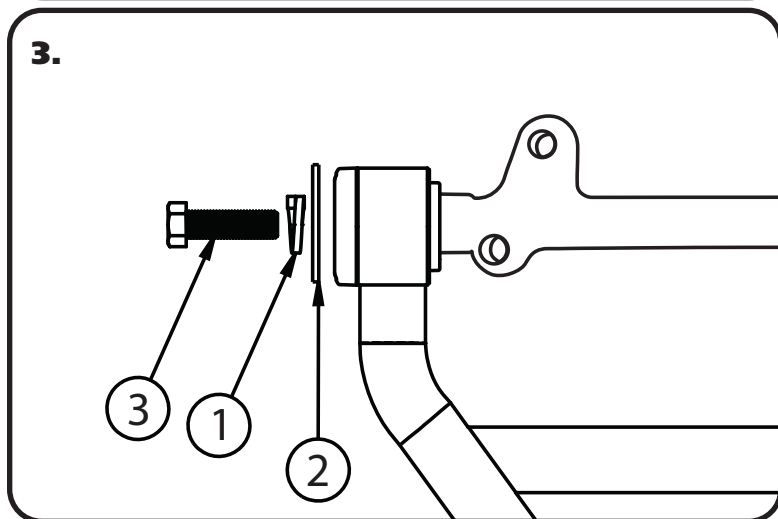

3. Install the supplied 7/16" Lock Washers & 7/16" Flat Washers on each of the (4) 7/16"-20 x 1 1/2" Bolts supplied in the kit. Thread each Bolt/Washer setup into the end of the Cross Shaft of the Lower Control Arm. Do not tighten until the control arms are installed on the car.



### Installing StrongArm

4.

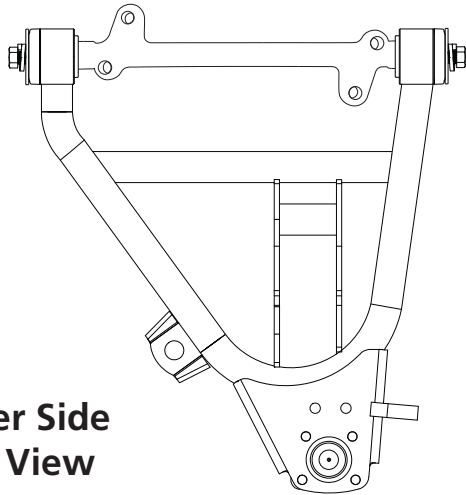

Driver Side  
Top View

4. The Lower Control Arm is attaching the frame using factory hardware. The driver side arm is shown in **Figure "2"**. The sway bar mount is located to the front of the car.

**Install the ShockWaves/CoilOvers at this time. Refer to the ShockWaves/CoilOvers instructions for Assembly.**

5.



5. The Lower Control Arm is attaching the frame using factory hardware. The driver side arm is shown in **Figure "3"**.

6.

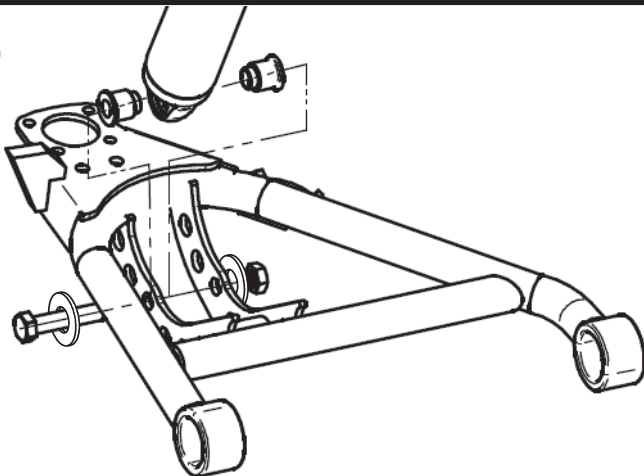

6. Bolt the Shockwave or CoilOver to the lower arm using the supplied 1/2" x 3 1/2" bolt, 1/2" flat washers, and 1/2" nylok nut. Insert the supplied aluminum spacers in each side of the shock bearing and slip it into the control arm. Line the spacers/bearing up with the 1/2" hole in the shock straps of the control arm and install hardware. Torque the hardware to 75 ftlbs.



### Installing Spindle and Alignment



7. Attach the Spindle to the control arms.

#### Torque Specs:

Ball joint - 45 ftlbs and tighten to line up cotter pin.

Install the Cotter Pin after tightening the ball joint nut.

**INSTALL THE GREASE ZERK IN THE BALL JOINT AND GREASE THE BALL JOINT AFTER ASSEMBLY.**

8. Tighten all fasteners. Connect the sway bar linkage to the new StrongArms. If you are going to install the Ridetech MuscleBar, now is a good time to do it.

**When assembling the Control Arms, tighten the cross shaft bolts enough to create drag on the delrin bushings, the arm should still move through its travel by hand.**

#### Suggested Alignment Specs:

Camber: Street: -.5 degrees  
Caster: Street: +3.0 to + 5.0 degrees  
Toe: Street: 1/16" to 1/8" toe in



### Part # 11013699 - 1955-1957 GM B-Body Front Upper StrongArms



#### Recommended Tools

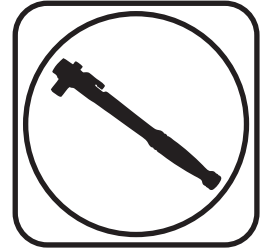

## 1955-1957 GM B-Body Upper StrongArms Installation Instructions

### Table of contents

- Page 13..... Upper Control Arm Components
- Page 14..... Getting Started & Installation
- Page 15..... Installing Spindle and Alignment



### Upper Control Arm Components ....In the box

Item #	Part Number	Description	QTY
1	90001292	Driver Upper Control Arm <b>(Shown)</b>	1
1	90001293	Passenger Upper Control Arm	1
2	90003041 kit	Tall Upper Ball Joint Kit - Proforged # 101-10477	2
3	90002695 kit	Cross Shaft Kit - contains 2 cross shafts	1
4	90001442	Delrin Bushing	4
5	90001288	Delrin Bushing Inner Sleeve	4
6	99373001	Outer Washer - Cross Shaft	4
7	99373005	3/8" Split Lock Washer -Cross Shaft	4
8	99371015	3/8"-24 x 1 1/2" Hex Bolt - Cross Shaft	4

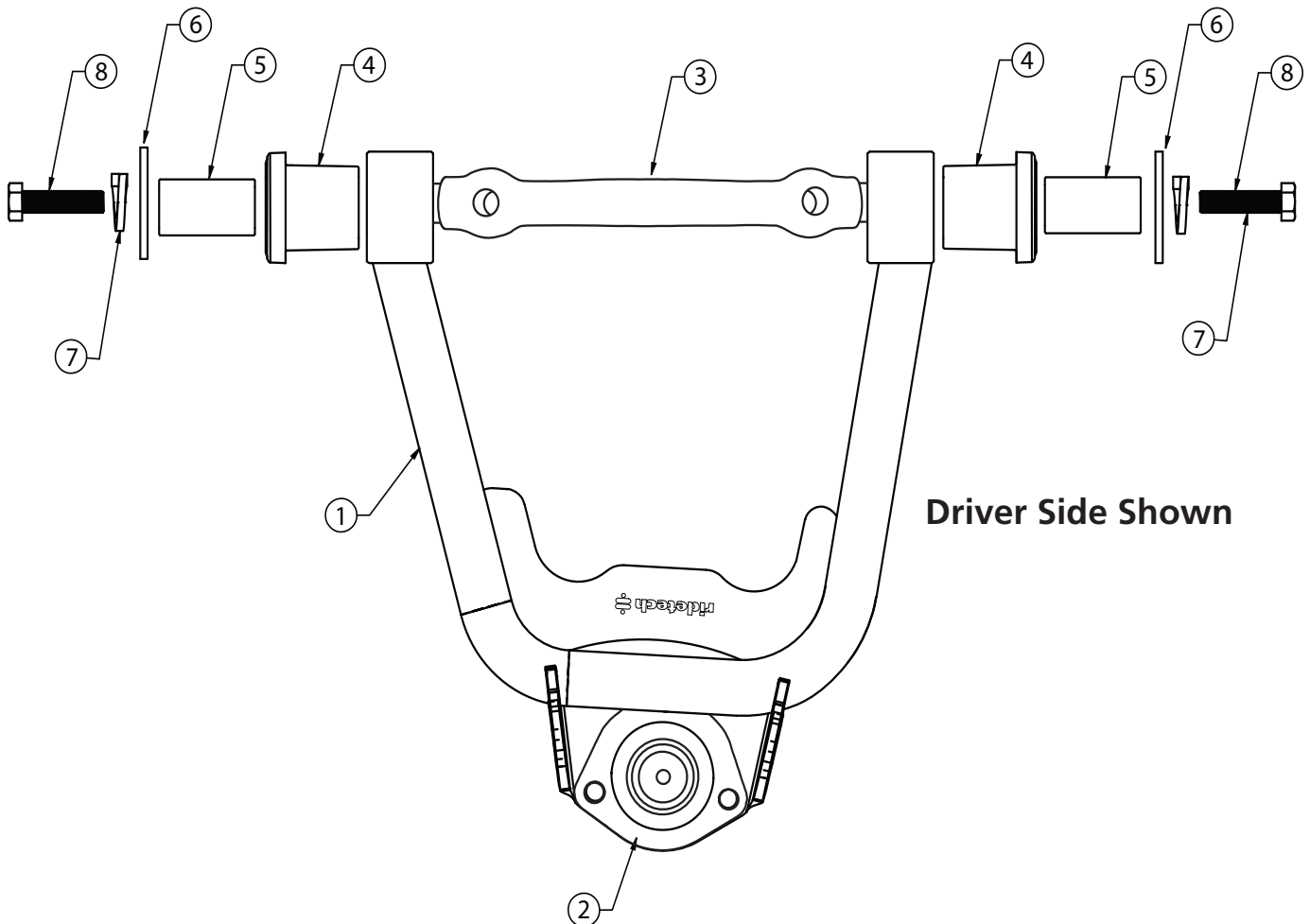



### Getting Started.....

Congratulations on your purchase of the Ridetech Tri5 StrongArms. These StrongArms have been designed to give your Tri5 excellent handling along with a lifetime of enjoyment. Some of the key features of the StrongArms: Ball joint angles have been optimized for the lowered ride height, Delrin bushings are used to eliminate bushing deflection along with providing free suspension movement through the entire travel. The Delrin bushings are made from a material that is self lubricating so no grease zerks are needed.

**When assembling the Control Arms tighten the cross shaft bolts enough to create drag on the delrin bushings, the arm should still move through its travel by hand.**

### Installation

1. Remove the upper control arms from the car. Keep the shims separate so that you can put them back in the location they were removed from. If you are replacing the lower control arms and spindle, remove them too. Refer to a Factory Service Manual for the proper method.

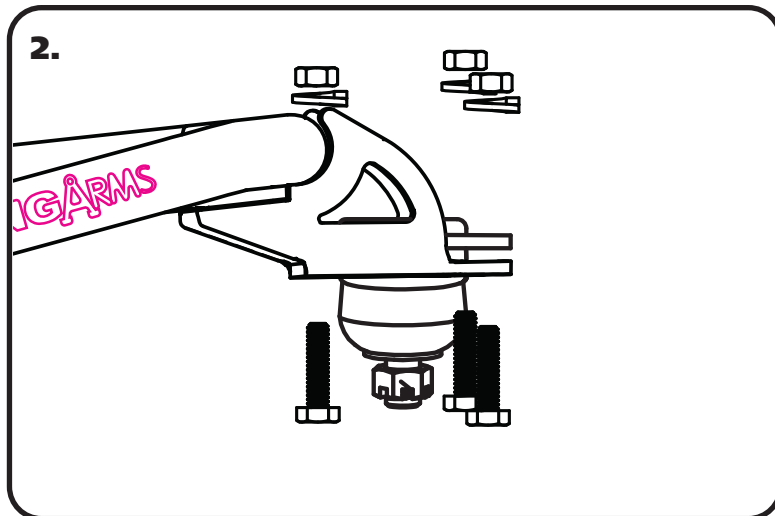

2. Insert the Ball Joint into the Control Arm from the TOP side with the Stud pointing downward. Insert the supplied Bolts from the bottom side. Install a Lock Washer and Hex Nut on the threads of each bolt. Torque the hardware to 18 ftlbs.

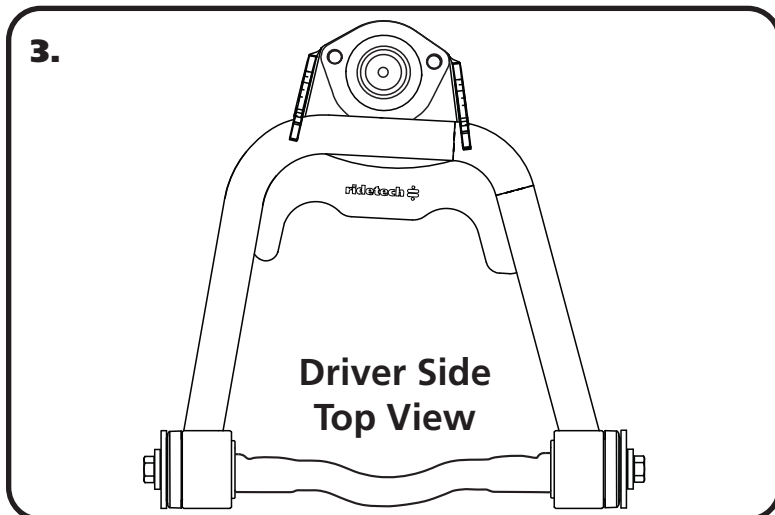

3. The Upper Control Arm is attached to the factory frame using factory hardware. The driver side arm is shown in **Figure "3"**. The Ball joint is located on the arm to the REAR of the car.





### Installing Spindle and Alignment



4. The Upper Control Arm is attaching the factory mount using factory hardware. Reinstall the shims in the location they were removed from. The passenger side arm is shown in **Figure "4"**.

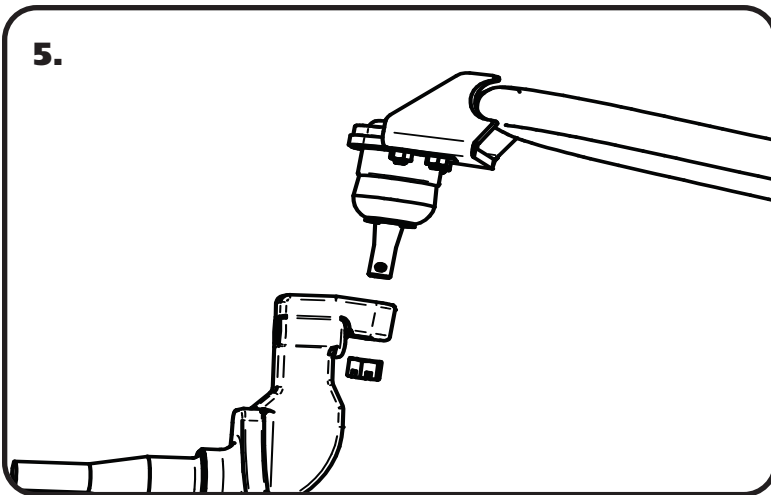

5. Attach the Spindle to the control arms. These control arms use a tall ball joint, the boot will NOT touch the spindle. This is normal.

#### Torque Specs:

Ball joint - 45 ftlbs and tighten to line up cotter pin.

Install the Cotter Pin after tightening the ball joint nut.

6. Tighten all fasteners.

**When assembling the Control Arms tighten the cross shaft bolts enough to create drag on the delrin bushings, the arm should still move through its travel by hand.**

#### Suggested Alignment Specs:

Camber: Street: -.5 degrees  
Caster: Street: +3.0 to + 5.0 degrees  
Toe: Street: 1/16" to 1/8" toe in

**DUE TO THE SHANK OF THE BALL JOINT BEING LONGER, THE BALL JOINT BOOT IS DESIGNED TO SEAL ON THE BALL JOINT SHANK. IT DOES NOT SEAL AGAINST THE SPINDLE.**



### Part # 11019100 - 1955-1957 B-Body Front Sway Bar

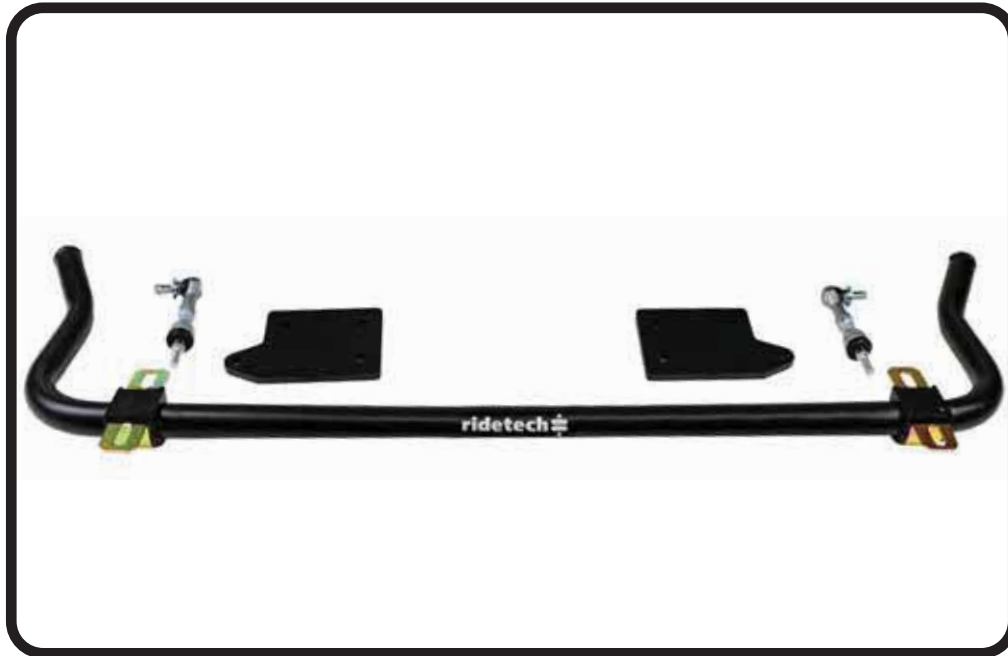

#### Recommended Tools

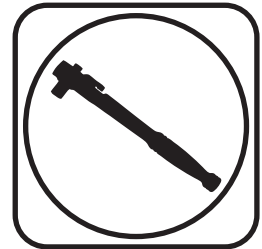

## 1955-1957 GM B-Body Front Sway Bar Installation Instructions

Table of contents	
Page 17.....	Included Components and Hardware List
Page 18.....	Sway Bar Installation
Page 19.....	Frame Mount Installation
Page 20.....	Frame Mount and PosiLink Installation

Install all Front Suspension Components before installing the Sway Bar.



### Major Components .....In the box

Part #	Description	QTY
90000731	Front Sway Bar	1
90001100	Bushing & Strap Kit	2
90000729	Sway Bar Bushing Frame Plate	2
90000717	Aluminum Step Washer - Control Arm	4
90000924	10mm Straight PosiLink - PosiLink Assembly	2
90000926	10mm 90 Degree PosiLink - PosiLink Assembly	2
99115001	10mm x 1.5" Thread Stud - PosiLink Assembly	2
90001092	Tube of Lithium Grease	1

### Hardware Kit .....99010047

Part #	Description	Usage	QTY
99371005	3/8"-16 x 1 1/4" Hex Bolt	Bushing Mount & Bushing to Frame	8
99373003	3/8" Flat washer	End link & Bushing Mounts	18
99372002	3/8"-16 Nylok Nut	End link & Bushing Mounts	8
99115006	M10 Lock Washer	PosiLink to Sway Bar	2
99112002	M10-1.5 Nylok Nut	PosiLink to Control Arm	2

### Getting Started.....

Install all front suspension components before installing the sway bar.

The Tri5 didn't come equipped with a swaybar. This kit contains the mounts needed to add a swaybar to your Tri5. If your car already has a swaybar, it will need to be removed.



1. Apply lithium grease to the poly bushing. Install the bushing over the sway bar.



### Sway Bar Installation



2. Install bushing straps over the poly sway bar bushings.

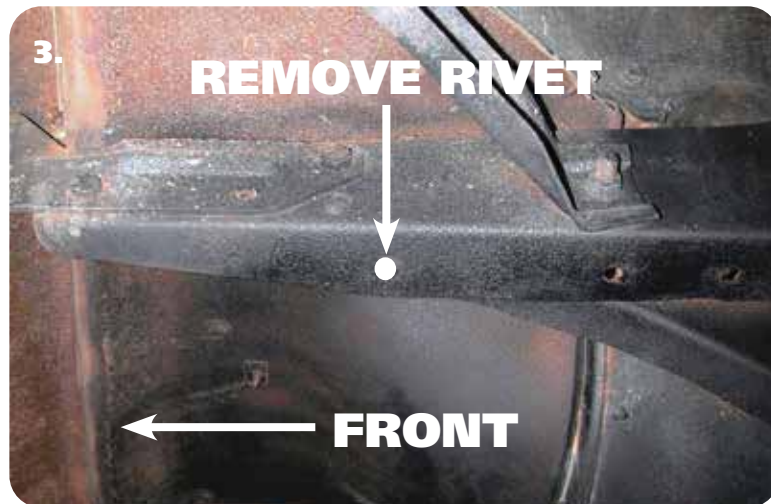

**1955-1956 FRAME MOUNT INSTALLATION**  
3. The rivet shown in **Diagram "3"** will need to be removed. This hole will be used to locate the sway bar frame mount.

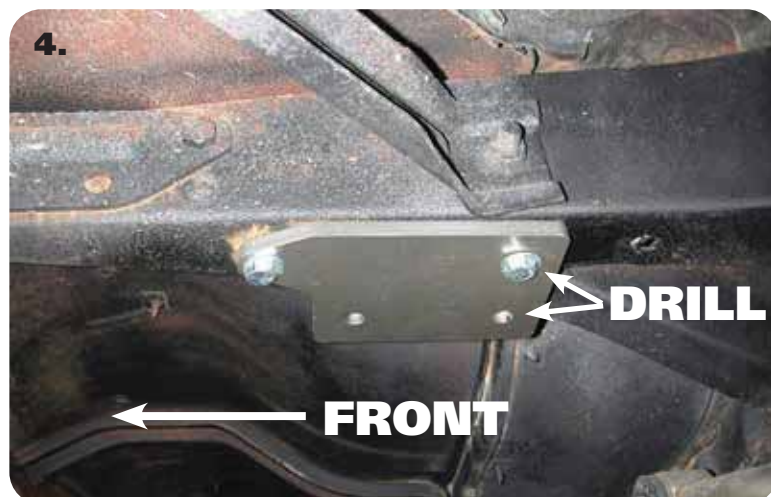

4. **Diagram "4"** shows the mounting plate installed on the driver side. Use a 3/8" flat washer on a 3/8"x 1 1/4" hex bolt to attach the frame plate to the frame. Insert the bolt into the rivet hole with the plate positioned as it is in **Diagram "5"**. With the bolt inserted into the rivet hole, use a 3/8" flat washer and 3/8" nylok nut to snug it down. Align the mounting plate parallel with the outside of the frame rail and drill the rear 2 holes through the frame. Insert a second 3/8" hex bolt and 3/8" flat washer into the rear hole with a 3/8" Flat washer and 3/8" nylok nut to tighten. Repeat process on other side and tighten hardware. The rear inner hole will be used later.





### Frame Mount Installation



5. Install 3/8" flat washers on (2) 3/8" x 1 1/4" hex bolts. Install them through the top side of the of the remaining holes in each mounting plate with the threads pointing down. The rear bolt will also go through the frame rail.



6. With the bushings and straps installed on the sway bar, put the swaybar in position on the 3/8" bolts. Attach it using 3/8" flat washers and 3/8" nylok nuts. Do **NOT** completely tighten the hardware. It will be left partially loose until the PosiLinks are installed.



### 1957 FRAME MOUNT INSTALLATION

7. There isn't a rivet to use as a locator on the 1957 frame. The frame mount is position 5" from the FRONT of the frame rail to the FRONT EDGE of the frame mount. The center of the bolt hole is 1 1/2" from the outside edge of the frame. Use the frame mount as a template to drill the 2 holes. The hardware will need to be installed from the top with the threads pointing down. Use a 3/8" x 1 1/4" hex bolt with a flat washer in each one. Do this for both sides. With the hardware installed, install a frame mount on the hardware with the SMALL bolt pattern to the inside of the car. Tighten down with a 3/8" flat washer and 3/8" nylok nut



### Frame Mount & End Link Installation



8. Install 3/8" flat washers on (2) 3/8" x 1 1/4" hex bolts and install them through the top side of the of the remaining holes in each mounting plate with the threads pointing down. With the bushings and straps installed on the sway bar, put the sway bar in position on the 3/8" bolts. Attach it using 3/8" flat washers and 3/8" nylok nuts. Do **NOT** completely tighten the hardware. It will be left partially loose until the PosiLinks are installed.



9. Bolt the 90 degree end of the PosiLink to the sway bar. A 3/8" flat washer and 10mm lock washer must be installed between the PosiLink and the bar.



10. Bolt the straight end of the PosiLink to the lower control arm. An aluminum step washer must be installed on each side of the control arm tab. Fasten with a 10mm Nylok nut. Then tighten the bushing frame bolts.





**11027199 or 11037199**

### 1955-1957 GM "B" Body Rear R-Joint Bolt-in 4 Link



#### Recommended Tools

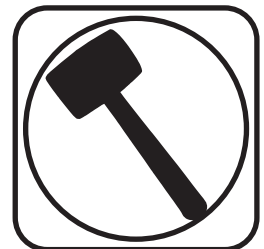
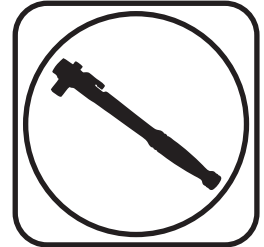

## 1955-1957 GM "B" Body Rear Bolt-in 4-Link Installation Instructions

### Table of contents

Page 22-23.....	Included Components
Page 24.....	Hardware List & Getting Started
Page 25.....	Frame Variations
Page 25-26.....	Cradle Installation
Page 27.....	Upper Shock Mount Installation
Page 27.....	Axle Positioning
Page 28.....	Setting Pinion Angle
Page 29.....	Emergency Brake Cable Installation
Page 29.....	Bar Installation
Page 30.....	Installing Diagonal Bar & Attaching Axle Mounts
Page 31.....	Installing Lower Shock Mounts
Page 31-32.....	Installing ShockWaves/CoilOvers





### Major Components .....In the box

Item #	Part #	Description	QTY
1	90000556 or 90000557	One Piece Frame Front Cross Member (33.688") or Two Piece Frame Front Cross Member (35.125")	1 or 1
2	90000160	Lower Axle Bracket - Driver	1
3	90000558	Lower Axle Bracket w/Diagonal Bracket - Passenger	1
4	90000554	Upper Shock Mount - Driver	1
5	90000555	Upper Shock Mont - Passenger	1
6	90000550	Lower Shock Mount - Driver	1
7	90000551	Lower Shock Mount - Passenger	1
8	70002825	Lower Shock Stud	2
9	90000266	Brake Line Tab	1
10	90001432	Parallel Bars - 18.500" center to center	4
11	90002853	Diagonal Bar - 30.250" center to center	1
12	70013334	R-Joint Spacers	20
	90002067	Lower Shock Spacers	4
<b>R-Joint Components - (Installed in bar ends)</b>			
	70013279	Retaining Ring	4
	70013280	Wavo Wave Spring	4
	70013275	R-Joint Center Ball	4
	70013276	R-Joint Composite Center Ball Cage	4
	90001318	RH R-Joint Threaded Housing End (installed in bars)	5
	90001319	LH R-Joint Threaded Housing End (installed in bars)	1
	99752004	RH 3/4"-16 Jam Nut (installed on bar ends)	5
	99752006	LH 3/4"-16 Jam Nut (installed on bar ends)	1

New R-Joints will be quite stiff (75-90 in/lbs breakaway torque) until they "break in" after a few miles of use. After the break in period they will move much more freely. Because the composite bearing race contains self lubricating ingredients, no additional lubrication is needed or desired. Any additional lubrication will only serve to attract more dirt and debris to the R-Joint and actually shorten its life.



### Major Components .....In the box

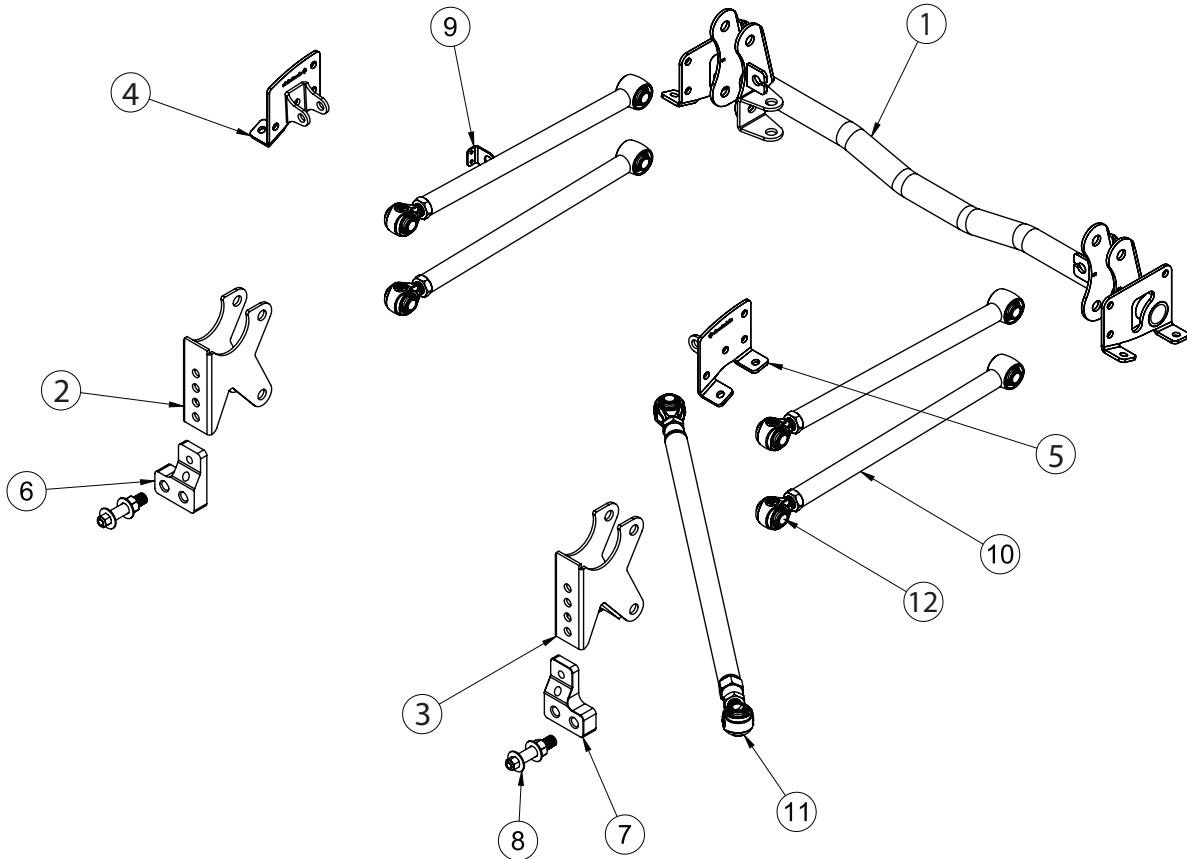

#### R-JOINT SPACER INSTALLATION

Install the Spacers by inserting the SMALL side of the SPACER into the Center Pivot Ball. Push them in until they bottom out and stop.

#### ALL R-JOINTS

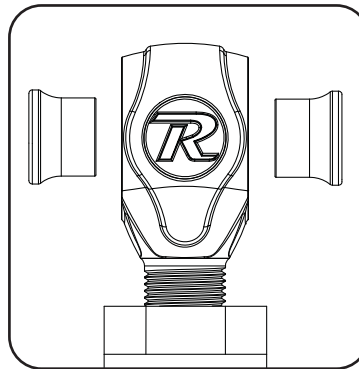

New R-Joints will be quite stiff (75-90 in/lbs breakaway torque) until they "break in" after a few miles of use. After the break in period they will move much more freely. Because the composite bearing race contains self lubricating ingredients, no additional lubrication is needed or desired. Any additional lubrication will only serve to attract more dirt and debris to the R-Joint and actually shorten its life.



### Hardware List .....In the box (Kit# 99010019)

The Hardware Kit contains bags to help aid in selecting the correct hardware for the component being installed. The hardware list shows how the hardware is bagged.

QTY	Part Number	Description	QTY	Part Number	Description
<b>FRONT CROSS MEMBER MOUNTING</b>			<b>UPPER SHOCK MOUNTING</b>		
10	99373007	3/8"-16 x 1" Thread Forming	10	99373007	3/8"-16 x 1" Thread Forming
10	99373005	3/8" Lock Washer	10	99373005	3/8" Lock Washer
<b>4 LINK BARS</b>			2	99501026	1/2"-13 X 2 1/4" Hex Bolt
8	99621020	5/8"-11 X 2 3/4" Hex Bolt	2	99502007	1/2"-13 Nylok Jam Nut
2	99621017	5/8"-11 x 3" Hex Bolt	<b>SHOCK STUD</b>		
10	99622008	5/8"-11 Nylok Jam Nut	2	99432002	7/16"-20 Nylok Nut
<b>LOWER SHOCK MOUNT</b>			2	99433002	7/16" SAE Flat Washer
4	99501020	1/2"-20 X 3/4" Hex Bolt	2	99623004	5/8" SAE Flat Washer
<b>BRAKE LINE BRACKET</b>					
2	99101009	#10 x 3/4" Tek Screw			

### Getting Started.....

Congratulations on your purchase of the Ridetech Rear 4-link System. This system has been designed to give your Tri-5 excellent handling along with a lifetime of enjoyment. This kit replaces the Leaf Springs, this allows the 4-Link to locate the rearend and the CoilOvers/ShockWaves to support the car. This allows each to be optimized for the best performance.

**Note:** These system is designed for use with the Ridetech Shockwaves or CoilOvers and the MuscleBar swaybar. **The factory shocks and springs will not fit this setup.**

**This kit requires welding of the axle mounts to the differential. The front cross member and shocks mounts can also be welded in if you prefer.**

1. Raise the vehicle to a safe and comfortable working height. Use jack stands to support the vehicle with the suspension hanging freely. You will need a method of raising and lowering the differential.
2. Support the axle and remove the leaf springs, shocks, bump stops, pinion snubber and tail pipes. Refer to the factory service manual for proper disassembly procedures.



### Frame Rail Variations

#### 1 Piece Frame - Kit 11027199



#### 2 Piece Frame - Kit 11037199



1 Piece Frame Crossmember

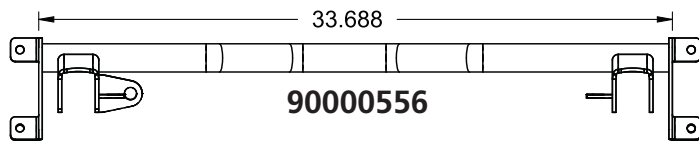

2 Piece Frame Crossmember

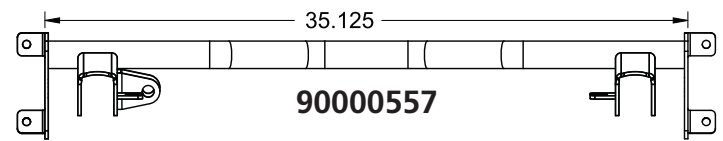

**Note:** The 55-57 Chevy has 2 different frame variations. The 2 piece frame has a weld seam along the bottom. 1 piece frame has no weld seam. If your car has a 1 piece frame, you need kit 11027199. If your car has a 2 piece frame, you need kit 11037199. The only difference between the 2 kits is the front crossmember. Each frame has a different measurement in the area the front crossmember bolts up. The 1 piece frame is 33 11/16", 2 piece frame is 35 1/8".

### Cradle Installation



**3.** The parking brake brackets will be in the way of the 4 link and must be removed. Loosen the parking brake adjustment nut and remove the cable from the frame bracket. The tack weld can be broke loose with a hammer and chisel. Grind the remains of the weld smooth.





### Cradle Installation



4. The rear brake line bracket on the passenger side frame rail must also be removed.



5. The front cross member will butt up against the body mount.



6. Use a couple clamps to secure the crossmember between the frame rails. Slide it forward to the edge of the body mounts. Drill the holes with a 5/16" bit and thread the 3/8" x 1" self-tapping bolts in one at a time.

**Do not over tighten the self-tapping bolts; they can be stripped.**





### Upper Shock Mount Installation & Positioning Axle



7. The location of the upper Shockwave mount is determined by measuring from the front edge of the bracket to rear edge of the large hole in the bottom of the frame. The location of the large locating hole varies between the 1 piece frame and 2 piece frame. Use the correct measurement from below to locate your shock mount.

**1 piece frame = 20 1/4"**  
**2 piece frame = 14 1/2"**



8. Use a clamp to hold the bracket against the inside of the frame and drill the holes with a 5/16" bit. Thread a 3/8" x 1" self-tapping bolt into the frame after drilling each hole.

**Note there is a driver and passenger side bracket. When using the correct bracket the Shockwave mounting bolt will be perpendicular with the ground.**



9. Pinion angle must be set at ride height. At ride height there should be 4 1/2" between the axle and frame. One trick to help maintain these setting while welding in the axle bracket is to tack weld a 4 1/2" long spacer between the axle and frame. **Refer to Page 8 for pinion angle setting.** After setting the pinion angle, make sure the axle is centered. This can be done by measuring from the axle flange in to the frame rail.



### Setting Pinion Angle

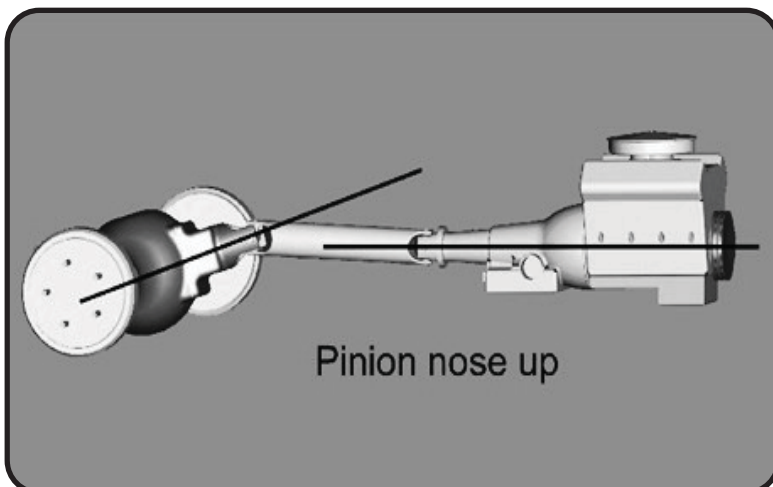
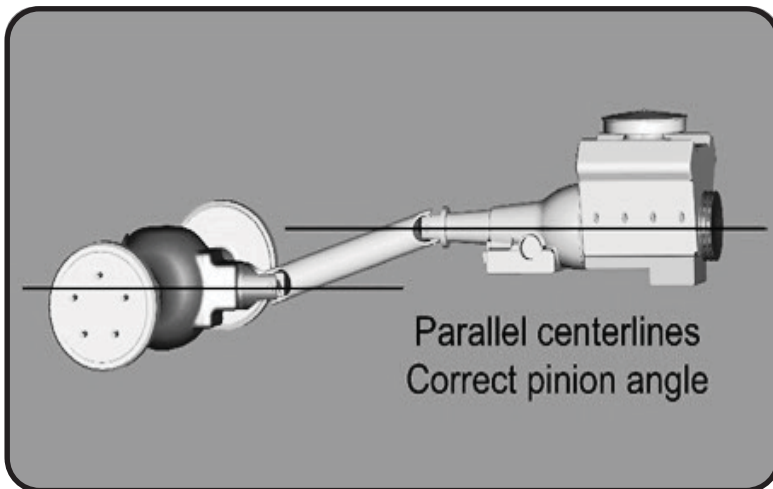
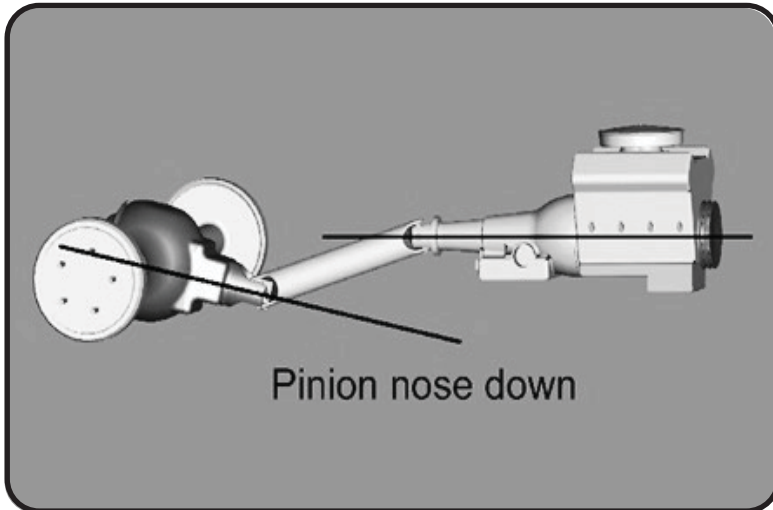

How do you set the pinion angle? On a single-piece shaft you want to set it up where a line drawn through the center of the engine crankshaft or output shaft of the transmission and a line drawn through the center of the pinion are parallel to each other but not the same line.

Your transmission angle should be around 3 degrees down in the rear. If it is more or less than 3 degrees, you might want to consider changing it. Too little angle on the transmission reduces the amount of oil getting to the rear bushing. Too much transmission angle will increase the working angles of the u-joints which will increase the wear. With the transmission at 3 degrees down in the rear, you will want to set the pinion 3 degrees up in the front.

A simple way to do this is to place a digital angle finder or dial level on the front face of the lower engine pulley or harmonic balancer. This will give you a reading that is 90 degrees to the crank or output shaft unless you have real problems with your balancer. At the other end, you can place the same level or angle finder against the front face of the pinion yoke that is also at 90 degrees to the centerline. If you rotate the yoke up or down so both angles match, you have perfect alignment.

Road testing will tell you if you have it right. If you accelerate and you get or increase a vibration, then the pinion yoke is too HIGH. Rotate it downward in small increments of a degree or two until the problem goes away. If you get or increase a vibration when decelerating, then the pinion yoke is too LOW. Rotate it upward to correct it.



### Emergency Brake Cable & Bar Installation



10. Reattach the emergency brake cables to the mounts built into the front cross member.

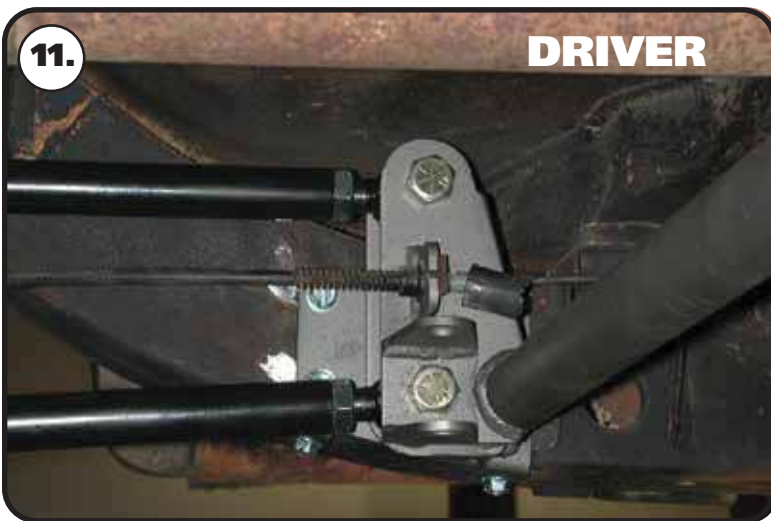

11. Insert the R-Joint spacers into the R-joint with the small OD inserted into the R-Joint center pivot. Install the 4 link bars into the crossmember. Use the 5/8" x 2 3/4" bolts and nyloks supplied in the mounting holes that don't have a diagonal bar mount. The holes that have a diagonal link bar mount use a 5/8" x 3" bolt and nylok. Tighten the bolts/nuts enough to eliminate any gaps. Check the length of the bars; they should be 18 1/2" center to center.



12. There is a driver and passenger side bracket. **The passenger side bracket has the diagonal link bracket welded to it.** Insert the R-Joint spacers into the R-joint with the small OD inserted into the R-Joint center pivot. Install the 4 link bars into the axle mounts. Use the 5/8" x 2 3/4" bolts and nyloks supplied in the mounting holes that don't have a diagonal bar mount. The holes that have a diagonal link bar mount use a 5/8" x 3" bolt and nylok. Tighten the bolts/nuts enough to eliminate any gaps.





### Installing Diagonal Bar & Attaching Axle Mounts



**13.** Insert the R-Joint spacers into the R-joint with the small OD inserted into the R-Joint center pivot. Bolt the diagonal link into the mount on the cross member using a 5/8" x 2 3/4" bolt and nylok. It should measure 30 1/4" center to center. Tighten the bolts/nuts enough to eliminate any gaps.

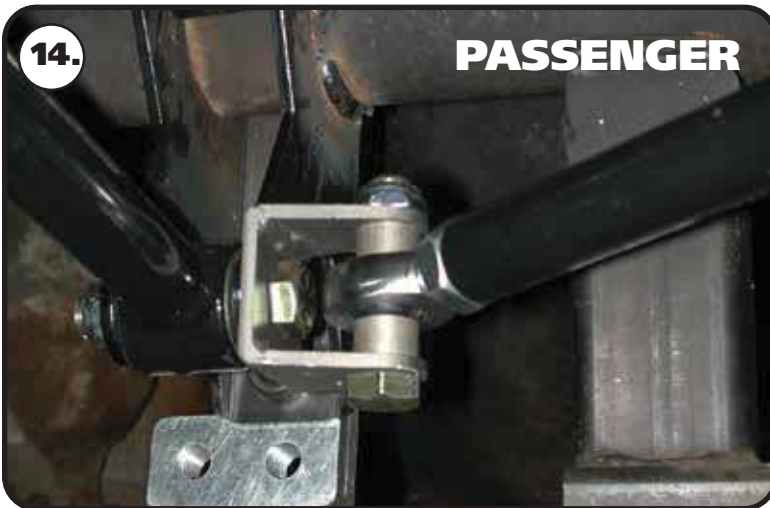

**14.** Insert the R-Joint spacers into the R-joint with the small OD inserted into the R-Joint center pivot. Bolt the diagonal link into the mount on the passenger axle mount using a 5/8" x 2 3/4" bolt and nylok. Tighten the bolts/nuts enough to eliminate any gaps.



**15.** Swing the axle bracket up to the axle. These brackets must be centered and aligned with the crossmember mounts before welding. The brackets should be 31 5/8" apart on the outside measurement. Then just center it between the axle flanges. You can use a large hose clamp to hold these in place temporarily.

Tack weld the bracket to the axle. Double-check axle center, bracket alignment, and pinion angle. Remove the bars to avoid frying the bushings. Then finish welding the bracket 1" at a time in different spots to avoid warping the axle.



### Lower Shock Mounts & Shockwaves/Coilovers Install



**16.** Bolt the lower Shockwave mount to the axle bracket using (2) 1/2"-20" x 3/4" hex head bolts. The mount offsets the lower shock stud to the outside of the car. Attach the mount to the **2 BOTTOM** holes of the axle mount. Torque the bolts to 75 ft-lbs.

**Image 16** shows the Passenger side.



**17.** Installing the shock stud into the outer hole of the lower mount. Install a 5/8" flat washer onto the 5/8"-18 threads of the shock stud. Apply Red Loctite to the 5/8" threads of the stud. Thread the shock stud into the threaded hole of the lower mount. Repeat on both sides and torque the shock stud to 65-75 ft-lbs.

**Image 17** shows the Passenger side.

**Remove the Spacer from between the Axle and Frame.**

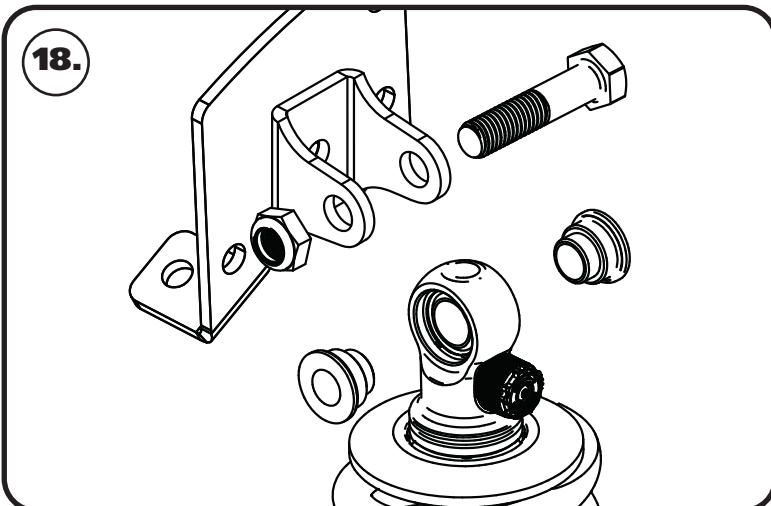

**18.** Install a 1/2" ID 90002043 spacer on each side of the upper Coilover/ShockWave. Slide the assembly into the upper crossmember from the bottom side. Position the adjuster knob so that the knob points toward the center of the car. Line up the hole in the spacers with the hole in the upper shock bridge and insert 1/2"-13 x 2 1/4" bolt and install 1/2"-13 thin nylok nut. Torque to 21 ft-lbs.



### Installing Shockwaves/Coilovers

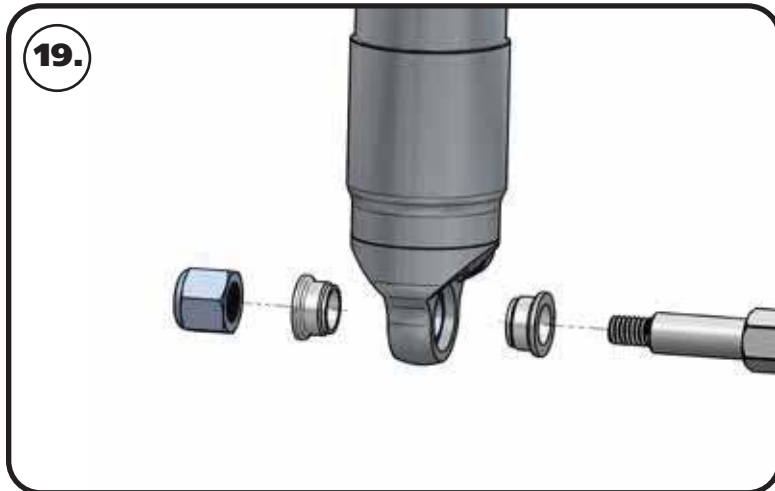

**19.** Install a 5/8" ID 90002067 spacer (**Small side towards shock body**) onto the lower Shock Stud. Slide the bottom of the Shock onto the Stud. Install a second 5/8" ID 90002067 Spacer onto the Stud (**small side towards shock**). You may need to jack the rearend up to Slide the Shock onto the Stud. Install the 7/16" Flat washer and 7/16" Nylok nut. Tighten the upper and lower shock bolts. Torque the Upper Bolt to 55 ftlbs and the Lower Nut to 40 ftlbs. The designed ride height of the CoilOver/ Shockwave is 12 3/4" center to center.

**Note:** If installing Shockwaves and you want to locate the air fitting in a different location, the air spring assembly can be rotated on the shock by grabbing the air spring assembly by hand and spinning it on the shock.





### Part # 24340701 - 4.1" Stroke TQ Series Shockwave

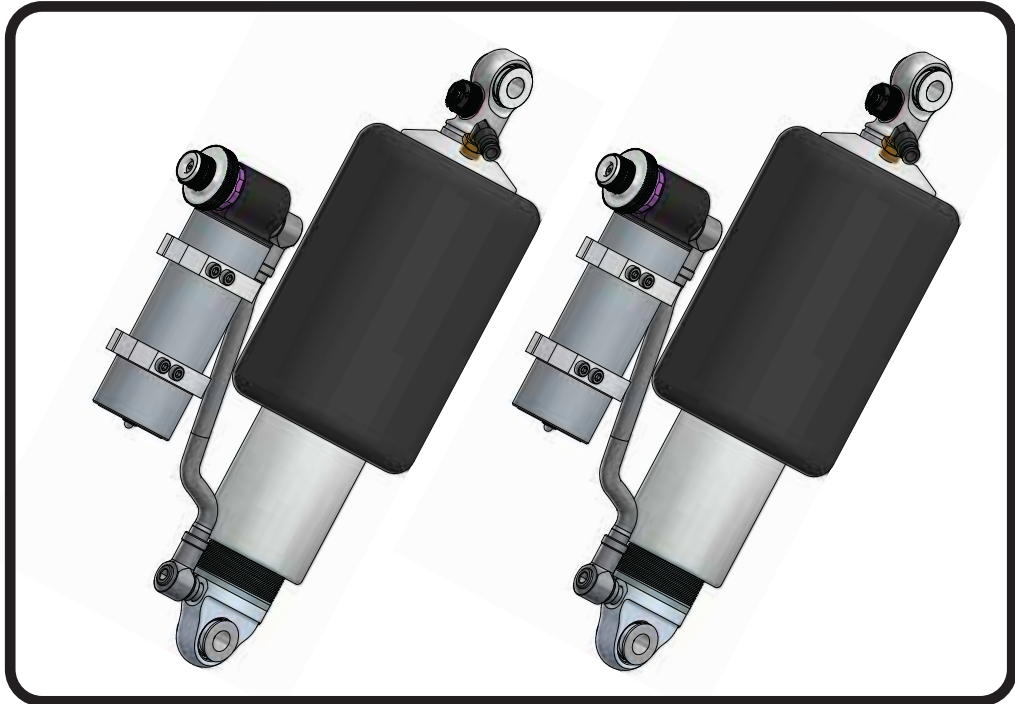

#### Recommended Tools



# 7000 Series Bellow, Eye/Eye 4.1" Shock Installation Instructions

Table of contents

Page 34..... Included components

Page 35..... Notes and Care of Your Shockwave

Page 36..... Shock Adjustment

Page 37..... Shock Adjustment

ShockWave Dimensions:

Center of bearing to Center of bearing:	
Compressed:	10.75"
Ride Height:	12.83"
Extended:	14.22"



### Major Components .....In the box

Item #	Part #	Description	QTY
1	986-10-071	4.1" Stroke TQ Series Shock	2
2	815-05-022-KIT	1.7" Shock Eyelet	2
3	24090799	7000 Series 4" Rolling Sleeve AirSpring	2
4	234-00-153	AirSpring Locking Ring (Installed on Shock)	2
	90002044	Spacer kit - 1/2" ID and 5/8" ID (Not Shown)	4
6	026-05-000	Reservoir Clamps	4
7	99050000	Reservoir Socket Head Cap Screws	12
8	90001994	5/8" ID Bearing (installed in shock and eyelet)	4
9	90001995	Bearing Snap Ring (installed in shock and eyelet)	8

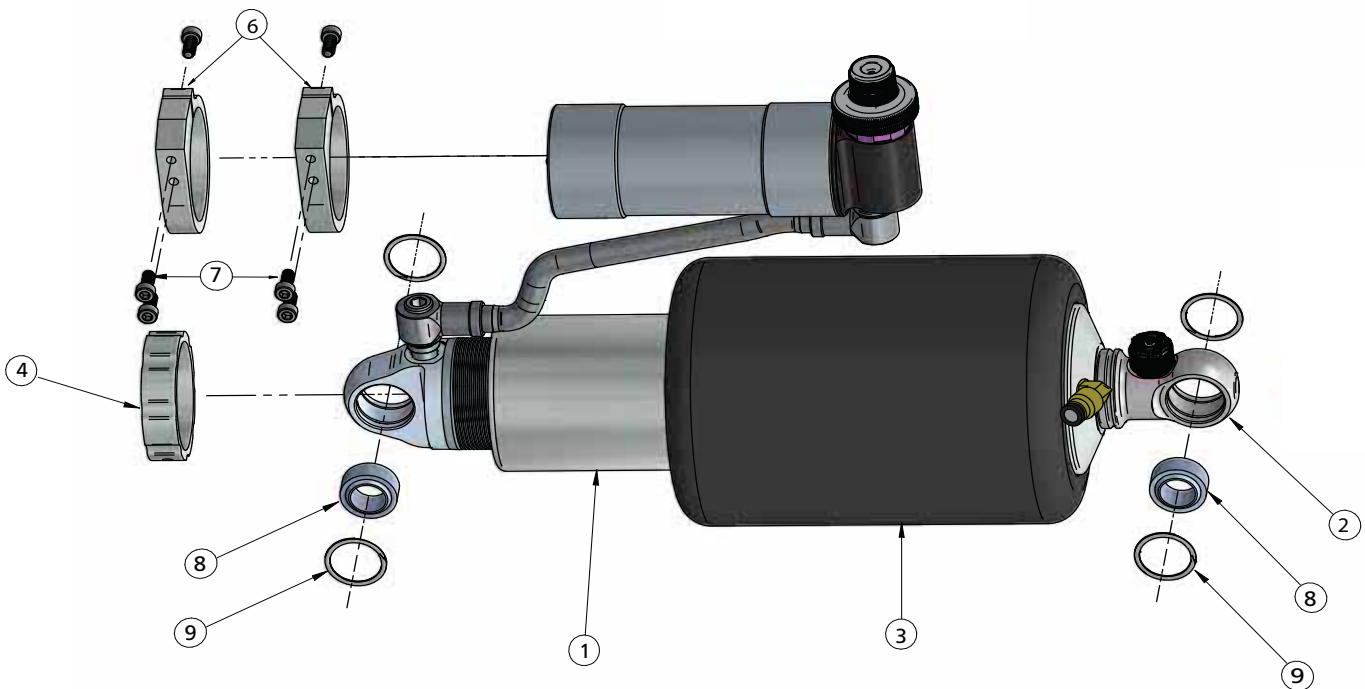

**WARNING: ATTEMPTING TO REMOVE THE AIR FITTING WILL DAMAGE IT AND VOID THE WARRANTY.**



### Notes and Care of your Shockwaves

#### NOTES:

**WARNING: ATTEMPTING TO REMOVE THE AIR FITTING WILL DAMAGE IT AND VOID THE WARRANTY.**

You can clock the airfitting location on the ShockWave by turning the AirSpring assembly of the shock. Make sure the fitting doesn't contact the frame.

When cutting the airline, use a razor blade. The cut needs to be a clean cut and square for the airline to seal properly.

The Locking ring on the shock is **NOT** adjustable. These rings are set at the factory to optimize the AirSpring stroke with the shock stroke.

### The care and feeding of your new ShockWaves

1. Although the ShockWave has an internal bumpstop, **DO NOT DRIVE THE VEHICLE DEFLATED RESTING ON THIS BUMPSTOP. DAMAGE WILL RESULT.** The internal bumpstop will be damaged, the shock bushings will be damaged, and the vehicle shock mounting points may be damaged to the point of failure. This is a non warrantable situation.
2. Do not drive the vehicle overinflated or "topped out". Over a period of time the shock valving will be damaged, possibly to the point of failure. This is a non warrantable situation! If you need to raise your vehicle higher than the ShockWave allows, you will need a longer unit.
3. The ShockWave is designed to give a great ride quality and to raise and lower the vehicle. **IT IS NOT MADE TO HOP OR JUMP!** If you want to hop or jump, hydraulics are a better choice. This abuse will result in bent piston rods, broken shock mounts, and destroyed bushings. This is a non warrantable situation.
4. Do not let the ShockWave bellows rub on anything. Failure will result. This is a non warrantable situation.
5. The ShockWave product has been field tested on numerous vehicles as well as subjected to many different stress tests to ensure that there are no leakage or durability problems. Failures have been nearly nonexistent unless abused as described above. If the Shockwave units are installed properly and are not abused, they will last many, many years. ShockWave units that are returned with broken mounts, bent piston rods, destroyed bumpstops or bushings, or abrasions on the bellows will not be warrantied.



### Shock Adjustment

#### Shock Adjustment 101- Single Adjustable

##### Rebound Adjustment:

How to adjust your new shocks.

The rebound adjustment knob is located on the top of the shock absorber protruding from the eyelet.

You must first begin at the ZERO setting, then set the shock to a medium setting of 12.



-Begin with the shocks adjusted to the ZERO rebound position (full stiff). Do this by rotating the rebound adjuster knob clockwise until it stops.

-Now turn the rebound adjuster knob counter clock wise 12 clicks. This sets the shock at 12. (settings 21-24 are typically too soft for street use).

##### Take the vehicle for a test drive.



-if you are satisfied with the ride quality, do not do anything, you are set!

-if the ride quality is too soft increase the damping effect by rotating the rebound knob clock wise 3 clicks.

##### Take the vehicle for another test drive.



-if the vehicle is too soft increase the damping effect by rotating the rebound knob clock wise 3 additional clicks.

-If the vehicle is too stiff rotate the rebound adjustment knob counter clock wise 2 clicks and you are set!

Take the vehicle for another test drive and repeat the above steps until the ride quality is satisfactory.

##### Note:

**One end of the vehicle will likely reach the desired setting before the other end. If this happens stop adjusting the satisfied end and keep adjusting the unsatisfied end until the overall ride quality is satisfactory.**



## Shock Adjustment

### Shock Adjustment 101-Triple Adjustable

#### Triple Adjustable:

#### Step One: High Speed Compression



-High speed compression adjustments are used in both street driving and track tuning.

-Begin with the shocks adjusted to the ZERO high speed compression position (full stiff). Do this by rotating the high speed compression adjuster (large knob) clockwise until it stops.



-Now turn the high speed compression adjuster knob counter clock wise 20 clicks. This sets the shock at 20. (settings 21-24 are typically too soft for street use. For typical street driving the high speed compression adjuster will remain at setting 20.

#### Step Two: Low Speed Compression

Low speed compression adjustment is what is typically felt during street driving.



-Begin with the shocks adjusted to the ZERO low speed compression position (full stiff). Do this by rotating the low speed compression adjuster (small knob) clockwise until it stops.



-Now turn the low speed compression adjuster knob counter clock wise 20 clicks. This sets the shock at 20. (settings 21-24 are typically too soft for street use). Take the vehicle for a test drive.

-if you are satisfied with the ride quality, do not do anything, you are set!



-if the ride quality is too soft increase the damping effect by rotating the low speed compression knob clock wise 3 clicks.

#### Take the vehicle for another test drive.



-if the vehicle is too soft increase the damping effect by rotating the low speed compression knob clock wise 3 additional clicks.



-If the vehicle is too stiff rotate the low speed compression adjustment knob counter clock wise 2 clicks and you are set!

Take the vehicle for another test drive and repeat the above steps until the ride quality is satisfactory.

#### Step 3:

Adjust rebound according to Single Adjustable instructions.

#### **Note:**

**One end of the vehicle will likely reach the desired setting before the other end. If this happens stop adjusting the satisfied end and keep adjusting the unsatisfied end until the overall ride quality is satisfactory.**