



Part # 11050196

Part # 11050196 - 1958-1964 GM "B" Body Air Suspension System

Recommended Tools

Front Components:

11051013 Front CoolRide with RQ-S Series Shocks

Rear Components:

11054013 Rear CoolRide with RQ-S Series Shocks

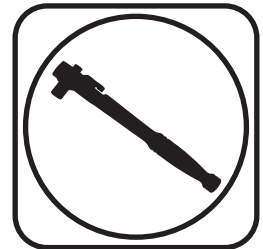

1958-1964 GM "B" Body Air Suspension Installation Instructions

Table of contents

Pages 2-8..... Front CoolRide
Pages 9-16..... Rear CoolRide

THIS COOLRIDE KIT IS DESIGNED TO BE USED WITH OEM CONTROL ARMS.





Part # 11051013

1958-1964 Full Size Chevy Car FRONT CoolRide Air Spring Kit with RQ-S Series Shocks



Recommended Tools



1958-1964 Full Size Chevy CoolRide Air Spring Kit Installation Instructions

Table of contents

- Page 3..... CoolRide Kit Components
- Page 4..... Hardware List & Getting Started
- Page 5-6..... Installing CoolRide
- Page 6-7..... Installing Shock
- Page 8..... Sway Bar End Link

THIS COOLRIDE KIT IS DESIGNED TO BE USED WITH OEM CONTROL ARMS.



CoolRide Kit ComponentsIn the box

Item #	Part Number	Description	QTY
1	90000013	Upper Air Spring Cup Bracket	2
2	90006873	8" Diameter Air Spring	2
3	90000012	Lower Air Spring Plate	2
4	90000483	Upper shock Bracket - Driver (Shown)	1
4	90000484	Upper shock Bracket - Passenger	1
5	20349999	4.75" Stud Top RQ-S Series Shock	2
6	70011138	3/4" ID Shock Bushing	2
7	90002102	1/2" ID x 1.312" Shock Sleeve	2
8	90001619	Lower Shock Bolt Kit	2
9	70011141	Stem Bushing Washer	4
10	70011140	Stem Bushing	4
	85000020	5/64" Hex Wrench - Adjuster Knob Set Screw	1

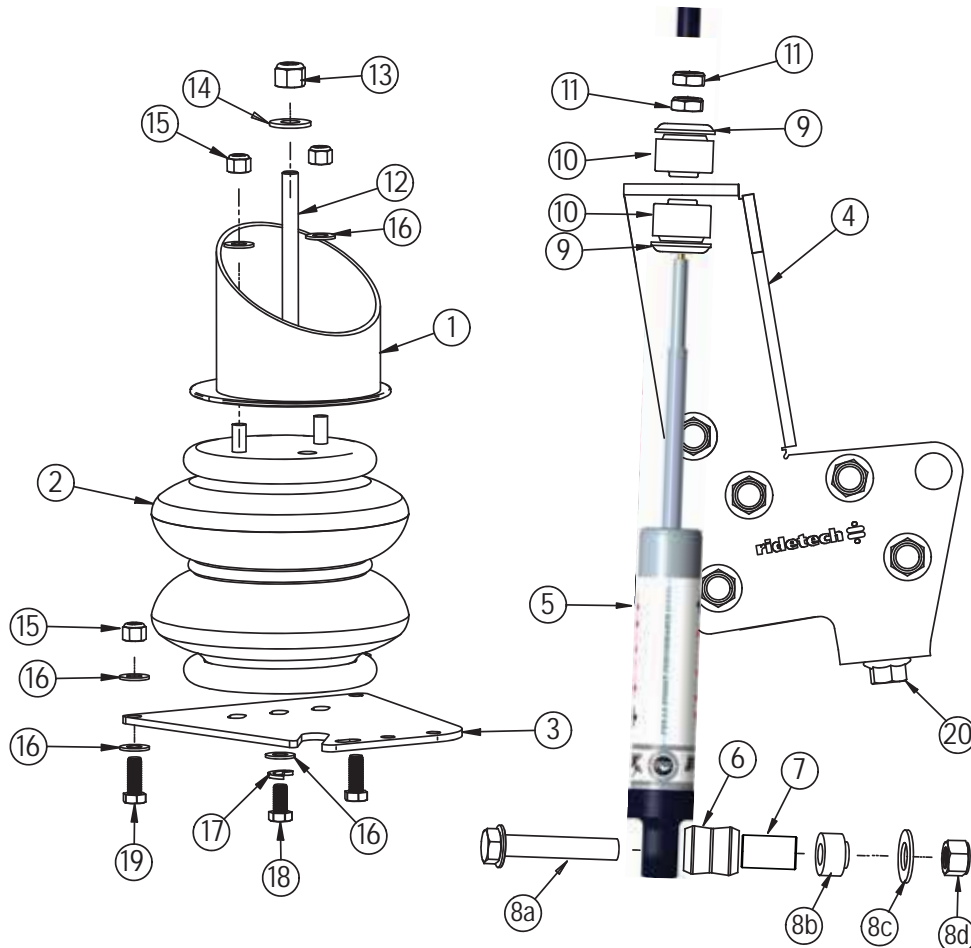



CoolRide Hardware.....In the box

Item #	Part Number	Description	QTY	Item #	Part Number	Description	QTY
UPPER SHOCK BUSHING NUTS				LOWER AIR SPRING MOUNTING			
11	99372006	3/8" 24 Thin Jam Nut	4	16	99373003	3/8" SAE Flat Washer	2
UPPER AIR SPRING MOUNTING				17	99373005	3/8" Split Lock Washer	2
12	99435002	7/16"-14 x 8" Stud	2	18	99371001	3/8"-16 X 3/4" Hex Bolt	2
13	99433002	7/16" Flat Washer	2	LOWER AIR SPRING PLATE			
14	99432001	7/16"-14 Nylok Nut	2	15	99372002	3/8"-16 Nylok Nut	4
15	99372002	3/8"-16 Nylok Nut	4	16	99373003	SAE Flat Washer	8
16	99373003	3/8" SAE Flat Washer	4	19	99371003	3/8"-16 X 1" Hex Bolt	4
SWAY BAR END LINK				SHOCK MOUNT TO FRAME			
	99371011	3/8"-16 x 6 1/2" Hex Bolt	2	20	99373007	3/8"-16 Thread Forming	12
	99372002	3/8"-16 Nylok Nut	2				

Getting Started.....

THIS KIT IS DESIGNED TO BE USED WITH RIDETECH LOWER STRONGARMS (#11051499). INSTALL THE STRONGARMS IN CONJUNCTION WITH THIS COOLRIDE KIT.

1. Raise and support car at a safe, comfortable working height. Let the front suspension hang freely
2. Remove coil spring and shock absorber. Refer to factory service manual for proper disassembly procedure.
3. Apply thread sealant to the air fitting and screw it into the top of the air spring.



4. Assemble the upper cup bracket to the air spring, using 3/8"-16 Nylok nuts and 3/8" flat washers. Torque the 3/8" nuts 15-20 ft-lbs.



Installing CoolRide

5.



5. Thread the 8" stud into the nut in the bottom of the cup.

6.



6. Install air spring assembly into the coil spring pocket with the tall side of the bracket towards the wheel. With the stud protruding through the OEM shock hole. (The airline must also be routed at this time.)

Note: Trimming the coil spring pocket is generally not necessary on this car. However, be sure to check air spring clearance through full suspension travel. Allowing the air spring to rub will result in failure and it not a warrantable situation.

7.



7. Fasten with a 7/16" Nylok nut and flat washer. Torque 25-35 ft-lbs.



Installing CoolRide & Shock



8. Bolt the lower air spring plate to the lower arm. The two outer holes will align with the factory bump stop holes. The inner two holes must be drilled. Use the bumpstop to bolt the outer part of the plate to the control arm. Use a 3/8" drill bit to drill the inner 2 holes. Install a 3/8" flat washer on each of (2) 3/8"-16 bolts and insert them into the holes. Install a 3/8" flat washer and 3/8"-16 nylok nut on the threads of the bolt. Torque to 30 ft-lbs.



9. The air spring will be attached to the lower plate using a 3/8" x 3/4" bolt, lock washer and flat washer. It will get bolted to the middle of the 3 holes. Torque the 3/8" bolt 15-20 ftlbs.



10. Position the upper shock mount on the frame so the hole in the bracket aligns with the hole in the side of the frame and the tab is against the bottom of the frame. You may have to trim some of the inner fender well for clearance. On manual shift cars you may have to trim the bottom of the Z-bar clutch bracket on the driver's side. Mark the hole in the bottom of the frame and drill with 5/16" bit. Use the 3/8" self-tapping bolts supplied and bolt the bracket to the frame. Mark and drill the remaining holes. Torque the bolts to 16 ft-lbs.



Installing Shock

11.

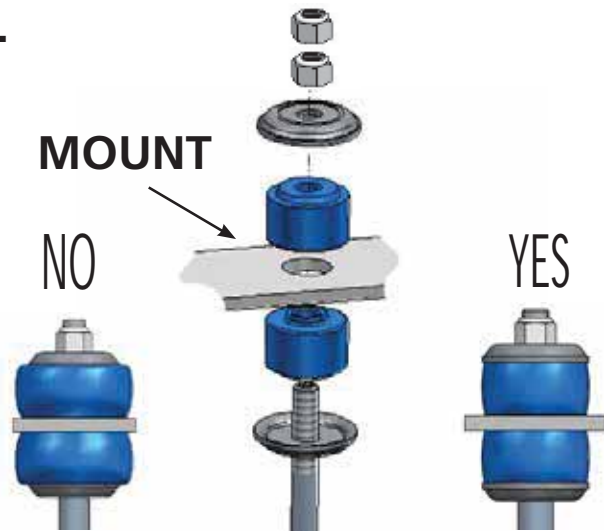

11. After the shock mounts are installed, install the Ridetech shock. Remove the adjuster knob by loosening the set screw using the supplied Hex Key. Install a Bushing Support Washer on to the shock shaft followed by a Shock Stem Bushing. Insert the assembly through the factory shock hole in the frame. With the shock stud sticking through the frame, install a Shock Stem Bushing on to the shock stud followed with a Bushing Support Washer. Install a 3/8"-24 Thin Jam nut onto the threads and tighten to 35 in-lbs. The Bushing should be tight, but not to the point that the bushing is bulging past the Support Washer. Install the 2nd 3/8"-24 Thin Jam nut and tighten it against the first nut. Reinstall the Adjuster Knob, align the set screw with the FLAT side of the adjuster shaft that is sticking out of the top of the shock shaft.

12.



12. Drill a 5/8" hole in the lower control arm approximately 7 3/4" from the cross shaft bolt.

13.

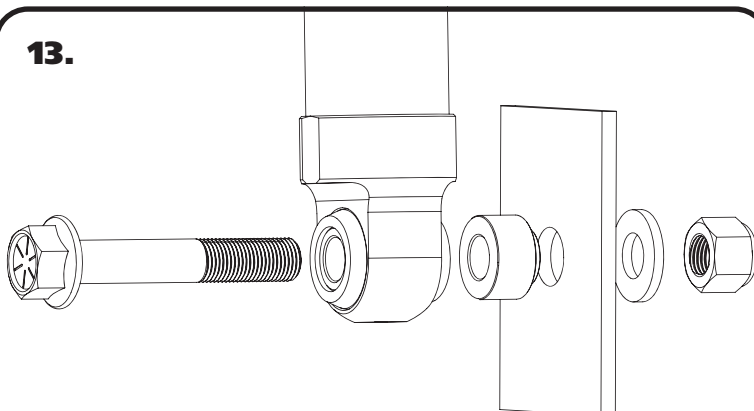

13. Insert the 1/2"-20 x 3" flanged head shock bolt through the lower shock eye and then place the aluminum spacer onto the stud. The step on the spacer will go into the arm. Slide the stud through the tab on the lower arm and secure w/ nut and washer. Torque to 75 ft-lbs.

Make sure that the air spring cannot rub on anything at anytime. This will result in air spring failure and is a not a warrantable situation.

Ride height on this air spring is approximately 5" tall, but may vary to driver preference.



Sway Bar End Link



14. To correct the sway bar alignment the end link must be shorten to 2" tall. A 3/8"-16 x 6 1/2" bolt is supplied.



Part # 11054013

1958-1964 Full Size Chevy Car REAR CoolRide AirSpring Kit with RQ-S Series Shocks



Recommended Tools

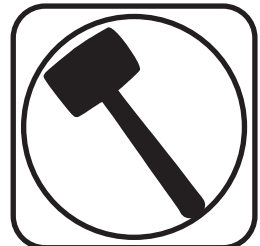

1958-1964 Full Size Chevy CoolRide AirSpring Kit Installation Instructions

Table of contents

- Page 10..... CoolRide Kit Components
- Page 11..... Hardware List & Getting Started
- Page 12-14.... Installing CoolRide
- Page 15-16.... Shock Adjustment

THIS COOLRIDE KIT IS DESIGNED TO BE USED WITH OEM CONTROL ARMS.



CoolRide Kit ComponentsIn the box

Item #	Part Number	Description	QTY
1	90000463	Upper Air Spring Cup Bracket - Driver (<i>Shown</i>)	1
1	90000464	Upper Air Spring Cup Bracket - Passenger	1
2	90006873	8" Diameter AirSpring	2
3	90000465	Lower Air Spring Bracket	2
4	90000472	Bump Stop Spacer	2
5	70013322	Short Bump Stop	2
6	20489999	7.55" RQ-S Series Shock Assembly	2
7	90002103	5/8" ID x 1.312" Shock Sleeve	2
8	90002068	Extended Trunnion	2
9	70011138	3/4" ID Shock Bushing	2
10	70011139	5/8" ID Shock Bushing	2

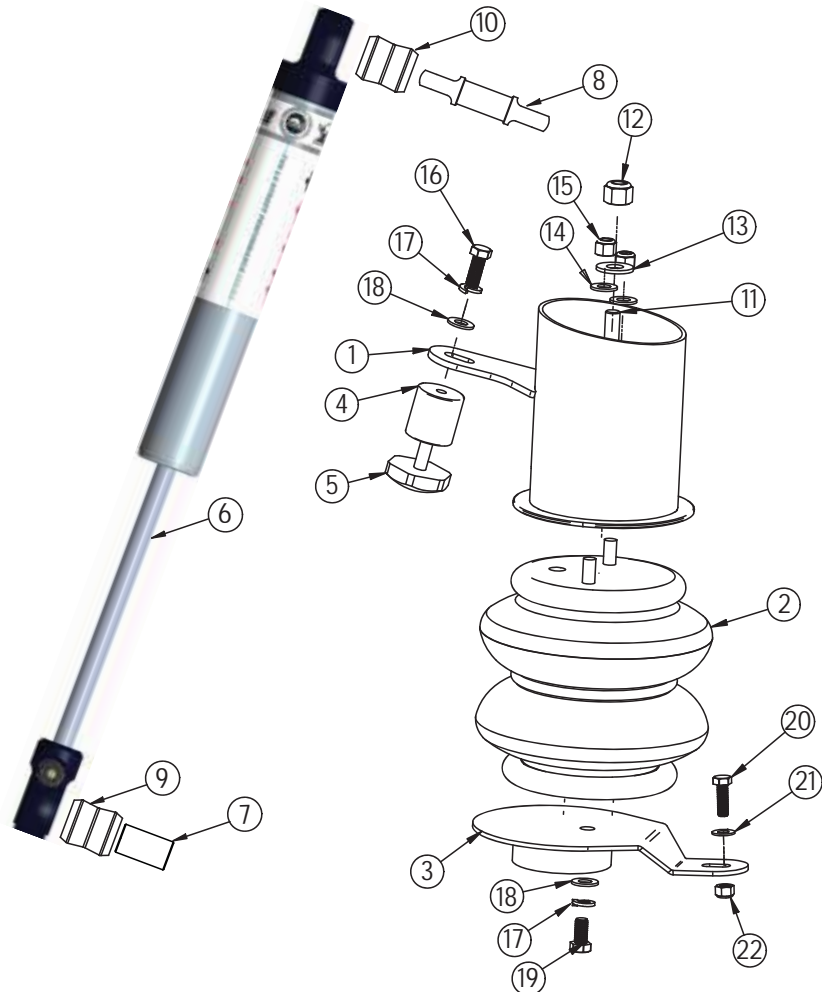



CoolRide Hardware Kit #99010105.....In the box

Item #	Part Number	Description	QTY	Item #	Part Number	Description	QTY
UPPER AIR SPRING MOUNTING				LOWER AIR SPRING MOUNTING			
11	99435001	7/16"-14 x 6" Stud	2	20	99311001	5/16"-18 X 1" Hex Bolt	2
12	99432001	7/16"-14 Nylok Nut	2	21	99313002	5/16" SAE Flat Washer	4
13	99433002	7/16" Flat Washer	2	22	99312003	5/16" Flat Washer	2
14	99372002	3/8"-16 Nylok Nut	4	SHOCK HARDWARE			
15	99373003	SAE Flat Washer	4		99311001	5/16"-18 X 1" Hex Bolt	4
BUMP STOP MOUNTING					99312003	5/16"-18 Nylok Nut	4
16	99371003	3/8"-16 X 1" Hex Bolt	2		99313002	5/16" SAE Flat Washer	8
17	99373005	3/8" Split Lock Washer	2		99502002	1/2"-20 Nylok Nut	2
18	99373003	3/8" SAE Flat Washer	2		99503001	1/2" SAE Flat Washer	2
LOWER AIR SPRING MOUNTING							
17	99373005	3/8" Split Lock Washer	2				
18	99373003	3/8" SAE Flat Washer	2				
19	99371001	3/8"-16 X 3/4" Hex Bolt	2				

Getting Started.....

THIS KIT IS DESIGNED TO BE USED WITH OEM LOWER CONTROL ARMS.

1. Raise and support vehicle at a safe and comfortable working height.
2. Support axle then remove coil spring, shock, and bump stop. Refer to service manual for proper disassembly procedure.
3. Apply thread sealant to the air fitting and screw it into the top of the air spring.

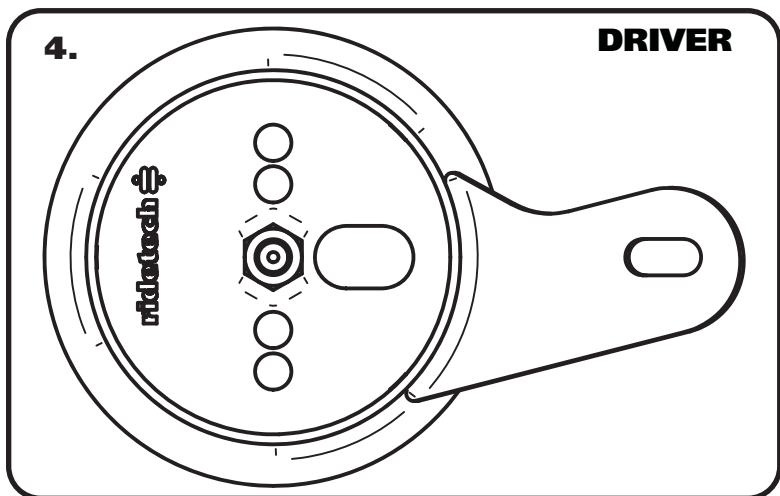

4. This is the driver bracket looking down at the top of it.

The tab goes to the rear of the car.



Installing CoolRide



3. Apply thread sealant to the air fitting and screw it into the air spring. Assemble the upper cup bracket to the air spring, using 3/8" - 16 Nylok nuts and 3/8" flat washers. Torque the 3/8" nuts 15-20 ft-lbs.



4. Thread the 6" stud into the nut in the bottom of the cup.



5. Place the air spring assembly into the coil spring pocket with the tab on the side of the cup aligning with the factory bump stop mount. The stud should poke through the hole in the upper coil spring pocket. Some cars may not have this hole and it must be drilled with a 7/16" drill bit. Fasten with a 7/16" Nylok nut and flat washer. Torque 25-35 ft-lbs.



Installing CoolRide



6. Fasten the aluminum bump stop spacer to the frame using a 3/8" x 1" bolt, flat washer and lock washer. Torque to 15 ft-lbs. Screw the bump stop into the spacer.



7. Bolt the lower mount to the bottom of the air spring using a 3/8" x 3/4" bolt, lock washer and flat washer. Before tightening, make sure it aligns with the lower arm. The hole in the tab on the lower mount will align with the parking brake cable clamp. It will be held tight with a 5/16" x 1" bolt, and flat washer. A second flat washer and nylok nut are supplied with the kit incase the threads of your control arm are damaged. Torque the 3/8" bolt 15-20 ft-lbs. Torque the 5/16" bolt to 9 ft-lbs.



8. Attach shock T-Bar to frame using 5/16" x 1" bolts, Nylok nuts and flat washers. Torque to 17 ft-lbs.



Installing CoolRide



9. Attach the bottom of the shock to factory shock stud using the 1/2" Nylok nut & flat washer supplied. Torque the nut to 45 ft-lbs.

Make sure that the air spring cannot rub on anything at anytime. This will result in air spring failure and is a not a warrantable situation.

Ride height on this air spring is approximately 5" tall, but may vary to driver preference.



TUNING GUIDE

SINGLE-ADJUSTABLE SHOCKS



The Basics...

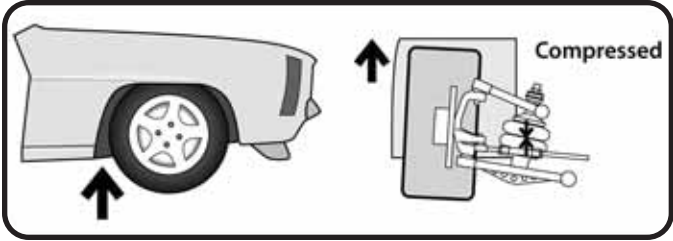

COMPRESSION

This typically occurs when you hit a bump in the road. The bump forces the wheel/tire/suspension assembly to "compress" or move upwards into the car.

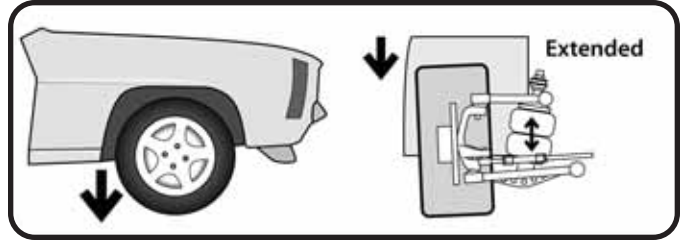

REBOUND

Rebound is the opposite of compression. This occurs when the wheel/tire/suspension assembly falls into a pothole, or simply "rebounds" from being compressed.

Where Are The Knobs?

RQ-S Series Shocks

- The adjustment knob is located on the top of the shock, either protruding from the side of the eyelet, or atop the stud.
- This knob provides rebound adjustment only.

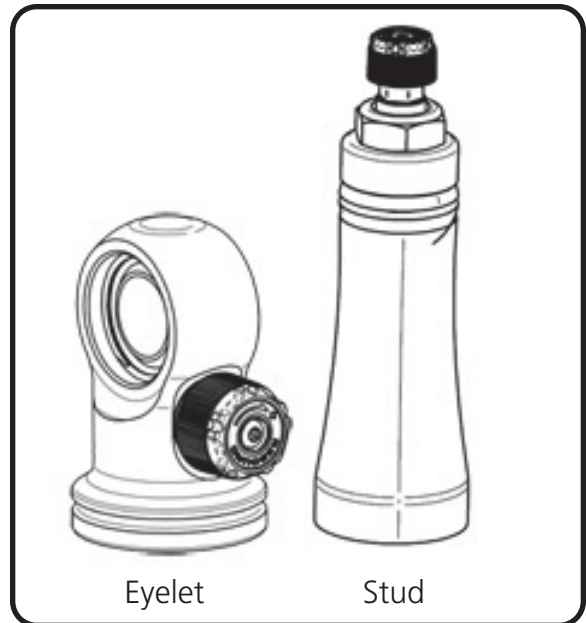

Knob Function

Counterclockwise

=
Softer

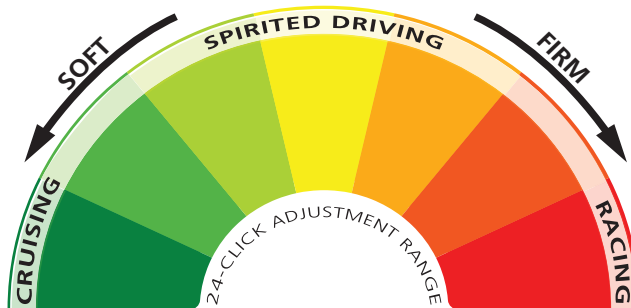

Clockwise

=
Firmer





TUNING GUIDE

SINGLE-ADJUSTABLE SHOCKS



Initial Rebound Setting

NOTE: Before jumping straight to a middle-of-the-road shock setting, we recommend you experience the full range of adjustment potential of your new shocks by first driving your vehicle at both the “full stiff” and “full soft” settings. Understanding how your shocks behave at these extremes will provide recognizable reference points as you attempt to dial in your settings.

1. Begin by setting your shocks to the “full stiff”, or minimal rebound position. You do this by turning the adjustment knob clockwise until it stops.

2. Now turn the adjustment knob counterclockwise 12 clicks. This is the approximate center of the adjustment range.

3. Take the vehicle for a test drive. Try to determine if you are experiencing any of the unwanted behaviors found at the extremes of the adjustment range. If you are satisfied with the ride quality and handling, you’re all set. Enjoy the ride!

4. If the vehicle feels too “floaty” or soft, turn the knob a few clicks clockwise to increase the damping effect.

If the ride quality is still too harsh or stiff, turn the knob a few more clicks counterclockwise to decrease the damping effect.

5. Take the vehicle for another test drive. If necessary, repeat the steps above until your desired optimal ride quality has been achieved.



General Guidelines

- The rear shocks typically have the most influence on ride quality. This is due to your seating position being closer to the rear than the front.
- Adjustments to the front shocks will generally require 3-4 clicks in any direction to be noticeable, while adjustments to the rear shocks may only require 1-2 clicks to be felt.
- Don’t be afraid to turn the knobs and experience the full adjustment range. You are not going to hurt anything and you can always go back if you adjust too far one way or the other.