



Part # 11051499

1958-1964 GM B-Body Front Lower CoolRide StrongArms



Recommended Tools



1958-1964 GM B-Body Lower StrongArms Installation Instructions

Table of contents

- Page 2..... Lower Control Arm Components
- Page 3..... Getting Started & Installation
- Page 4..... Installation
- Page 5..... Installing Spindle and Alignment

THESE CONTROL ARMS ARE DESIGNED TO BE USED WITH THE 1959-1964 **OEM** SPINDLES.





Upper Control Arm ComponentsIn the box

Item #	Part Number	Description	QTY
1	90001302	Driver Lower Control Arm (Shown)	1
1	90001303	Passenger Lower Control Arm	1
2	90002586	Lower Ball Joint Kit - only available through Ridetech	2
3	90000676	Lower Cross Shaft	2
4	90000677	Lower Cross Shaft Clamp	2
5	70014457	Delrin Bushings	4
6	90001289	Bushing Inner Sleeve	4
7	99250001	Grease Zerk	2
8	70014361	Steering Stop - Driver (Shown)	1
8	70014362	Steering Stop - Passenger	1

HARDWARE LIST IS ON PAGE 3

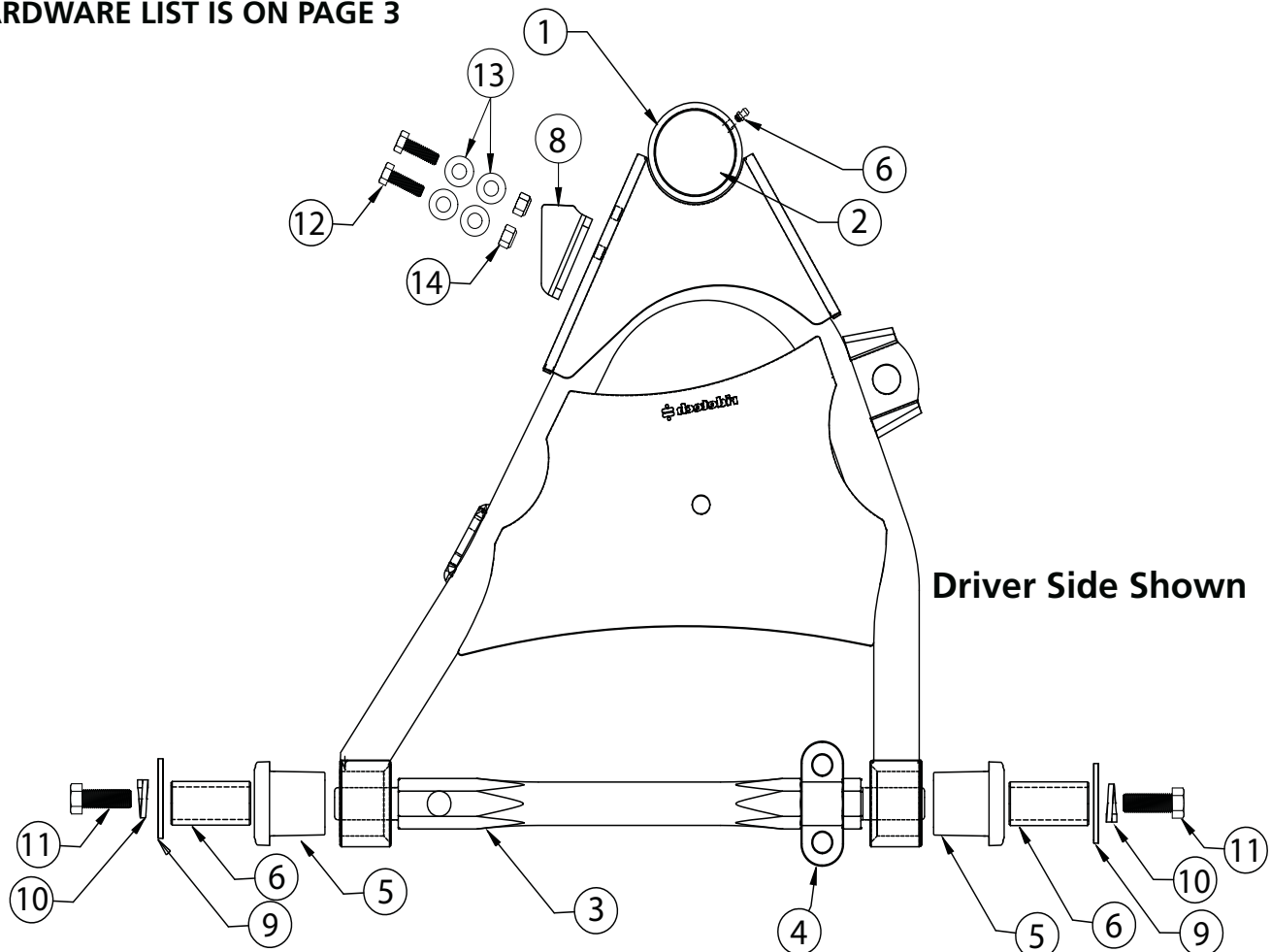



Hardware ListIn the box (Kit# 99010091)

The Hardware Kit contains bags to help aid in selecting the correct hardware for the component being installed. The hardware list shows how the hardware is bagged.

Item #	QTY	Part Number	Description	Use
CONTROL ARM BUSHING HARDWARE				
9	4	99433001	7/16" Flat Washer	Control Arm Bushing Hardware
10	4	99433003	7/16" Split Lock Washer	Control Arm Bushing Hardware
11	4	99431006	7/16"-20 x 1 1/4" Hex Bolt	Control Arm Bushing Hardware
STEERING STOP TO CONTROL ARM				
12	4	99311030	5/16"-18 x 1" Hex Bolt	Steering Stop to Control Arm
13	8	99313001	5/16" Flat Washer	Steering Stop to Control Arm
14	4	99312003	5/16"-18 Nylok Nut	Steering Stop to Control Arm
THE FOLLOWING HARDWARE IS NOT SHOWN IN THE DIAGRAM				
CROSS SHAFT TO FRAME				
	4	99431015	7/16"-20 x 2 1/4" Hex Bolt	Cross Shaft Clamp to Frame
	4	99433003	7/16" Split Lock Washer	Cross Shaft Clamp to Frame
	2	99561001	9/16"-18 x 2 1/2" Hex Bolt	Cross Shaft to Frame
	2	9956603	9/16" SAE Flat Washer	Cross Shaft to Frame
	2	99562001	9/16"-18 Nylok Nut	Cross Shaft to Frame

Getting Started.....

Congratulations on your purchase of the Ridetech 58-64 B-Body StrongArms. These StrongArms have been designed to give your B-Body excellent handling along with a lifetime of enjoyment. Some of the key features of the StrongArms: Ball joint angles have been optimized for the lowered ride height, Delrin bushings are used to eliminate bushing deflection along with providing free suspension movement through the entire travel. The Delrin bushings are made from a material that is self lubricating so no grease zerks are needed.

1. Remove the lower control arms from the car. If you are replacing the upper control arms and spindle, remove them too. Refer to a Factory Service Manual for the proper method.



Installation

2.

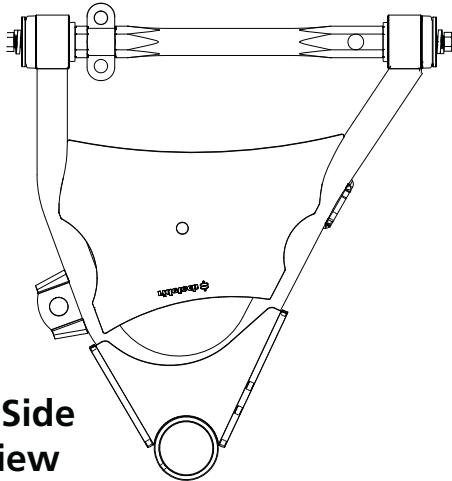

Driver Side
Top View

2. The Lower Control Arm is attaching the frame using the included hardware. The driver side arm is shown in **Figure "2"**. The sway bar mount is located to the front of the car.

Install the CoolRide & Hq Series Shock Kits at this time. Refer to each kits instructions for assembly.

3.



3. The Aluminum Clamp is installed in the notch machined in the lower cross shaft. Install a 7/16" Split Lock Washer on each of (2) 7/16"-20 x 2" Hex Bolts. Install a 9/16" Flat Washer on a 9/16"-18 x 2 1/2" Hex Bolt. Hold the control arm in-place with the holes aligned with the holes in the frame. Insert the 7/16" bolts in the holes of the cross shaft clamp and thread them into the OEM nut plate that is in the frame. Insert the 9/16" bolt/washer in the rear hole of the cross shaft and through the frame. Install a 9/16"-18 Nylok Nut on the threads of the bolt that are sticking through the frame. Torque the 7/16" hardware to 55 ftlbs. Torque the 9/16" hardware to 120 ftlbs.

4.



4. Attach the shock to the lower control arm, refer to the shock kit instructions. Also, attach the airspring to the lower control arm using the hardware supplied with the CoolRide kit.



Installing Spindle and Alignment



5. Attach the Spindle to the control arms. These control arms use a tall ball joint, the boot will NOT touch the spindle. This is normal.

Torque Specs:

Ball joint - 45 ftlbs and tighten to line up cotter pin.

Install the Cotter Pin after tightening the ball joint nut.



6. Attach the adjustable steering stop to the lower arm using (2) 5/16" x 1" bolts, (4) 5/16" flat washers, & (2) 5/16"-18 nylok nuts.. This can be adjusted to maintain tire/shock clearances. Torque the steering stop hardware to 25 ftlbs.

7. Tighten all fasteners and grease the ball joints. Connect the sway bar linkage to the new StrongArms. If you are going to install the Ridetech MuscleBar, now is a good time to do it.

Suggested Alignment Specs:

Camber:	Street: -.5 degrees
Caster:	Street: +3.0 to + 5.0 degrees
Toe:	Street: 1/16" to 1/8" toe in