

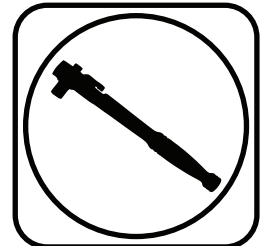

### Part # 11055010/11055110 - 1958-1964 GM B-Body StreetGrip

<b>Front Components</b>	
11059590	Delrin Control Arm Bushings
90003041	Tall Upper Ball Joint
11052350/11052351	Front Dual Rate CoilSprings
22169847	Front HQ Series Shocks
11059120	Front Sway Bar
11059300	Drop Spindle
<b>Rear Components</b>	
11054798	Rear Dual Rate CoilSprings
22189844	Rear HQ Series Shocks
11059122	Rear Sway Bar

#### Recommended Tools



# 1958-1964 GM B-Body Street Grip Installation Instructions

<b>Table of contents</b>	
Page 2.....	Major Components and Hardware List
Page 3.....	Getting Started
Page 4-6.....	Delrin Bushings
Page 7-8.....	Tall Upper Ball Joint
Page 9.....	Front Dual Rate CoilSpring
Page 10-13.....	Front Sway Bar
Page 14.....	Rear Dual Rate CoilSpring
Page 15-18.....	Front and Rear HQ Series Shocks
Page 19-21.....	Rear Sway Bar

The Spindle in this kit is a Classic Performance Products(CPP) disc brake spindle. Most brake companies offer a disc brake package for this spindle.



### Major Components .....In the box

Part #	Description	QTY
55585950/55585951	Front CoilSprings - Small Block/Big Block	2
55545950	Rear CoilSprings	2
90003041	Tall Upper Ball Joint	2
90003077	Lower Ball Joint	2
90002514	Delrin Bushing Outer Shell - Upper Control Arm	4
90002537	Delrin Bushing Outer Shell - Lower Control Arm	4
90002521	Delrin Bushing Inner Sleeve - Upper Control Arm	4
90002538	Delrin Bushing Inner Sleeve - Lower Control Arm	4
70012395	Delrin Bushing - Upper Control Arm	4
70012506	Delrin Bushing - Lower Control Arm	4
	<b>Front Shocks</b>	
986-10-044	5.75" Stroke Stud Top Shock	2
70011139	5/8" ID Shock Bushing (Installed in Shock)	2
90002068	Standard T-Bar (Installed in Shock)	2
70011140	Stud Top Bushing	4
70011141	Stud Top Bushing Washer	4
99372006	3/8"-24 Jam Nut	4
	<b>Rear Shocks</b>	
986-10-020	7.55" Stroke Eye Top Shock	2
70011139	5/8" ID Shock Bushing (Installed in Shock)	2
70011138	3/4" ID Shock Bushing (Installed in Shock)	2
90002068	Wide T-Bar (Installed in Shock)	2
90002103	5/8" ID Shock Sleeve (Installed in Shock)	2
11059120	Front Swaybar Kit	1
11059122	Rear Swaybar Kit	1
11059300	2" Drop Spindle	1
99373005	3/8" Split Lock Washer	4
99433003	7/16" Split Lock Washer	4
90002263	Red Loctite	1



## Getting Started.....

Congratulations on your purchase of the Ridetech StreetGrip Kit. This system has been designed to give your Car excellent ride and handling along with a lifetime of enjoyment. Some of the key features of this Kit: Dual Rate CoilSprings, Delrin Control Arm Bushings, Larger Sway Bars with Delrin Liners and a Taller Upper Ball Joint.

The majority of the StreetGrip Components will be installed together. For example, the Front CoilSprings, Ball Joint, Control Arm Bushings, Spindles, and Shocks will be installed in conjunction with each other. On the rear, the CoilSprings and Shocks will be installed in conjunction with each other. The Sway Bars will, typically, be installed after the rest of the components are installed.

## Hardware Kit .....#99010064

The StreetGrip Kit is supplied with a hardware kit. This hardware kit contains individual bags for the different kits within the main kit. The bags are labeled to help determine the correct hardware for the installation of the specific kits. The instructions will aid you in selecting the correct hardware for each component. The bags included in this kit are:

- Front Sway Bar Kit
- Control Arm Kit
- Rear Sway Bar Kit

## Front Suspension

The front components that will need to be installed are: Control Arm Bushings, Upper Ball Joints, Shocks, Spindles, and CoilSprings. The Sway Bar can be installed anytime after the rest of the front suspension is complete.

If you have never done this type of work before, we recommend getting a Factory Service Manual for proper procedures of disassembly and reassembly of the components for your car.

## Rear Suspension

The rear components that will be installed are; rear Dual Rate CoilSprings, and rear HQ Series Shocks. The Swaybar can be installed after the rest of the suspension is assembled.

## Alignment Specs

Anytime you change suspension components, you should have the car alignment checked.

### Suggested Alignment Specs:

- Camber: Street: -.5 degrees
- Caster: Street: +3.0 to + 5.0 degrees
- Toe: Street: 1/16" to 1/8" toe in



**Part # 11059590 - 1958-1954 B-Body Delrin Control Arm Bushings**



Recommended Tools

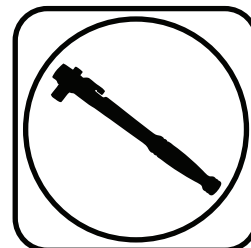

## 1958-1964 B-Body Delrin Control Arm Bushings

# Installation Instructions

Table of contents

Page 5..... Included Components and Hardware List

Page 6..... Bushing Installation



### Major Components .....In the box

Part #	Description	QTY
70012382	Upper Control Arm Bushing Outer Shell	4
70012517	Lower Control Arm Bushing Outer Shell	4
70012419	Delrin Upper Control Arm Bushing	4
70012572	Delrin Lower Control Arm Bushing	4
90002521	Upper Bushing Inner Sleeve	4
90002538	Lower Bushing Inner Sleeve	4
70012573	Cross Shaft Alignment Spacer - .750" - Rear Alignment Spacer	2
70012574	Cross Shaft Alignment Spacer - .250" - Front Alignment Spacer	2

#### Hardware Bag - Control Arm Kit

Part #	Description	Usage	QTY
99433003	7/16" Split Lock Washer	Lower Control Arm Shaft Bolts	4
99373005	3/8" Split Lock Washer	Upper Control Arm Shaft Bolts	4
90002263	Red Loctite	Control Arm Shaft Bolts	1
99431017	7/16"-20 x 2 3/4" Hex Bolt	Upper Cross Shaft to Frame	4
99432008	7/16"-20 Locking Nut	Upper Cross Shaft to Frame	4

### Getting Started.....

The Front Control Arms will need to be removed from the car. Refer to the Factory Service Manual for disassembly procedure.

This B-Body Bushing Kit contains: 4 Upper Control Arm Bushing Assemblies and 4 Lower Control Arm Bushing Assemblies. The Upper Bushings are all the same and the Lower Bushings are the same. Be sure to match the correct Bushings with the correct locations.

**THE UPPER CONTROL ARM REQUIRES SPACERS TO BE RAN BETWEEN THE CROSS SHAFT AND THE FRAME. THE FRONT REQUIRES A 1/4" SPACER, THE REAR REQUIRES A 3/4" SPACER. THE SPACERS AND LONGER 7/16" X 2 3/4" BOLTS ARE SUPPLIED IN THIS KIT.**

There are several different ways that the Bushings can be removed from the Control Arms. If you have an Air Chisel, a Wide Flat Bit works well. If you don't have access to an Air Chisel, they can be removed by first, drilling out the rubber with a Hand Drill and Drill Bit. With the Rubber removed, distort the Bushing Shell with a Hammer and Chisel and Knock it out. No matter the process used, the main objective is to **NOT** distort the Control Arm.

**WE RECOMMEND MARKING DRIVER AND PASSENGER CONTROL ARMS AND CROSS SHAFTS. ALSO, MARK THE ORIENTATION OF THE CROSS SHAFTS.**

1. Measure the Outside Width of the Control Arms and write it down before starting Bushing Removal. You will use this Dimension to check the Control Arms after the new Delrin Bushings are installed.



### Delrin Bushing Installation

The Cross Shaft must be put in place and in the correct orientation before installing the Bushing Shells in the Upper & Lower Control Arms.

Just like Bushing Removal, there are several ways the Delrin Bushing Assemblies can be installed. No matter the method used, the Control Arm needs to be **SUPPORTED** to keep from distorting the Control Arm. We recommend cutting spacers to go inside the Control Arms when using a Press to install the Bushings. We have used several different methods to install the Bushing Assemblies. We are going to cover the one that worked best for us. When installing the Bushings, the Outer Shell will be installed in the Arm by itself. Next, Press in the Delrin Bushing, followed by the Inner Sleeve. **WE DO NOT RECOMMEND INSTALLING THE BUSHINGS COMPLETELY ASSEMBLED.**

**Note:** The Delrin is self-lubricating, no lubricant is needed.

**2. Disassemble the Bushing being installed. When installing Bushings in the Control Arms, insert the Cross Shaft before installing any Bushings.** Support the Back Side of the Flange the Bushing is being Installed in. Use a STIFF piece of Metal clamped in a Bench Vise for the Lower Control Arms (**Figure 2**). The Upper Control Arm can be supported by either the same piece of Metal or by the Bench Vise with the Jaws opened wide enough to let the Bushing Shell pass through (**Figure 3**).

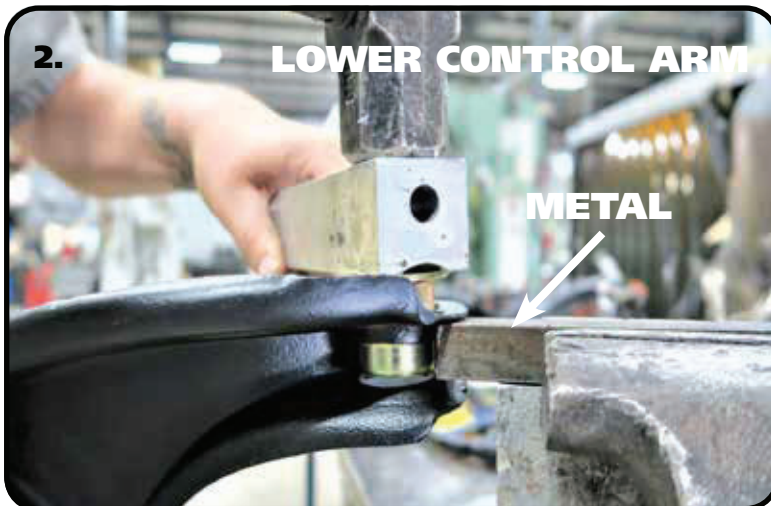

**3.** Use another Piece of Metal or Strong Wood to Drive the Outer Shell into the Control Arm until the Shell stops against the Control Arm.

**4.** Press the Delrin Bushing into the Bushing Shell followed by the Inner Sleeve. DO NOT DRIVE IN WITH HAMMER.

**5.** Reinstall the Outer Washer using the OEM Bolt, but replace the Lock Washer with the supplied Lock Washer and apply Loctite to the threads. Tighten Hardware to eliminate any gaps between the Bushings and Cross Shaft.

**6.** Reattach the Lower Control Arm. to Car using the OEM Hardware. .



**The Upper Control Arm requires spacers to be ran on the attaching bolts. The kit includes a 1/4" Aluminum Spacer for each front bolt and a 3/4" Aluminum Spacer for each rear bolt. It is necessary to run these spacers.**

**7.** To attach the Upper Control Arm, you will need to knock the OEM bolts out of the frame and replace them with the 7/16" x 2 3/4" Bolts supplied with the kit. Insert the new bolts into the mounting holes and install the 1/4" Spacer in the Front Bolt and the 3/4" Spacer on the Rear Bolt then install the control arm. Install the 7/16" Lock Nuts and tighten.



### Part # 90003041 - B-Body Tall Upper Ball Joint



#### Recommended Tools

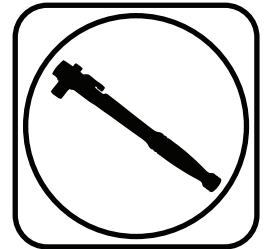

## B-Body Tall Upper Ball Joint Installation Instructions

Table of contents
Page 8..... Included Component & Ball Joint Installation

DUE TO THE SHANK OF THE BALL JOINT BEING LONGER, THE BALL JOINT BOOT IS DESIGNED TO SEAL ON THE BALL JOINT SHANK. IT DOES NOT SEAL AGAINST THE SPINDLE.



### Major Components .....In the box

Part #	Description	QTY
90003041	B-Body Tall Upper Ball Joint	2
90003077	Lower Ball Joint	2

### Getting Started.....

The Tall Upper Ball Joint is used in the StreetGrip Kit to help correct the camber gain. The Camber Gain on the OEM Suspension is incorrect and the Tall Ball Joint repositions the upper control arms to help improve the camber gain.

**The Upper Ball Joint will need to be disconnected from the Spindle. Refer to the Factory Service Manual for Disassembly.**



**1.** If your Ball Joints are Bolted to the Control Arms, simply unbolt them. If your car has the Original Ball Joints, they will be Riveted to the Control Arms. The Rivets can be removed by Grinding the Heads off and driving the out with a Hammer and Punch.

**NOTE: WE RECOMMEND MARKING THE DRIVER AND PASSENGER CONTROL ARMS.**



**2.** Insert the Ball Joint into the Control Arm from the top side of the Control Arm with the Ball Joint Pin Sticking down. Attach it to the Control Arm with the Hardware Supplied with the Ball Joint. Torque the Hardware to 25 ftlbs. Engage the Ball Joint Pin into the Spindle and install the Castle Nut Supplied. Torque the Castle Nut to 50 ftlbs and tighten to align Cotter Pin Hole. Install Cotter Pin through Hole and Bend Pins to prevent falling out.

**3.** Remove the lower ball Joint and replace it with the new ball Joint supplied in the kit.





**Part # 11052350/11052351 - 1958-1964 B-Body Front CoilSpring**



### Recommended Tools

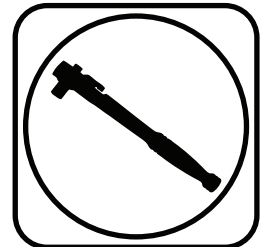

## 1958-1964 B-Body Front CoilSprings Installation Instructions

**CoilSpring # 55585950** Small Block /**55585951** Big Block **Installation**

Front dual-rate coilsprings will allow the vehicle to transition small road irregularities via a soft spring rate. When the vehicle compresses the spring far enough (through large bumps or cornering), it transitions to the firmer spring rate to control the bump or body roll. We have worked closely with Hyperco to develop custom dual rates to ensure the best ride possible.

**The Front Control Arm Bushings and Upper Ball Joint should be installed before installing spring. The Front Suspension should be assembled with the Lower Ball Joint disconnected from the Spindle.**

1. Compress the CoilSpring with an Internal Spring Compressor with the **CLOSE COILS TO THE BOTTOM**.
2. With the OEM Spring Removed, insert the CoilSpring into the Pocket. **SPECIAL ATTENTION NEEDS TO BE PLACED ON THE LOCATION OF THE ENDS OF THE SPRINGS TO MAKE SURE THEY ARE CLOKED CORRECTLY** . The end of the CoilSpring will nest into the receiver area of the Control Arm. If you line up the bottom, the top will be correct.
3. While holding the Spring in place, Slowly Jack the Lower Control Arm up until the Lower Ball Joint can be Engaged into the Spindle. Install the Castle Nut and Torque to 65 ftlbs then tighten as needed to align cotter pin hole. Install Cotter Pin. Once the Ball Joint is tight, remove the Spring Compressor.





### Part # 11059120 - 1958-1964 Chevrolet B-Body Front Sway Bar



#### Recommended Tools

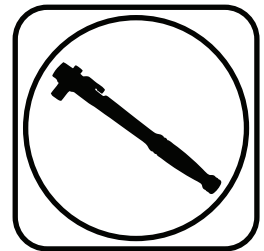

## 1958-1964 Chevrolet B-Body Front Sway Bar Installation Instructions

#### Table of contents

- Page 11..... Included Components and Hardware List
- Page 11-13..... Sway Bar Installation

IF YOUR CAR HAS THE FACTORY POWER STEERING SLAVE CYLINDER, KIT 11059121 WILL BE NEEDED TO INSTALL THE STREETGRIP SWAYBAR

#### Hardware Torque Specifications

- 5/16"-16..... 17 ftlbs
- 3/8"-16..... 30 ftlbs

# Major Components .....In the box

Part #	Description	QTY
90001352	Front Sway Bar	1
90002937	End Link Kit	1
90002533	Bushing Strap	2
70015013	Lined Sway Bar Bushing	2
90002534	Bushing and Strap Spacer	4

## HARDWARE

QTY	Part Number	Description
4	99311002	5/16"-18 x 1 1/4" Hex Bolt
4	99311003	5/16"-18 x 1 1/2" Hex Bolt
8	99313002	5/16" Flat Washer
4	99372003	5/16"-18 Nylok Nut

## Getting Started.....

**Note:** This sway bar kit utilizes a anti-friction lining in the sway bar bushing. The lining allows the sway bar to move freely and quietly in the bushing. No lubrication is required.

- 1. Jack the vehicle up to a safe working height and support with jack stands. Make sure the jack stands are stable before working under the car.**
2. Remove the stock sway bar.
3. Due to the larger diameter of your new swaybar, the Idler Arm will need to be disconnected from the frame to install the new sway bar.



**NOTE: IF YOUR CAR HAS THE FACTORY POWER STEERING SLAVE CYLINDER, KIT 11059121 WILL BE NEEDED TO INSTALL THE STREETGRIP SWAYBAR**

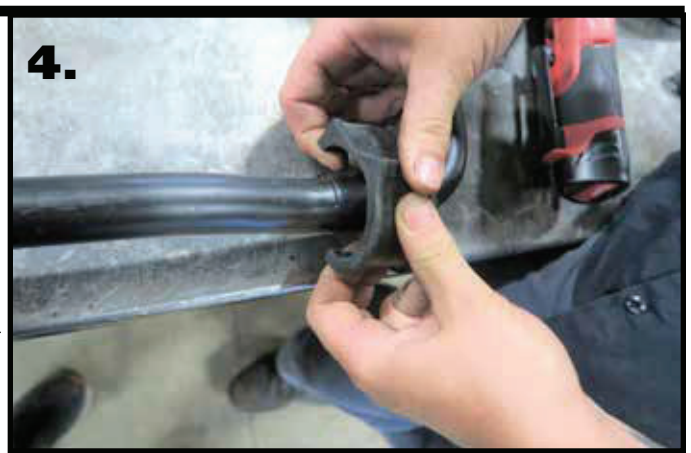

**4.** Open the sway bar bushing at the split and slip it **OVER** the sway bar. Do this for both bushings

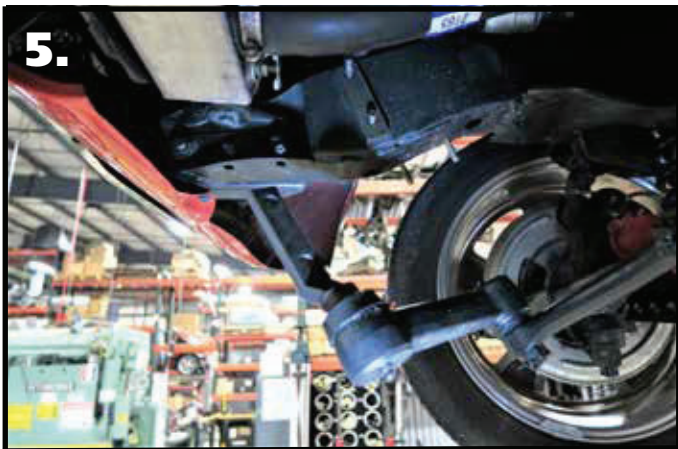

**5.**

5. Disconnect the idler arms from the frame.

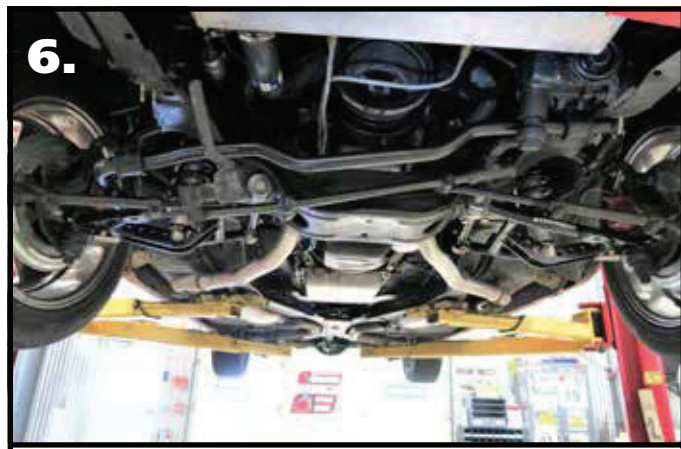

**6.**

6. Insert the new swaybar from the passenger side. position it above the idler arm and steering arm. the center of the bar should hang down towards the ground.



**7.**

7. Install a 5/16" flat washer on each of (2) 5/16"-18 x 1 1/4" bolts and insert them into the OEM sway bar holes by inserting them in through the access holes in the side of the frame. Install the spacer plate with the wide side positioned to the inside. Hold it in place.



**8.**

8. Install the bushing strap over the swaybar bushing with the wide side of the strap to the inside on the car. We found some steering box conversions hang down further than others. If yours happens to hit the sway bar, add a 2nd spacer under the bushing. a 2nd set of spacers along with longer hardware is supplied in this kit.



**9.**

9. Lift the bar in position, the bolts sticking through the frame and spacer will go in the slots of the bushing strap. Hold the bar in place & install a 5/16" flat washer and 5/16"-18 nylok nut on the threads of each bolt sticking through the slots of the bushing strap. Repeat steps 8-10 on the opposite side, but do not tighten the hardware at this time.



**10.**

10. Reattach the idler arm to the frame using the OEM hardware. Torque the hardware.

**11.**



**11.** Install the End Links using **Diagram 1** as a reference. Install both end links before tightening the end link hardware. Tighten the end link barrel nut until it is flush with the end of the bolt, and then tighten it 2 more complete rounds.

**12.** Torque the SwayBar mounting hardware to 17 ftlbs.

**Diagram 1**

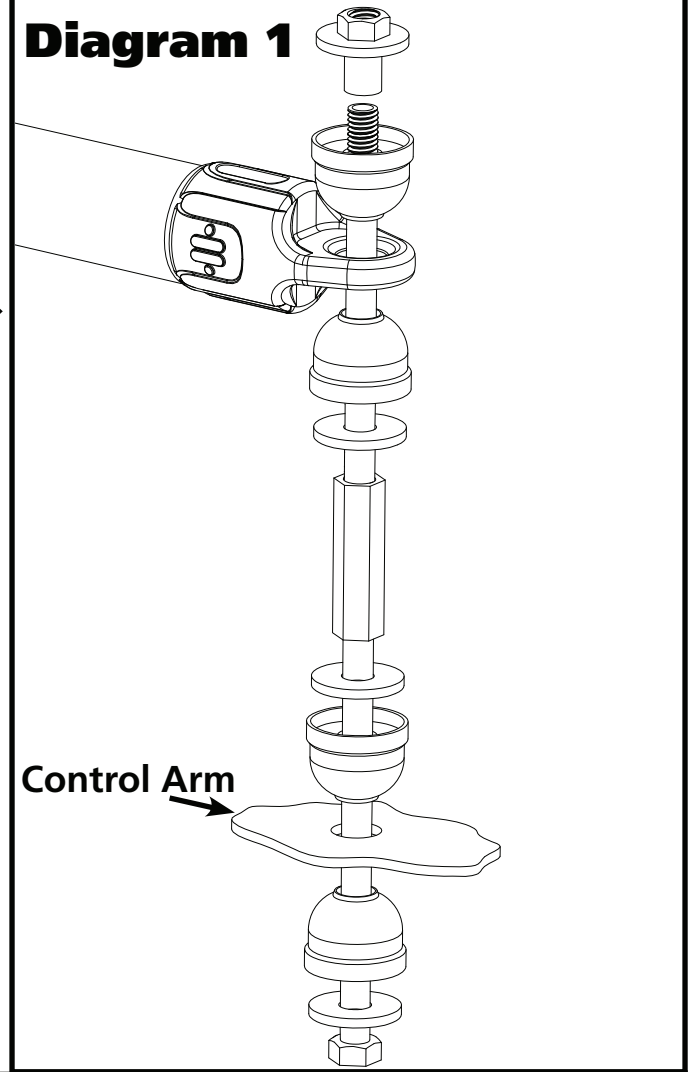

**Control Arm**



### Part # 11054798 - 1958-1964 B-Body Rear CoilSpring



#### Recommended Tools

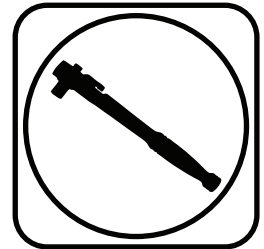

## 1958-1964 B-Body Rear CoilSprings Installation Instructions

### CoilSpring # 55545950 Installation

Rear dual-rate CoilSprings will allow the vehicle to transition small road irregularities via a soft spring rate. When the vehicle compresses the spring far enough (through large bumps or cornering), it transitions to the firmer spring rate to control the bump or body roll. We have worked closely with Hyperco to develop custom dual rates to ensure the best ride possible.

**The Rear Shocks should be installed at the same time as the Rear CoilSprings.**

1. Refer to the Factory Service Manual for CoilSpring Removal.
2. With the OEM Spring Removed and the Top of the StreetGrip Rear Shocks Bolted to the Frame, **Position the Spring in the Rear CoilSpring Pocket with the CLOSE COILS TO THE BOTTOM.**
3. While holding the Spring in place, Slowly Jack the Differential up until the bottom Shock Mounting can be attached. Refer to Shock Instructions for proper Shock Assembly.





### Front & Rear HQ Series Shocks



#### Recommended Tools

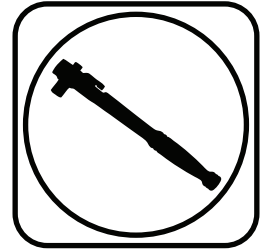

## Front & Rear HQ Series Installation Instructions

### Table of contents

Page	16.....	Rear Shock Installation
Page	17.....	Front Shock Installation
Page	18.....	Front Shock Installation & Adjustment

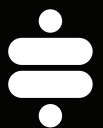



### Rear - Part # 22189844 - 7.55" HQ Series Shocks

#### Major Components .....In the box

Part #	Description	QTY
986-10-020	7.55" Stroke Shock	2
70011139	5/8" ID Shock Bushing (Installed in Shock)	2
90002068	Wide Trunnion (Installed in Shock)	2
70011138	3/4" ID Shock Bushing (Installed in Shock)	2
90002103	5/8" ID Shock Sleeve (Installed in Shock)	2

### Shock Installation

The Rear Shocks will be installed in conjunction with the Rear CoilSprings.

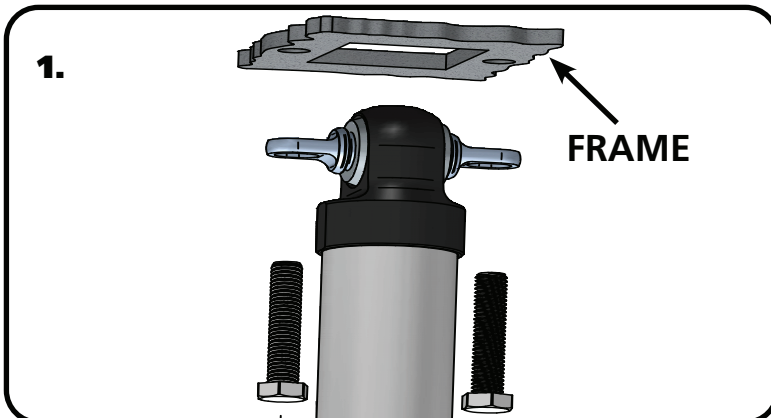

1. With the OEM Shock removed, install the Ridetech shock. Attach the Top of the Shock in the OEM Location using the OEM Hardware. It may be necessary to rotate the Trunnion to get it in the correct position. This can be done by sticking a screwdriver in one of the slots and spinning the trunnion in the shock bushing.

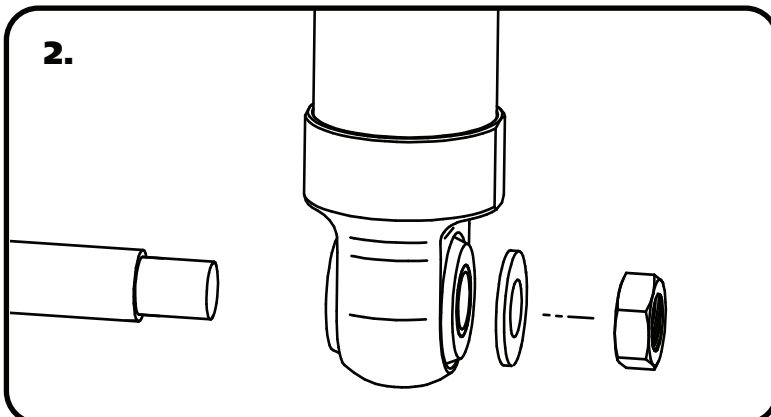

2. The Lower Shock is Bolted to the axle using the OEM shock mount and hardware. With the CoilSprings in place, Jack the Rear Differential up until the Shocks can be Bolted in place. Insert the Assembly onto the OEM Shock Stud. Install the OEM hardware and tighten.





### Front- Part #22169847 - 5.75" Stroke HQ Series Shocks

**Major Components** .....In the box

Part #	Description	QTY
986-10-044	5.75" Stroke Shock	2
70011139	5/8" ID Shock Bushing (Installed in Shock)	2
90002068	Wide Trunion (Installed in Shock)	2
70011141	Bushing Support Washer	4
70011140	Stem Bushing	4
99372006	3/8"-24 Thin Jam Nut	4

**Due to manufacturing tolerances it may be necessary to clearance the Control Arm to get the Shock through the Control Arm opening.**

### Shock Installation

Before installing the Shocks, the Control Arm Bushings, Upper Ball Joint, and CoilSprings should be installed.

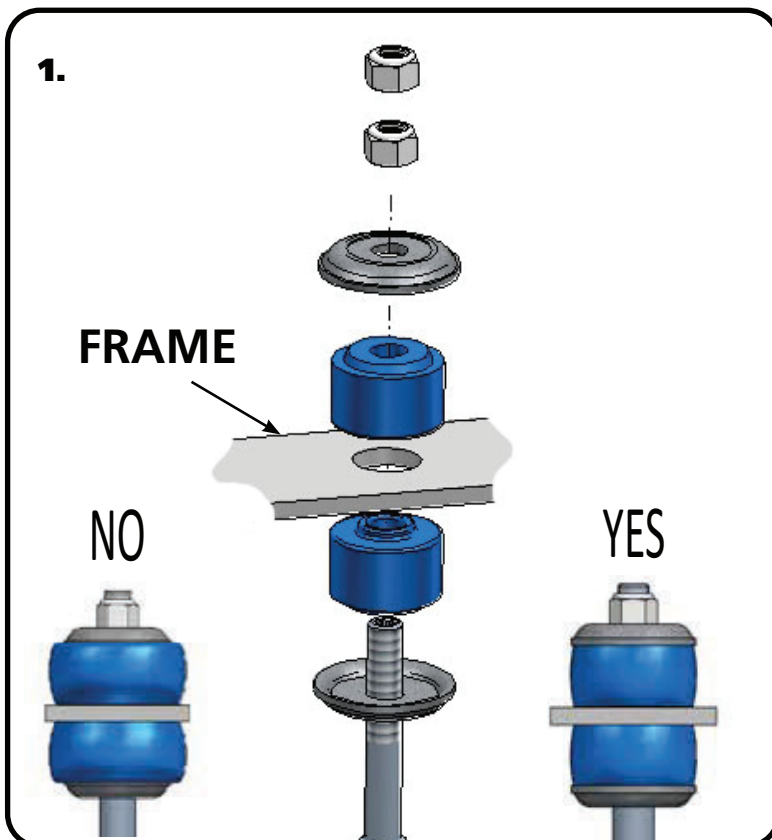

1. With the OEM shock removed, install the Ridetech shock. Remove the adjuster knob by loosening the set screw using the supplied Hex Key. Install a Bushing Support Washer on to the shock shaft followed by a Shock Stem Bushing. Insert the assembly through the factory shock hole in the frame. With the shock stud sticking through the frame, install a Shock Stem Bushing on to the shock stud followed with a Bushing Support Washer. Install a 3/8"-24 Thin Jam nut onto the threads and tighten to 35 inlbs. The Bushing should be tight, but not to the point that the bushing is bulging past the Support Washer. Install the 2nd 3/8-24 Thin Jam nut and tighten it against the first nut. Reinstall the Adjuster Knob, align the set screw with the FLAT side of the adjuster shaft that is sticking out of the top of the shock shaft.

**NOTE:** It may be necessary to remove the OEM Speed Nuts from the Control Arm to allow room for the Shock to slide through the opening in the Control Arm. The Speed Nuts can be reinstalled after the Shock is in position.



### Shock Installation and Adjustment

2.

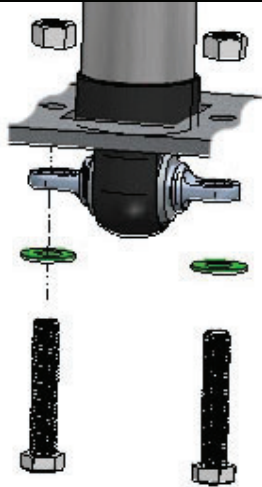

2. Attach the Trunnion to the OEM Control arm using the OEM hardware. It may be necessary to rotate the Trunnion to get it in the correct position. This can be done by sticking a screwdriver in one of the slots and spinning the trunnion in the shock bushing.

### Shock adjustment 101- Single Adjustable

#### Rebound Adjustment:

How to adjust your new shocks

The rebound adjustment knob is located on the top of the shock absorber protruding from the eyelet or stud top. You must first begin at the ZERO setting, then set the shock to a street setting of 12 or handling setting of 8.



-Begin with the shocks adjusted to the ZERO rebound position (full stiff). Do this by rotating the rebound adjuster knob clockwise until it stops.

-Now turn the rebound adjuster knob counter clockwise 12 clicks. This sets the shock at 12 for a street setting. If you are after a handling setting only go 8 clicks.

#### Take the vehicle for a test drive.



-if you are satisfied with the ride quality, do not do anything, you are set!

-if the vehicle is too soft increase the damping effect by rotating the rebound knob clockwise 3 additional clicks.

-if the vehicle is too stiff rotate the rebound adjustment knob counter clock wise 2 clicks and you are set!

Take the vehicle for another test drive and repeat the above steps until the ride quality is satisfactory.

#### Note:

**One end of the vehicle will likely reach the desired setting before the other end. If this happens stop adjusting the satisfied end and keep adjusting the unsatisfied end until the overall ride quality is satisfactory.**



**Part # 11059122 - 1958-1964 B-Body Rear Sway Bar**

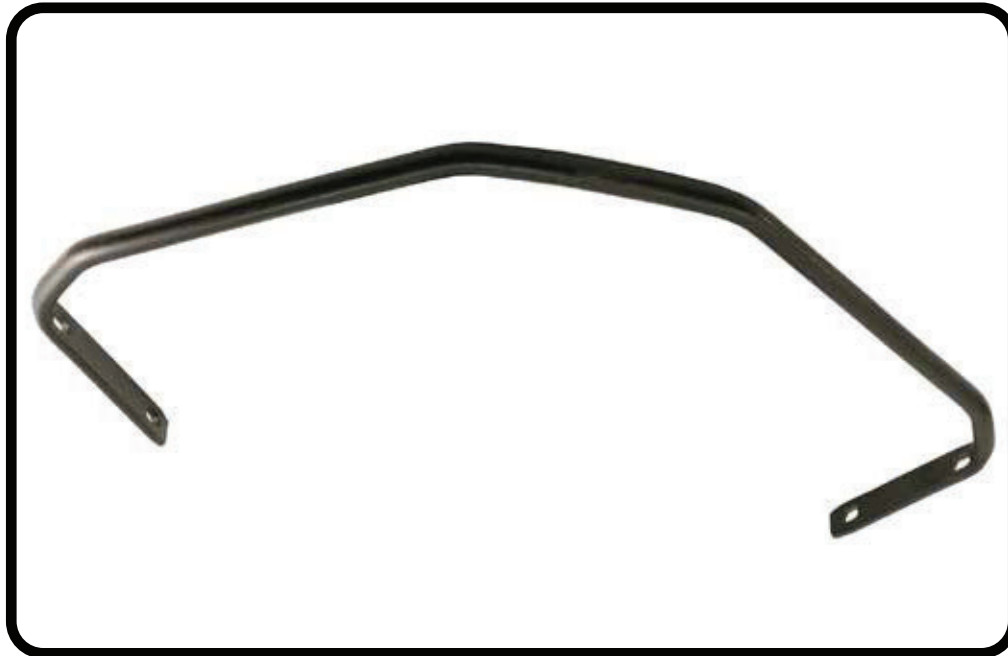

**Recommended Tools**

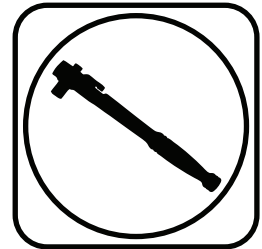

**1958-1964 B-Body Rear Sway Bar  
Installation Instructions**

Table of contents  
Page 20..... Included Components and Hardware List  
Page 21..... Sway Bar Installation



### Major Components & Hardware ....In the box

Part #	Description	QTY
90002535	Rear Sway Bar	1
90002536	Control Arm Spacer	4

#### Hardware Bag - Rear Sway Bar Kit

Part #	Description	Usage	QTY
99431003	7/16"-14 x 3" Hex Bolt	Sway Bar to Control Arm	4
99432001	7/16"-14 Nylok Nut	Sway Bar to Control Arm	4
99433002	7/16" SAE Flat Washer	Sway Bar to Control Arm	8

### Getting Started.....

These cars didn't come equipped with a Sway Bar, you will need to Drill Holes in the Lower Control Arms to attach the supplied Sway Bar.

The holes can be drilled with the arms on OR off the car. Measurements for the hole locations are provided below. The measurement is take from the CENTER of the front control arm bushing.

### Sway Bar Installation

3.

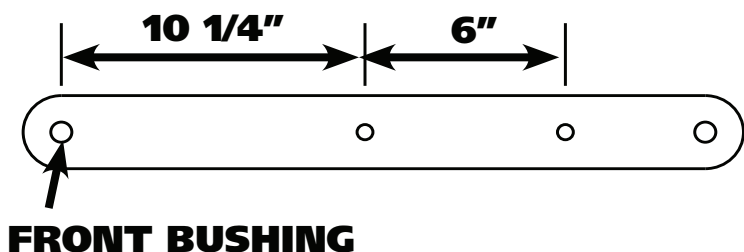

1. Holes will need to be drilled in the lower control arm to mount the rear swaybar. These holes should be drilled to 7/16". Measure back 10 1/4" from the center of the Front Bushing and make a mark centered top to bottom. Next measure back 6" from your first mark and Mark the Second Hole centered Top to Bottom. Drill the Locations with a 7/16" Drill Bit going through both Sides of the Arm. Repeat for both Arms.



### Sway Bar Installation



2. Insert the Supplied Spacer into the inside of the Control Arm at the Hole Locations. These Spacers will get Clamped in place by the Mounting Hardware after the Sway Bar is installed. These can be welded in place if desired.

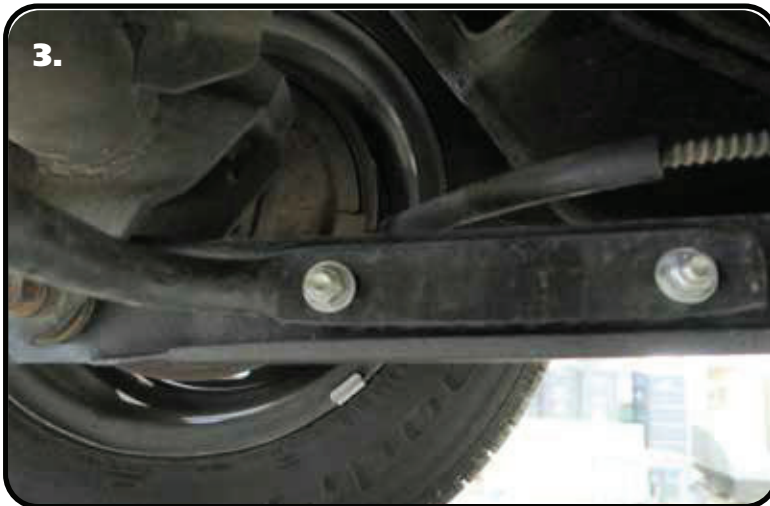

3. Slide the bar in Place with the CENTER OF THE BAR GOING UPWARD. Install a 7/16" washer on one of the 7/16"-14 x 3" Bolts and install one in each Front Hole to help hold it in place. Swing the Sway Bar into position and insert the Rear Bolt/Washer. Tighten Hardware.

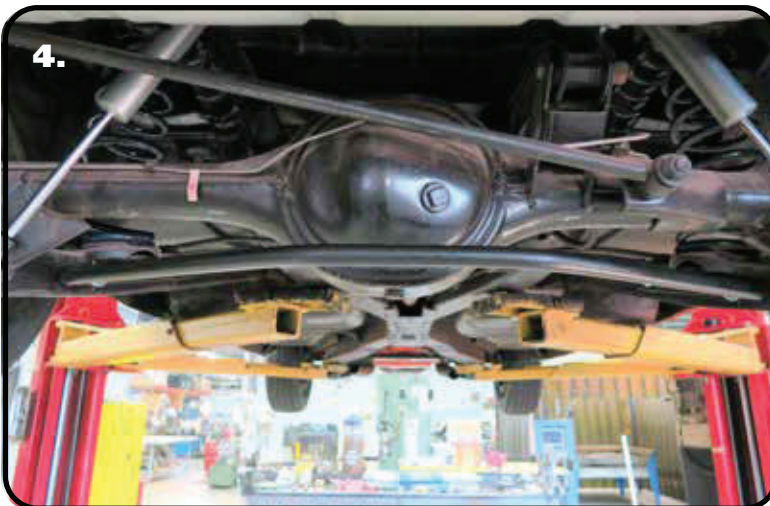

4. **Image 4** illustrates the Sway Bar installed. If your Sway Bar is hanging down below the axle with the shocks installed, the swaybar is installed upside down.