



350 S. St. Charles St. Jasper, In. 47546
Ph. 812.482.2932 Fax 812.634.6632

www.ridetech.com

Part # 11090298
58-60 Cadillac Air Suspension System

Front Components:

1 11082401 Front HQ Series Shockwave for Stock Lower Arms

Rear Components:

1 11104099 Rear CoolRide Kit

1 11100701 HQ Series Rear Shocks



Part # 11082401 - 57-60 Cadillac Front HQ Shockwave, OEM Control Arms

Recommended Tools

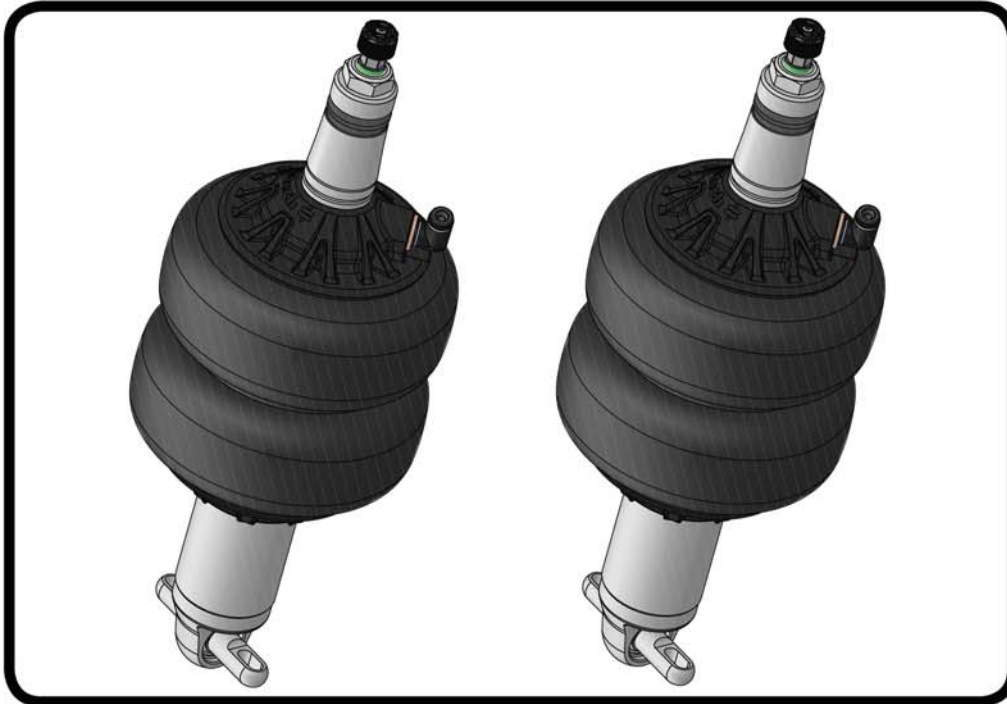

1000 Series Bellow, 2.75" Stud/Trunnion 2.9" Shock Installation Instructions

WE RECOMMEND REINFORCING THE LOWER CONTROL ARM IN THE AREA THAT THE TRUNNION BOLTS TO.

Table of contents

Page 2..... Included components

Page 3-4..... Shockwave Installation

Page 5-6..... Notes and Care of Your Shockwave & Shock Adjustment

ShockWave Dimensions:

Mount to Mount:

Compressed: 10.35"

Ride Height: 11.75"

Extended: 12.65"

THE DELRIN BALL REQUIRES A 3/4" HOLE FOR THE FLANGE TO GO THROUGH. THIS CAN BE DRILLED WITH A UNIBIT.

www.ridetech.com
812-482-2932





Major ComponentsIn the box

WE RECOMMEND REINFORCING THE LOWER CONTROL ARM IN THE AREA THAT THE TRUNNION BOLTS TO.

Item #	Part #	Description	QTY
1	982-10-802	2.9" Stroke HQ Series Shock	2
2	90009989	2.75" Stud Top (Installed on Shock) - Includes Adjuster Knob & Screw	2
3	24090199	1000 Series 6.5" Double Convoluted AirSpring	2
4	234-00-153	AirSpring Locking Ring (Installed on shock)	2
5	99055000	Locking Ring Set Screw (Installed on shock)	2
6	90002060	Universal Trunnion	4
7	90002313	2.75" Aluminum Stud Top Base	2
8	90001904	Bottom Delrin Ball	2
9	90001903	Top Delrin Ball	2
10	90001902	Delrin Ball Aluminum Top Cap	2
11	99562003	9/16"-18 Thin Nylok Nut	2
12	210-35-120-0	Adjuster Knob - (90009989 assembly)	2
13	90009969	#4-40 X 1/4" SS, 18-8 Pan Head Torx Cap - (90009989 assembly)	2
14	90001980	Trunnion Locking Rings	4
	70012161	2.75" Stud Top Metering Rod (installed in stud top)	2
	90001994	5/8" ID Bearing (installed in shock and eyelet)	4
	90001995	Bearing Snap Ring (installed in shock and eyelet)	8
	99311002	5/16" X 1 1/4" Hex Bolt	4
	99312003	5/16"-18 Nylok Nut	4
	99313002	5/16" SAE Flat Washer	8
	99371011	3/8"-16 x 6 1/2" Hex Bolt	2
	99372002	3/8"-16 Nylok Nut	2

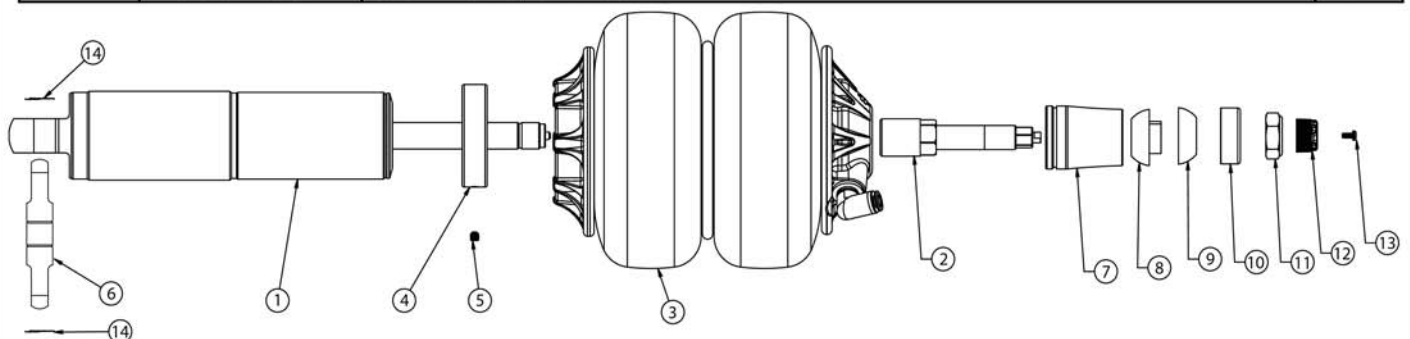

THE DELRIN BALL REQUIRES A 3/4" HOLE FOR THE FLANGE TO GO THROUGH. THIS CAN BE DRILLED WITH A UNIBIT.



ShockWave Installation



1. Raise and support vehicle at a safe, comfortable working height. Let the front suspension hang freely

2. Remove OEM coil spring and shock absorber. Refer to factory service manual for proper disassembly procedure.

3. Remove the factory shock nut from the top of the lower control arm. This is best done with a chisel and then ground smooth. The factory bump stop must also be removed. It has a nut on the bottom of the arm.



4. The upper coil spring retainer needs to be taken out as well. It is secured with rivets that need to be ground down or drilled out from the top. Some cars may have bolts instead of rivets. Also remove the Shock Bushing Cup and drill the Shock Hole to 3/4". A Unibit works well for this.

Note: If this is not done the top of the Shockwave will come in contact with the retainer and permanently damage the Shockwave.



5. For better sway bar alignment the end link must be cut down by 1" to 2 1/2" long. 3/8" x 6 1/2" Hex Bolts and 3/8" Nylok Nuts are included in the kit to replace the OEM hardware after shortening the sway bar end link.



ShockWave Installation

6.

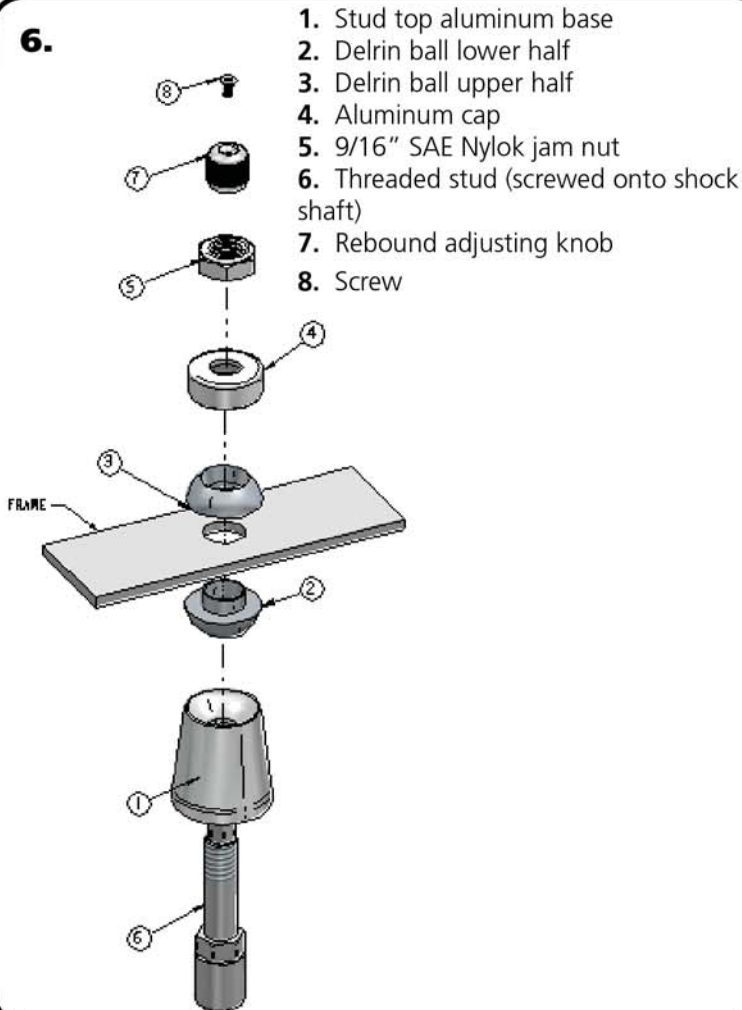

1. Stud top aluminum base
2. Delrin ball lower half
3. Delrin ball upper half
4. Aluminum cap
5. 9/16" SAE Nylok jam nut
6. Threaded stud (screwed onto shock shaft)
7. Rebound adjusting knob
8. Screw

Note: The airline must also be routed at this time. It can be ran through the subframe toward the rear of the vehicle.

6. The air fitting location can be rotated by twisting the bellow assembly separate of the shock. Place the Shockwave into the coil spring pocket with the stud sticking through the OEM shock hole. See assembly **Diagram 6**. OEM Shock hole **must** be drilled out to $\frac{3}{4}$ "

1. Stud top aluminum base
2. Delrin ball lower half
3. Delrin ball upper half
4. Aluminum cap
5. 9/16" SAE Nylok jam nut
6. Threaded stud (screwed onto shock shaft)
7. Rebound adjusting knob
8. Screw

TIGHTENING THE TOP 9/16"-18 NUT: SNUG THE NUT DOWN AGAINST THE TOP CAP. YOU NEED TO BE ABLE TO ARTICULATE THE SHOCK BY HAND.

7.

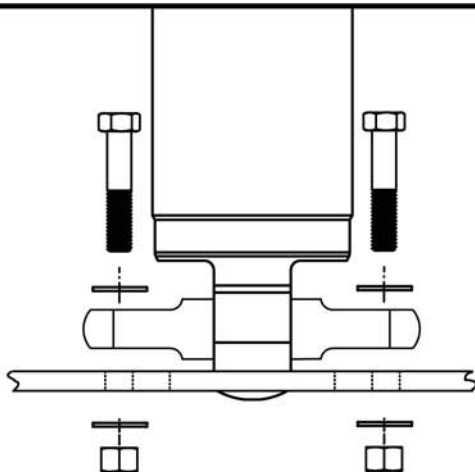

7. Raise the lower arm up to the Shockwave and bolt them together using the 5/16" x 1 1/4" Bolts, Washers, & Nylok Nuts supplied with the ShockWaves. Torque to 17 ftlbs.

6. Raise the lower control arm to full compression and double-check to make sure the Shockwave does not rub on anything at any-time. Allowing the Shockwave to rub on anything will cause failure and is not a warrant-able situation.

7. The best ride quality will occur around 50-60% suspension travel; depending on vehicle weight this typically occurs around 90-100 psi.



Notes and Care of your Shockwaves

NOTES:

WARNING: ATTEMPTING TO REMOVE THE AIR FITTING WILL DAMAGE IT AND VOID THE WARRANTY.

TIGHTENING THE TOP 9/16"-18 NUT: SNUG THE NUT DOWN AGAINST THE TOP CAP. YOU NEED TO BE ABLE TO ARTICULATE THE SHOCK BY HAND. WE TORQUE THE NUT TO 80 INLBS USING A 7/8" CROWS FOOT WRENCH ON A TORQUE WRENCH.

You can clock the airfitting location on the ShockWave by turning the AirSpring assembly of the shock. Make sure the fitting doesn't contact the frame.

When cutting the airline, use a razor blade. The cut needs to be a clean cut and square for the airline to seal properly.

The Locking ring on the shock is **NOT** adjustable. These rings are set at the factory to optimize the AirSpring stroke with the shock stroke.

The care and feeding of your new ShockWaves

1. Although the ShockWave has an internal bumpstop, **DO NOT DRIVE THE VEHICLE DEFLATED RESTING ON THIS BUMPSTOP. DAMAGE WILL RESULT.** The internal bumpstop will be damaged, the shock bushings will be damaged, and the vehicle shock mounting points may be damaged to the point of failure. This is a non warrantable situation.
2. Do not drive the vehicle overinflated or "topped out". Over a period of time the shock valving will be damaged, possibly to the point of failure. This is a non warrantable situation! If you need to raise your vehicle higher than the ShockWave allows, you will need a longer unit.
3. The ShockWave is designed to give a great ride quality and to raise and lower the vehicle. **IT IS NOT MADE TO HOP OR JUMP!** If you want to hop or jump, hydraulics are a better choice. This abuse will result in bent piston rods, broken shock mounts, and destroyed bushings. This is a non warrantable situation.
4. Do not let the ShockWave bellows rub on anything. Failure will result. This is a non warrantable situation.
5. The ShockWave product has been field tested on numerous vehicles as well as subjected to many different stress tests to ensure that there are no leakage or durability problems. Failures have been nearly nonexistent unless abused as described above. If the Shockwave units are installed properly and are not abused, they will last many, many years. ShockWave units that are returned with broken mounts, bent piston rods, destroyed bumpstops or bushings, or abrasions on the bellows will not be warrantied.



Shock Adjustment

Shock adjustment 101- Single Adjustable

Rebound Adjustment:

How to adjust your new shocks.

The rebound adjustment knob is located on the top of the shock absorber protruding from the eyelet.

You must first begin at the ZERO setting, then set the shock to a soft setting of 20.



-Begin with the shocks adjusted to the ZERO rebound position (full stiff). Do this by rotating the rebound adjuster knob clockwise until it stops.



-Now turn the rebound adjuster knob counter clock wise 20 clicks. This sets the shock at 20. (settings 21-24 are typically too soft for street use).

Take the vehicle for a test drive.



-if you are satisfied with the ride quality, do not do anything, you are set!

-if the ride quality is too soft increase the damping effect by rotating the rebound knob clock wise 3 clicks. **CONTINUE ON NEXT PAGE.**

Take the vehicle for another test drive.



-if the vehicle is too soft increase the damping effect by rotating the rebound knob clock wise 3 additional clicks.



-If the vehicle is too stiff rotate the rebound adjustment knob counter clock wise 2 clicks and you are set!

Take the vehicle for another test drive and repeat the above steps until the ride quality is satisfactory.

Note:

One end of the vehicle will likely reach the desired setting before the other end. If this happens stop adjusting the satisfied end and keep adjusting the unsatisfied end until the overall ride quality is satisfactory.

STILL HAVE QUESTIONS?

Tech line hours

Monday - Friday

8AM - 6PM (EST) 812-482-2932



350 S. St. Charles St. Jasper, In. 47546
Ph. 812.482.2932 Fax 812.634.6632
www.ridetech.com

Part # 11104099
58-64 Cadillac Rear CoolRide Kit

Components:

2	90006873	Air spring – 8” diameter, double convoluted, ¼” port
2	90000455	Upper cup bracket
2	90000070	Air spring roll plate

Hardware kit:

4	99372002	3/8” USS Nylok nut	Air spring to upper cup bracket
4	99373003	3/8” SAE flat washer	Air spring to upper cup bracket
2	99435002	7/16” x 8” stud	Cup bracket to frame
2	99432001	7/16” Nylok nut	Cup bracket to frame
2	99433002	7/16” flat washer	Cup bracket to frame
2	99371008	3/8” x 3 ½ ” bolt	Air spring to trailing arm
2	99373001	3/8” fender washer	Air spring to trailing arm
2	99373005	3/8” lock washer	Air spring to trailing arm

***** For Use With RideTech Rear Shock Kit *****

1. Raise and support vehicle at a safe and comfortable working height.
2. Support axle then remove coil spring and shock. Refer to service manual for proper disassembly procedure.



3. The lower coil spring retainer must be removed by cutting the welds. Grind all sharp edges smooth.



4. Install airline fitting into airspring using thread sealant. The airline will also need to be routed at this time. Bolt the upper cup bracket to the top of the airspring using the two 3/8" nyloc nuts supplied.

5. Thread the 8" all tread into the nut at the bottom of the cup and insert through existing hole in the upper coil spring pocket. This hole must be drilled open to 7/16". Cut off extra threads.



6. Use the 3/8" x 3 1/2" bolt and lower plate to secure bag to the lower arm.

7. Install the new shock into the oem location.

8. Make sure the bag cannot touch anything through full suspension travel.



350 S. St. Charles St. Jasper, In. 47546
Ph. 812.482.2932 Fax 812.634.6632

www.ridetech.com

Part # 11100701
61-64 Cadillac Rear HQ Series Shock Kit

Shock:

2 986-10-053 8.35" Stroke Stud Top/Bottom Shock Cartridge

Components:

8 70011140 Stem Bushings

8 70011141 Stem Washers

Hardware:

8 99372006 3/8"- 24 Thin Jam Nut Upper Shock Stud

