



INSTALLATION INSTRUCTIONS



Part # 11154013



Rear CoolRide Air Spring and RQ-S Shock Kit

1965-1970 Pontiac Fullsize



www.ridetech.com
812.482.2932





**Please Read And Understand All Instructions
And Warnings Prior To The Installation Of
This Product.**

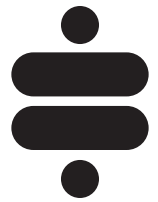

THANK YOU

Congratulations on your new Ridetech product! It's an honor that you've selected the Ridetech brand to upgrade your ride. Our products are developed around quality and performance without compromise. We're confident you'll have many years (and miles) of pure driving enjoyment.
Thank you for choosing Ridetech!

Road Map

Exploded View & Parts Listing	3-4
Air Spring Assembly/Installation	5
Shock Installation	6
Shock Tuning	7-8

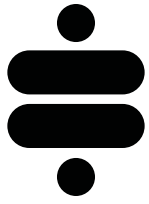

EXPLODED VIEWS AND PARTS LISTING

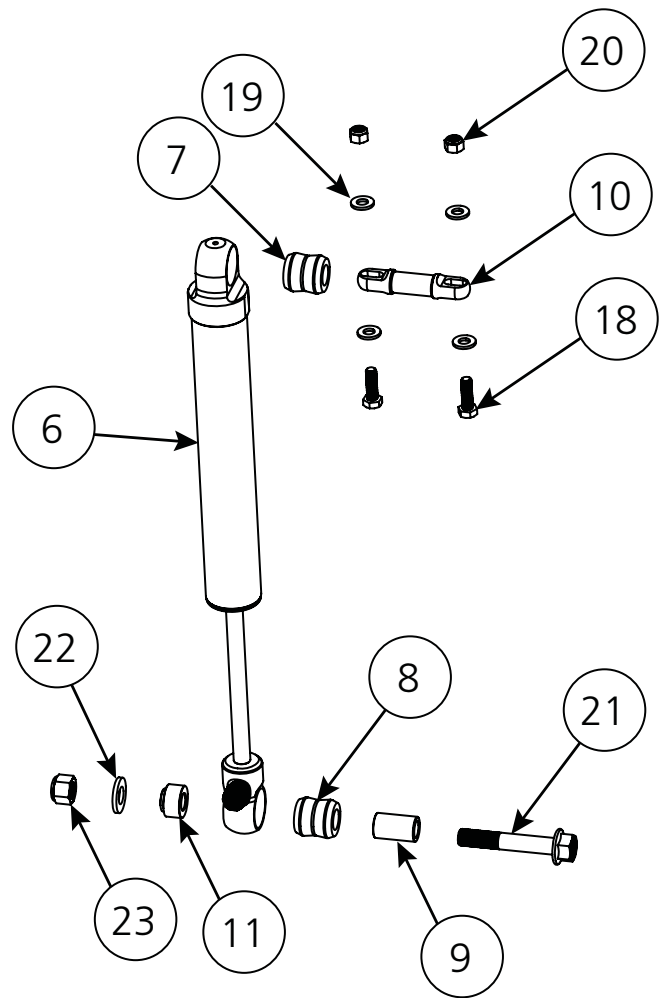
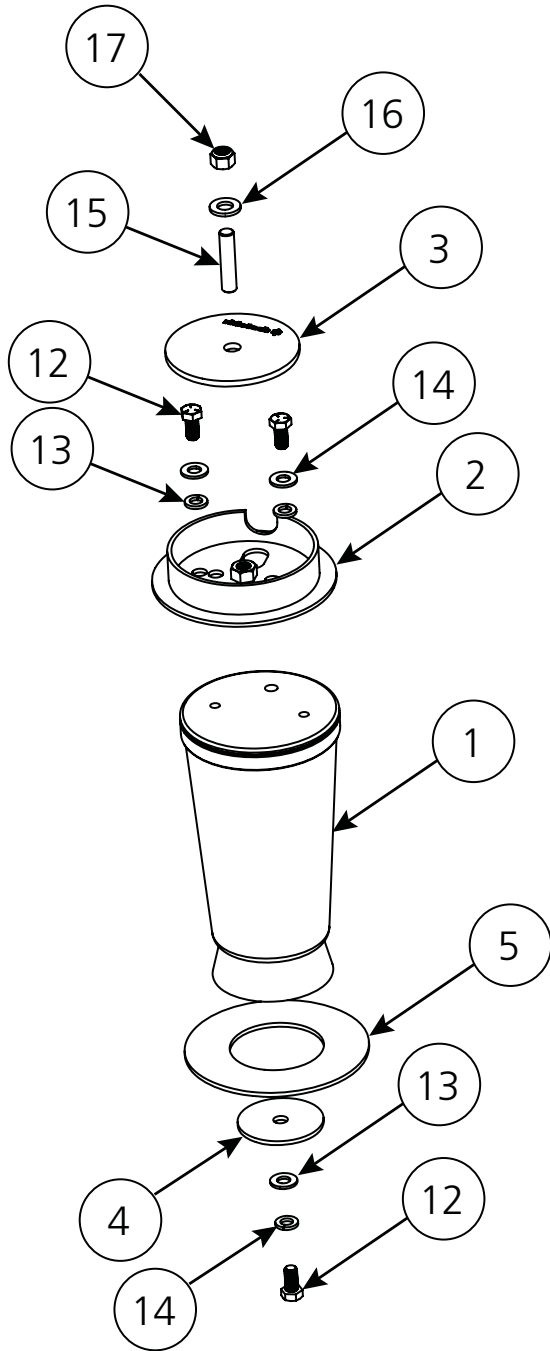
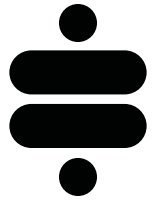

EXPLODED VIEWS AND PARTS LISTING

Item #	Part #	Description	Qty
Components			
1	90009000	Tapered Sleeve Air spring	2
2	90000056	Upper Cup Bracket	2
3	90000224	Upper Washer, 4" OD x .5" ID	2
4	90000291	Lower Washer, 2.563" OD x .438" ID	2
5	90000290	Air Spring Roll Plate	2
6	20489999	7.55" Stroke RQ-S Shock Cartridge	2
7	70011139	5/8" ID Shock Bushing	2
8	70011138	3/4" ID Shock Bushing	2
9	90002102	1/2" ID Inner Sleeve	2
10	90002068	Wide Trunnion	2
11	90000471	Shock Mount Spacer	2
Hardware			
Air Spring To Cup Bracket & Axle Mount			
12	99371001	3/8"-16 x 3/4" Bolt	6
13	99373003	3/8" SAE Flat Washer	6
14	99373005	3/8" Lock Washer	6
Cup Bracket To Frame			
15	99435003	7/16"-14 x 2" Threaded Stud	2
16	99433002	7/16" SAE Flat Washer	2
17	99432001	7/16"-14 Nylok Nut	2
Shock To Frame			
18	99311001	5/16"-18 x 1" Bolt	4
19	99313002	5/16" SAE Flat Washer	8
20	99312003	5/16"-18 Nylok Nut	4
Shock To Lower Control Arm			
21	99501070	1/2"-20 x 3" Flange Bolt	2
22	99503001	1/2" SAE Flat Washer	2
23	99502008	1/2"-20 Nylok Nut	2

Air Spring Assembly & Installation

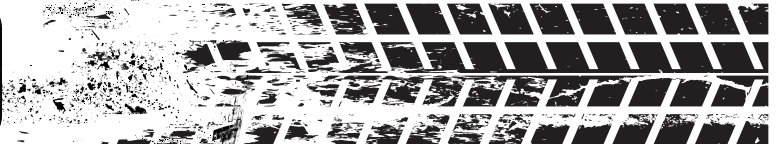

1. Raise the vehicle to safe & comfortable working height.
2. Support the axle, then remove the existing coil spring and shock. Refer to the factory service manual for the proper disassembly procedure. To help keep the axle in place, only do one side at a time.
3. Apply thread sealant to a 90 degree air fitting and screw it into the top of the air spring.
4. Place the upper air spring bracket on top of the air spring and secure with two 3/8" x 3/4" bolts, flat washers, and lock washers.
5. Thread the 2" stud into the nut in the bottom of the bracket.

6. Position the air spring assembly in the coil spring pocket with the stud protruding through the hole in the center of the coil spring pocket (Figure 1).

Place the 4" diameter washer over the protruding stud and secure with a 7/16" Nyloc nut and flat washer.

NOTE: Some vehicles may have a smaller hole in the spring pocket and may not require the 4" washer.

7. Place the air spring roll plate over the lower coil spring mount on the axle. Extend the air spring so the bottom of it seats on top of the plate. Some cars may require trimming of the coil spring retainer (Figure 2).

8. Slide a 3/8" lock washer, flat washer and the 2.5" OD washer onto a 3/8" x 3/4" bolt, insert through the coil spring mount on the axle and thread into the air spring.

Torque the 3/8" bolt to **15-20 ft-lbs.**



Figure 1



Figure 2

Upper Shock Mount and Shock Installation

9. Mount the shock trunnion (T-Bar) to the frame in the original mounting location using the supplied 5/16"-18 x 1" bolts, washers and nuts (Figure 3).

Torque to **15-17 ft-lbs.**

10. Use a 1/2"-20 x 3" flange bolt and 1/2" washer and Nylok nut to mount the shock to the axle mount (Figure 4 & 5).

Torque the 1/2" shock hardware to **75-85 ft-lbs.**

11. Ensure the air spring does not make contact with anything through its full range of motion.

Repeat on the opposite side.



Figure 3



Figure 4

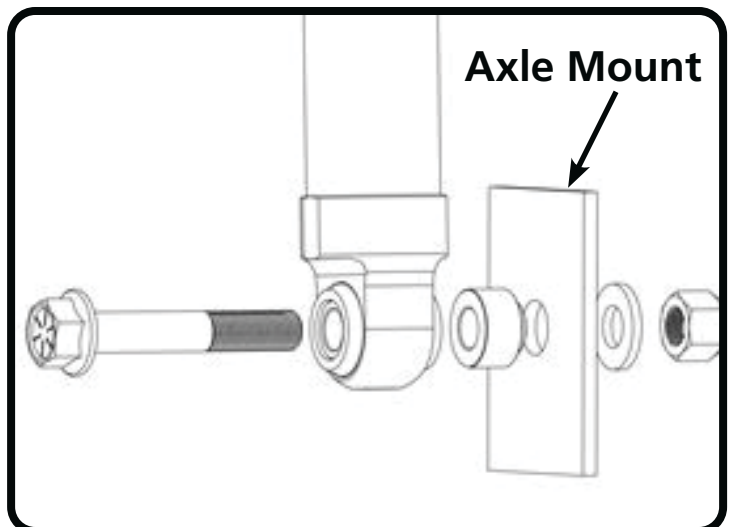

Figure 5



TUNING GUIDE

SINGLE-ADJUSTABLE SHOCKS



The Basics...

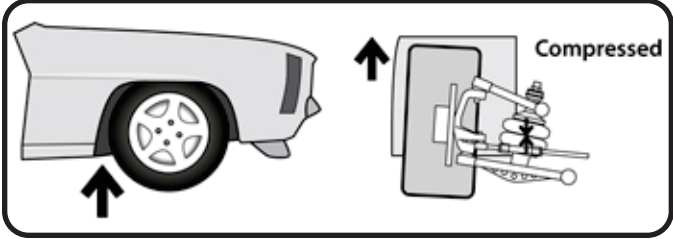

COMPRESSION

This typically occurs when you hit a bump in the road. The bump forces the wheel/tire/suspension assembly to "compress" or move upwards into the car.

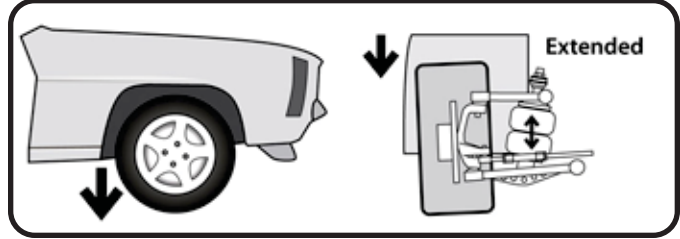

REBOUND

Rebound is the opposite of compression. This occurs when the wheel/tire/suspension assembly falls into a pothole, or simply "rebounds" from being compressed.

Where Are The Knobs?

RQ-S Series Shocks

- The adjustment knob is located on the top of the shock, either protruding from the side of the eyelet, or atop the stud.
- This knob provides rebound adjustment only.

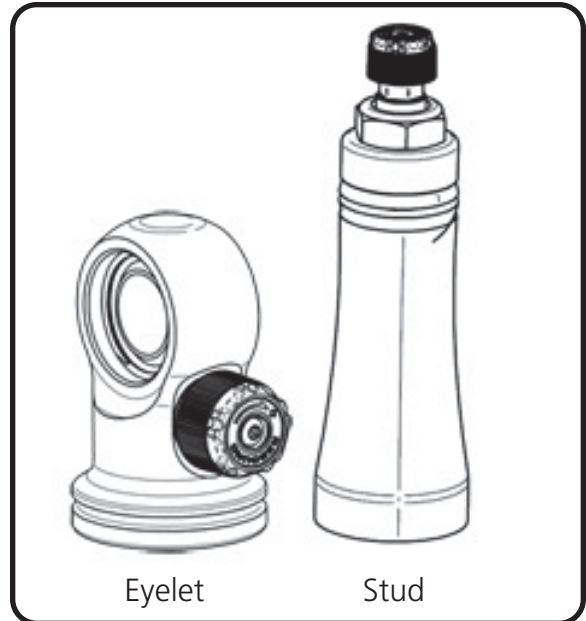

Knob Function

Counterclockwise

=
Softer



Clockwise

=
Firmer





TUNING GUIDE

SINGLE-ADJUSTABLE SHOCKS



Initial Rebound Setting

NOTE: Before jumping straight to a middle-of-the-road shock setting, we recommend you experience the full range of adjustment potential of your new shocks by first driving your vehicle at both the “full stiff” and “full soft” settings. Understanding how your shocks behave at these extremes will provide recognizable reference points as you attempt to dial in your settings.

1. Begin by setting your shocks to the “full stiff”, or minimal rebound position. You do this by turning the adjustment knob clockwise until it stops.

2. Now turn the adjustment knob counterclockwise 12 clicks. This is the approximate center of the adjustment range.

3. Take the vehicle for a test drive. Try to determine if you are experiencing any of the unwanted behaviors found at the extremes of the adjustment range. If you are satisfied with the ride quality and handling, you’re all set. Enjoy the ride!

4. If the vehicle feels too “floaty” or soft, turn the knob a few clicks clockwise to increase the damping effect.

If the ride quality is still too harsh or stiff, turn the knob a few more clicks counterclockwise to decrease the damping effect.

5. Take the vehicle for another test drive. If necessary, repeat the steps above until your desired optimal ride quality has been achieved.



General Guidelines

- The rear shocks typically have the most influence on ride quality. This is due to your seating position being closer to the rear than the front.
- Adjustments to the front shocks will generally require 3-4 clicks in any direction to be noticeable, while adjustments to the rear shocks may only require 1-2 clicks to be felt.
- Don’t be afraid to turn the knobs and experience the full adjustment range. You are not going to hurt anything and you can always go back if you adjust too far one way or the other.