



**INSTALLATION
INSTRUCTIONS**



Part # 11163510



Front HQ Series Coil-Overs

1967-1969 GM F-Body



www.ridetech.com
812.482.2932



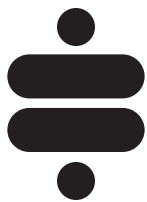

**Please Read And Understand All Instructions
And Warnings Prior To The Installation Of
This Product.**



THANK YOU

Congratulations on your new ridetech product! It's an honor that you've selected the ridetech brand to upgrade your ride. Our products are developed around quality and performance without compromise. We're confident you'll have many years (and miles) of pure driving enjoyment.
Thank you for choosing ridetech!

Road Map

Exploded View & Parts Listing	3
Coil-over Assembly	4-5
Installation Preparation	6
Coil-over Installation	7
Adjusting Ride Height	8-9
Shock Tuning Guide	10-11

Coil-Over Dimensions

Measured From Center-To-Center Of Shock Bearings

Compressed	10.48"
Ride Height	12.55"
Extended	14.08"

EXPLODED VIEWS AND PARTS LISTING

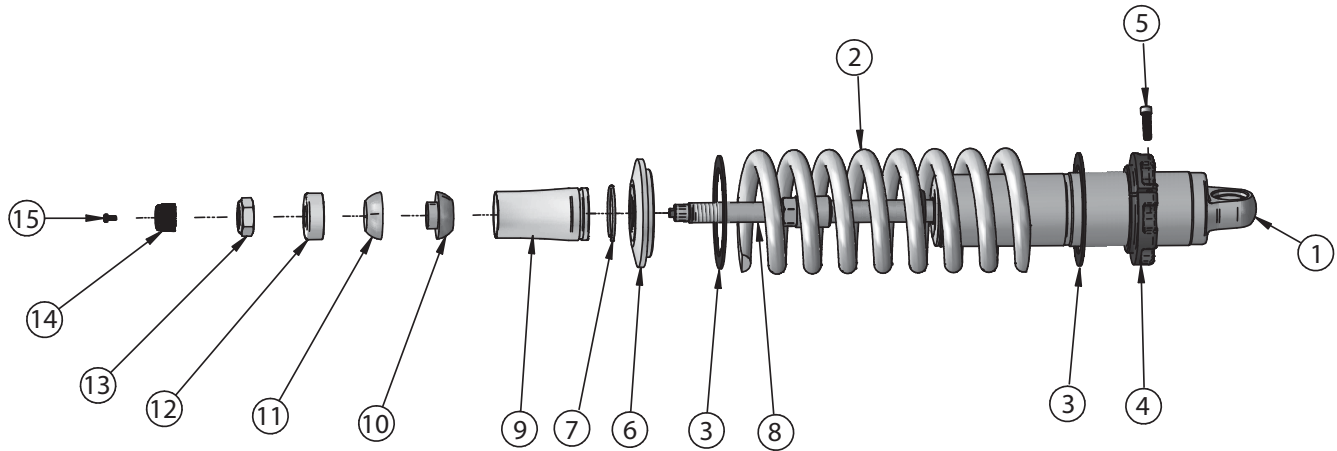

**THE DELRIN BALL REQUIRES A 3/4" HOLE FOR THE FLANGE TO PASS THROUGH.
THIS MAY BE DRILLED WITH A UNIBIT.**

Item #	Part #	Description	QTY
1	982-10-803	3.6" Stroke HQ Series Shock	2
2	59080700	Coilspring 8" 700lb	2
3	70010828	Delrin Spring Washer	4
4	803-00-199(kit)	Lower Spring Adjuster Nut (803-00-199 kit)	2
5	803-00-199(kit)	Adjuster Nut Locking Screw (803-00-199 kit)	2
6	803-00-199(kit)	Upper CoilSpring Retaining Plate (803-00-199 kit)	2
7	803-00-199(kit)	CoilSpring Plate Retaining Ring (803-00-199 kit)	2
8	90009989(kit)	2.75" Stud Adjuster Assembly	2
9	90002313	2.75" Stud Top Base	2
10	90001904	Delrin Ball Lower Half	2
11	90001903	Delrin Ball Top Half	2
12	90001902	Delrin Ball Upper Cap	2
13	99562003	9/16-18" Nylok Nut	2
14	210-35-120-0	Shock Adjuster Knob	2
15	90009969	Adjuster Knob Retaining Screw	2
	90001994	5/8" ID Bearing (installed in shock body)	2
	90001995	Bearing Snap Ring (installed in shock body)	4



COILOVER ASSEMBLY INSTRUCTIONS

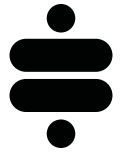

1. Thread the preload adjustment nut onto the shock from the bottom (Figure 1). A few threads of engagement is ok for now.



Figure 1

2. If it has not been removed already, remove the small plastic shipping spacer in the split of the adjustment nut (Figure 2).



Figure 2

3. Slide a Delrin washer over the shock and onto the adjustment nut (Figure 3).

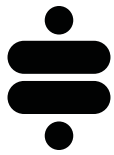

Figure 3

4. Slide the coil spring over the shock, onto the adjustment nut (Figure 4).



Figure 4



COILOVER ASSEMBLY INSTRUCTIONS

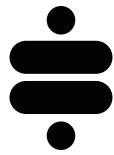

5. Slide a Delrin washer over the stud top and place on top of the coil spring, followed by the upper spring mount (Figure 5).



Figure 5

6. Slide the retainer clip over the adjustment knob and into the groove at the bottom of the stud top base. Make sure it snaps into place and is fully seated in the groove (Figure 6).



Figure 6

7. Thread the adjustment nut up the shock body to remove the slack and secure the spring and upper mount against the stud top base. Install the locking screw in the adjustment nut, but do not tighten yet (Figure 7). This screw will be tightened after your preload has been set.



Figure 7

8. Your assembled coilover is ready to be installed on the vehicle.



Figure 8

Installation Prep

1. Raise the vehicle to a safe and comfortable working height and remove the existing front shocks and coil springs. Refer to the factory service manual for the correct disassembly procedure.

2. Check the weld in the area highlighted in Figure 1. We have seen some very poor factory welds in this area. If it doesn't look adequate to support the vehicle, reweld this area.

3. Drill out the OEM shock hole to 3/4". This can be done with a Unibit. The coil-over stud top will come in contact with the coil spring retainer, so it must be opened up on the side towards the engine as highlighted in Figure 2. A die grinder works well here.



Figure 1

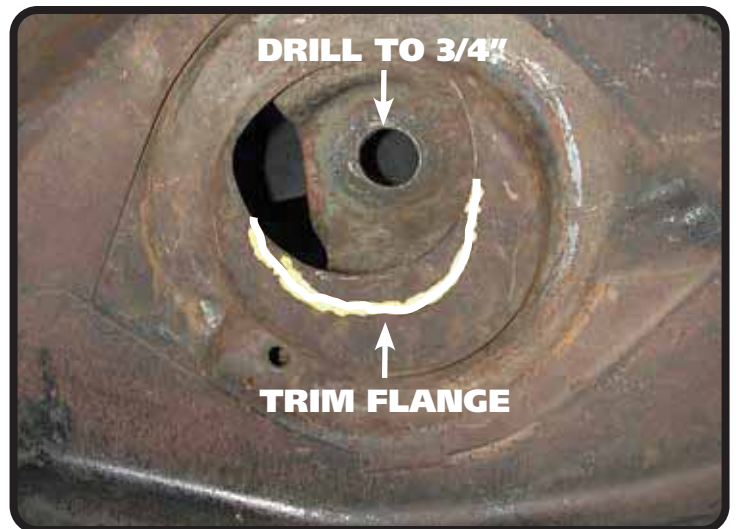
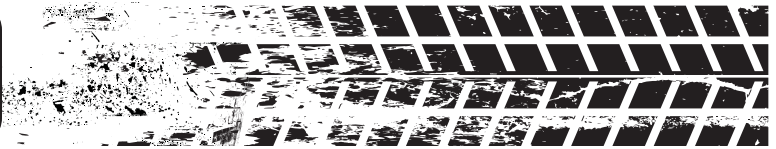

Figure 2

Coil-Over Installation



4. Place the coil-over into the coil spring pocket with the stud sticking through the OEM shock hole. See Figure 3. The OEM shock hole must be drilled out to $\frac{3}{4}$ ".

5. Tighten the $\frac{9}{16}$ " nut snugly against the top cap (#4). Do not over tighten. You should still be able to articulate the shock by hand. We torque the nut to 80 in-lbs using a $\frac{7}{8}$ " crowfoot wrench.

6. Insert an aluminum shock spacer into each side of the shock bearing, raise the lower arm up to the coil-over and attach the shock to the arm using the $\frac{1}{2}$ " x $3\frac{1}{4}$ " bolt and Nylok nut supplied with the lower arms (Figure 4). Torque to **75 ftbs**.

7. Raise the lower control arm to full compression and check to make sure the coil-over does not rub on anything through its range of motion.

NOTE: Optimal ride quality is usually achieved around 40-60% of suspension travel. Depending on vehicle weight, this typically occurs around 100 psi.

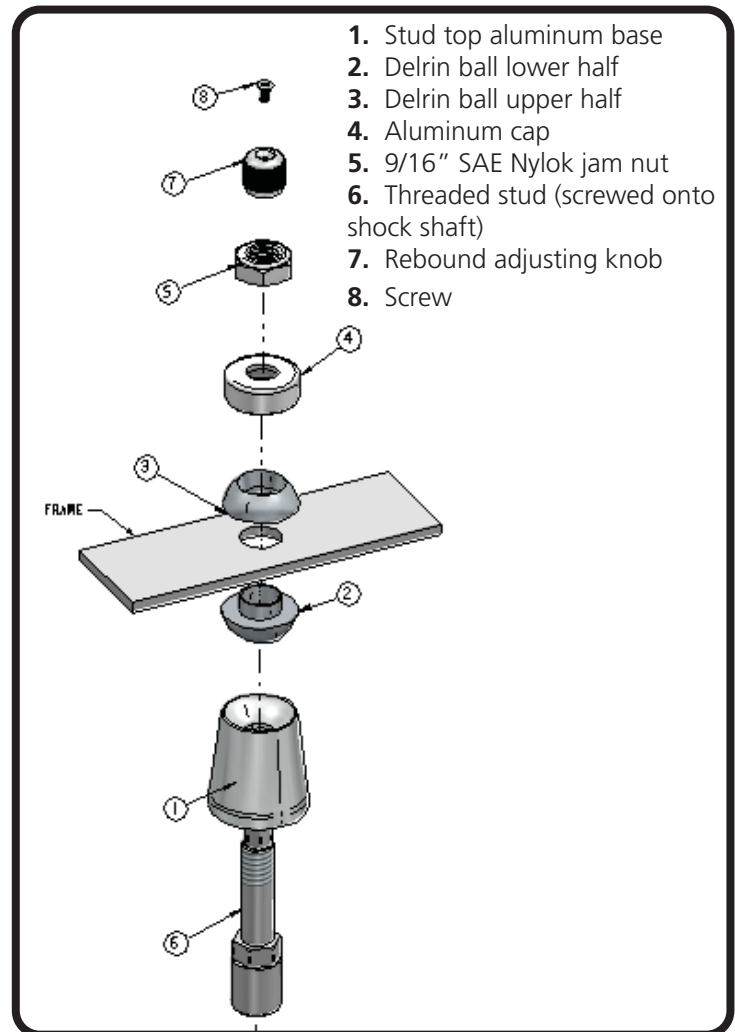

Figure 3

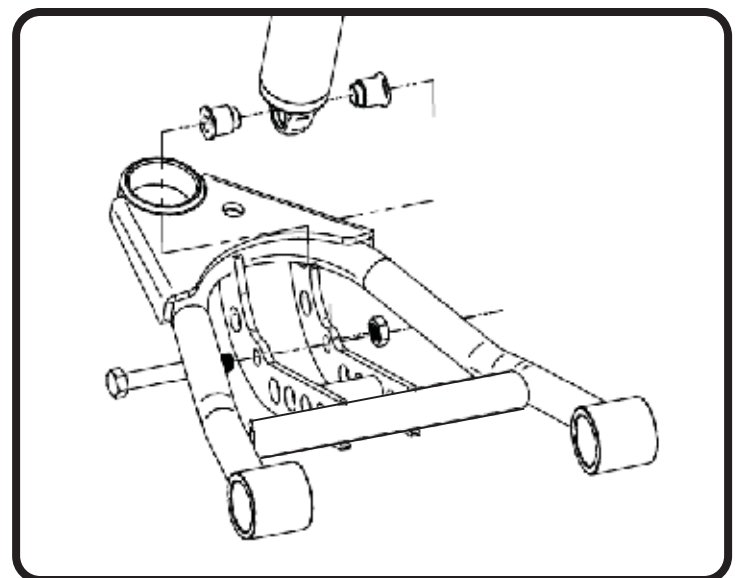

Figure 4

ADJUSTING RIDE HEIGHT

NOTE: Optimal ride quality and handling typically occurs when the shock absorber is sitting between 40-60% of its full travel at ride height. However, measuring the shock can be difficult on some applications. If you do not wish to measure your shocks, an easier method that is still quite effective is to measure wheel travel. See Steps 1-4 below for this alternate method. If you've determined that your shock travel is good, you may skip to Step 5 to jump straight to making any necessary ride-height adjustments.

1. With coilovers installed and the preload set, lower the vehicle to the ground. With the entire weight of the vehicle on the wheels, jounce the suspension and roll the vehicle forward and backward to release any suspension bind.

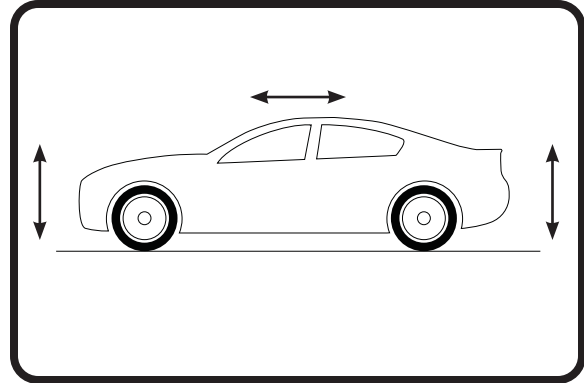

Figure 1

2. At the centerline of the wheel, take a measurement from the fender lip to the ground (Figure 2).

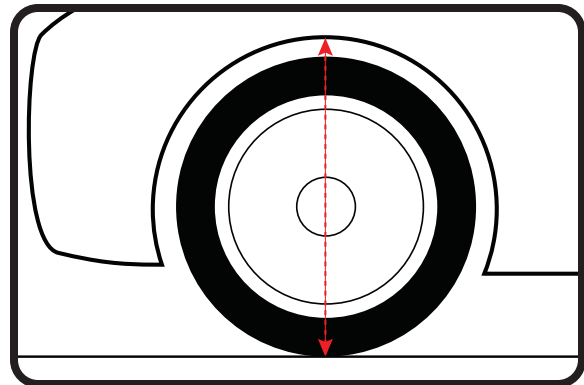

Figure 2

3. Lift the vehicle by the frame until the wheel is barely touching the ground. Take another measurement from the fender lip to the ground (Figure 3).

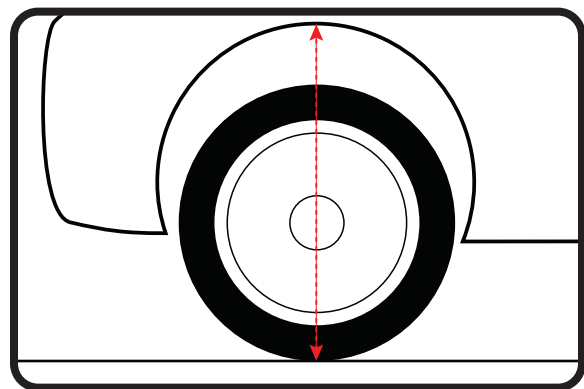

Figure 3

4. The difference between the measurements taken in Steps 2 and 3 is your **extension travel** at the wheel. A minimum of 1.5" of extension travel (at the wheel) is typically needed to prevent the shock from topping out. If you have more than 3" of extension travel, you may be at risk of bottoming out the shock and need to increase the ride height.



ADJUSTING RIDE HEIGHT



5. With coilovers installed and the preload set, lower the vehicle to the ground. With the entire weight of the vehicle on the wheels, jounce the suspension and roll the vehicle forward and backward to release any suspension bind. Evaluate your ride height.

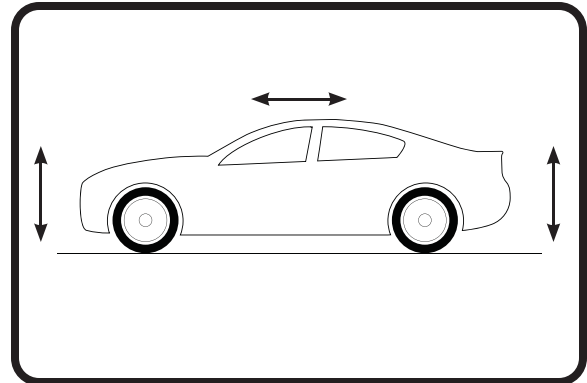

Figure 4

6. If you determine you need to adjust the ride height, raise the vehicle by the frame and allow the suspension to hang freely.

7. Loosen the locking screw on the coilover adjustment nut just enough to be able to turn the nut. **Do not remove the locking screw.** (Figure 5).



Figure 5

8. Measure the distance from the bottom of the adjustment nut to the flat of the shock body. We recommend recording this measurement for reference (Figure 6).



Figure 6

9. Using a spanner wrench, thread the nut up or down the shock body to achieve the desired ride height (Figure 7). Tighten the locking screw to secure the adjustment nut in place. Torque to **18 in-lbs.**



Figure 7

10. Lower the vehicle to the ground, jounce the suspension and roll the vehicle forward and backward to release any suspension bind.

11. Recheck your ride height. If you need to adjust, repeat Steps 6-10.

12. Once your desired ride height has been achieved, refer to the Shock Tuning Guide to dial in your shocks.



TUNING GUIDE

SINGLE-ADJUSTABLE SHOCKS



The Basics...

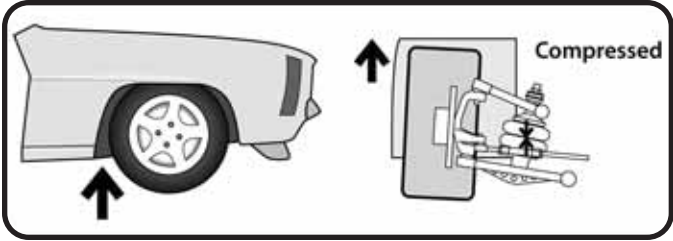

COMPRESSION

This typically occurs when you hit a bump in the road. The bump forces the wheel/tire/suspension assembly to "compress" or move upwards into the car.

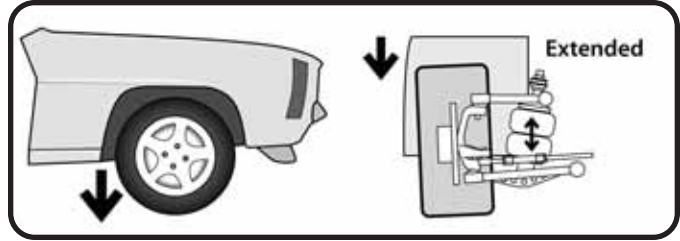

REBOUND

Rebound is the opposite of compression. This occurs when the wheel/tire/suspension assembly falls into a pothole, or simply "rebounds" from being compressed.

Where Are The Knobs?

HQ Series Shocks

- The adjustment knob is located on the top of the shock, either protruding from the side of the eyelet, or atop the stud.
- This knob provides rebound adjustment only.

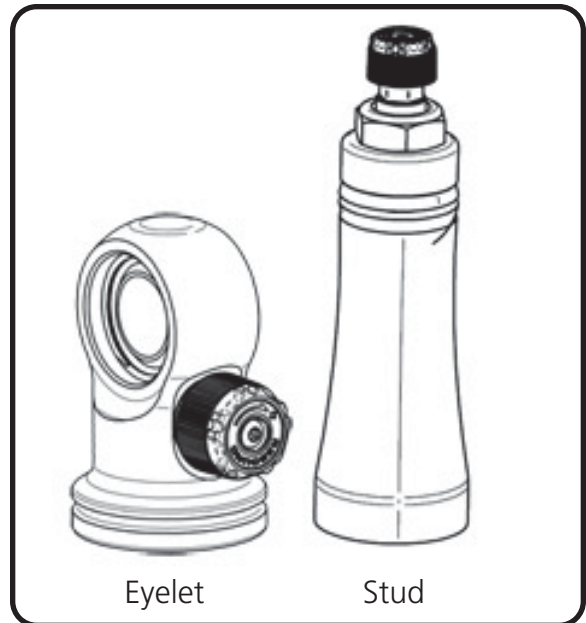

Knob Function

Counterclockwise

=
Softer



Clockwise

=
Firmer





TUNING GUIDE

SINGLE-ADJUSTABLE SHOCKS



Initial Rebound Setting

NOTE: Before jumping straight to a middle-of-the-road shock setting, we recommend you experience the full range of adjustment potential of your new shocks by first driving your vehicle at both the “full stiff” and “full soft” settings. Understanding how your shocks behave at these extremes will provide recognizable reference points as you attempt to dial in your settings.

1. Begin by setting your shocks to the “full stiff”, or minimal rebound position. You do this by turning the adjustment knob clockwise until it stops.

2. Now turn the adjustment knob counterclockwise 12 clicks. This is the approximate center of the adjustment range.

3. Take the vehicle for a test drive. Try to determine if you are experiencing any of the unwanted behaviors found at the extremes of the adjustment range. If you are satisfied with the ride quality and handling, you’re all set. Enjoy the ride!

4. If the vehicle feels too “floaty” or soft, turn the knob a few clicks clockwise to increase the damping effect.

If the ride quality is still too harsh or stiff, turn the knob a few more clicks counterclockwise to decrease the damping effect.

5. Take the vehicle for another test drive. If necessary, repeat the steps above until your desired optimal ride quality has been achieved.



General Guidelines

- The rear shocks typically have the most influence on ride quality. This is due to your seating position being closer to the rear than the front.
- Adjustments to the front shocks will generally require 3-4 clicks in any direction to be noticeable, while adjustments to the rear shocks may only require 1-2 clicks to be felt.
- Don’t be afraid to turn the knobs and experience the full adjustment range. You are not going to hurt anything and you can always go back if you adjust too far one way or the other.