



**INSTALLATION
INSTRUCTIONS**



Part # 11172798/11172799



Subframe

1970-1981 Camaro/Firebird



www.ridetech.com
812.482.2932



**Please Read And Understand All Instructions
And Warnings Prior To The Installation Of
This Product.**

THANK YOU

Congratulations on your new Ridetech product! It's an honor that you've selected the Ridetech brand to upgrade your ride. Our products are developed around quality and performance without compromise. We're confident you'll have many years (and miles) of pure driving enjoyment.
Thank you for choosing Ridetech!

Road Map

Pre-Installation Notes	3-5
Torque Specifications Summary	6
Components Listing	7
Hardware Kits	8
Exploded Views	9-13
Disassembly	14
Upper Control Arms	15
Engine Mount Bushings	16
Lower Control Arms	17-18
Steering Rack	19-20
Transmission X-Member	21
Hub/Spindle Assembly	22
Caliper Brackets	23
Steering Arms (Hub Spindle)	24
Steering Arms (Pin Spindle)	25
Spindle Assembly Installation	26
Steering Assembly	27-28
Front Sway Bar Installation	29-31
Subframe Installation	32
Final Assembly	33-34

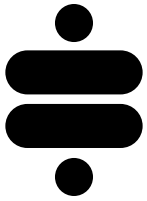

PRE-INSTALLATION NOTES PLEASE READ

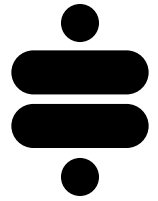

Installing this system requires removal of the engine and transmission. Due to the numerous variations in engine/transmission configurations, customizations, and vehicle conditions, the written instructions on the following pages do not include detailed steps on how to remove your particular engine and transmission.

If you require guidance on the disassembly portion of the install, we recommend referring to the factory service manual, or seeking the assistance of a reputable, experienced mechanic.



IMPORTANT NOTE



If your vehicle has the factory floor-shift automatic transmission, there is a frame-mounted neutral safety switch linkage that must be relocated to the ridetech subframe. You may purchase Ridetech kit # 11169513 to relocate and attach this linkage to the new subframe.

STEERING RACK

This system was designed to be used with a '79-'93 Mustang steering rack (purchased separately). We chose a PSC-RA33500 for the installation outlined in these instructions, but an equivalent '79-'93 Mustang rack from another vendor should also be sufficient.

If you are using the stock GM power steering pump, we recommend installing a Borgeson 899001 pressure-reducing kit to lower the pressure of the GM pump. This will improve the feel and response of the '79-'93 Mustang steering rack.

If you are running the stock steering column, we also recommend installing the ridetech steering column u-joint adapter kit.
Ridetech kit # 12319505.

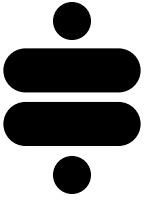

PRE-INSTALLATION NOTES PLEASE READ

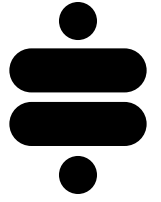

ENGINE MOUNTS

This system requires the use of one of the engine mount options listed below (purchased separately).

ENGINE MOUNT OPTIONS	
DESCRIPTION	RIDETECH KIT #
Small-Block/Big-Block Chevy	11169511
GM LS	11169512
GM Gen V LT	11169514

SUBFRAME CONNECTORS

If your vehicle is currently outfitted with Ridetech '74-'81 subframe connectors, you will require the Ridetech 11179512 adapter puck kit to achieve compatibility with your new Ridetech subframe.

If you have Ridetech '70-'73 subframe connectors, no adapter kit is necessary. Your subframe connectors are already compatible.

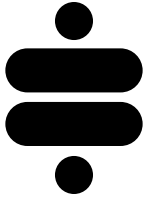

PRE-INSTALLATION NOTES PLEASE READ

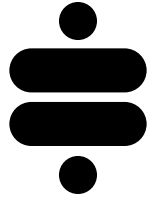

CLUTCH BRACKET

If you choose to retain your stock mechanical clutch, we recommend installing the Ridetech clutch bracket kit. Ridetech kit # 11179511.

BRAKES

Stock '70-'81 brakes are not compatible with the pin spindle subframe kit (11172799). The pin spindle kit requires '67-'69 F-Body brakes.

BODY-MOUNT BUSHINGS

Installing this system provides an excellent opportunity to replace/upgrade your body-mount bushings. We recommend installing the Ridetech subframe bushing kit. Ridetech kit # 81001000.

Ridetech recommends this system be installed by a professional technician or experienced, reputable mechanic. Modification or improper installation of this product may result in loss of warranty. Proper installation and setup of your suspension is critical to the safe and enjoyable operation of your vehicle. Failure to follow the guidelines and specifications provided in these instructions may result in damage to your vehicle and/or death or serious injury to you, your passengers, or other motorists. Ridetech will not be held liable for any damage, loss or injury occurring from the use of this product outside of its intended application and design parameters.



TORQUE SPECIFICATIONS



LOCATION	TORQUE SPEC
1/2"-13 Upper Control Arm Bolts	75 ft-lbs
1/2"-13 Lower Control Arm Bolts	75 ft-lbs
1/2"-13 Upper & Lower Shock Mount Bolts	75 ft-lbs
1/2"-13 Steering Rack Bolts	75 ft-lbs
M12 Hub To Spindle Bolts	99 ft-lbs
1/2"-13 Caliper Bracket To Spindle Bolts	90 ft-lbs
1/2"-13 Steering Arm Bolts	90 ft-lbs
Upper Ball Joint Nut	50 ft-lbs
Lower Ball Joint Nut	65 ft-lbs
1/2"-20 Tie-Rod Stud Castle Nut	35 ft-lbs
5/8"-18 Tie-Rod Nylok Nut	45 ft-lbs
3/8"-16 Sway Bar Mounting Strap Bolts	32 ft-lbs
M10 Sway Bar End Link Nuts	49 ft-lbs
1/2"-20 Subframe Bolts	30-40 ft-lbs
5/8"-11 Subframe Bolts	75-90 ft-lbs
7/16"-14 Transmission X-Member Bolts	45 ft-lbs
M14 Caliper To Caliper Bracket Bolts	125 ft-lbs

COMPONENTS LISTING

ITEM #	PART #	DESCRIPTION	QTY
1	90003909	70-81 F-BODY SUBFRAME	1
TRANSMISSION X-MEMBER: 11172751			
2	90003913	70-81 F-BODY SUBFRAME TRANSMISSION X-MEMBER	1
3	90003890	67-81 F-BODY SUBFRAME TRANSMISSION SPACER BLOCK	1
UPPER CONTROL ARMS: 11163690			
4	90003875	67-81 F-BODY SUBFRAME BILLET UPPER CONTROL ARM	2
5	70016277	1.325" OD DELRIN BUSHING	8
6	90003878	SLEEVE; .506 ID X .705 OD X 1.925 OAL	4
7	90000908	101-10015 UPPER BALL JOINT	2
8	99251022	1/4-20 X 1 HCS GR8 BLACK	8
9	99252007	1/4-20 NYLOK FLANGE NUT GR8 BLACK	8
LOWER CONTROL ARMS: 11172890			
10	90003910	70-81 F-BODY SUBFRAME LOWER CONTROL ARM - DRIVER (SHOWN)	1
11	90003911	70-81 F-BODY SUBFRAME LOWER CONTROL ARM - PASSENGER	1
12	70017359	BUSHING	4
13	90000898	101-10013 LOWER BALL JOINT	2
FRONT SWAY BAR: 11179105			
14	90003882	67-69 F-BODY SUBFRAME FRONT SWAY BAR	1
15	90001258	SWAY BAR LINK ADAPTER BUSHING	4
16	90003842	CCTY END LINK 10mm 90 DEGREE	4
17	90001346	BILLET SWAY BAR MOUNT	2
18	70015016	1.5" ID LINED SWAY BAR BUSHING	2
19	90002275	WASHER, COPPER CRUSH .39 x .62	4
20	99115001	M10-1.5 x 1.5" THREADED STUD	2
STEERING KIT: 11179510			
21	90003481	STEERING ARM - DRIVER	1
22	90003482	STEERING ARM - PASSENGER	1
23	90003400	TIE ROD ADJUSTER, 5/8-18 LH THREAD	2
24	90003883	67-81 F-BODY SUBFRAME TIE ROD STUD	2
25	90002676	TIE ROD SPACER	4
26	90001582	HEIM END 5/8-18 LH THREAD X 5/8 I.D.	2
27	90002672	SLEEVE; .750 OD X .563 ID X 3.00 OAL	2
28	70015348	POLY BUSHING (Pack of 4) - For steering rack and engine mounts.	2
29	90003879	ECCENTRIC BOLT; 1/2-13 X 4 1/2" GR8	4
30	90003880	ECCENTRIC BOLT WASHER	8
31	90003881	LOWER CONTROL ARM SPACER	8
HUB SPINDLES: 11009312 (Only included with 11172798 subframe kit)			
32	70015750	RIDETECH SPINDLE - BOLT-ON HUB	2
33	90003535	THREADED INSERT - 1/2"-13 UNC	4
CALIPER BRACKETS: 11009546 (Only included with 11172798 subframe kit)			
34	90003547	CALIPER BRACKET - PASSENGER	1
35	90003548	CALIPER BRACKET - DRIVER	1
36	90003549	CALIPER BRACKET SPACER	4
PIN SPINDLES: 11009303 (Only included with 11172799 subframe kit)			
37	11009304	PIN SPINDLE, 2" DROP	2
38	99501054	1/2-20 X 2 1/2 FHCS GR8	4

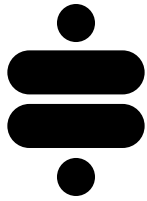

HARDWARE KITS

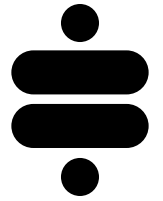

HARDWARE KIT - 99010277			
ITEM #	PART #	DESCRIPTION	QTY
SUBFRAME TO CAR			
37	99501012	1/2-20 X 3 HCS GR8	2
38	99502002	1/2-20 SAE GR8 Nylok Nut	2
39	99503014	1/2 SAE FLAT WASHER GR8	4
40	99621039	5/8-11 X 3 1/2 HCS GR8	4
41	99623001	5/8 SAE FLAT WASHER	4
42	99623002	5/8 SPLIT LOCKWASHER	4
LOWER CONTROL ARM TO SUBFRAME			
43	99502009	1/2-13 USS GR8 NYLOK NUT	4
SHOCKS TO SUBFRAME			
44	99501064	1/2-13 X 2 3/4 Hex Bolt GR8	4
45	99502009	1/2-13 USS GR8 NYLOK NUT	4
46	99503014	1/2 SAE FLAT WASHER GR8	8
STEERING RACK TO SUBFRAME			
47	99501079	1/2-13 X 9 1/2 HCS GR8	2
48	99502009	1/2-13 USS Gr. 8 NYLOK NUT	2
49a	99503014	1/2 SAE FLAT WASHER GR8	2
49b	99503021	1/2 USS FLAT WASHER GR8	2
UPPER CONTROL ARM TO SUBFRAME			
50	99502009	1/2-13 USS Gr. 8 NYLOK NUT	4
51	99501080	1/2-13 X 11 HCS GR8	2
52	99503016	1/2" MIL-SPEC WASHER	4
STEERING ARM TO SPINDLE			
53	99501043	1/2-13 X 2 HCS GR8	4
54	90002263	Red Loctite Tube; 1ml Tube	1
55	99503014	1/2 SAE FLAT WASHER GR8	4
STEERING			
56	99502017	1/2-20 CASTLE NUT	2
57	99952003	1/8 cotter pin	2
58	99622006	5/8-18 THIN NYLON JAM NUT	2
59	99562002	9/16-18 HEX FIN JAM NUT ZINC	2

SWAY BAR HARDWARE KIT - 99010278			
ITEM #	PART #	DESCRIPTION	QTY
STRAP TO SUBFRAME			
56	99371005	3/8-16 X 1 1/4 HCS GR8	4
57	99373002	3/8 SAE FLAT WASHER	8
58	99372001	3/8-16 GR8 NYLON INSERT L/N	4
POSILINK			
59	99112002	M10-1.5 Nylon Insert L/N	4
60	99373003	3/8 SAE FLAT WASHER GR 5	4

X-MEMBER HARDWARE KIT - 99010279			
ITEM #	PART #	DESCRIPTION	QTY
X-MEMBER TO SUBFRAME			
61	99431021	7/16-14 X 1 1/4 HCS GR8	4
62	99432010	7/16-14 NYLON INSERT L/N GR8	4
63	99433005	7/16 SAE GR8 FLAT WASHER	8

HUB SPINDLE HARDWARE KIT - 99010230			
ITEM #	PART #	DESCRIPTION	QTY
SPINDLE TO HUB			
64	99121020	M12-1.75 X 40 SHCS, BLACK	6
-	90002263	Red Loctite Tube; 1ml Tube	1
STEERING ARMS			
(Hardware Below Not Used In This Kit)			
-	99501043	1/2-13 X 2 Hex Cap Screw GR8	2
-	99501026	1/2-13 X 2 1/4 Hex Bolt GR8	2
-	99503014	1/2 SAE FLAT WASHER GR8	4

PIN SPINDLE HARDWARE KIT - 99010174			
ITEM #	PART #	DESCRIPTION	QTY
STEERING ARM TO SPINDLE			
38	99501054	1/2"-20 x 2 1/2" FSCS	2
40	99502002	1/2-20 SAE GR8 Nylok Nut	6
NOT REQUIRED FOR THIS KIT			
NA	99501071	1/2"-20 x 3" FSCS	4
NA	99621001	5/8-18 x 1" BOLT GR8	2
NA	99502005	1/2"-20 X 2" BOLT GR8	2
NA	99952003	1/8 x 1-1/2 cotter pins	4

C5/C6 CALIPER BRACKETS HARDWARE KIT - 99010239			
ITEM #	PART #	DESCRIPTION	QTY
BRACKET TO CALIPER			
65	99141007	M14-2.0 x 45MM HEX HEAD	4
66	99143001	M14 Flat Washer; Grade 10.9	4
BRACKET TO SPINDLE			
67	99501062	1/2-13 X 1 1/4" HEX CAP SCREW GR 8	2
41	99503014	1/2 SAE FLAT WASHER GR8	2
68	99501075	1/2-13 X 1 1/4" FHSCS GR8	4
69	99503017	1/2" MIL SPEC WASHER, (OPTIONAL SHIM)	6
SHIM PACK (Not Shown)			
-	99623005	5/8 MIL SPEC WASHER (THICKNESS 0.013-0.019)	8
-	99623006	5/8 MIL SPEC WASHER (THICKNESS 0.028 - 0.036)	8

EXPLODED VIEWS UPPER & LOWER CONTROL ARMS

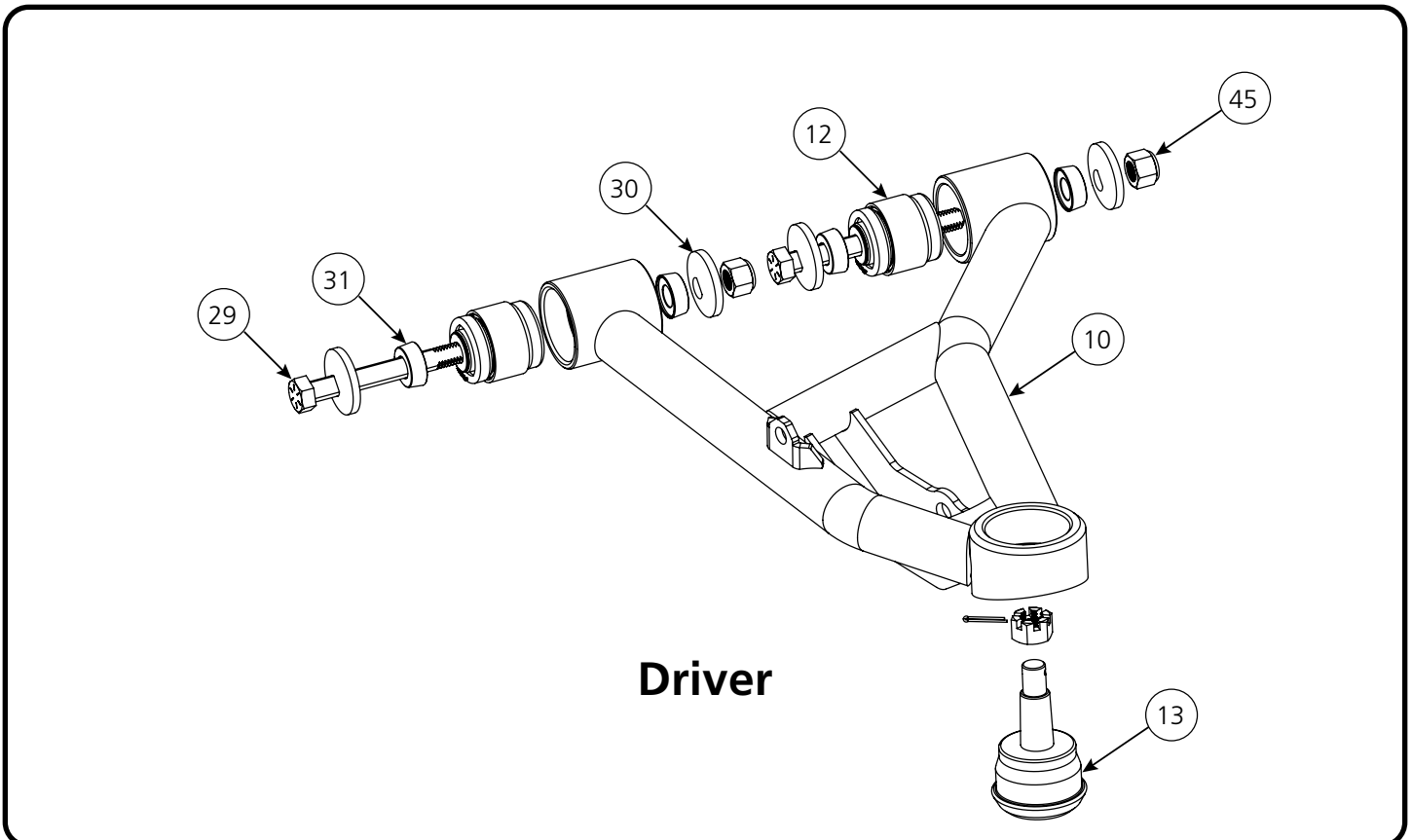
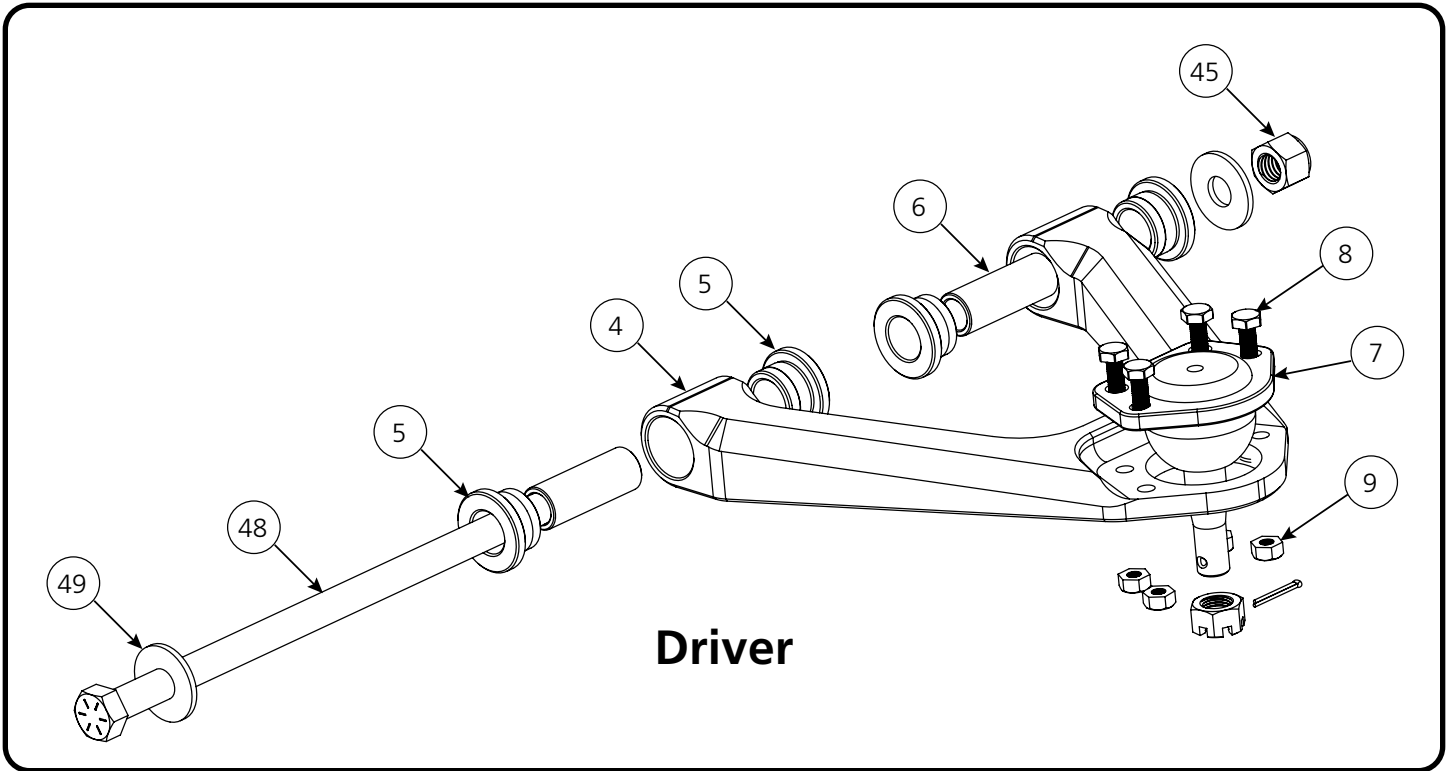

EXPLODED VIEWS FRONT SWAY BAR

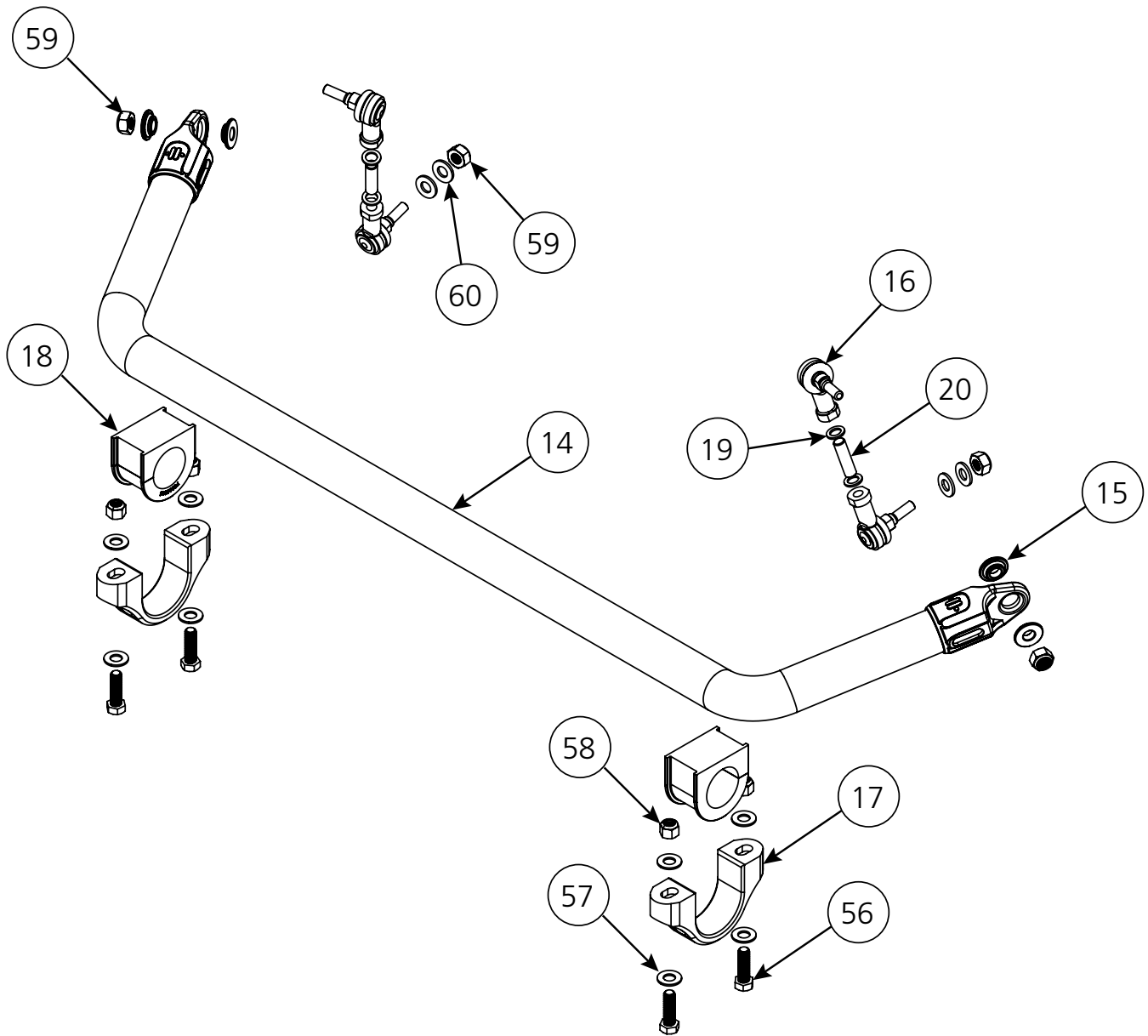

NOTE: The sway bar bushings in this kit contain an anti-friction lining. No lubrication is required.

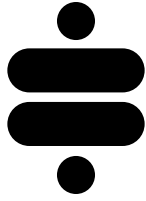

EXPLODED VIEWS HUB SPINDLE STEERING

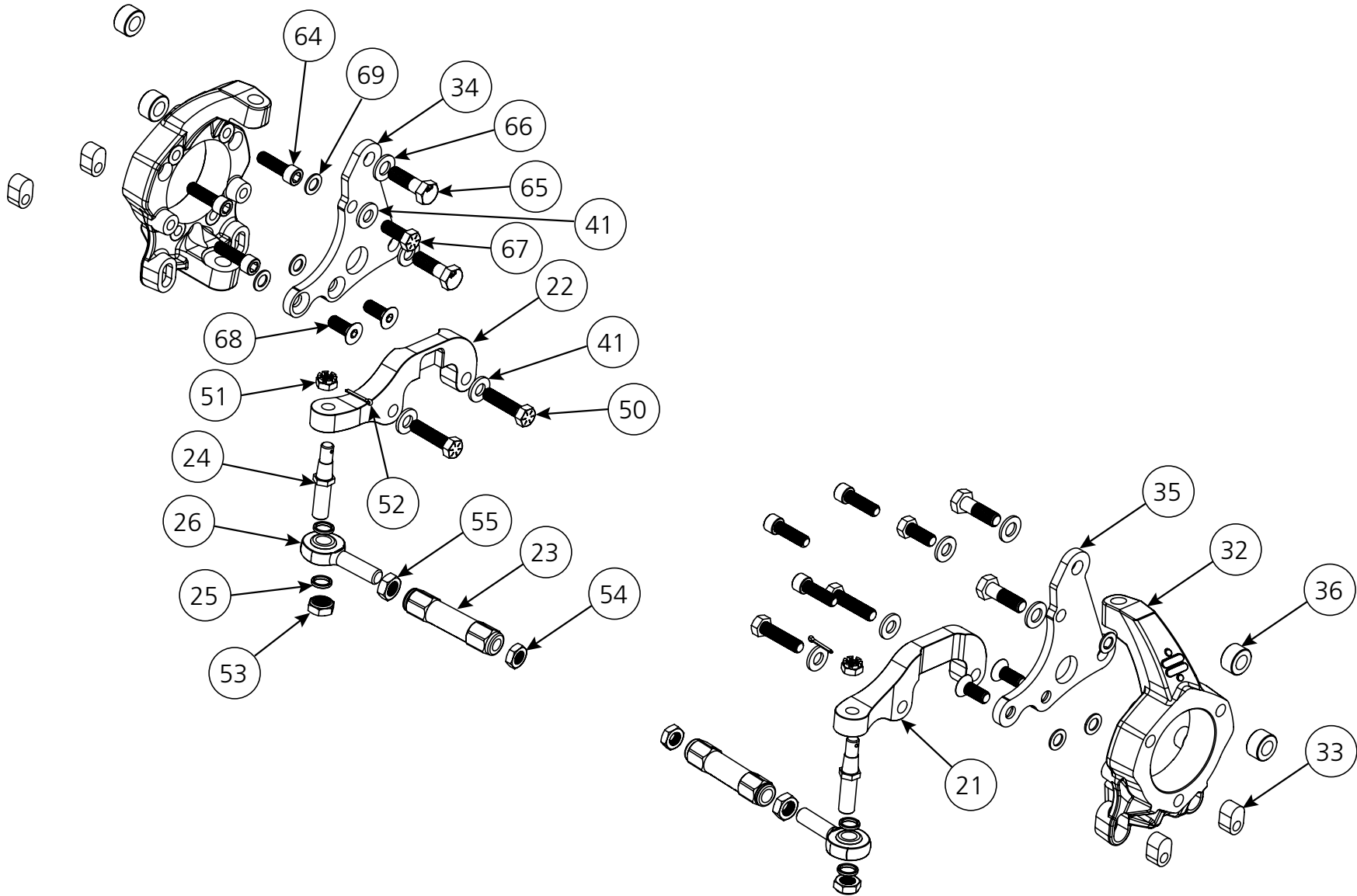

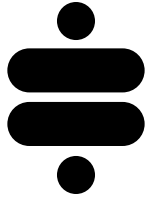

EXPLODED VIEWS "PIN" SPINDLE STEERING

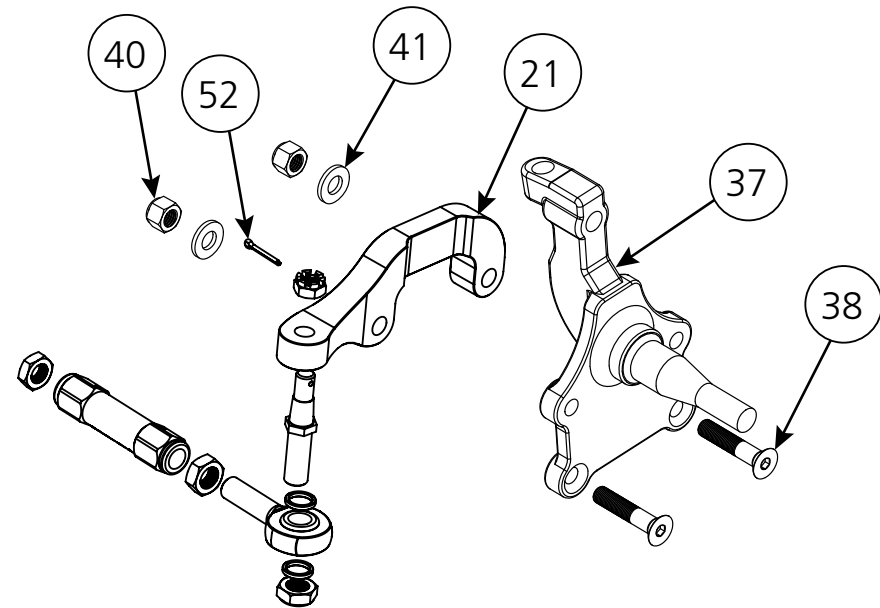
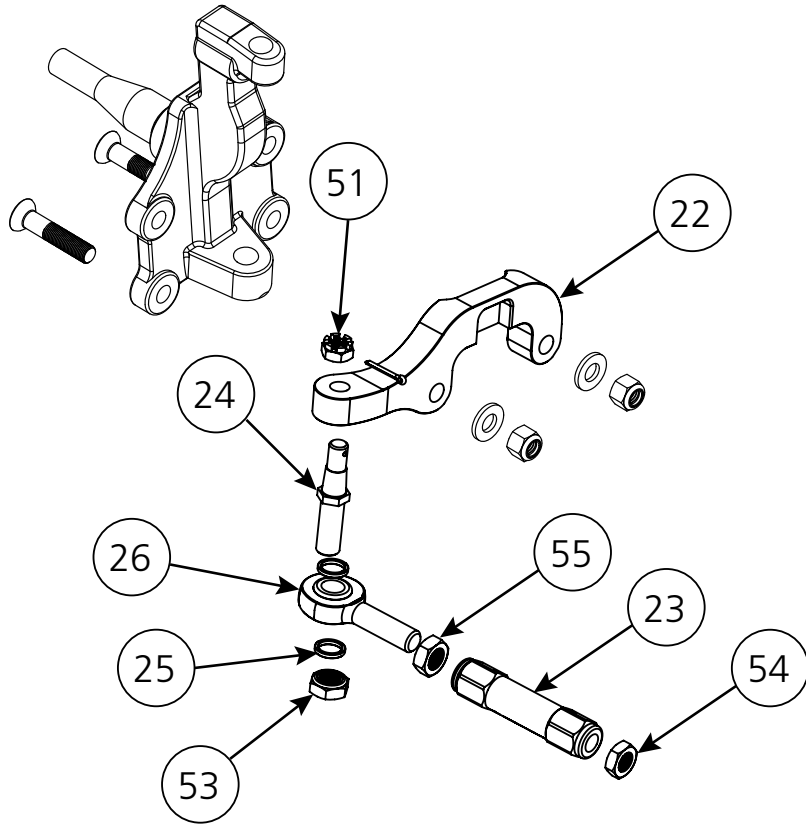

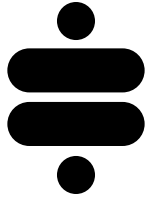

EXPLODED VIEWS

SUBFRAME, TRANSMISSION X-MEMBER

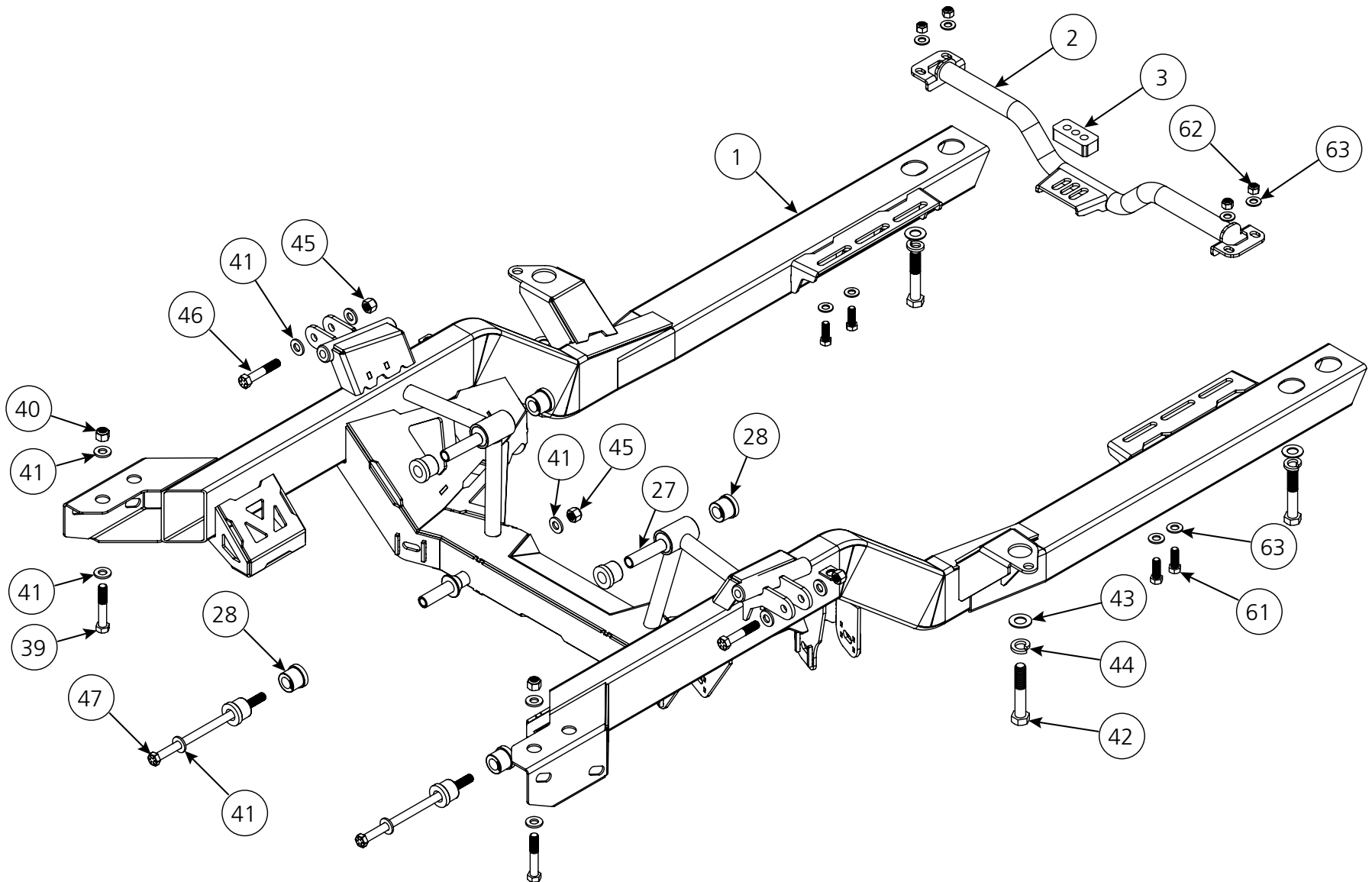

Disassembly

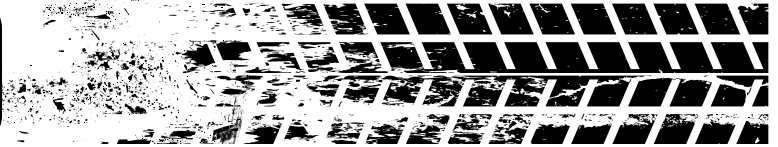

NOTE: If you would like your engine and transmission to be reinstalled in the same position on the new subframe, we recommend documenting the measurements listed below prior to beginning any disassembly.

Engine Position

Side-To-Side

Front-To-Back

*Measure from reference points on the car that will not change during the installation process.

Transmission Angle

A digital angle finder gauge works well for this.

1. Remove the engine, transmission, and existing subframe from the car. It may be beneficial to take a handful of photos before disconnecting harnesses, hoses, etc. These photos may be useful during reassembly. Also take note of any body-mount shims and at which locations they were used. They may be needed upon reassembly to re-establish body alignment.

NOTE: If you have access to a lift, you may not need to remove the engine and transmission separately from the existing subframe. We were able to remove the engine/transmission and subframe as an assembly as shown in Figures 1 and 2 below.

If you do not have access to a lift, you will most likely have to remove the engine and transmission prior to removing the existing subframe.



Figure 1



Figure 2

Upper Control Arms

2. Position a billet upper control arm onto the mounting flange of the new subframe (Figure 3).

Note: The upper control arms are not side specific.

3. Align the bushing holes of the arm with the holes in the mounting flange and install a 1/2"-13 x 11" bolt with 1/2" flat washer (Figure 4).

4. Install a 1/2" flat washer and 1/2"-13 nylok nut on the threaded end of the bolt (Figure 5).

Torque to **75 ft-lbs.**

5. Repeat steps 2-4 on the opposite side.



Figure 3



Figure 4



Figure 5

Engine Mount Bushings

6. Insert a 90002672 bushing sleeve into one of the 70015348 poly bushings. Slide the combo into one of the engine mount arm sleeves, and install another poly bushing into the opposite side of the arm sleeve (Figure 6).

The smaller OD end of the poly bushing slides into the arm sleeve.

7. Tap the bushing sleeve into the poly bushings until it is flush with the face of the poly bushing. You may have to hold the poly bushing on the opposite end so it does not push out (Figure 7).

8. Use some type of clamping tool to ensure the poly bushings and sleeves are fully seated in the engine mount arm sleeve (Figure 8).

A C-Clamp Vice Grip works well for this.

9. Repeat on the other engine mount arm.



Figure 6



Figure 7

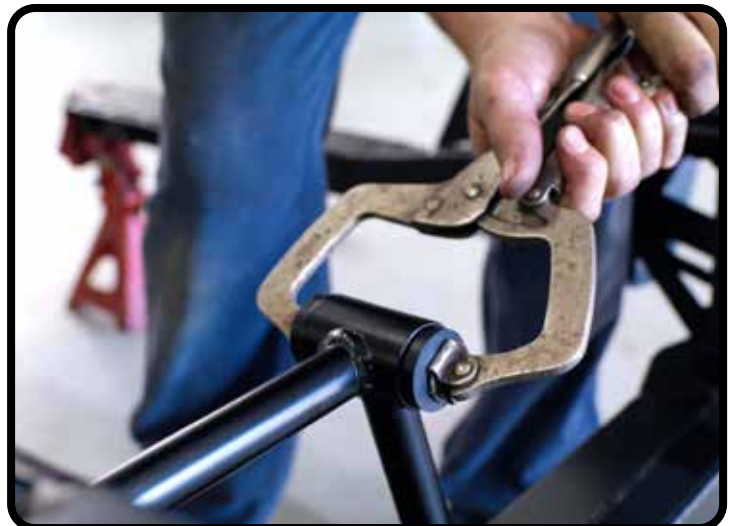

Figure 8

Lower Control Arms

10. Snap a 90003881 spacer onto each end of each of the lower control arm bushings (Figure 9).

Quick Tip: The spacers should snap onto the ends of the bushings, but some may not hold as tight as others. If the spacers fall off, try adding a dab of petroleum jelly or grease to the back of the spacers to help hold them in place while you are positioning the arm.

11. Position the lower control arm in the mounting flanges on the subframe. The sway bar end link mounting tab on the arm should be to the front (Figure 10).

12. Once all holes are aligned, install a 1/2"-13 x 4.5" eccentric bolt with eccentric washer through each mounting flange and bushing (Figure 11).



Figure 9



Figure 10



Figure 11

Lower Control Arms

13. Install an eccentric washer followed by a 1/2" nylok nut on the threaded end of each mounting bolt (Figure 12).

14. Before tightening the mounting bolts/nuts, ensure all of the eccentrics have matching orientation (Figure 13). Centering the bolt between the tabs on the mounting flange is a good place to start. Final adjustments will be made during the wheel alignment.

15. Torque to **75 ft-lbs.**

16. Repeat steps 11-15 on the opposite side.

NOTE: This is a good time to install your Ridetech Coilovers or Shockwaves. The mounting hardware is included in this kit (99010277). Torque the upper and lower mounting bolts to **75 ft-lbs.** The bearing spacers are included with the Coilover or Shockwave kit. Refer to the instructions included with your shock kit for additional details.

IMPORTANT: The upper shock mount bolts need to be installed with the threaded end of the bolt pointing to the rear of the vehicle as shown in Figure SB-1.



Figure 12

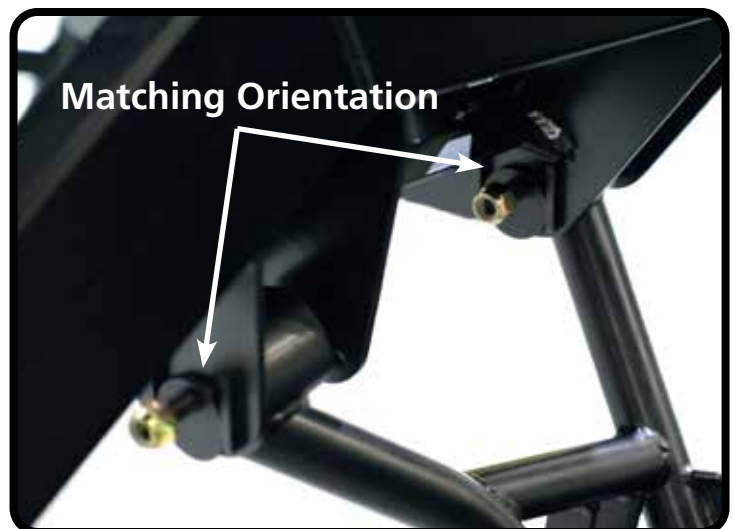

Figure 13



Figure SB-1

Steering Rack

17. This kit includes the hardware and poly bushings for mounting your steering rack (Figure 14).

The steering rack upgrade shown in the install photos is a PSC RA-33500 for a 79-93 Ford Mustang.

NOTE: Rack limiters may be necessary depending on your wheel & tire combination.

18. Press a 70015348 poly bushing into each side of your steering rack mounting flanges (Figure 15).

19. Once the bushings are installed, slide the steering rack onto the mounting posts on the new subframe (Figure 16).



Figure 14



Figure 15



Figure 16

Steering Rack

20. Install a 1/2"-13 x 9.5" bolt with 1/2" USS flat washer through each steering rack mounting post (Figure 17). A few light taps with a hammer might be required to fully seat the bolts.

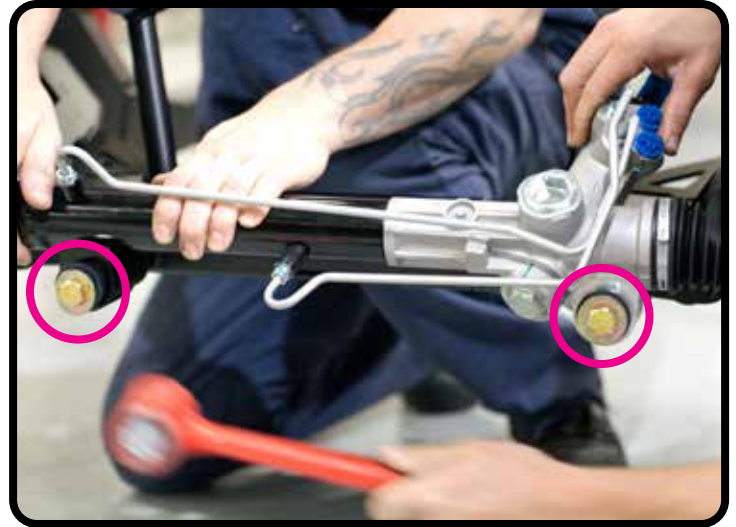

Figure 17

21. Install a 1/2" washer and nylok nut on each bolt and torque to **75 ft-lbs** (Figure 18).



Figure 18

Option A. If you are using a lift and wish to install the engine/transmission and new subframe into the vehicle as an assembly, this is a good time to transfer your engine and transmission onto the new subframe. Once the transfer is complete, proceed to step 22 to install the transmission cross member. Do not forget to provide support for the transmission until the cross member is in place.

NOTE: We recommend not tightening the engine mount bolts until the entire assembly is in the vehicle and the engine is positioned where you want it.

Option B. If you do not have access to a lift and/or need to install the engine and transmission separately after the new subframe is already installed in the vehicle, skip to Subframe Installation on page 32. Once the subframe is installed, you may circle back to Transmission X-Member or Spindle/Hub Assembly, depending on when you choose to install your engine & transmission.

Transmission X-Member

22. Position the transmission cross member onto the set of mounting slots on the subframe that aligns with the support flange on your transmission.

23. Bolt your transmission to the support plate on the transmission cross member. We recommend leaving the bolts hand tight until you have fine tuned the engine/transmission position in the vehicle.

NOTE: This cross member was designed to be used with the Energy Suspension 3.1108G transmission mount (Figure 20).

If you have something other than a T56 transmission, an optional spacer block (90003890) is included with this kit to help minimize the number of shims you may have to use. This spacer block should be used in conjunction with the Energy Suspension mount.

24. Attach the transmission cross member to the subframe with two 7/16"-14 x 1.25" bolts with washers on each side, secured with a 7/16" washer and nylok nut on each bolt.

We recommend leaving the bolts hand tight until you have fine tuned the engine/transmission position in the vehicle.

MUNCIE 4-SPEED: If you are using this transmission, you may encounter some minor interference with the floor pan. A simple remedy for this issue is to bolt the transmission mount to the bottom of the slotted mounting plates instead of resting on top of the plate.



Figure 19

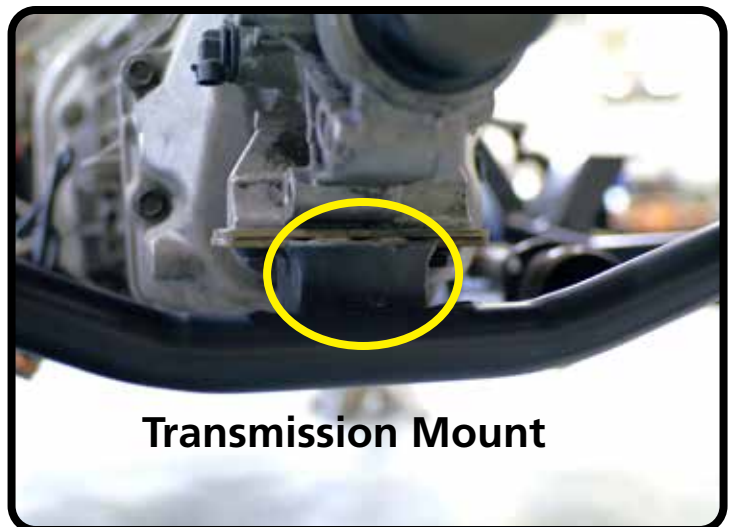

Transmission Mount

Figure 20



Figure 21

Spindle/Hub Assembly (11172798 Only)

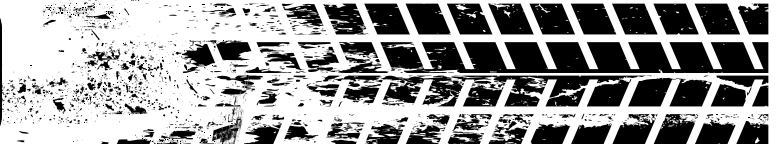

*** If you are installing the 11172799 "Pin" Spindle Subframe kit, you may skip steps 25-34 and jump to step PS1 on page 25. For the 11172798 Hub Spindle kit, continue to step 25 below.**

25. Position the Ridetech spindle onto the hub/bearing assembly and align the mounting holes in the hub/bearing assembly with the three countersunk holes in the spindle (Figure 22).

NOTE: The hub assemblies are purchased separately. The ridetech spindle is designed to be used with C5/C6/C7 Corvette hubs. If you do not require a speed sensor, we recommend using C7 hubs. They are stronger and more cost effective. We used Moog 513378 hub assemblies.

26. Apply Loctite to (3) M12-1.75 x 40mm socket-head bolts from the 99010230 hardware kit (Figure 23).

27. Install the three socket-head bolts to attach the spindle to the hub (Figure 24).

Tighten the bolts and torque to **99 ft-lbs.**

Repeat for the other hub & spindle.



Figure 22



Figure 23



Figure 24

Caliper Brackets (11172798 Only)

NOTE: We recommend mocking up the brake assembly with clean, dry threads before applying loctite to any threads and torquing for final assembly. See steps 61-62 for installing the caliper mount.

28. Position the caliper bracket on the back side of the spindle. The raised boss on the spindle should align with the large hole in the bracket, and the countersunk holes on the bottom side of the bracket should align with the mounting holes in the spindle (Figure 25).

29. Insert a 1/2"-13 x 1.25" flat-head bolt into each of the countersunk holes on the bracket (Figure 26).

30. Insert a 1/2"-13 x 1.25" hex bolt into the upper mounting hole on the caliper bracket (Figure 27).

Torque the hardware to **90 ft-lbs.**

Repeat on the other spindle.



Figure 25



Figure 26



Figure 27

Steering Arms (11172798)

NOTE: If you choose to torque the lower ball joint nut to the specified torque value in Step 36, we recommend not attaching the steering arms until the spindle is installed and the nut is torqued. A socket will not fit on the lower ball joint nut once the steering arm is attached.

31. Insert a 90003535 threaded insert into each of the recessed openings at the bottom of the hub side of the spindle (Figure 28).

The inserts should be oriented with the threaded hole toward the bottom of the spindle.

32. Apply Loctite to two 1/2"-13 x 2" hex bolts and slide a 1/2" washer onto each bolt.

33. While holding the threaded inserts in place, flip the spindle over and align the holes in the steering arm with the holes in the threaded inserts.

The arm should curve toward the hub (outboard) side of the spindle (Figure 29).

34. Insert a 1/2"-13 bolt with washer into each of the steering arm holes and thread into the inserts (Figure 30).

Torque to **90 ft-lbs.**

Repeat on the other spindle.



Figure 28

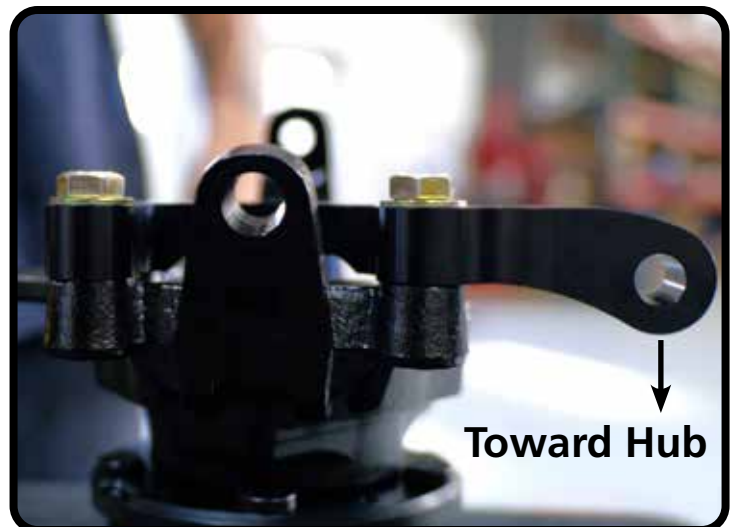

Figure 29



Figure 30

Steering Arms (11172799)

NOTE: If you choose to torque the lower ball joint nut to the specified torque value in Step 36, we recommend not attaching the steering arms until the spindle is installed and the nut is torqued. A socket will not fit on the lower ball joint nut once the steering arm is attached.

PS1. From the "pin" side of the spindle, insert a 1/2" - 20 x 2.5" flat-head bolt into each of the two lowest holes on the spindle as shown in Figure PS1.

PS2. Rotate the spindle to the back side and slide the steering arm onto the 1/2" bolts.

The arm should curve toward the "pin" (outboard) side of the spindle (Figure PS2).

PS3. Install a 1/2" washer and nylok nut onto each of the steering arm bolts (Figure PS3).

Torque to **100 ft-lbs.**

Repeat on the other spindle.



Figure PS1

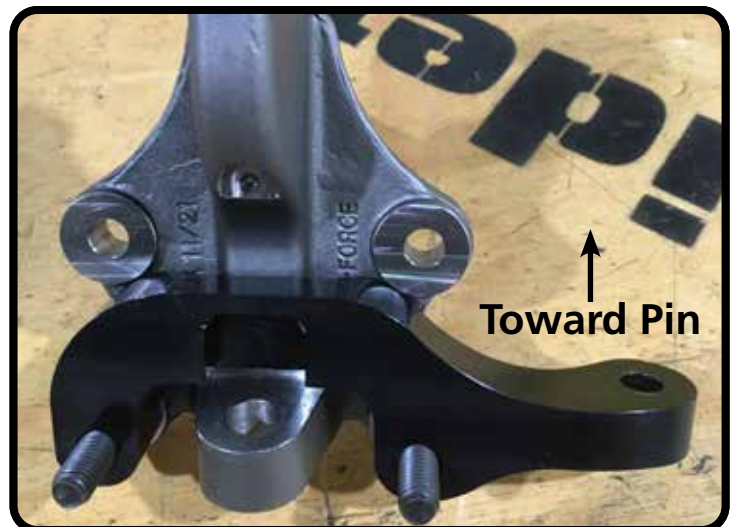

Figure PS2



Figure PS3

Spindle Installation

35. Position the spindle assembly onto the lower control arm ball joint. The curved portion of the steering arm should be to the front of the car.

Thread the castle nut onto the lower ball joint but do not tighten yet (Figure 31).

36. Pull the upper control arm down and insert the upper ball joint stud into the top of the spindle (Figure 32).

Thread the castle nut onto the upper ball joint and torque to **50 ft-lbs**.

If necessary, tighten the nut to line up the cotter pin holes. Install and bend the cotter pin (Figure 33).

Torque the lower ball joint nut to **65 ft-lbs**.

If necessary, tighten the nut to line up the cotter pin holes. Install and bend the cotter pin.

37. Repeat steps 35-36 on the opposite side.



Figure 31



Figure 32



Figure 33

Steering Assembly

38. Pull a 9/16"-18 jam nut from the 99010277 hardware kit "Steering" pack and thread onto the rod of the steering rack. Follow the nut with a 90003400 tie rod adjuster (Figure 34).

NOTE: The tie rod adjuster has both left-hand and right-hand threads. The grooved end of the adjuster has the left-hand threads (Figure 36). We recommend applying anti-seize to the threads at each end of the tie rod adjuster.

39. Thread a 5/8"-18 LH thread jam nut onto a 90001582 Heim end. Then thread the Heim end into the grooved end (LH thread) of the tie rod adjuster (Figure 35).

NOTE: Use the sight holes at each end of the tie rod adjusters to ensure you have sufficient thread engagement (Figure 36). You should be able to see at least one or two threads in each sight hole for adequate engagement.

Leave the jam nuts loose for now. They will be tightened during wheel alignment.



Figure 34



Figure 35



Figure 36

Steering Assembly

40. Insert the tapered end of a 90003883 tie rod stud into the end of the steering arm from the bottom (Figure 37).

41. From the 99010277 hardware kit "Steering" pack, thread a 1/2"-20 castle nut onto the top threads of the stud and torque to **35 ft-lbs**. Then insert and bend the cotter pin (Figure 38).

It may be necessary to tighten the nut a bit more to line up the cotter pin holes.

42. Install a 90002676 spacer on the lower end of the tie rod stud (Figure 39).

43. Slide the Heim end onto the stud, followed by another 90002676 spacer, and finally a 5/8"-18 thin nylok nut (Figure 40).

Torque the 5/8" nylok nut to **45 ft-lbs**.

44. Repeat steps 38-43 on the opposite side.



Figure 37



Figure 38

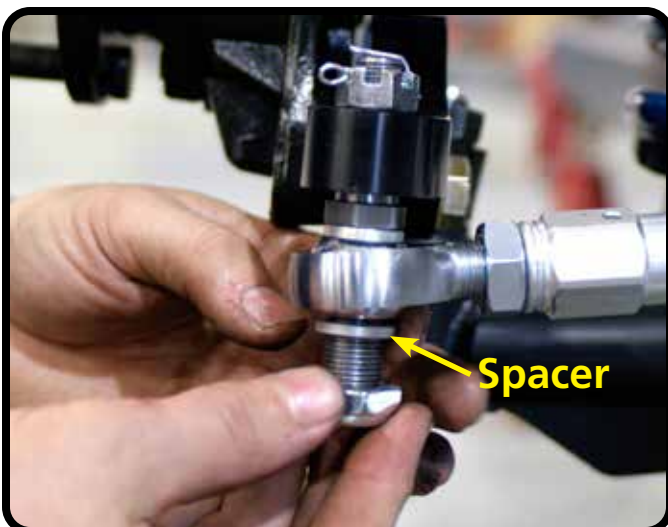

Figure 40



Figure 39

Front Sway Bar

45. This subframe kit includes a new front sway bar. The sway bar may be installed with the subframe either on or off of the vehicle.

Gather all components shown in Figure 37. You will need the included hardware kit# 99010278.

46. Spread open each of the 70015016 bushings at the split and install onto the sway bar. Position each bushing approximately a few inches inboard of the bend at each end (Figure 38).

NOTE: The bushings in this kit contain an anti-friction lining. No lubrication is required.

47. Slide a billet mounting strap over each bushing (Figure 39).



Figure 37

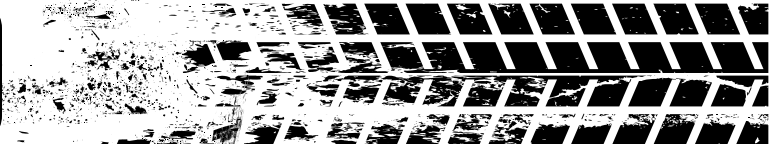

Figure 38



Figure 39

Front Sway Bar



48. Place a 3/8" flat washer on each of (4) 3/8"-16 x 1.25" bolts. Position the bar under the front of the subframe, aligning the mounting straps with the holes in the mounting flanges on the bottom of the subframe rails.

Insert a 3/8" bolt with washer into each of the billet strap mounting holes and secure with a 3/8" washer and nylok nut on each bolt (Figure 40). You may leave them hand tight for now to allow for easy bar articulation while installing the end links.



Figure 40

49. Slide a 90001258 adapter bushing onto one of the end link studs. The larger OD, flat side of the bushing should face toward the 90-degree end link as shown in Figure 41.



Figure 41

50. With the adapter bushing installed on the end-link stud, insert the stud into the sway bar eyelet from the inboard side as shown in Figure 42.



Figure 42

Front Sway Bar

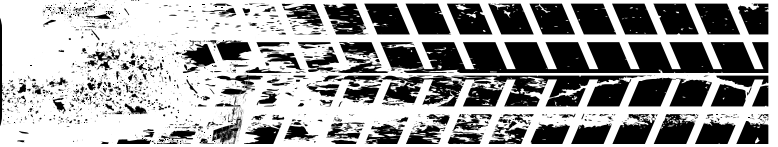

51. Slide another 90001258 adapter bushing onto the end-link stud, this time with the small OD side of the bushing facing toward the bar eyelet. Then install an M10 nylok nut (Figure 43).



Figure 43

52. Slide a 3/8" flat washer onto the lower stud of the end link. Then insert the stud into the mounting tab on the lower control arm (Figure 44).



Figure 44

53. Slide another 3/8" flat washer onto the end-link stud, followed by an M10 nylok nut (Figure 45).
Torque the M10 nuts to **49 ft-lbs.**

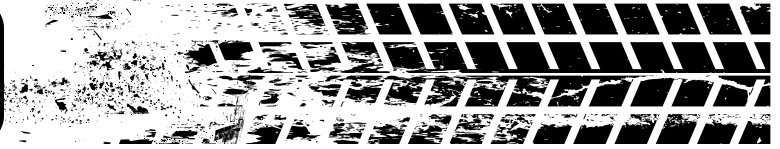

Figure 45

54. Repeat steps 49-53 on the opposite side.

55. Once the end links are installed, tighten the sway bar mounting straps bolts/nuts and torque to **32 ft-lbs.**

Subframe Installation



56. Position the new subframe under the vehicle and align the six mounting locations on the subframe with their corresponding locations on the body. There are indexing holes on the mounting flanges at location B that should align with matching holes on the body (See detail B1 below).

NOTE: This step may be completed with or without the engine and transmission mounted in the subframe. This is also a good time to replace or upgrade your subframe bushings if necessary.

57. From the 99010277 hardware kit "Subframe To Car" packet, slide a 1/2" flat washer on each of the two 1/2"-20 x 3" bolts. Insert a 1/2" bolt with washer in each of the two "A" mounting locations. Secure with a 1/2" flat washer and nylok nut on each bolt. Do not tighten until the remaining four mounting bolts at locations B and C or D are installed.

58. Slide a 5/8" split lock washer followed by a 5/8" flat washer onto each of the four 5/8"-11 x 3.5" bolts. Thread a 5/8" bolt with washers into the body at each of the four B & C or D mounting locations shown below. **Use holes "C" for '74-'81. Use holes "D" for '70-'73.**

Torque bolts "A" to **30-40 ft-lbs.**

Torque bolts "B" & "C" or "D" to **75-90 ft-lbs.**

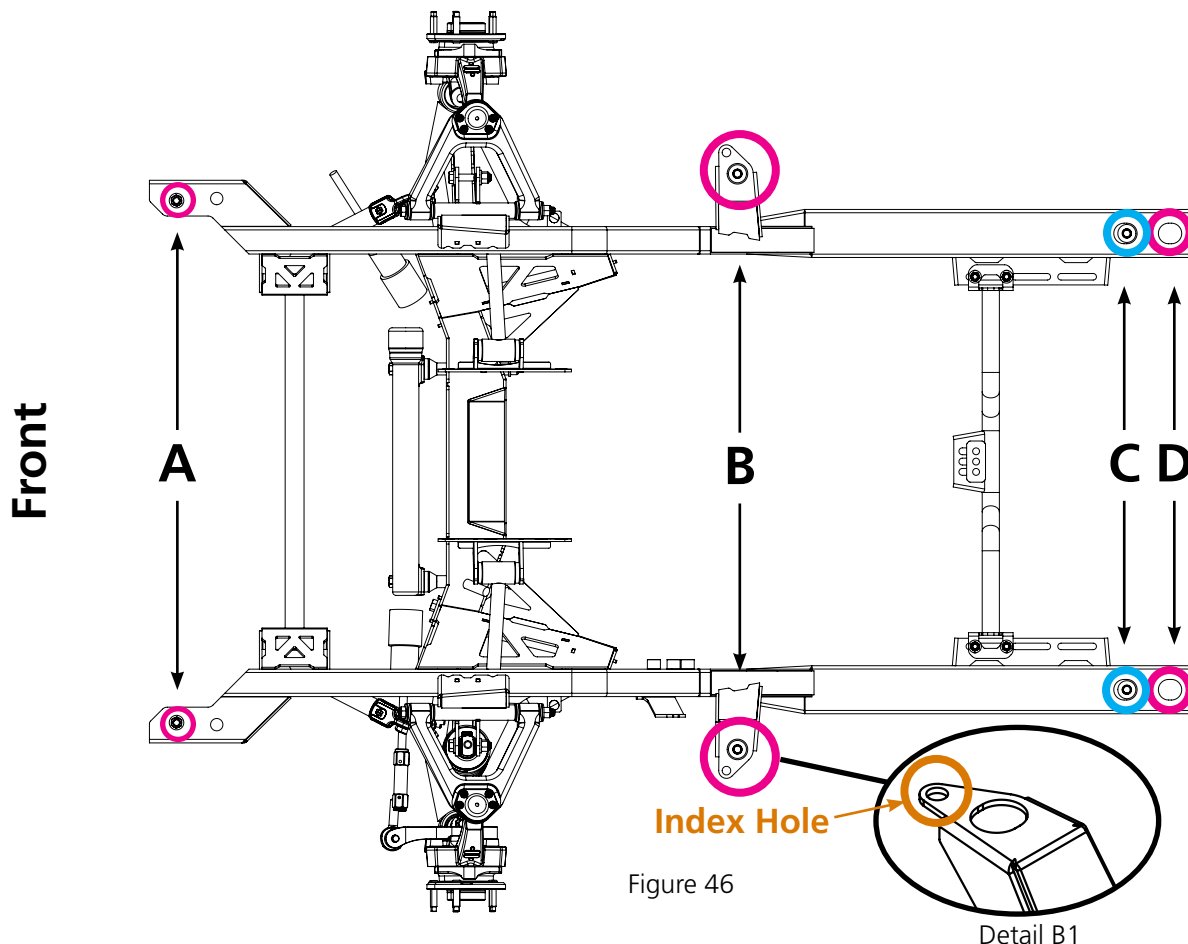

Figure 46

Detail B1

Final Assembly

59. With the subframe, engine and transmission installed in the vehicle, make any final adjustments to the position of the engine/transmission. Once satisfied, tighten the four 7/16" Transmission X-Member bolts (Figure 47). Torque to **45 ft-lbs**.

Do not forget to also tighten the engine mount bolts.

60. Reinstall/reattach the driveshaft, engine accessories, lines, hoses, wiring harnesses, etc.

61. Finish installing the brakes. Install the brake rotor and temporarily secure with a couple of lug nuts (Figure 48).

62. (11172798 Only) Mount the brake caliper mount to the caliper bracket with (2) M14-2.0 x 45mm bolts and M14 washers. Insert a 90003549 spacer on each bolt, between the caliper bracket and the caliper mount (Figure 49). Torque to **125 ft-lbs**.

63. Install the brake calipers and pads.

64. Finish plumbing and bleeding the system.

NOTE (11172798): This kit includes a set of shims to aid in centering the caliper mount on the rotor. The provided shims are in three different thicknesses (.016", .032", .063").

- To push the caliper mount outward, insert 5/8" shim washers between the caliper and the caliper bracket.
- To pull the caliper mount inward, insert 1/2" shim washers on the bolts from steps 29 & 30, between the caliper bracket and the spindle.

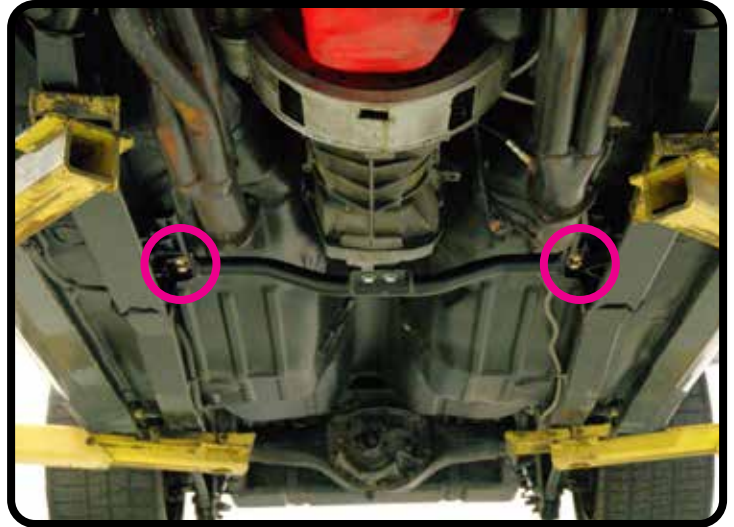

Figure 47



Figure 48

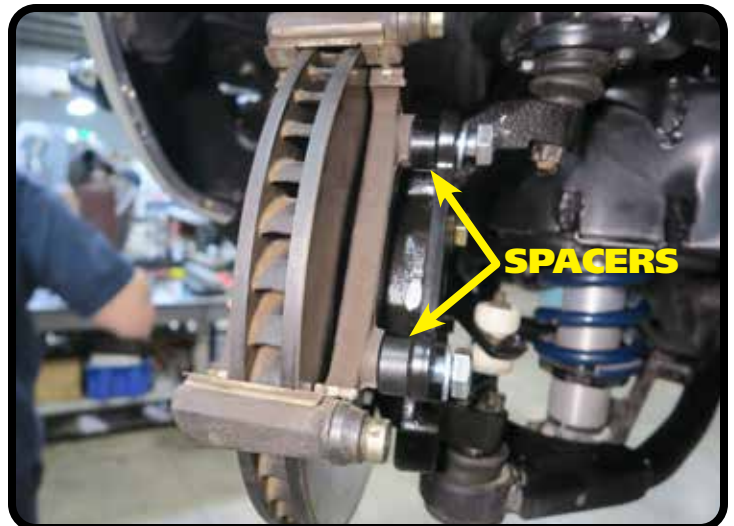
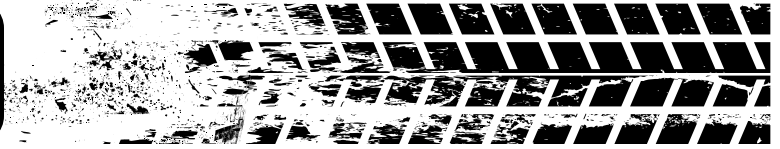

Figure 49

Final Assembly



65. Reinstall the hood, bumper, wheels/tires, etc. Then set the vehicle on the ground.
66. If you're running coilovers, adjust and set your ride height. See the "Adjusting Ride Height Guide" in your coilover instructions.

If you're on air, finish plumbing and testing the system.

67. Have the vehicle aligned. See the recommended alignment specs below.

Suggested Alignment Specs For Street Driving

Camber: -.5 Degrees

Caster: +5.5 to +7.5 Degrees

Toe: 1/16" - 1/8" Toe In