

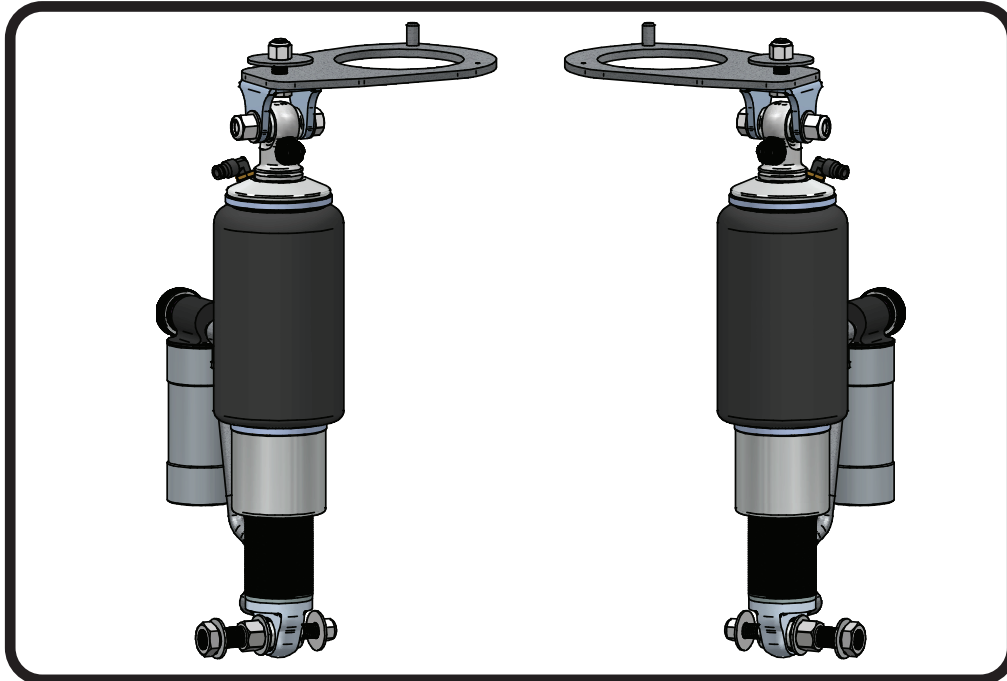

**Part # 11215411 - 1982-2002 GM F-Body Rear Shockwave**

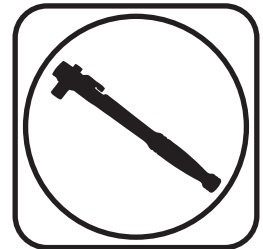

Recommended Tools



## 82-02 F-Body TQ Series Rear Shockwave Installation Instructions

### Table of contents

Page 2.....	Included Components
Page 3.....	Hardware List and Getting Started
Page 4.....	ShockWave installation
Page 5.....	ShockWave Installation and Notes and Care
Page 6.....	Care of your Shockwaves
Page 7.....	Shock Adjustment
Page 8.....	Shock Adjustment





### Major Components .....In the box

Item #	Part #	Description	QTY
1	986-10-072	5.2" Stroke TQ Series Shock	2
2	234-00-153	AirSpring Locking Ring	2
3	31954201	1/4" NPT to 1/4" Tube Swivel 90 Air Fitting	2
4	24190799	7000 Series 4" Diameter Air Spring	2
5	90002067	5/8" ID Lower Bearing Spacers	4
6	90001617	Lower ShockWave Mounting Stud with hardware	2
7	815-05-022	Shock Eyelet	2
8	90001994	5/8" ID Bearing (installed in shock and eyelet)	4
9	90001995	Bearing Snap Ring (installed in shock and eyelet)	8
10	90002043	1/2" ID Upper Bearing Spacers	4
11	90000034	Upper ShockWave Mount	2
12	90002150	Driver Upper Plate	1
12	90002151	Passenger Upper Plate	1
	026-05-000	Reservoir Mounts (Not Shown)	4
	85000003	Reservoir Mount Allen Wrench (Not Shown)	1

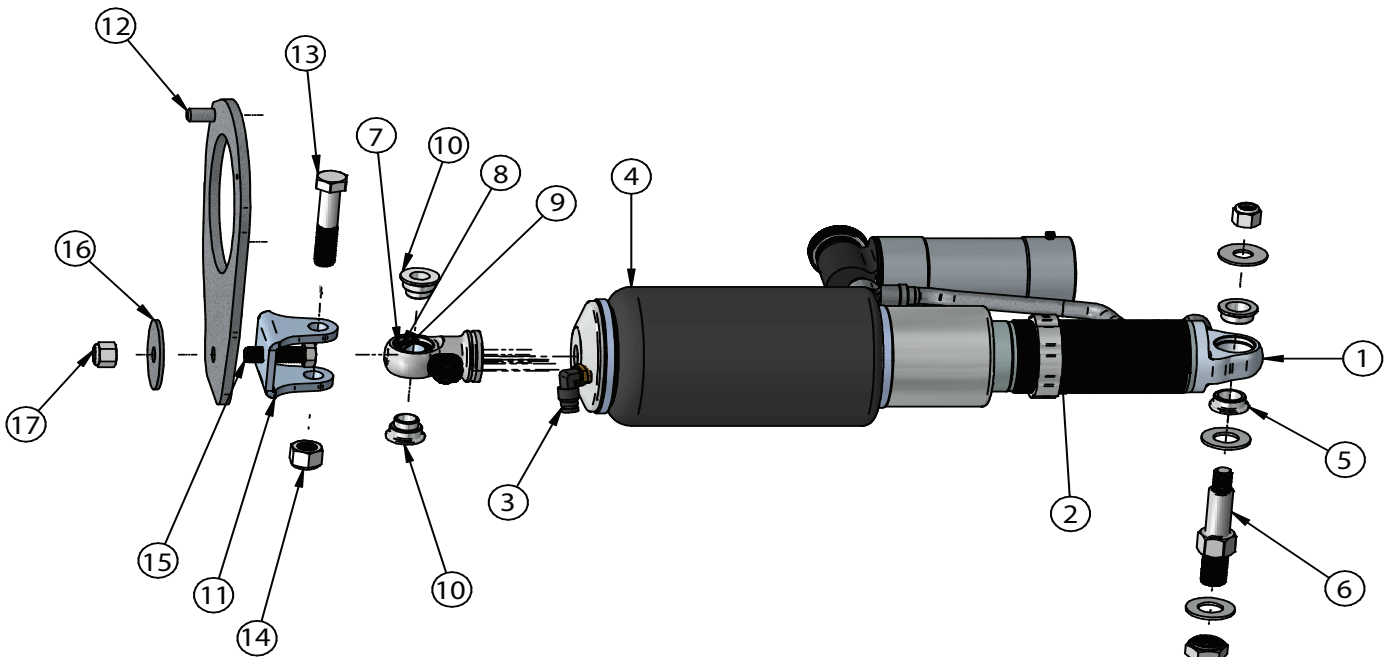



### Hardware List .....In the box

Item #	QTY	Part Number	Description	Location
13	2	99501003	1/2"-13 x 2 1/2" Bolt	Upper ShockWave to Mount
14	2	99502001	1/2"-13 Nylok Nut	Upper ShockWave to Mount
15	2	99431008	7/16"-14 x 1 1/2" Bolt	Upper Mount to Car Body
16	2	99432001	7/16"-14 Nylok Nut	Upper Mount to Car Body
17	2	99433001	7/16" x 2" Washer	Upper Mount to Car Body
	12	99055000	5mm SHCS	Reservoir Mounts (Not Shown)

### Getting Started.....

Congratulations on your purchase of the Ridetech Rear ShockWave System. This system has been designed to give your car excellent handling along with a lifetime of enjoyment. One of the key features of this system is the adjustability. With the ShockWave system you have an adjustable shock along with the height adjustment of the airspring.

### Disassembly

1. The rear springs, shocks and bumpstops will need to be removed from the car.
2. With the car on a lift or jack stands, support the rear differential with a jack and disconnect the bottom of the shock from its mount on the rear differential.
3. With the shock disconnected, **slowly** lower the rear differential until the rear spring comes loose. **Pay attention to the brake hose so that you don't pull it apart.** Remove the springs from the car.
4. The carpet in the hatch area right behind the set will have to be pulled back to gain access to the top of the shock. The top of the shock is located right behind the back seat. There is a piece of foam that covers the top of the shock.

**NOTE:** Keep in mind the spring has pressure on it until you let the rear differential down to remove the springs.



### ShockWave Installation

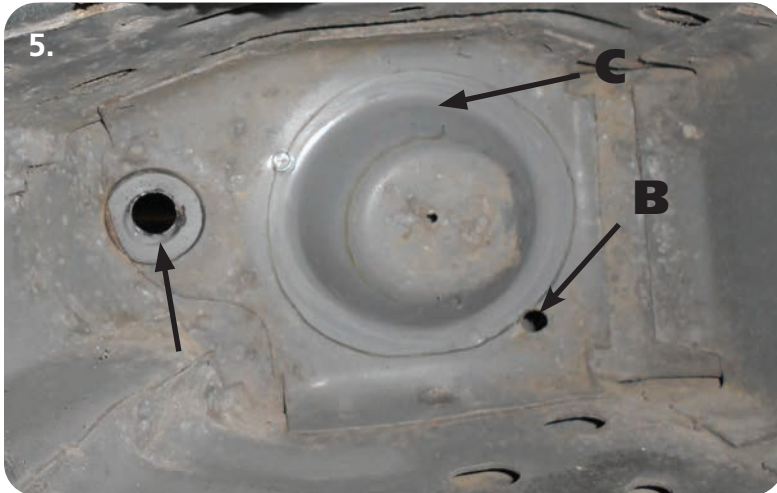

5. Picture "5" shows the factory upper coil-spring pocket in the car. (A) is the factory shock hole that the upper plate and mounting bracket will be bolted through, (B) is a locating hole in the body that will be used to help locate the new upper plate, (C) is the factory coil spring locator that will also help in locating the upper plate

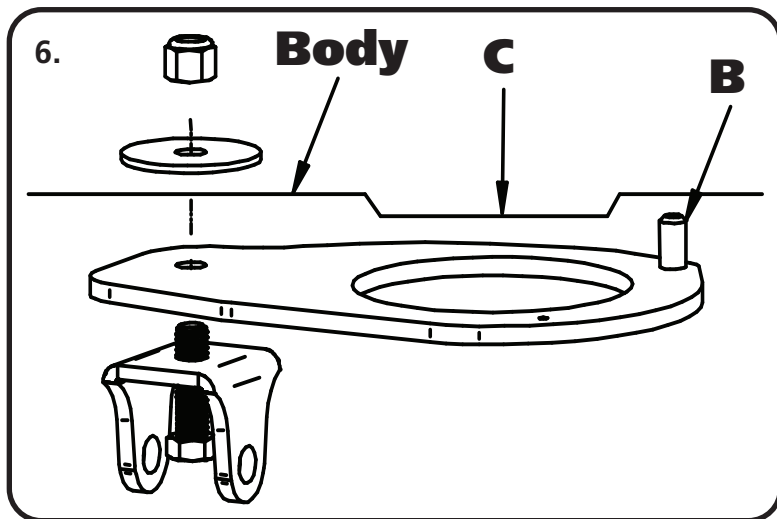

6. **This step is a 2 person job.** The upper plate and ShockWave mount get bolted in the car using (1) 7/16" x 1 1/2" bolt, the large flat-washer and Nylok nut. Place the 7/16" bolt through the Upper mount and plate. Place the upper plate up into the factory coil spring pocket with the locating pin (B) going into the small hole. Put the 7/16" bolt through the Upper Mount and then insert it into the hole location at the factory shock hole. Have the person helping install the Large 7/16" washer and Nylok nut on the bolt from inside the vehicle.



7. Tighten the 7/16" Nut and bolt with the help of the second person. When tightening be sure the upper mount is clocked in a manner that the upper ShockWave mounting bolt will be in line with the lower stud.

**Note:** The purpose of the upper plate is to distribute the load of the ShockWave over a larger area.



### ShockWave Installation

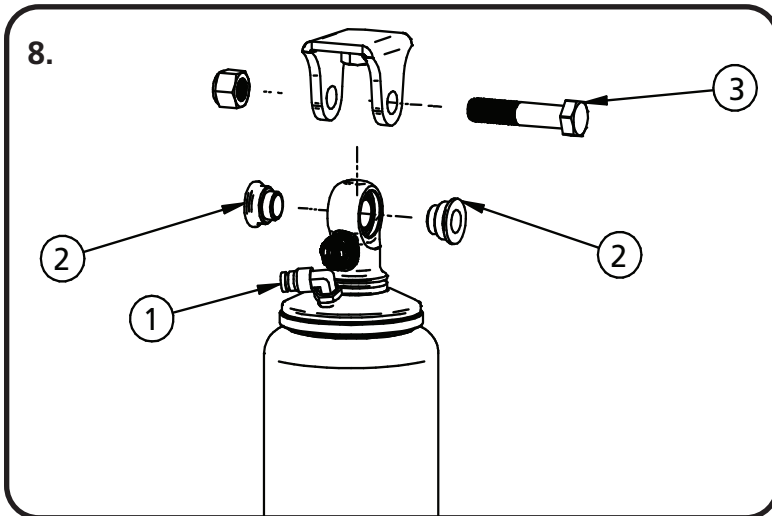

8. Install the 90 degree Air fitting (1) into the Shockwave using Teflon tape or some form of thread sealant on the threads. Install the 1/2" I.D. Spacers (2) into the bearing of the upper ShockWave eyelet. Insert the ShockWave into the upper mounting bracket aligning the holes in the spacers with the holes in the bracket. Insert 1/2" x 2 1/2" bolt (3) through the bracket and CoilOver. Install 1/2" Nylok nut and tighten.

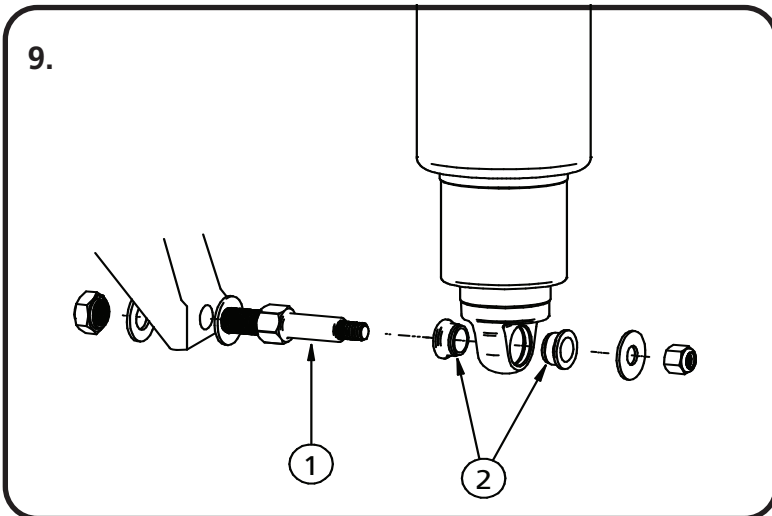

9. Drill the factory shock stud hole out to 5/8", this can be done using a Unibit. Install the (1) Shock stud (90001617) into the factory lower mount using the hardware supplied with the stud. Install a 5/8" I.D. spacer on the shock stud, then the bottom of the ShockWave on the stud, followed by another 5/8" I.D. spacer. Install 7/16" washer and Nylok nut.

**Note:** It may be necessary to raise or lower the rear differential with the jack to get the lower shock bearing to line up with the stud.

### Notes and Care of your Shockwaves

#### NOTES:

You can clock the air fitting location on the ShockWave by turning the AirSpring assembly of the shock.

The threads on the fittings need to have thread sealant applied to seal properly.

When cutting the airline, use a razor blade. The cut needs to be a clean cut and square for the airline to seal properly.

**The Locking ring on the shock is NOT adjustable. These rings are set at the factory to optimize the AirSpring stroke with the shock stroke.**



### Care of your ShockWaves

## The care and feeding of your new ShockWaves

1. Although the ShockWave has an internal bumpstop, **DO NOT DRIVE THE VEHICLE DEFLATED RESTING ON THIS BUMPSTOP. DAMAGE WILL RESULT.** The internal bumpstop will be damaged, the shock bushings will be damaged, and the vehicle shock mounting points may be damaged to the point of failure. This is a non warrantable situation.
2. Do not drive the vehicle overinflated or “topped out”. Over a period of time the shock valving will be damaged, possibly to the point of failure. This is a non warrantable situation! If you need to raise your vehicle higher than the ShockWave allows, you will need a longer unit.
3. The ShockWave is designed to give a great ride quality and to raise and lower the vehicle. **IT IS NOT MADE TO HOP OR JUMP!** If you want to hop or jump, hydraulics are a better choice. This abuse will result in bent piston rods, broken shock mounts, and destroyed bushings. This is a non warrantable situation.
4. Do not let the ShockWave bellows rub on anything. Failure will result. This is a non warrantable situation.
5. The ShockWave product has been field tested on numerous vehicles as well as subjected to many different stress tests to ensure that there are no leakage or durability problems. Failures have been nearly nonexistent unless abused as described above. If the Shockwave units are installed properly and are not abused, they will last many, many years. ShockWave units that are returned with broken mounts, bent piston rods, destroyed bumpstops or bushings, or abrasions on the bellows will not be warrantied.



### Shock Adjustment

#### Shock Adjustment 101- Single Adjustable

##### Rebound Adjustment:

How to adjust your new shocks.

The rebound adjustment knob is located on the top of the shock absorber protruding from the eyelet.

You must first begin at the ZERO setting, then set the shock to a soft setting of 20.



-Begin with the shocks adjusted to the ZERO rebound position (full stiff). Do this by rotating the rebound adjuster knob clockwise until it stops.



-Now turn the rebound adjuster knob counter clock wise 20 clicks. This sets the shock at 20. (settings 21-24 are typically too soft for street use).

##### Take the vehicle for a test drive.



-if you are satisfied with the ride quality, do not do anything, you are set!

-if the ride quality is too soft increase the damping effect by rotating the rebound knob clock wise 3 clicks.

##### Take the vehicle for another test drive.



-if the vehicle is too soft increase the damping effect by rotating the rebound knob clock wise 3 additional clicks.



-If the vehicle is too stiff rotate the rebound adjustment knob counter clock wise 2 clicks and you are set!

Take the vehicle for another test drive and repeat the above steps until the ride quality is satisfactory.

##### Note:

**One end of the vehicle will likely reach the desired setting before the other end. If this happens stop adjusting the satisfied end and keep adjusting the unsatisfied end until the overall ride quality is satisfactory.**



## Shock Adjustment

### Shock Adjustment 101-Triple Adjustable

#### Triple Adjustable:

#### Step One: High Speed Compression



- High speed compression adjustments are used in both street driving and track tuning.
- Begin with the shocks adjusted to the ZERO high speed compression position (full stiff). Do this by rotating the high speed compression adjuster (large knob) clockwise until it stops.
- Now turn the high speed compression adjuster knob counter clock wise 20 clicks. This sets the shock at 20. (settings 21-24 are typically too soft for street use. For typical street driving the high speed compression adjuster will remain at setting 20.

#### Step Two: Low Speed Compression

Low speed compression adjustment is what is typically felt during street driving.



- Begin with the shocks adjusted to the ZERO low speed compression position (full stiff). Do this by rotating the low speed compression adjuster (small knob) clockwise until it stops.
- Now turn the low speed compression adjuster knob counter clock wise 20 clicks. This sets the shock at 20. (settings 21-24 are typically too soft for street use). Take the vehicle for a test drive.
- if you are satisfied with the ride quality, do not do anything, you are set!
- if the ride quality is too soft increase the damping effect by rotating the low speed compression knob clock wise 3 clicks.

#### Take the vehicle for another test drive.



- if the vehicle is too soft increase the damping effect by rotating the low speed compression knob clock wise 3 additional clicks.
- If the vehicle is too stiff rotate the low speed compression adjustment knob counter clock wise 2 clicks and you are set!

Take the vehicle for another test drive and repeat the above steps until the ride quality is satisfactory.

#### Step 3:

Adjust rebound according to Single Adjustable instructions.

#### **Note:**

**One end of the vehicle will likely reach the desired setting before the other end. If this happens stop adjusting the satisfied end and keep adjusting the unsatisfied end until the overall ride quality is satisfactory.**