



350 S. St. Charles St. Jasper, In. 47546
Ph. 812.482.2932 Fax 812.634.6632

www.ridetech.com

Part # 11224010
64-72 GM "A" Body Rear CoolRide Kit

COOLRIDE KIT

Components:

2	90002018	91mm rolling sleeve air spring
2	90002284	Large cotter pin
2	90000504	Stud for cotter pin (screws into top of air spring)
2	90000709	Upper spring retainer washer (4" o.d. x .75" i.d.)
2	90000291	Lower spring retainer washer (2.5" o.d. x .5" i.d.)
2	90000548	Large lower air spring roll plate

Hardware:

2	99371003	3/8" x 1" USS bolt	Air spring to axle
2	99373003	3/8" SAE flat washer	Air spring to axle
2	99373005	3/8" lock washer	Air spring to axle

SHOCK KIT

Shock:

2	986-10-020	7.55" Stroke Eye Top Shock Cartridge
2	70011139	5/8" ID Shock Bushing
2	70011138	3/4" ID Shock Bushing
2	90002102	1/2" ID Shock Sleeve
2	90002068	Wide Trunnion

Components:

2	90001619	Shock stud
---	----------	------------

Hardware:

4	99311001	5/16" x 1" USS bolt	Shock to frame
8	99313002	5/16" SAE flat washer	Shock to frame
4	99312003	5/16" USS Nylok nut	Shock to frame

COOLRiDE®

CoolRide Installation Instructions

*****Must be used w/ RideTech shock kit*****

1. Raise and support vehicle at a safe and comfortable working height.
2. Support the axle then remove coil spring and shock. Refer to service manual for proper disassembly procedure. Installing one side at a time will make the installation easier.



3. Apply thread sealant to a 90 degree air fitting and screw it into the top of the air spring.
4. Screw the mounting pin into top of the air spring.



5. Place the 4" diameter washer on top of the frame, above the coil spring pocket. Raise the air spring up to the spring pocket with the pin sticking through the washer. Secure with the large cotter key.



6. Place the large lower air spring plate over the lower coil spring retainer.
7. Pull the piston down out of the air spring and seat it on the lower coil spring retainer. The center hub in the piston should fit inside the retainer.
8. Some retainers may require trimming to allow the air spring piston to slide into the retainer.



9. Secure the air spring to the axle using a 3/8" x 1" bolt, lock washer, flat washer, and the 2 1/2" washer.
10. Inflate the air spring and check air spring clearance. **If the spring is allowed to rub on anything it will cause failure, this is not a warrantable situation.**
14. This system will retain the factory bump stop.
15. Driving height on this air spring is approximately 8.5" tall, but may slightly vary to driver preference.

Shock Installation Instructions



1. Attach the upper T-bar to the frame in the oem location using the supplied 5/16 x 1" USS bolts, washers and Nylok nuts.

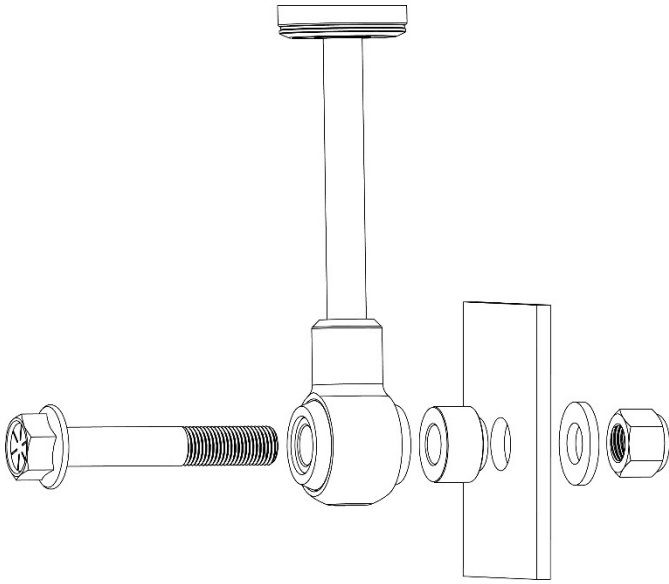

2. Attach the shock to the axle using the new shock bolt kit supplied.

Shock adjustment 101- Single Adjustable

Rebound Adjustment:

How to adjust your new shocks.

The rebound adjustment knob is located on the top of the shock absorber protruding from the eyelet or stud top. You must first begin at the ZERO setting, then set the shock to a street setting of 12.



-Begin with the shocks adjusted to the ZERO rebound position (full stiff). Do this by rotating the rebound adjuster knob clockwise until it stops.

-Now turn the rebound adjuster knob counter clock wise 12 clicks. This sets the shock at 12. (settings 21-24 are typically too soft for street use).

Take the vehicle for a test drive.

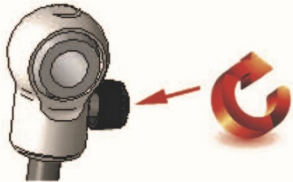

-if you are satisfied with the ride quality, do not do anything, you are set!

-if the ride quality is too soft increase the damping effect by rotating the rebound knob clock wise 3 clicks.

Take the vehicle for another test drive.

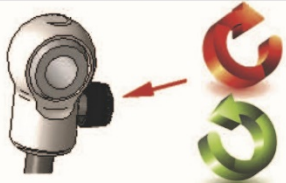

-if the vehicle is too soft increase the damping effect by rotating the rebound knob clock wise 3 additional clicks.

-If the vehicle is too stiff rotate the rebound adjustment knob counter clock wise 2 clicks and you are set!

Take the vehicle for another test drive and repeat the above steps until the ride quality is satisfactory.

Note:

One end of the vehicle will likely reach the desired setting before the other end. If this happens stop adjusting the satisfied end and keep adjusting the unsatisfied end until the overall ride quality is satisfactory.