

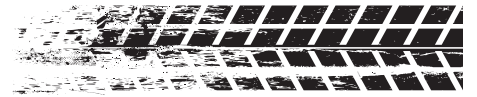

INSTALLATION INSTRUCTIONS



Part # 11225501



HQ Series Rear Shockwaves

64-72 A-Body w/ Moser/GearFX Rear Ends



www.ridetech.com
812.482.2932





**Please Read And Understand All Instructions
And Warnings Prior To The Installation Of
This Product.**



THANK YOU

Congratulations on your new ridetech product! It's an honor that you've selected the ridetech brand to upgrade your ride. Our products are developed around quality and performance without compromise. We're confident you'll have many years (and miles) of pure driving enjoyment.
Thank you for choosing ridetech!

Road Map

Exploded Views & Parts Listing	3-4
Axle Bracket Installation	5
Shockwave Installation	6
Shock Tuning	7-8
Shockwave Care Guide	9

Shockwave Dimensions

Measured From Center-To-Center Of Shock Bearings

Compressed	11.85"
Ride Height @ 60%	14.50"
Extended	16.43"

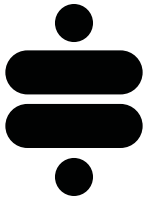

EXPLODED VIEWS AND PARTS LISTING

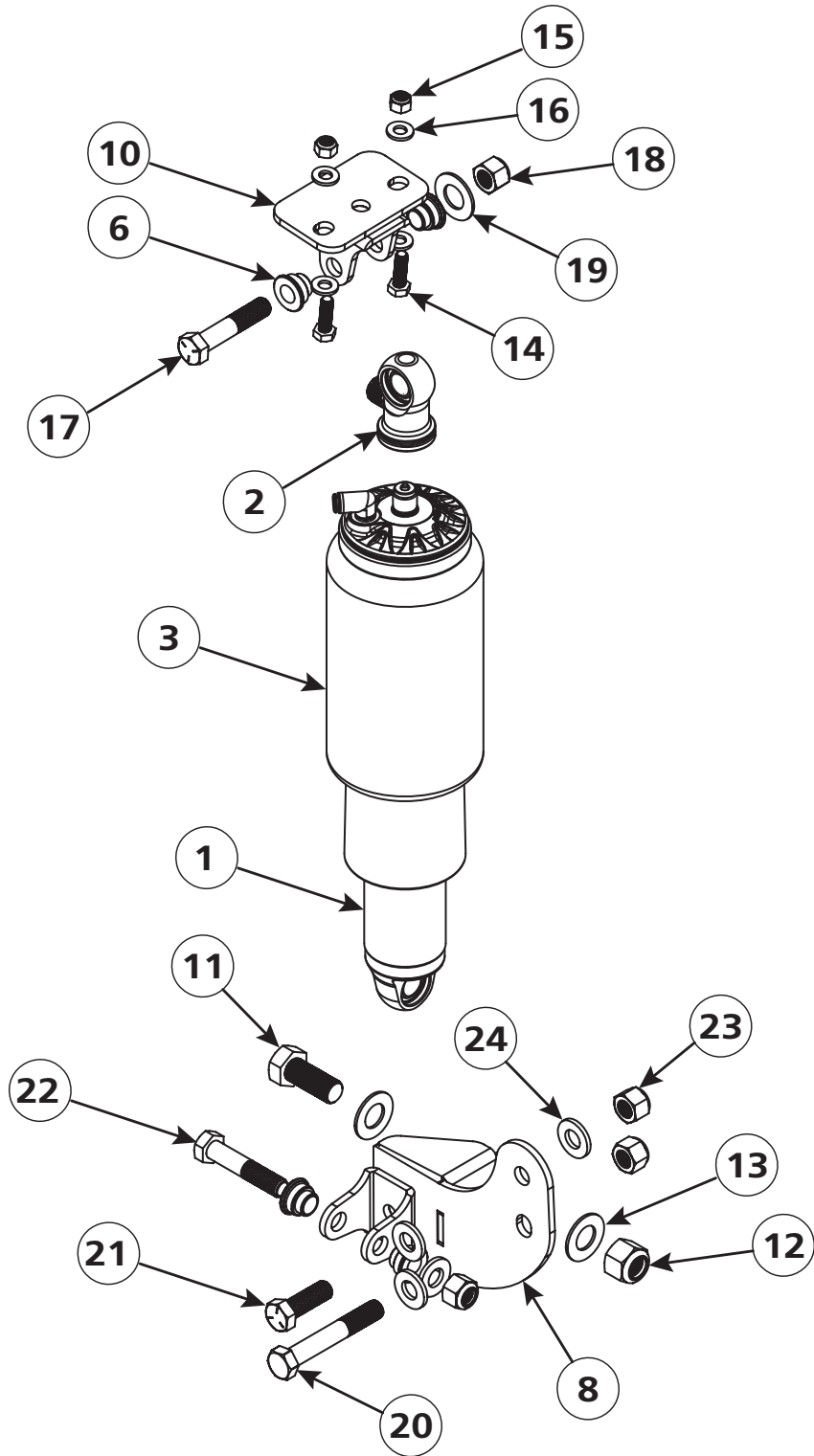
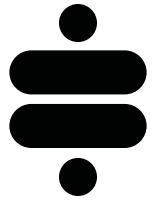

EXPLODED VIEWS AND PARTS LISTING

Item #	Part #	Description	QTY
1	982-10-805	5.2" Stroke HQ Series Shock	2
2	815-05-022-KIT	1.7" Shock Eyelet	2
3	24090799	7000 Series ShockWave	2
4	90001994	5/8" ID Bearing (installed in shock and eyelet)	4
5	90001995	Bearing Snap Ring (installed in shock and eyelet)	8
6	90002043	.500" ID spacer	8
8	90002307	Lower Shock Bracket - Driver	1
9	90002308	Lower Shock Bracket - Passenger	1
10	90002327	Upper Shock Mount	2
11	99621014	5/8-18 X 1 1/2 SAE HCS GR8	2
12	99622001	5/8-18 NYLON INSERT L/N GR8	2
13	99623001	5/8 SAE FLAT WASHER GR8	4

Hardware Kit: 99010110			
Item #	Part #	Description	Qty
Upper Mounting			
14	99311011	5/16"-18 X 1 1/4" BOLT GR8	4
15	99312002	5/16"-18 NYLOK NUT GR8	4
16	99313001	5/16" SAE FLAT WASHER GR8	8
17	99501050	1/2"-13 X 2 1/2" BOLT GR8	2
18	99502009	1/2"-13 NYLOK NUT GR8	2
19	99503014	1/2" SAE FLAT WASHER	2
Lower Mounting			
20	99501065	1/2"-13 X 3 3/4" BOLT GR8	2
21	99501053	1/2"-13 X 1 1/2" BOLT GR8	6
22	99501050	1/2"-13 X 2 1/2" BOLT GR8	2
23	99502009	1/2"-13 NYLOK NUT GR8	10
24	99503014	1/2" SAE FLAT WASHER	16

Axle Bracket Installation

1. Raise the vehicle to a safe and comfortable working height.

2. Remove the existing rear shocks and springs. Refer to the factory service manual for proper disassembly and removal instructions.

3. Remove the lower trailing arm bolt on one side of the car and allow the trailing arm to drop out of the OEM bracket. Only do one side at a time to prevent the axle from rotating.

4. Install the longer $\frac{1}{2}$ " x $3\frac{3}{4}$ " bolt through the lower trailing arm from the outside in. Install the lower bracket over the bolt and secure with a $\frac{1}{2}$ " Nylok nut and flat washer (Figure 1).

5. The bolt hole in the back of the bracket will align with the factory shock stud hole. Use a $\frac{5}{8}$ " x $1\frac{1}{2}$ " bolt, Nylok nut and flat washers (Figure 2).

6. Drill the upper bracket hole with a $\frac{1}{2}$ " bit. The edge of the bracket should be parallel to the axle bracket (Figure 3).

We recommend using a centering punch and $\frac{1}{8}$ " bit to drill a pilot hole.

Insert a $\frac{1}{2}$ " x $1\frac{1}{2}$ " bolt and secure with a $\frac{1}{2}$ " Nylok nut and flat washers.

Torque the $\frac{1}{2}$ " hardware to **75 ft-lbs.**
Torque the $\frac{5}{8}$ " hardware to **162 ft-lbs.**

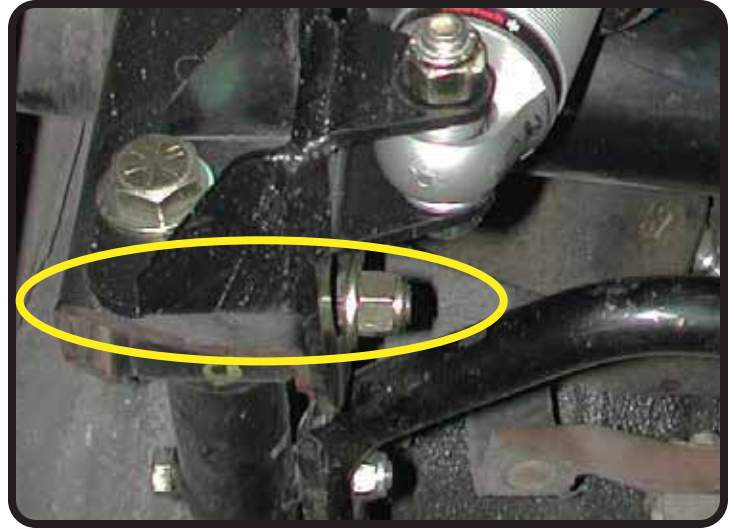

Figure 1



Figure 2

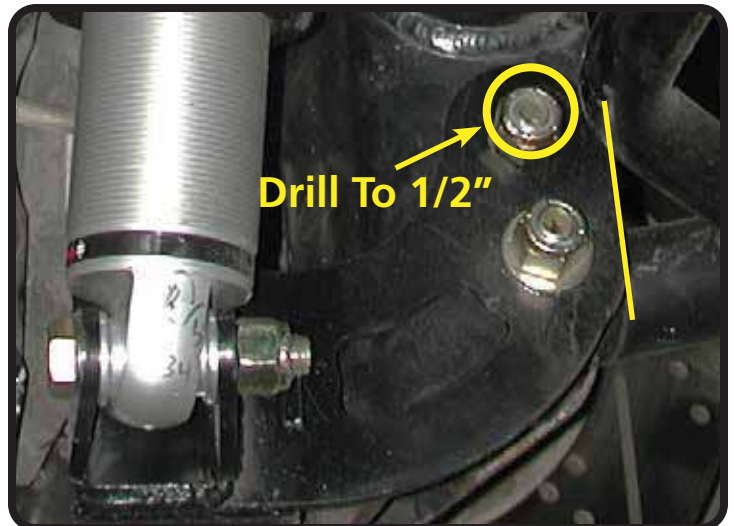

Figure 3

Shockwave Installation

7. Position the new upper shock mount bracket in the factory shock location. Install a 5/16" x 1.25" bolt with a 5/16" flat washer on each side, and secure with the 5/16" nylok nuts (Figure 4). Torque to **17 ft-lbs.**

NOTE: The bracket position should be offset to the centerline of the car.

8. Install a 90002043 shock spacer into each side of the Shockwave eyelet bearing. The small end of the spacer will snap into the bearing (Figure 5).

9. Position the eyelet into the upper shock mount. Insert a 1/2" x 2.5" bolt through the mount/eyelet and secure with a 1/2" nylok nut (Figure 6).

Torque to **75 ft-lbs.**

10. Install a 90002043 shock spacer into each side of the lower Shockwave bearing.

11. Position the shock into the lower shock mount. Insert a 1/2" x 2.5" bolt through the mount/eyelet and secure with a 1/2" nylok nut (Figure 7). Torque to **75 ft-lbs.**

12. Repeat on the opposite side.

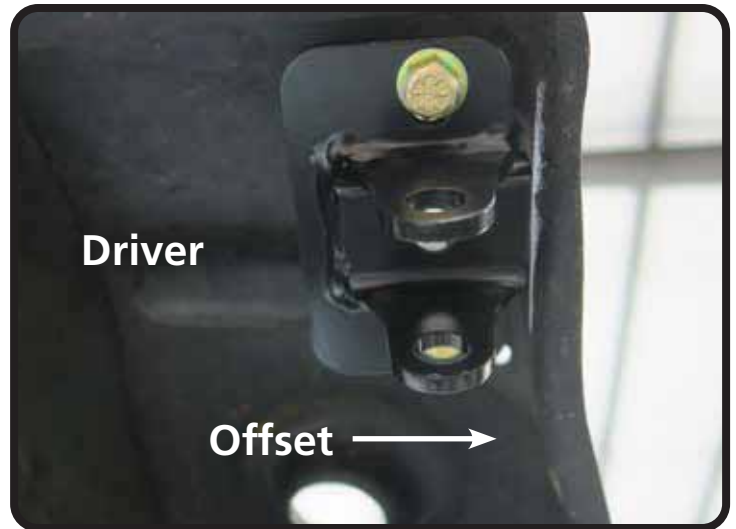
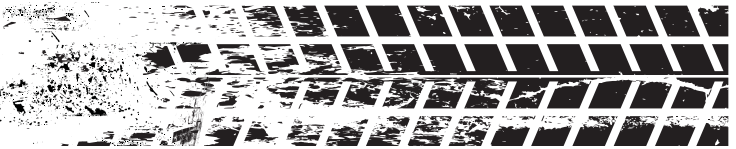

Figure 4



Figure 5



Figure 7



Figure 6



TUNING GUIDE

SINGLE-ADJUSTABLE SHOCKS



The Basics...

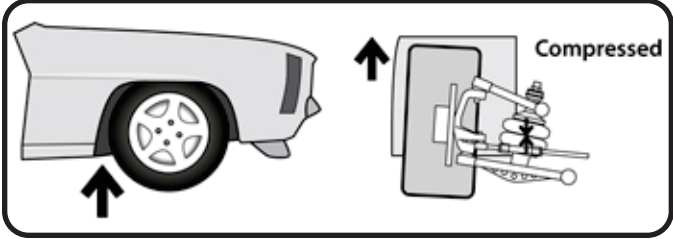

COMPRESSION

This typically occurs when you hit a bump in the road. The bump forces the wheel/tire/suspension assembly to "compress" or move upwards into the car.

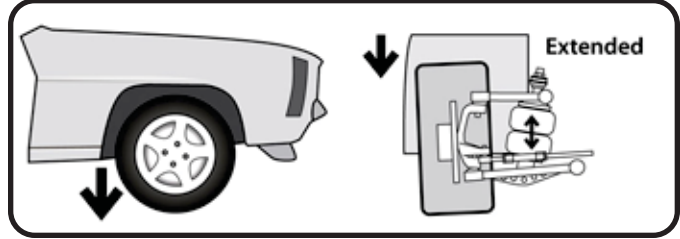

REBOUND

Rebound is the opposite of compression. This occurs when the wheel/tire/suspension assembly falls into a pothole, or simply "rebounds" from being compressed.

Where Are The Knobs?

HQ Series Shocks

- The adjustment knob is located on the top of the shock, either protruding from the side of the eyelet, or atop the stud.
- This knob provides rebound adjustment only.

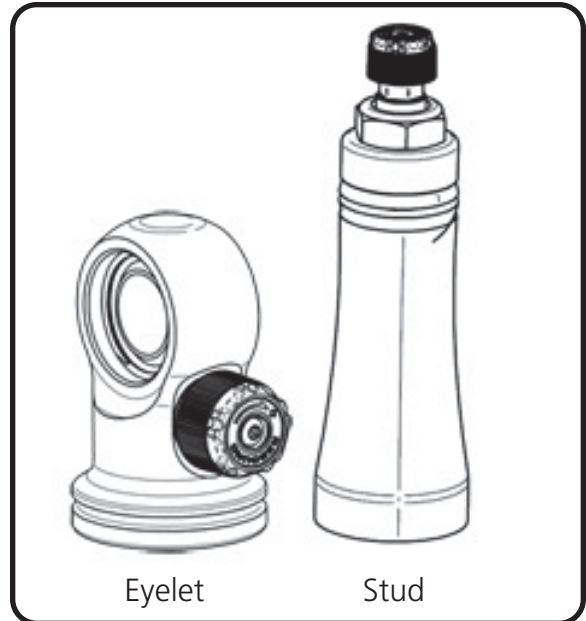

Knob Function

Counterclockwise

=
Softer



Clockwise

=
Firmer





TUNING GUIDE

SINGLE-ADJUSTABLE SHOCKS



Initial Rebound Setting

NOTE: Before jumping straight to a middle-of-the-road shock setting, we recommend you experience the full range of adjustment potential of your new shocks by first driving your vehicle at both the “full stiff” and “full soft” settings. Understanding how your shocks behave at these extremes will provide recognizable reference points as you attempt to dial in your settings.

1. Begin by setting your shocks to the “full stiff”, or minimal rebound position. You do this by turning the adjustment knob clockwise until it stops.

2. Now turn the adjustment knob counterclockwise 12 clicks. This is the approximate center of the adjustment range.

3. Take the vehicle for a test drive. Try to determine if you are experiencing any of the unwanted behaviors found at the extremes of the adjustment range. If you are satisfied with the ride quality and handling, you’re all set. Enjoy the ride!

4. If the vehicle feels too “floaty” or soft, turn the knob a few clicks clockwise to increase the damping effect.

If the ride quality is still too harsh or stiff, turn the knob a few more clicks counterclockwise to decrease the damping effect.

5. Take the vehicle for another test drive. If necessary, repeat the steps above until your desired optimal ride quality has been achieved.



General Guidelines

- The rear shocks typically have the most influence on ride quality. This is due to your seating position being closer to the rear than the front.
- Adjustments to the front shocks will generally require 3-4 clicks in any direction to be noticeable, while adjustments to the rear shocks may only require 1-2 clicks to be felt.
- Don’t be afraid to turn the knobs and experience the full adjustment range. You are not going to hurt anything and you can always go back if you adjust too far one way or the other.



SHOCKWAVE CARE GUIDE



PLEASE READ



The air spring locking ring **IS NOT** adjustable. This ring is set to a specific position at the factory to optimize the air spring stroke with the shock stroke. Attempting to adjust this ring will void your warranty.



DO NOT attempt to remove the press-in air fitting. It may result in damage to the composite cap and void your warranty.



DO NOT drive the vehicle with the air springs fully deflated. Severe damage to the internal bump stop, shock bushings, and shock mounts may occur.

- Avoid driving the vehicle with the air springs overinflated or “topped out”. Over time the shock valving may suffer severe damage or total failure. Our recommended ride-height range is between 40-60% of total suspension travel.
- Do not allow the air spring bellows to rub on or interfere with any surrounding objects. Ensure the ShockWaves are adequately distanced from the exhaust system. Damage or total failure may occur.
- Do not use harsh or abrasive chemicals or solvents to clean your ShockWaves. A mild soap and water solution is sufficient.
- When working around or near your shocks, avoid allowing over spray of harsh chemicals or solvents to make contact with your ShockWaves.
- When attempting to clock the air fitting, you may rotate the air spring assembly on the shock. Ensure the fitting does not contact the vehicle frame or other surrounding objects.