



**INSTALLATION
INSTRUCTIONS**



Part # 11239122



**Rear Sway Bar - Adjustable Rate
1964-1967 GM A-Body**



www.ridetech.com
812.482.2932





**Please Read And Understand All Instructions
And Warnings Prior To The Installation Of
This Product.**

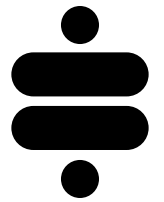

THANK YOU

Congratulations on your new Ridetech product! It's an honor that you've selected the Ridetech brand to upgrade your ride. Our products are developed around quality and performance without compromise. We're confident you'll have many years (and miles) of pure driving enjoyment.
Thank you for choosing Ridetech!

Road Map

Parts Listing	3
Exploded View	4
Sway Bar Installation	5-6
Frame Tab & Locking Ring Installation	7
Rate Adjustments	7

**NOTE: The bushings in this kit contain an anti-friction lining.
No lubrication is required.**

TORQUE SPECIFICATIONS	
3/8"-16	30 ft-lbs
7/16"-20	55 ft-lbs
M10-1.5	37 ft-lbs

PARTS LISTING

COMPONENTS			
Item #	Part #	Description	Qty
1	90001229	Rear Sway Bar	1
2	90001249	Axle Bracket, 3" Axle Tube	2
3	90001345	Bushing Strap	2
4	70015012	Lined Sway Bar Bushing	2
5	90001270	Frame Tab, Driver	1
6	90001269	Frame Tab, Passenger	1
7	70014301	Clamp Ring	2
8	70014207	Clamp On Sway Bar End	2
9	90002571	10mm 90 Degree End Links	4
10	90001253	Sway Bar End Link Spacer, 4"	2
11	90000088	7/16" U-bolt	2
12	99112002	M10-1.5 Nylok Nuts - End links	4
HARDWARE KIT: 99010084			
Tab To Frame			
13	99371005	3/8" -16 x 1 1/4" Hex Bolt	4
14	99373002	3/8" Flat Washer	4
15	99372001	3/8" -16 Nylok Nut	4
Sway Bar To Axle			
16	99433002	7/16" SAE Flat Washer	4
17	99432002	7/16" -20 Nylok Nut	4
Sway Bar End Clamp			
18	99371054	3/8" -16 x 7/8" Socket Head Bolt	4
-	90002276	Antisize	1

! This sway bar may not be compatible with fabricated rear end housings that exceed 24" in width. !



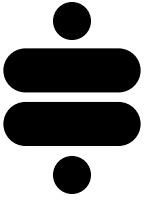

EXPLODED VIEW

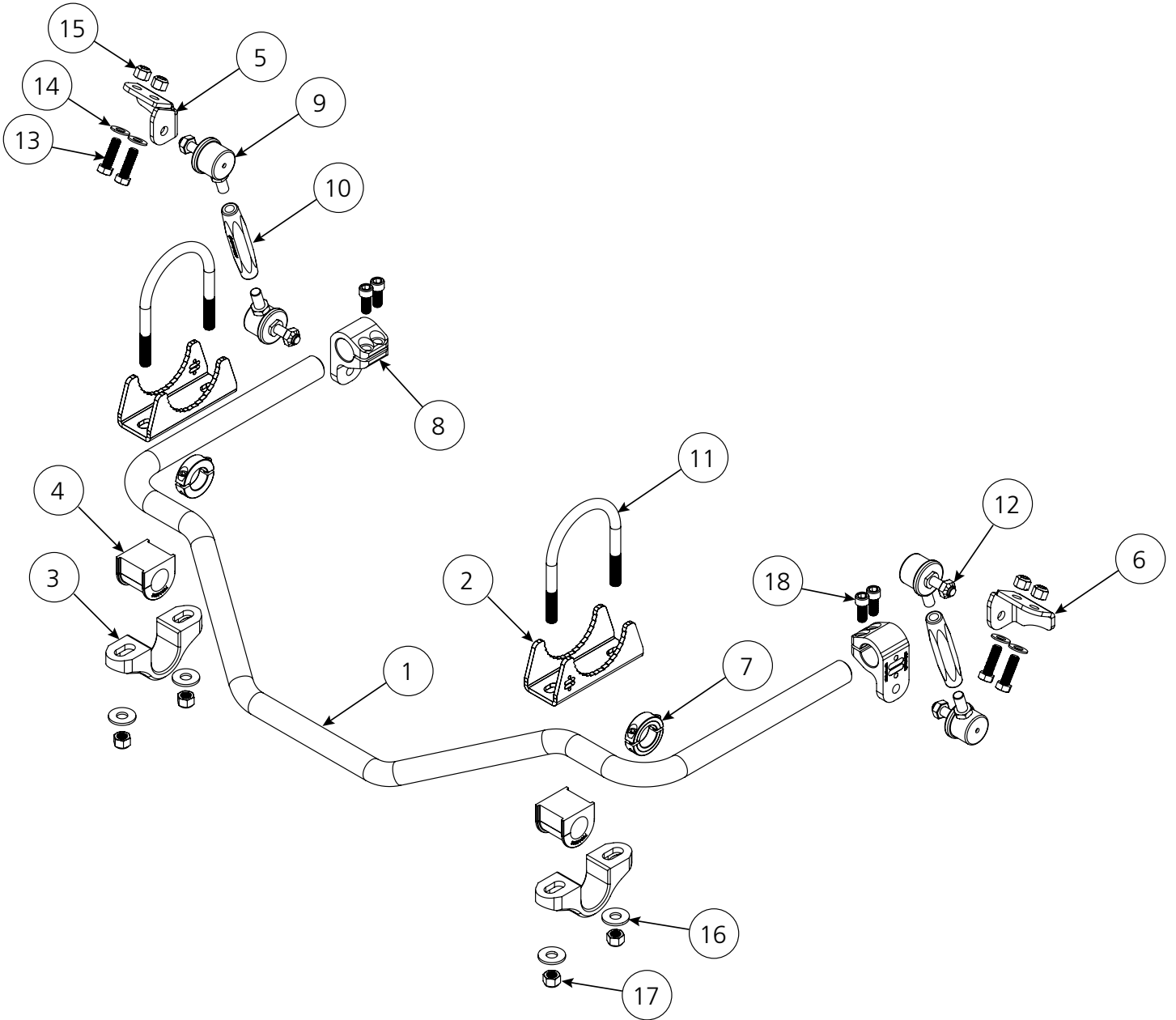
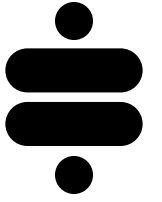

Sway Bar Installation

1. Raise the vehicle to a safe and comfortable working height.
2. Remove the existing sway bar (if applicable).
3. Spread open each bushing and install onto the bar. Then slide a billet strap over each bushing (Figure 1).

Position the bushings at the locations circled in Figure 2.

4. Install the u-bolts onto the axle tube with the threads pointing down (Figure 3). You may need to raise the brake lines in the area of the u-bolts. The u-bolts will be approximately 23 1/2" apart and an equal distance from the brake backing plates on each side.

5. Install an axle bracket onto each u-bolt with the flat side facing down (Figure 4). The "teeth" of the mount should touch the axle tube.



Figure 1

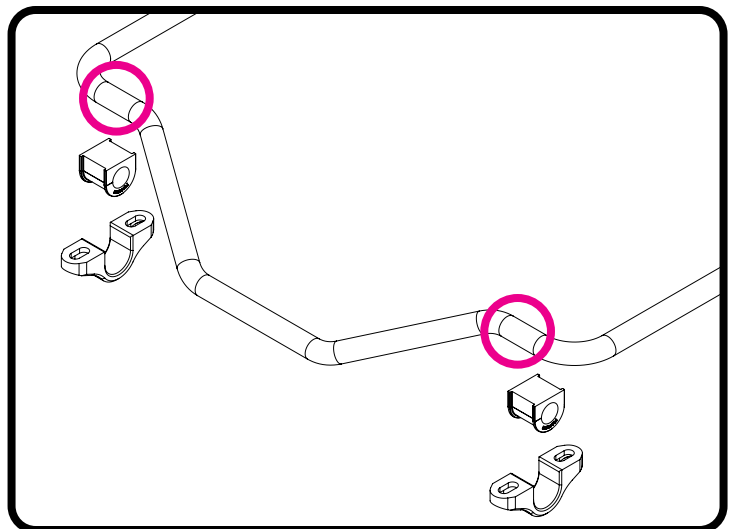

Figure 2



Figure 4



Figure 3

Sway Bar Installation

6. Position the bar in the car with the center bend toward the ground. Install a $7/16''$ flat washer & $7/16''$ -20 nylok nut on the threads of the u-bolts (Figure 5). Snug the hardware and verify the bar is centered and the axle mounts are level.

Torque the u-bolt nuts to **55 ft-lbs.**

7. Apply anti-sieze to (4) $3/8''$ -16 x $7/8''$ socket head cap screws and thread them into the clamp-on ends. Install a clamp-on end on each ends of the bar. The end link mounting hole should be mounted to the outside of the bar and pointing down. Start with the mount flush with the end of the bar (Figure 6).

8. Attach the sway bar linkage to the clamp-on mount using the hardware on the linkage. Attach a frame tab to the top of the linkage with the open side of the frame tab facing to the rear of the car. See Figure 7. Attach the linkages and tab to both sides.

Torque the M10 nuts to **37 ft-lbs.**

NOTE: The frame tabs are side specific.



Figure 5



Figure 6

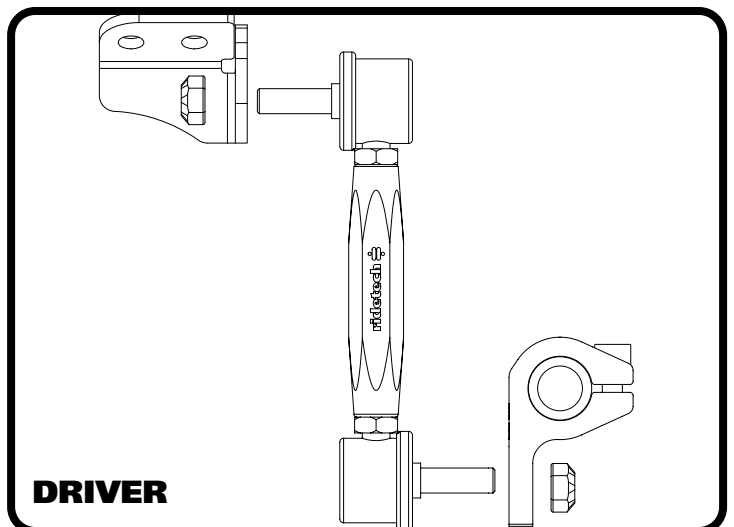
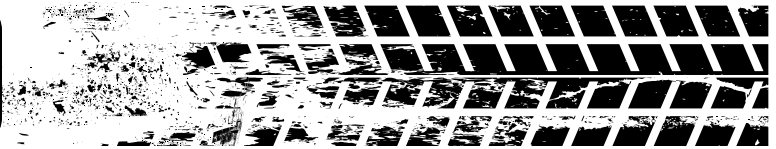

Figure 7

Frame Tabs & Locking Rings



9. Swing the tab up to the frame, keeping the linkage straight from side to side. Use the tab to mark the location of the holes that will need to be drilled in the frame. Drill the holes with a 3/8" drill bit. Install a 3/8" flat washer on each of (2) 3/8"-16 x 1 1/4" hex bolts and install them through the bracket and drilled holes. Install a 3/8"-16 nylok nut on each of the bolts sticking through the frame. Torque the frame tab bolts to **30 ft-lbs** and repeat on the opposite side.

10. Install the locking rings on the outboard side of each bushing assembly (Figure 9). Use a hex key to take the locking ring apart. Reassemble it on the bar positioned next to the outside of the bushing assembly. Push the locking ring up against the bushing assembly and tighten.



Figure 8



Figure 9

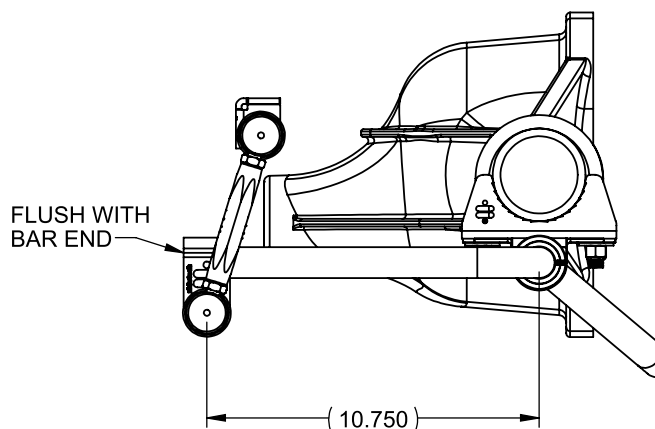

MINIMUM RATE 200 LB/INCH

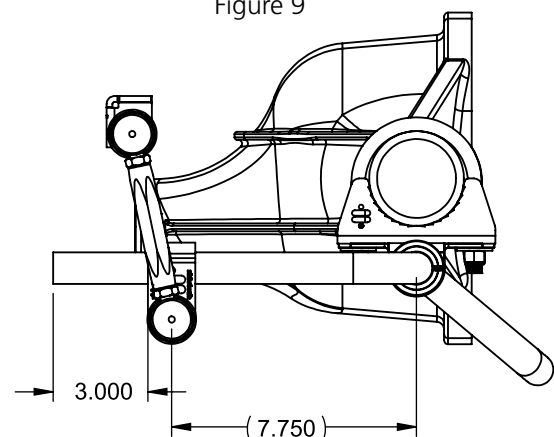

HIGH RATE 400 LB/INCH

11. The rate of this sway bar is adjustable by changing the position of the clamp-on ends on the bar. The standard setting is with the clamp-on mounts even with the end of the bar. The stiffest setting is with the clamp-on end positioned 3" from the end of the sway bar. See the illustrations above. The position of the mounts will be determined by several factors; spring rate, front bar size, and even tire size. We recommend running this rear sway bar with Ridetech's front sway bar (11239120) for the best performance.