



INSTALLATION INSTRUCTIONS



Part # 11243001



Front HQ Series ShockWaves

1968-1972 GM A-Body



www.ridetech.com
812.482.2932





**Please Read And Understand All Instructions
And Warnings Prior To The Installation Of
This Product.**



THANK YOU

Congratulations on your new Ridetech product! It's an honor that you've selected the Ridetech brand to upgrade your ride. Our products are developed around quality and performance without compromise. We're confident you'll have many years (and miles) of pure driving enjoyment.
Thank you for choosing Ridetech!

Road Map

Exploded View & Parts Listing	3
Installation Preparation	4
ShockWave Installation	5
ShockWave Care Guide	6
Shock Tuning Guide	7-8

ShockWave Dimensions

Measured From Center-To-Center Of Shock Mounts

Compressed	11.05"
Ride Height	12.85"
Extended	14.05"



EXPLODED VIEWS AND PARTS LISTING

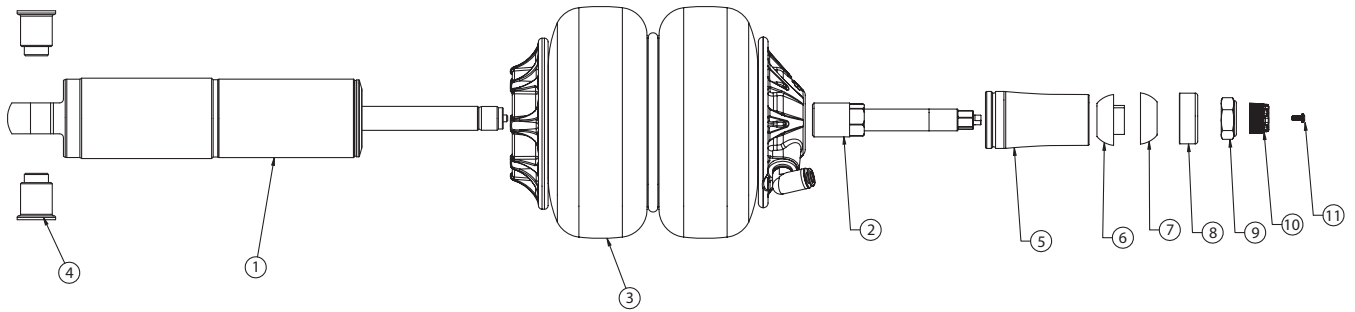
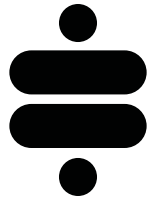

**THE DELRIN BALL REQUIRES A 3/4" HOLE FOR THE FLANGE TO PASS THROUGH.
THIS MAY BE DRILLED WITH A UNIBIT.**

Item #	Part #	Description	QTY
1	982-10-803	3.6" Stroke HQ Series Shock	2
2	90009989	2.75" Stud Top (Installed on Shock) - Includes Adjuster Knob & Screw	2
3	24090199	1000 Series 6.5" Double Convoluted AirSpring	2
4	90002062	Spacers - INCLUDED WITH STRONG ARMS	4
5	90002313	2.75" Aluminum Stud Top Base	2
6	90001904	Bottom Delrin Ball	2
7	90001903	Top Delrin Ball	2
8	90001902	Delrin Ball Aluminum Top Cap	2
9	99562003	9/16"-18 Thin Nylok Nut	2
10	210-35-120-0	Adjuster Knob - (90009989 assembly)	2
11	90009969	#4-40 X 1/4" SS, 18-8 Pan Head Torx Cap - (90009988 assembly)	2
	70012161	2.75" Stud Top Metering Rod (installed in stud top)	2
	90001994	5/8" ID Bearing (installed in shock and eyelet)	4
	90001995	Bearing Snap Ring (installed in shock and eyelet)	8

Installation Prep

1. Raise the vehicle to a safe and comfortable working height and remove the existing front shocks and coil springs. Refer to the factory service manual for the correct disassembly procedure.

2. Drill the OEM shock hole out to 3/4". This can be done with a Unibit. To prevent contact with the top of the Shockwave, the coil spring retaining fingers must be cut off (Figure 1). A die grinder works well here.

3. Some trimming must also be done on the outside of the frame pocket to allow clearance for the Shockwave (Figure 2).

4. To allow clearance for the Shockwave, some trimming must be done on the outside edge of the coil spring pocket as shown by the white line in the picture. This is best done with either a cut-off wheel or plasma cutter. Grind all cuts smooth when finished.

NOTE: It may be helpful to go ahead and install the lower StrongArms and Shockwaves to determine exactly how much needs to be trimmed.

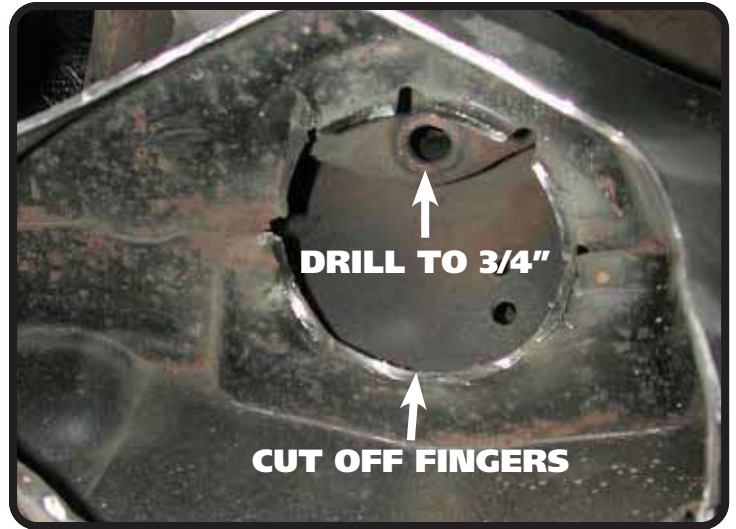

Figure 1

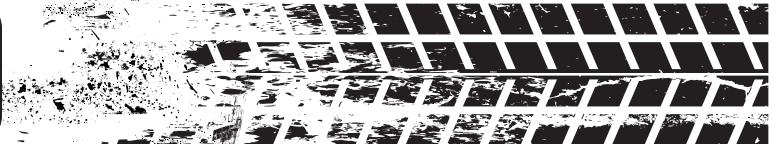

Figure 2



Figure 3

ShockWave Installation



NOTE: This is a good time to route air line. It may be ran through the sub-frame toward the rear of the vehicle.

5. Place the ShockWave into the coil spring pocket with the stud sticking through the OEM shock hole. See Figure 4. The OEM shock hole must be drilled out to $\frac{3}{4}$ ".

6. Tighten the 9/16" nut snugly against the top cap (#4). Do not over tighten. You should still be able to articulate the shock by hand.

NOTE: The air fitting location can be rotated by holding the shock and twisting the bellow assembly.

7. Insert an aluminum shock spacer into each side of the shock bearing, raise the lower arm up to the ShockWave and attach the shock to the arm using the $\frac{1}{2}$ " x $3\frac{1}{4}$ " bolt and Nylok nut supplied with the lower arms (Figure 5). Torque to **75 ftbs**.

8. Raise the lower control arm to full compression and check to make sure the ShockWave does not rub on anything through its range of motion.

NOTE: Optimal ride quality is usually achieved around 40-60% of suspension travel. Depending on vehicle weight, this typically occurs around 100 psi.

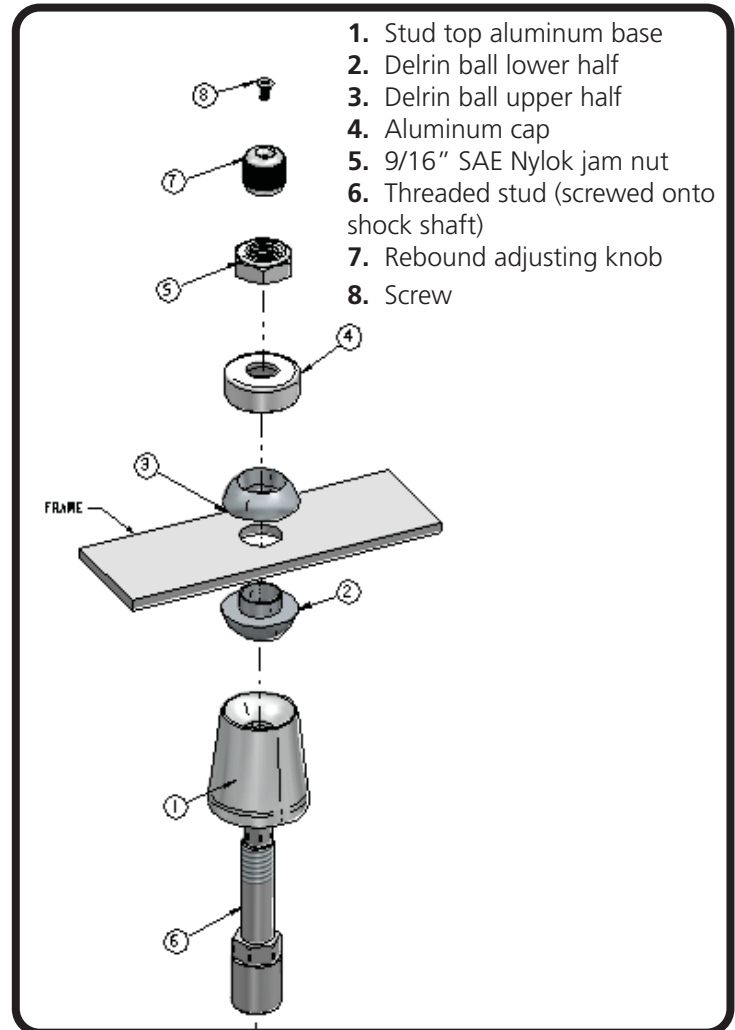

Figure 4

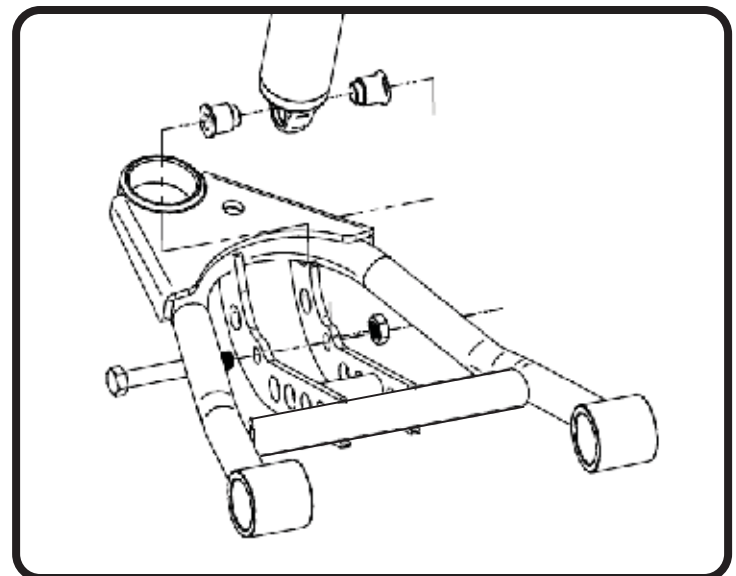

Figure 5



SHOCKWAVE CARE GUIDE



PLEASE READ



The air spring locking ring **IS NOT** adjustable. This ring is set to a specific position at the factory to optimize the air spring stroke with the shock stroke. Attempting to adjust this ring will void your warranty.



DO NOT attempt to remove the press-in air fitting. It may result in damage to the composite cap and void your warranty.



DO NOT drive the vehicle with the air springs fully deflated. Severe damage to the internal bump stop, shock bushings, and shock mounts may occur.

- Avoid driving the vehicle with the air springs overinflated or “topped out”. Over time the shock valving may suffer severe damage or total failure. Our recommended ride-height range is between 40-60% of total suspension travel.
- Do not allow the air spring bellows to rub on or interfere with any surrounding objects. Ensure the ShockWaves are adequately distanced from the exhaust system. Damage or total failure may occur.
- Do not use harsh or abrasive chemicals or solvents to clean your ShockWaves. A mild soap and water solution is sufficient.
- When working around or near your shocks, avoid allowing over spray of harsh chemicals or solvents to make contact with your ShockWaves.
- When attempting to clock the air fitting, you may rotate the air spring assembly on the shock. Ensure the fitting does not contact the vehicle frame or other surrounding objects.



TUNING GUIDE

SINGLE-ADJUSTABLE SHOCKS



The Basics...

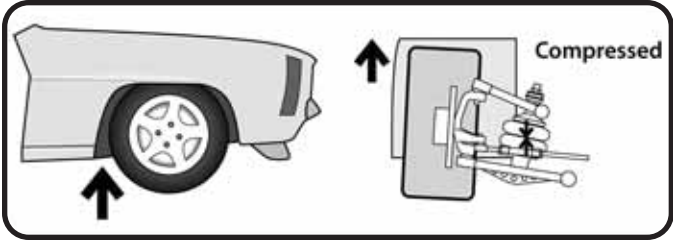

COMPRESSION

This typically occurs when you hit a bump in the road. The bump forces the wheel/tire/suspension assembly to "compress" or move upwards into the car.

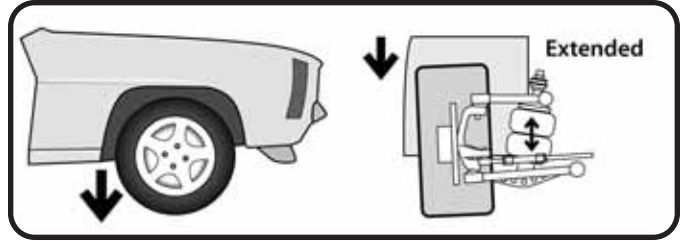

REBOUND

Rebound is the opposite of compression. This occurs when the wheel/tire/suspension assembly falls into a pothole, or simply "rebounds" from being compressed.

Where Are The Knobs?

HQ Series Shocks

- The adjustment knob is located on the top of the shock, either protruding from the side of the eyelet, or atop the stud.
- This knob provides rebound adjustment only.

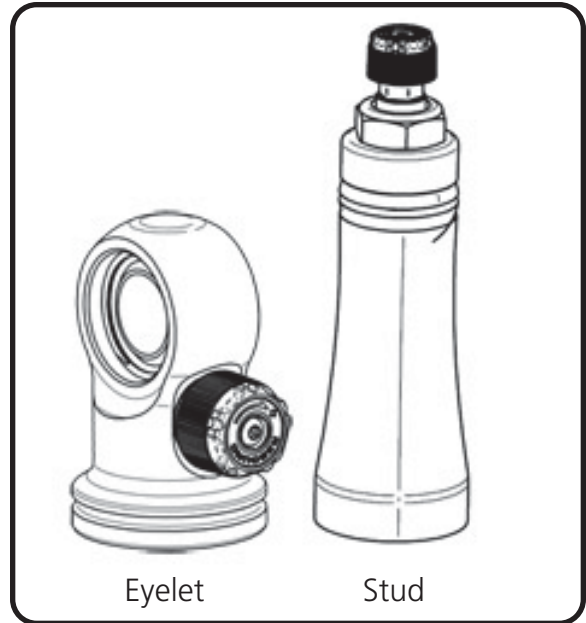

Knob Function

Counterclockwise

=
Softer

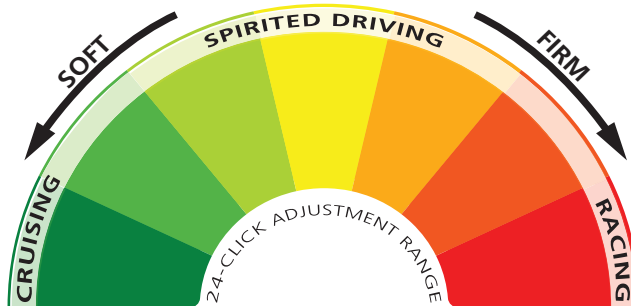

Clockwise

=
Firmer





TUNING GUIDE

SINGLE-ADJUSTABLE SHOCKS



Initial Rebound Setting

NOTE: Before jumping straight to a middle-of-the-road shock setting, we recommend you experience the full range of adjustment potential of your new shocks by first driving your vehicle at both the “full stiff” and “full soft” settings. Understanding how your shocks behave at these extremes will provide recognizable reference points as you attempt to dial in your settings.

1. Begin by setting your shocks to the “full stiff”, or minimal rebound position. You do this by turning the adjustment knob clockwise until it stops.

2. Now turn the adjustment knob counterclockwise 12 clicks. This is the approximate center of the adjustment range.

3. Take the vehicle for a test drive. Try to determine if you are experiencing any of the unwanted behaviors found at the extremes of the adjustment range. If you are satisfied with the ride quality and handling, you’re all set. Enjoy the ride!

4. If the vehicle feels too “floaty” or soft, turn the knob a few clicks clockwise to increase the damping effect.

If the ride quality is still too harsh or stiff, turn the knob a few more clicks counterclockwise to decrease the damping effect.

5. Take the vehicle for another test drive. If necessary, repeat the steps above until your desired optimal ride quality has been achieved.



General Guidelines

- The rear shocks typically have the most influence on ride quality. This is due to your seating position being closer to the rear than the front.
- Adjustments to the front shocks will generally require 3-4 clicks in any direction to be noticeable, while adjustments to the rear shocks may only require 1-2 clicks to be felt.
- Don’t be afraid to turn the knobs and experience the full adjustment range. You are not going to hurt anything and you can always go back if you adjust too far one way or the other.