

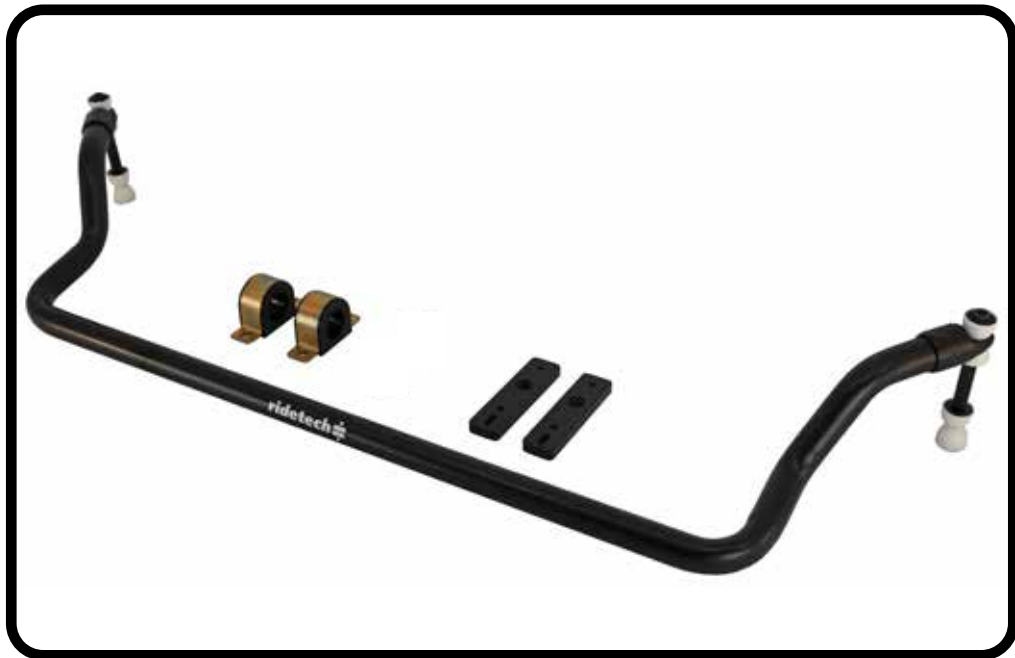

### Part # 11249120 - 1968-1972 GM A-Body Front SwayBar

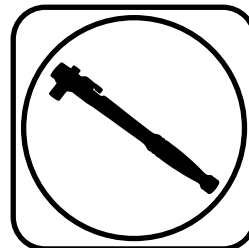

#### Recommended Tools



## 1968-1972 GM A-Body Front SwayBar Installation Instructions

#### Table of contents

- Page 2..... Included Components and Hardware List
- Page 3..... SwayBar Installation

#### Hardware Torque Specifications

- 5/16"-16..... 17 ftlbs
- 3/8"-16..... 30 ftlbs



# Major Components .....In the box

Part #	Description	QTY
90001226	Front Sway Bar	1
90002933	End Link Kit	1
90002513	Bushing Strap	2
70015015	Lined Sway Bar Bushing	2
90001254	Bushing Mount Adapter	2

## HARDWARE KIT .....99010083

QTY	Part Number	Description
<b>ADAPTER PLATE</b>		
2	99371032	3/8"-16 x 1 1/4" Flat Head
2	99311025	5/16"-18 x 1 1/4" Flat Head
2	99371005	3/8"-16 x 1 1/4" Hex Bolt
2	99311011	5/16"-18 x 1 1/4" Hex Bolt
2	99373002	3/8" Flat Washer
2	99313001	5/16" SAE Flat Washer
2	99373006	3/8" Split Lock Washer
2	99313003	5/16" Split Lock Washer
1	90002263	Red Loctite

QTY	Part Number	Description
<b>BUSHING STRAP</b>		
4	99371065	3/8"-16 x 3/4" Hex Bolt
4	99373002	3/8" Flat Washer
4	99373006	3/8" Split Lock Washer

## Getting Started.....

**Note:** This sway bar kit utilizes a anti-friction lining in the sway bar bushing. The lining allows the sway bar to move freely and quietly in the bushing. No lubrication is required.

**Note:** The threaded holes in the frame can be either 5/16"-18 or 3/8"-16. Hardware is supplied for both.

1. Jack the vehicle up to a safe working height and support with jack stands. Make sure the jack stands are stable before working under the car.
2. Remove the stock sway bar.
3. After removing the stock sway bar, determine what size hardware the frame will require.



**4.** Open the sway bar bushing at the split and slip it **OVER** the sway bar. Do this for both bushings.



**6.** Slip the Bushing Straps over the Sway Bar Bushings.



6. This kit contains an adapter plate to attach the sway bar to the frame. Depending on the year of the car, the hardware size can vary. Before continuing to the next step, you will need to determine the bolt size required for your installation. The threaded holes in the frame can be either 5/16"-18 or 3/8"-16. Hardware is supplied for both.



7. Hold the Frame Plate up to the OEM holes, the Counter Sunk hole will be positioned over the front hole with the slot to the rear. Apply Red Loctite to the Flat Head Bolt. The rear 1 1/4" long bolt uses a Split Washer and Flat Washer. Torque Hardware.



8. Slide the SwayBar into position on the car with the SwayBar arms above the tie rods. Install a 3/8" Lock Washer & 3/8" Flat Washer on the 3/8"x 3/4" Hex Bolts. Do **NOT** Complete tighten the Hardware, it will be left partially loose until the End Links are installed.

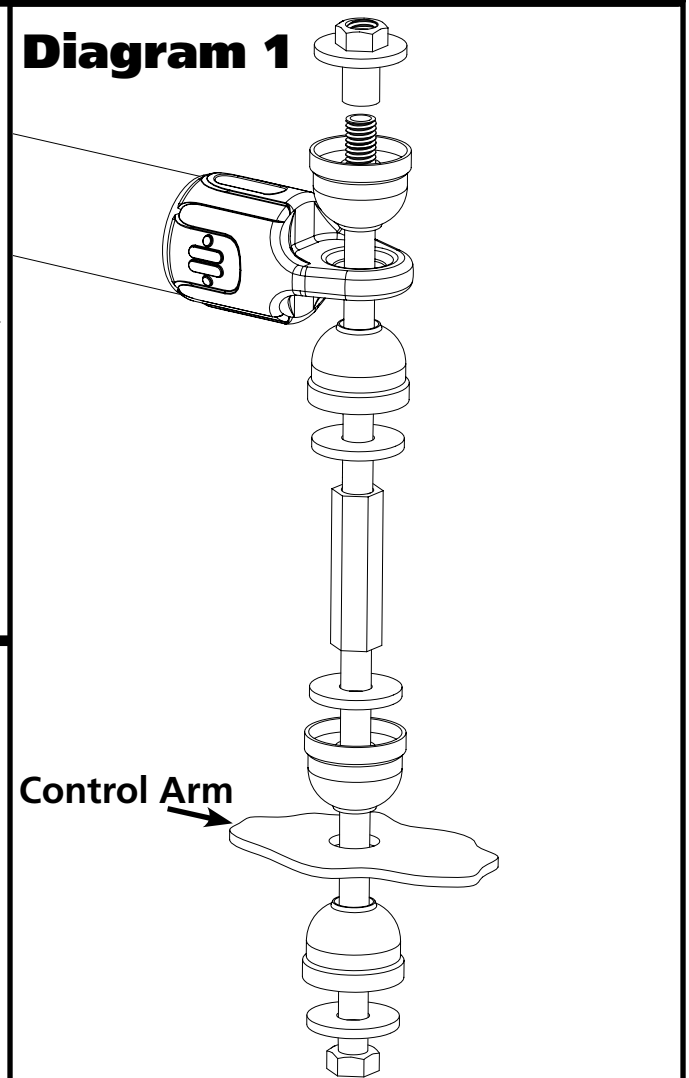

9. Install the End Links using **Diagram 1** as a reference. Install both end links before tightening the end link hardware. Tighten the end link barrel nut until it is flush with the end of the bolt, and then tighten it 2 more complete rounds.

10. Torque the SwayBar mounting hardware to 30 ftlbs.