



### Part # 11260201 - 1968-1974 GM "X" Body HQ Series CoilOver System

#### Recommended Tools

#### Front Components:

11263510	Front CoilOvers
11162899	Front Lower StrongArms
11163699	Front Upper StrongArms
11009310	Ridetech Tall Spindle
11169120	Front SwayBar

#### Rear Components:

11267199	Rear 4Link System
11266510	Rear Coilover Instructions

#### Miscellaneous Components:

85000000	Spanner Wrench
----------	----------------

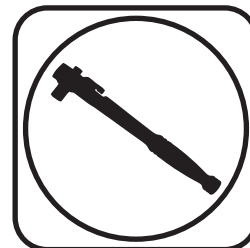

# 1968-1974 GM "X" Body Coilover Installation Instructions

#### Table of contents

Pages 2-5.....	Front CoilOvers
Pages 6-9.....	Front Lower StrongArms
Pages 10-15.....	Front Upper StrongArms
Pages 16-18.....	Tall Spindle
Pages 19-21.....	Front SwayBar
Pages 22-38.....	Rear 4-Link
Pages 39-40.....	Rear CoilOvers
Pages 41-44.....	CoilOver Assembly and Shock Adjustment

SOME 1973-1974 X-BODIES CAN HAVE A DIFFERENT REAR FRAME RAIL. SEE PAGE 27.





**Part # 11263510**

**1968-1974 GM X-Body (Nova) HQ Front CoilOvers**

Recommended Tools

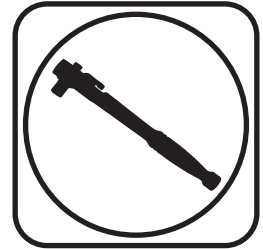

**1968-1974 GM "F"Body HQ Series Front CoilOvers**

# Installation Instructions

### Table of contents

- Page 3..... Included Components
- Page 4..... CoilOver Assembly
- Page 5..... CoilOver Installation

### ShockWave Dimensions:

Center of bearing to Stud Mounting Surface:

- Compressed: 10.48"
- Ride Height: 12.55"
- Extended: 14.08"





### Major Components .....In the box

Item #	Part #	Description	QTY
1	982-10-803	3.6" Stroke HQ Series Shock	2
2	59080700	CoilSpring 8" 700lb	2
3	70010828	Delrin Spring Washer	4
4	803-00-199(kit)	Lower Spring Adjuster Nut (803-00-199 kit)	2
5	803-00-199(kit)	Adjuster Nut Locking Screw (803-00-199 kit)	2
6	803-00-199(kit)	Upper CoilSpring Retaining Plate (803-00-199 kit)	2
7	803-00-199(kit)	CoilSpring Plate Retaining Ring (803-00-199 kit)	2
8	90009989(kit)	2.75" Stud Adjuster Assembly	2
9	90002313	2.75" Stud Top Base	2
10	90001904	Delrin Ball Lower Half	2
11	90001903	Delrin Ball Top Half	2
12	90001902	Delrin Ball Upper Cap	2
13	99562003	9/16-18" Nylok Nut	2
14	210-35-120-0	Shock Adjuster Knob	2
15	90009969	Adjuster Knob Retaining Screw	2
	90001994	5/8" ID Bearing (installed in shock body)	2
	90001995	Bearing Snap Ring (installed in shock body)	4

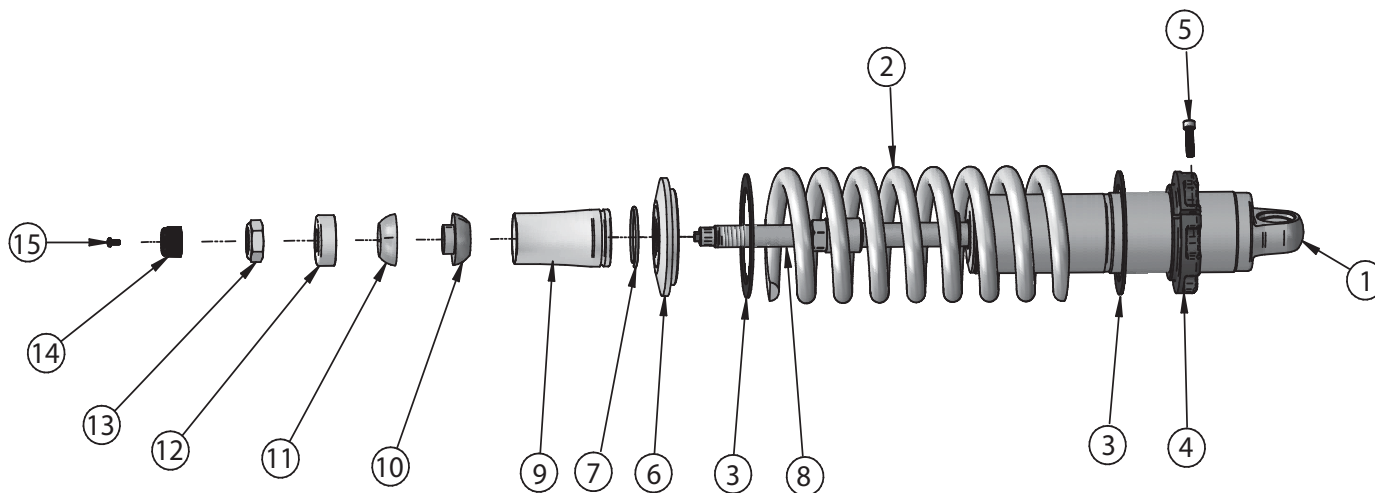

**BEARING SPACERS (90002062) ARE INCLUDED WITH THE FRONT LOWER CONTROL ARMS**



### CoilOver Assembly

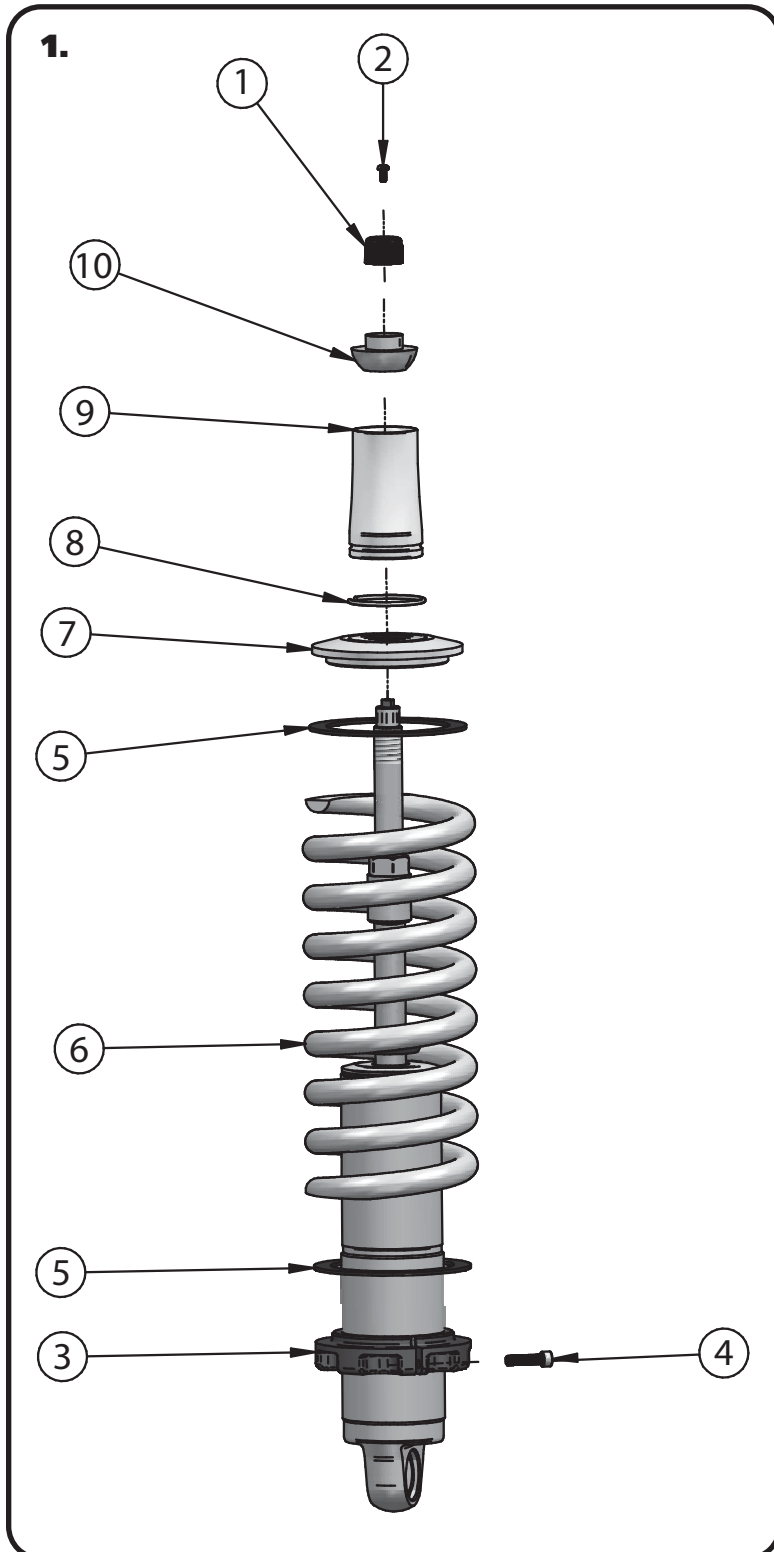

- 1.** To Assemble the CoilOver you need to:
  - a.** Remove Screw (2) from center of Adjustment Knob (1) and remove Adjustment Knob.
  - b.** Remove Nylok Nut, Delrin Upper Cap, Delrin Upper and Lower Balls, along with the base from the Coliover stud.
  - c.** Thread Adjuster Nut (3) onto the CoilOver body. Once it is threaded on the shock body, lightly thread in the locking screw (4) into the Adjuster Nut.
  - d.** Install a Delrin Spring Washer (5) onto the Adjuster Nut.
  - e.** Slide the CoilSpring (6) onto the CoilOver.
  - f.** Install another Delrin Spring Washer (5) on top of the CoilSpring.
  - g.** Install the Upper CoilSpring Plate (7) onto the CoilSpring.
  - h.** Install the CoilSpring Retaining Ring (8) onto the Stud Top Base (9). It fits into the groove in the base.
  - i.** Slide the Stud Top Base onto the shock until it bottoms out on the stud. It may be necessary to thread the Adjuster Nut down the shock body (to lower the spring) if the base will not slide all the way down onto the stud.
  - k.** Slide the Lower Delrin Ball (10) (it has the collar sticking up around the center hole) on to the Stud Top.

Repeat on second CoilOver.



### CoilOver Installation

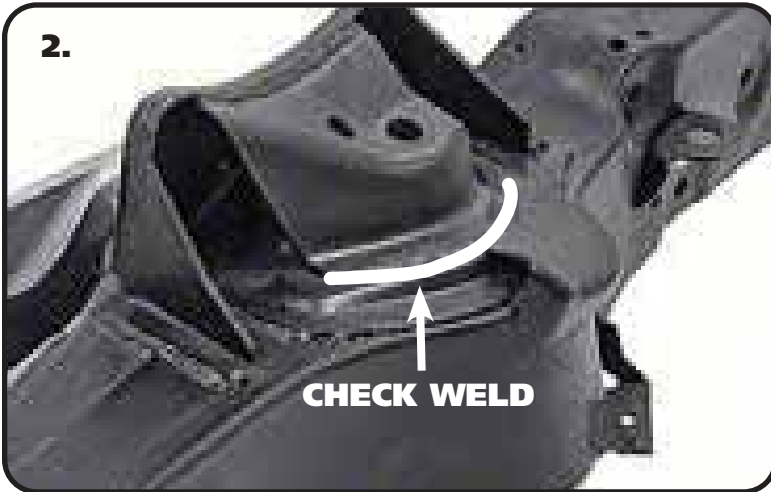

2. Check the weld in the area pointed out. We have seen some very poor factory welds in this area. If it doesn't look adequate to support the vehicle, reweld the area.

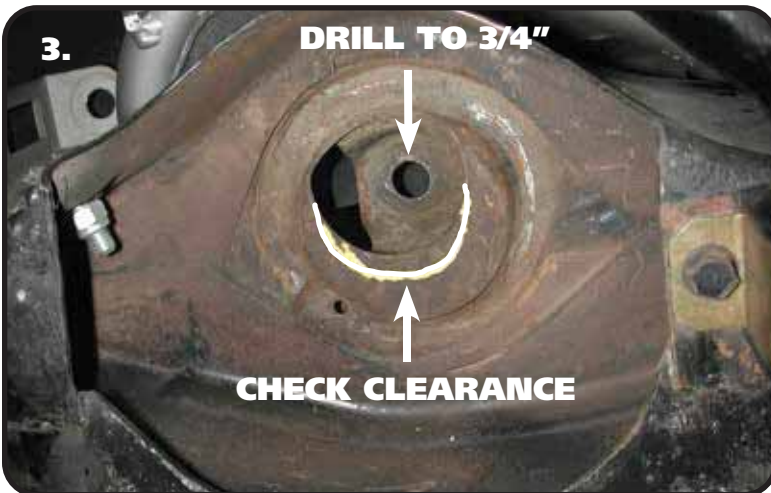

3. Drill the OEM shock hole out to 3/4". This can be done with a Unibit. The CoilOver stud top will come in contact with the coil spring retainer, so it must be opened up towards the engine. A die grinder works well here.

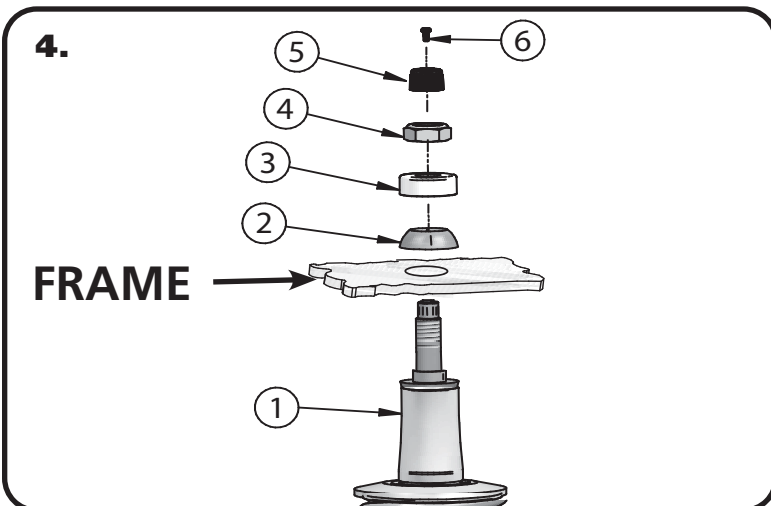

4. With the CoilOver(1) assembled, it is time to bolt them into the car. **The factory shock hole will need to be drilled out to 3/4", this can best be done using a Unibit.** Insert the CoilOver Stud Top through the factory hole in the frame. Install the Upper Delrin Ball(2) onto the shock stud with the flat side facing the frame. Next, install the Delrin Ball cap (3) onto the shock stud with the Concave side facing the Upper Delrin ball. Install the Nylok Nut(3) onto the shock stud and lightly tighten. There needs to be some resistance on the ball but not tight enough that it will not rotate freely. Reinstall the adjuster knob(5) using the screw (6) that was removed during step 1.

**TIGHTENING THE TOP 9/16"-18 NUT:** SNUG THE NUT DOWN AGAINST THE TOP CAP. YOU NEED TO BE ABLE TO ARTICULATE THE SHOCK BY HAND. WE TORQUE THE NUT TO 80 INLBS USING A 7/8" CROWS FOOT WRENCH ON A TORQUE WRENCH.



**Part # 11162899**

**1967-1969 GM F-Body, 1968-74 GM X-Body Front Lower StrongArms**



### Recommended Tools

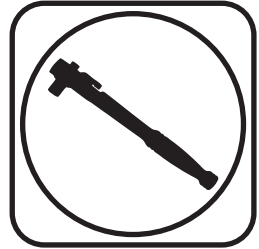

## 1967-1969 GM F-Body Lower StrongArms Installation Instructions

Table of contents	
Page 7.....	Lower Control Arm Components
Page 8.....	Getting Started & Installation
Page 9.....	Installing Spindles and Steering Stop



### Lower Control Arm Components ....In the box

Item #	Part Number	Description	QTY
1	90000621	Driver Lower Control Arm <b>(Shown)</b>	1
1	90000622	Passenger Lower Control Arm	1
2	90000898	Lower Ball Joint Assembly - Proforged # 101-10013	2
3	70010759	Delrin Bushing - with 2" Diameter Ledge	8
4	90002062	CoilOver Bearing Spacers	4
5	90000516	1/2" ID Inner Sleeve	4
6	99501005	1/2"-13 x 3 1/2" Hex Bolt	6
7	99502009	1/2"-13 Nylok Nut	6
8	99503014	1/2" SAE Flat Washer	12
9	99371005	3/8"-16 x 1 1/4" Hex Bolt	2
10	99372012	3/8"-16 Hex Nut	2

Driver Side Shown

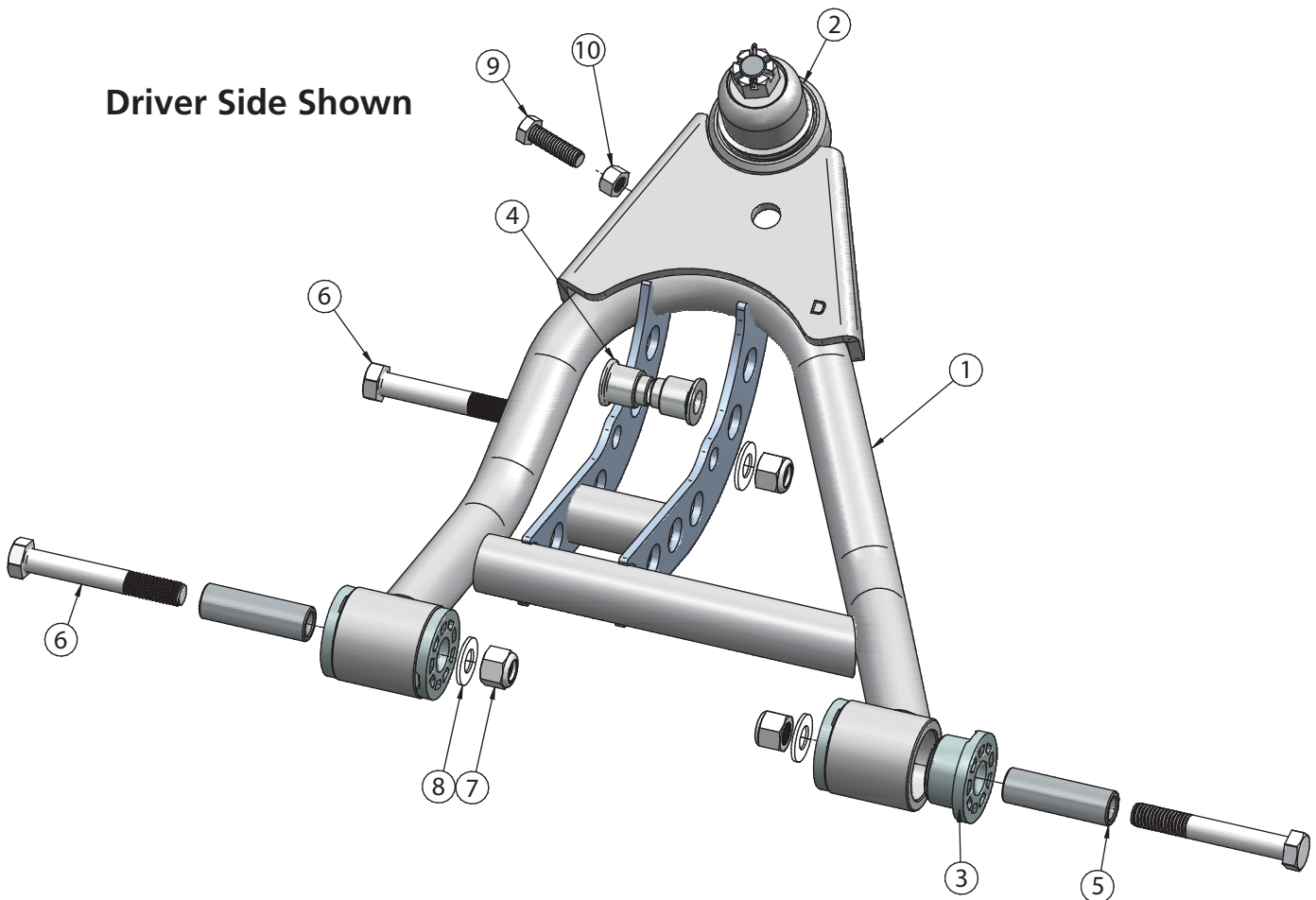



### Getting Started.....

Congratulations on your purchase of the Ridetech F-Body StrongArms. These StrongArms have been designed to give your F-Body excellent handling along with a lifetime of enjoyment. Some of the key features of the StrongArms: Ball joint angles have been optimized for the lowered ride height, Delrin bushings are used to eliminate bushing deflection along with providing free suspension movement through the entire travel. The Geometry has been optimized for excellent handling, and drive ability. The Delrin bushings are made from a material that is self lubricating so no grease zerks are needed.

**Note:** These control arms are designed for use with the Ridetech CoilOvers and the MuscleBar swaybar. **The factory shocks and springs or the factory sway bar will not fit these arms.**

### Installation

1. Remove the entire lower control arms from the car. If you are replacing the upper control arms and spindle, remove them too. Refer to a Factory Service Manual for the proper method.
2. Drill the factory upper shock mounting hole to 3/4". This can be done easily with a Unibit.

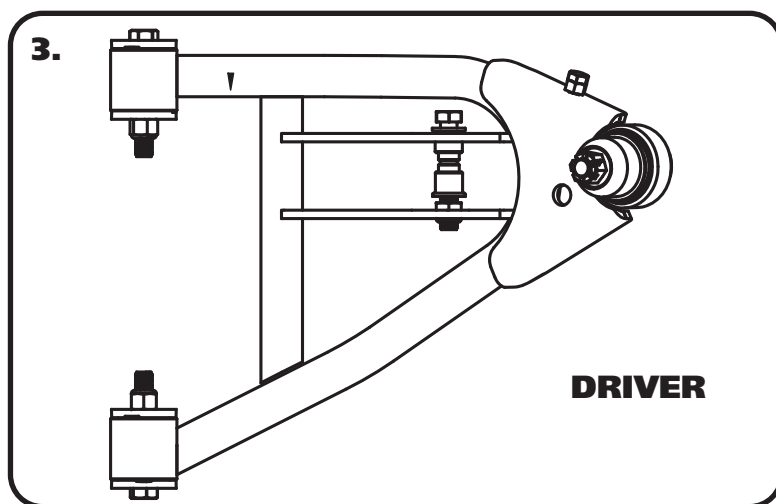

3. After removing the factory lower control arm, clean the bushing mounting surfaces on the frame. The Control Arms are marked "D" for Driver and "P" for Passenger. The Ballpoint Pin points up and the Sway bar mount is on the front side of the arm. Install a 1/2" flat washer on each of (2) 1/2"-13 x 3 1/2" bolts. Insert the bolt/washers through the mounting holes. Install a 1/2" flat washer and 1/2"-13 nylok nut. Torque to 75 ft-lbs.

**Note:** On some cars the frame brackets may be pinched and will need to be spread back apart to allow the bushing to slide in.

**Install the CoilOvers at this time. Refer to the CoilOver instructions for Assembly.**

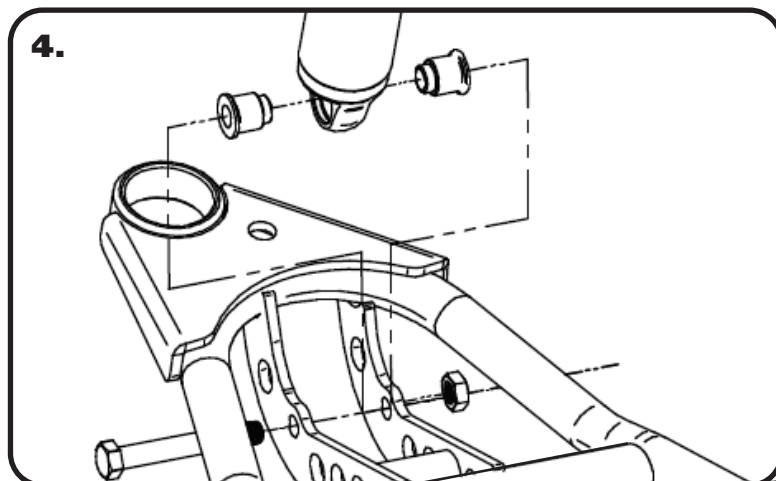

4. Insert the Bearing Spacers into the lower shock bearing. The SMALL end goes into the bearing. Swing the Control Arm up, line up the 1/2" holes with the bearing spacers, insert 1/2"-13 x 3 1/2" bolt. Install a 1/2" flat washer and nylok nut. Torque to 75 ft-lbs. **Note:** The shock bolt will need to be installed from the rear with the threads pointing to the front of the car.



### Installing Spindle & Setting Steering Stop

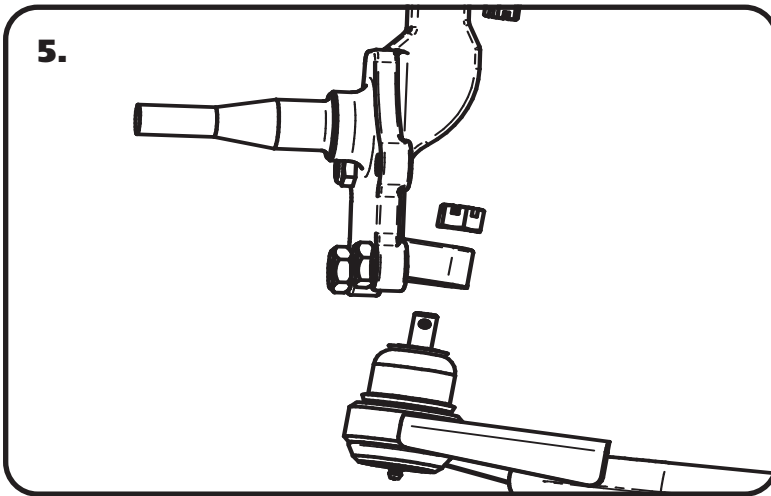

5. Attach the Spindle to the control arms.

**Torque Specs:**

Lower Ball joint - 65 ftlbs and tighten to line up cotter pin.

Install the Cotter Pin after tightening the ball joint nut.



6. Thread the 3/8"-16 nut onto the 3/8"-16 x 1 1/4" bolt. Thread it into the front hole of the ball joint plate. You will need to adjust the steering stop to suite your needs. This setting will vary depending on wheel and tire size and other suspension components. Torque to 12 ft-lbs.

**NOTE:** If you are running the TruTurn setup, this steering stop bolt will not be used.

7. Tighten all fasteners. If you are going to install the Ridetech MuscleBar, now is a good time to do it.

**Suggested Alignment Specs:**

Camber: Street: -.5 degrees  
Caster: Street: +3.0 to + 5.0 degrees  
Toe: Street: 1/16" to 1/8" toe in



**Part # 11163699**

**1967-1969 GM F-Body, 1968-74 GM X-Body Front Upper StrongArms**



### Recommended Tools



## 1967-1969 GM F-Body Upper StrongArms Installation Instructions

### Table of contents

- Page 11..... Upper Control Arm Components
- Page 12..... Getting Started
- Page 13..... Caster Explained
- Page 14..... Offset Upper Control Arm Cross Shaft
- Page 15..... Installing Spindle and Alignment



### Upper Control Arm Components .....In the box

Item #	Part Number	Description	QTY
1	90002390	Driver Upper Control Arm ( <b>Shown</b> )	1
1	90002391	Passenger Upper Control Arm	1
2	90000908 kit	Upper Ball Joint Kit - Proforged # 101-10015	2
3	90003375	Caster Slug Cross Shaft Kit	2
4	70010883	Caster Slug	4
5	70010759	Outer Delrin Bushing with 2" Lip	4
6	70010827	Inner Delrin Bushing with 1.75" Lip	2
7	70010826	Inner Delrin Bushing with No Lip	2
8	90002737	Aluminum T-Washer	4
9	70001323	Bumpstop	2
10	99373003	3/8" SAE Flat Washer - Bumpstop	2
11	99372002	3/8"-16 Nylok Nut - Bumpstop	2
12	99753007	3/4" x 1 3/4" Flat Washer	2
13	99183002	M18 Flat Washer	2
14	99622005	5/8"-18 Jam Lock Nut - Included with 90000914 kit	4
	99433004	7/16" USS Flat Washer - Control Arm Mounting - NOT SHOWN	4

#### Driver Side Shown

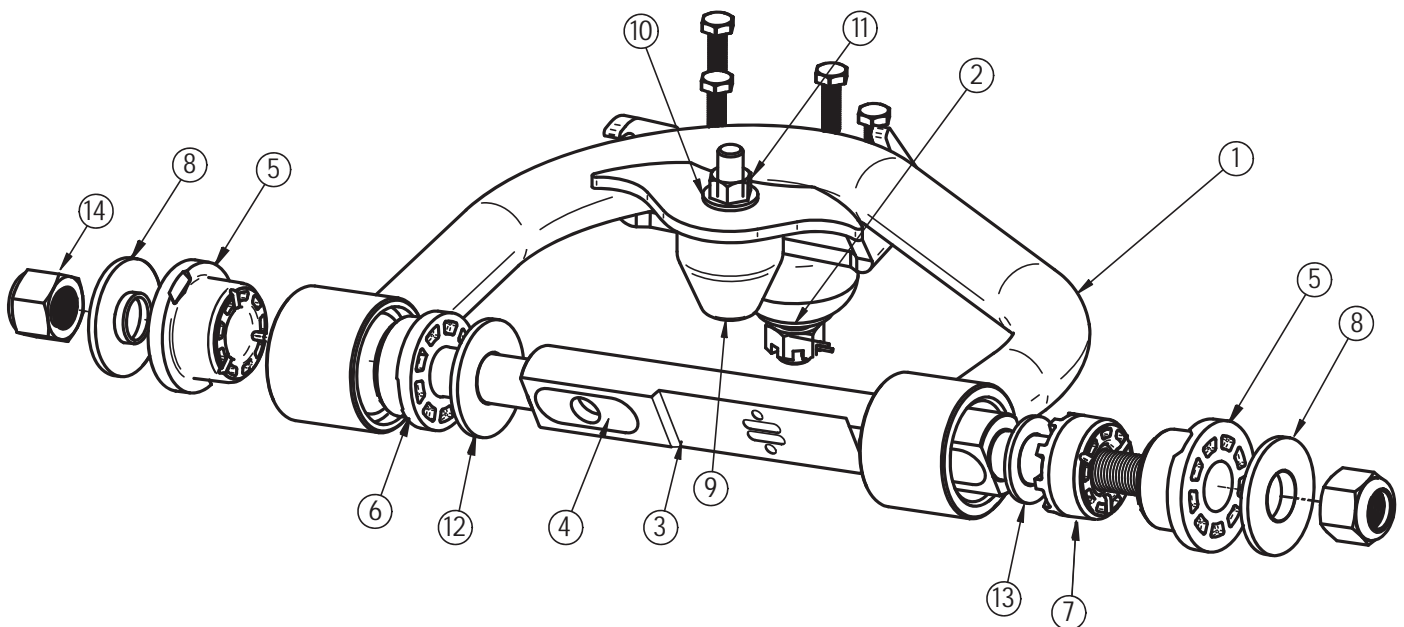



### Getting Started.....

Congratulations on your purchase of the Ridetech F-Body StrongArms. These StrongArms have been designed to give your F-Body excellent handling along with a lifetime of enjoyment. Some of the key features of the StrongArms: Ball Joint angles have been optimized for the lowered ride height, Delrin bushings are used to eliminate bushing deflection along with providing free suspension movement through the entire travel. The Geometry has been optimized for excellent handling and driveability. The Delrin bushings are made from a material that is self lubricating so no grease zerks are needed.

**When assembling the Control Arms tighten the cross shaft nuts enough to create drag on the delrin bushings, the arm should still move through its travel by hand.**

### Installation

1. Remove the entire upper control arms from the car. If you are replacing the lower control arms and spindle, remove them too. Refer to a Factory Service Manual for the proper method.

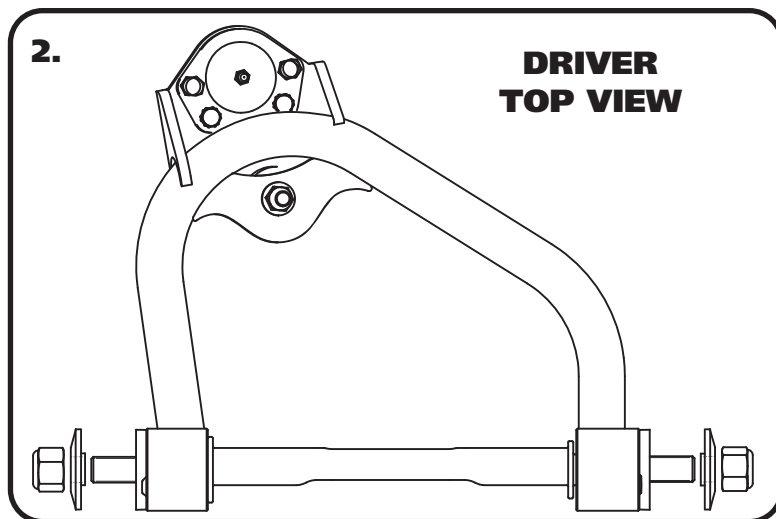

2. The Upper Control Arm is attaching the factory mount using factory hardware. The driver side arm is shown in **Figure "2"**. The Ball Joint located on the arm to the rear of the car. Install the T-Washers and 5/8"-18 Lock Nuts using **Figure "2"** as a reference. These can be tightened after installing the control arms on the car.

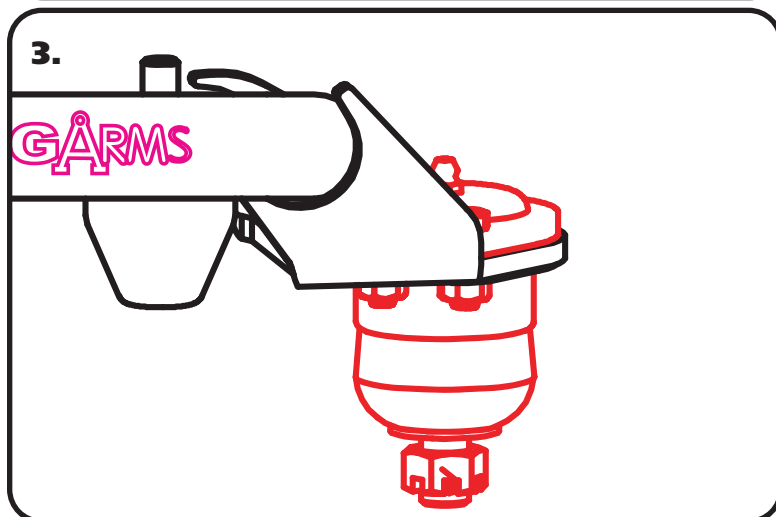

3. Install the Ball Joints in the control arms using **Figure "3"** as a reference. Torque the hardware to 15 ftlbs



### Caster Explained

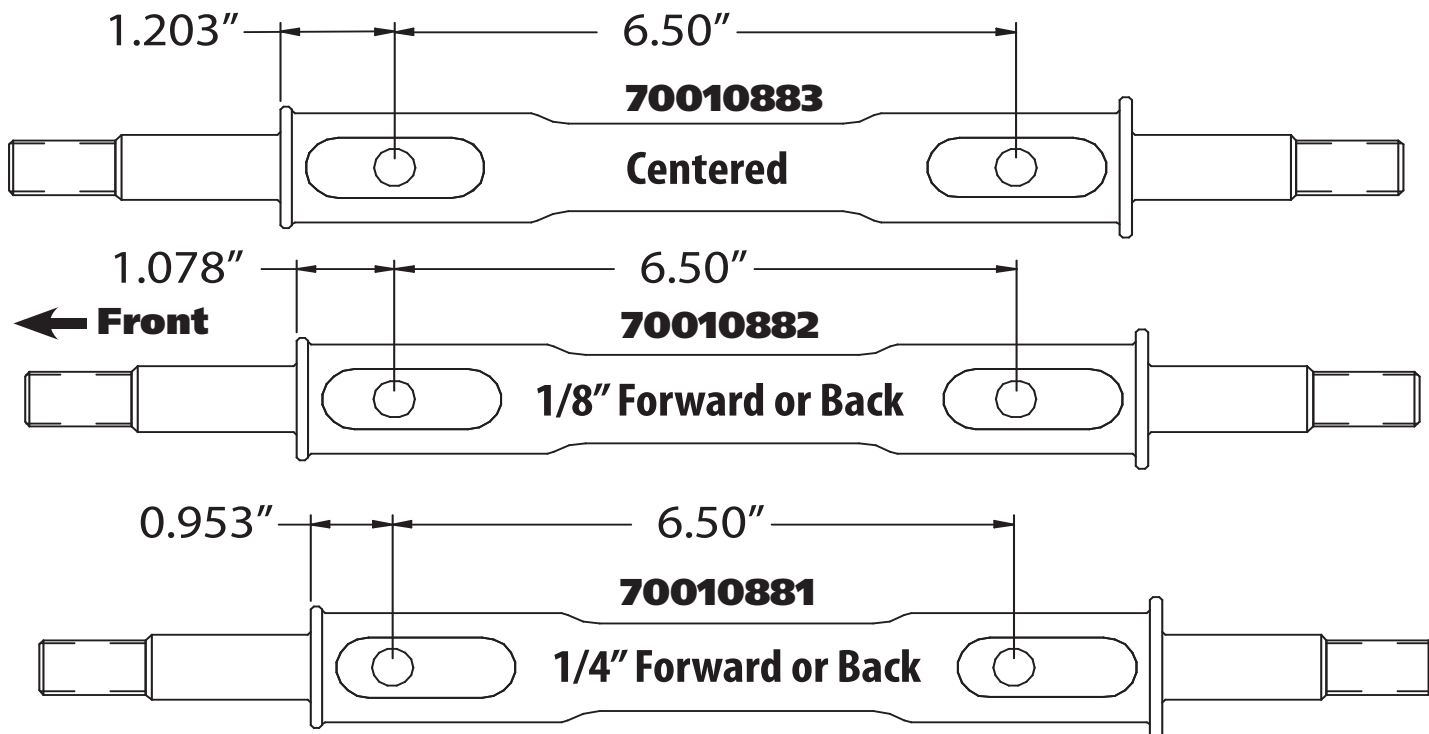

These StrongArms come equipped with a changeable caster slug setup. This allows you to add or remove caster from the front suspension, if desired. The caster slugs that come supplied in the kit are setup to be centered. The caster slugs allow you to add or remove caster without having to use a stack of shims. If more or less caster is desired, optional slugs can be purchased from Ridetech or your Ridetech dealer.

1/8" = 70010882

1/4" = 70010881

### Caster Explained:

To understand caster you need to picture an imaginary line that runs through the upper balljoint and extends through the lower balljoint. From the side view the imaginary line will tilt forward or backward. The tilting of this imaginary line is defined as caster.

Caster is measured in degrees by using a caster gauge. If the imaginary line described above tilts towards the back of the vehicle at the top, then you have positive caster. If the imaginary line tilts forward then you have negative caster.

Positive caster provides the directional stability in your vehicle. Too much positive caster will make the steering effort difficult. Power steering will allow you to run more positive caster. Negative caster requires less steering effort but will cause the vehicle to wander down the highway.



### Offset Upper Control Arm Shaft

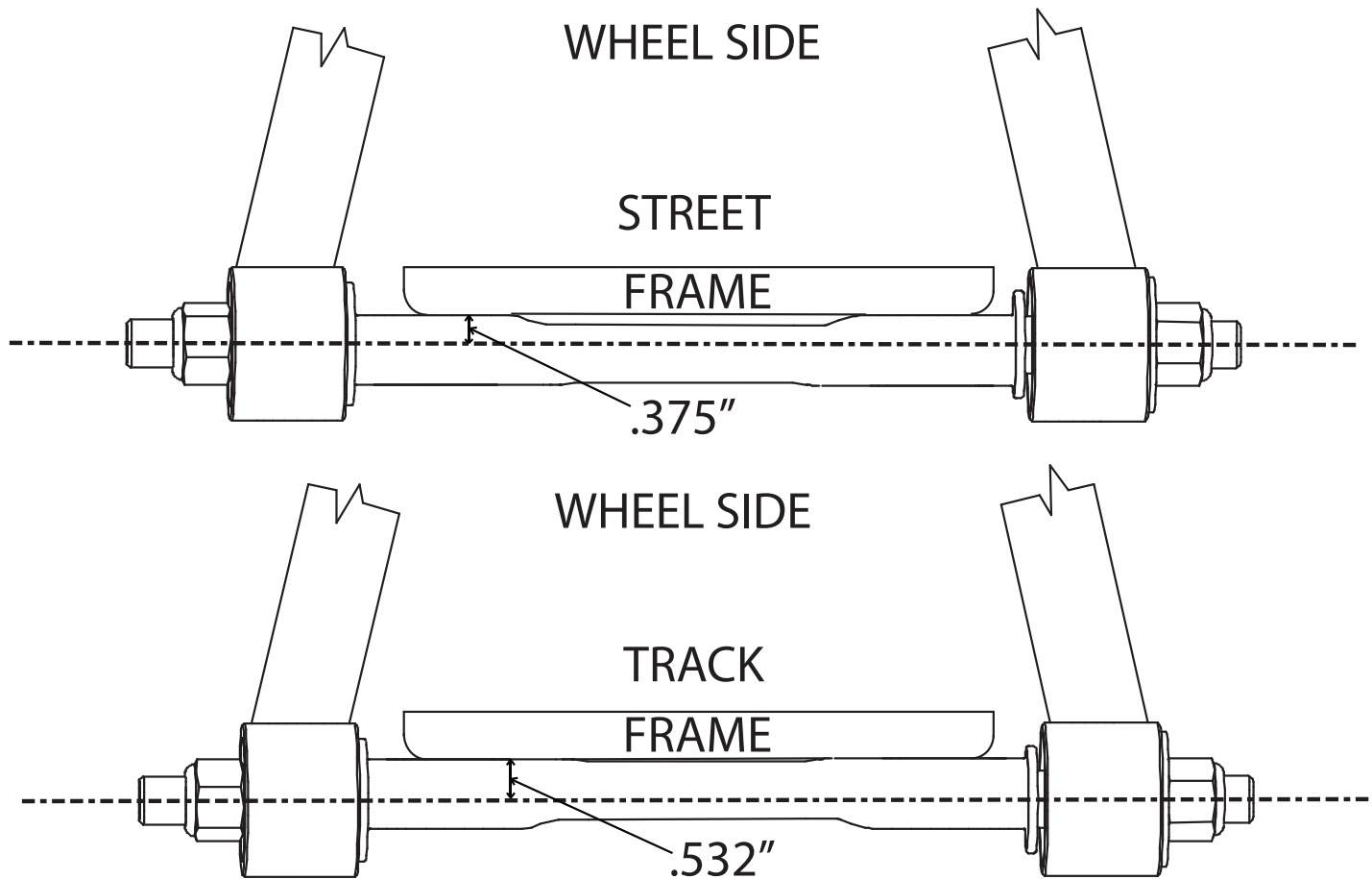

The cross shaft that is used in the upper control arms is offset. The offset combined with the caster slug option allows you to achieve the alignment setting you desire with minimal shims. To change the direction the Icon faces simply spin the cross shaft in the control arm.

If you are after a **Street Alignment** bolt the upper control arm to the frame mount with the arm offset to the outside of the car. The Ridetech Icon and Caster Slugs will be facing the wheel.

If a more aggressive **Track or Autocross** alignment is desired, bolt the control arm to the frame bracket with the arm offset to the inside of the car. The Ridetech Icon and Caster Slugs will be facing the engine.



### Installing Spindle and Alignment



4. The Upper Control Arm is attaching the factory mount using factory hardware with the supplied 7/16" Flat Washer under the OEM Nut. Torque the nuts to 50 ft-lbs. The driver side arm is shown in **Figure "2"**. The Arrow on the Cross shaft points to the front of the car. **Page 4 & 5** has information about Caster and the Caster Slugs.

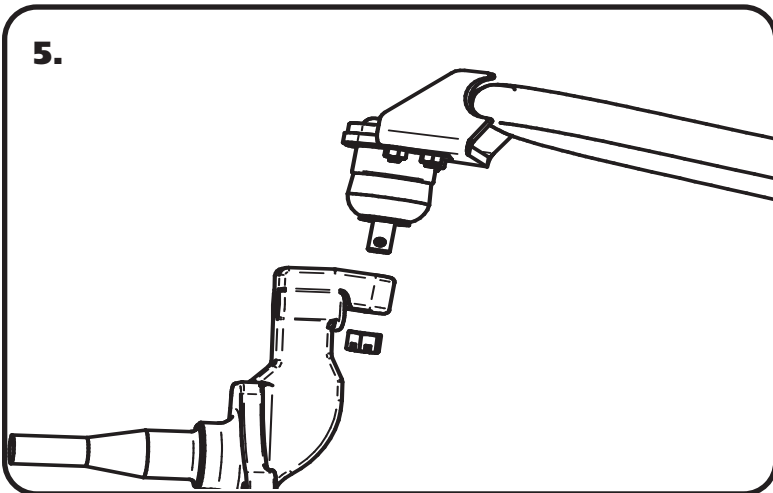

5. Attach the Spindle to the control arms.

#### Torque Specs:

Upper Ball Joint - 50 ftlbs and tighten to line up cotter pin.

Install the Cotter Pin after tightening the ball joint nut.

6. Tighten all fasteners.

**When assembling the Control Arms tighten the cross shaft nuts enough to create drag on the delrin bushings, the arm should still move through its travel by hand.**

#### Suggested Alignment Specs:

Camber: Street: -.5 degrees  
Caster: Street: +3.0 to + 5.0 degrees  
Toe: Street: 1/16" to 1/8" toe in



### Part # 11009303 - A/F/X Tall Spindle Kit



#### Recommended Tools

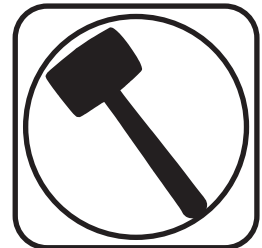
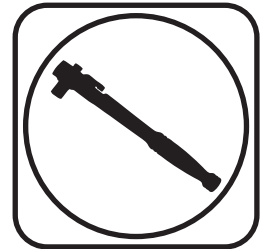

### A/F/X Tall Spindle Kit

# Installation Instructions

#### Table of contents

- Page 17..... Included Components and Hardware
- Page 17..... Getting Started and Installation
- Page 17-18..... Installation
- Page 18..... The Finish

THIS SPINDLE IS DESIGNED TO FIT 64-72 GM A-BODY, 67-69 GM F-BODY, AND 68-74 GM X-BODY. THESE SPINDLES ARE SYMMETRICAL, THEY AREN'T SIDE SPECIFIC UNTIL THE STEERING ARM IS BOLTED ON.

**THESE SPINDLES ARE A DIRECT REPLACEMENT FOR OEM DISC BRAKE SPINDLES. IF YOUR CAR HAS DRUM BRAKES, YOU WILL HAVE TO CONVERT IT TO DISC BRAKES. THEY WILL ACCEPT ANY BRAKE KIT THAT IS DESIGNED FOR THE OEM DISC BRAKES SPINDLES.**



### Major Components .....In the box

Part #	Description	QTY
11009304	Spindles (Pair)	1 pair
90002743	3/4"-20 Spindle Nut Kit	1 kit

Part #	Description	QTY
<b>Hardware KIT # 99010174</b>		
99621001	5/8"-18 X 1" BOLT	2
99501071	1/2"-20 x 3" FSCS	4
99501054	1/2"-20 x 2 1/2" FSCS	2
99502002	1/2"-20 Nylok Nut	6
99502005	1/2"-20 x 2" Bolt	2
99952003	1/8" x 1 1/2" Cotter Pins	4

### Getting Started.....

These spindles will fit '67-69 Camaro, '64-'72 Chevelle, and '68-'74 Nova. They will provide a 2" drop, and are taller than stock to improve the car's cornering ability. The raised upper ball joint induces negative camber gain and positive caster gain. This helps keep the tires flat on the pavement when cornering. This camber action change also raises the roll center for less body roll, and transfer the car's center of gravity inboard in the turn as well. You will see an appreciable improvement in handling.

These spindles are designed around stock disc brake spindles and will accept any disc brake set up designed for those. **The only modification we discovered to be necessary, was a small trim on the bottom of the stamped 1/4" steel caliper bracket that holds the caliper.** It is an area that is not stressed and will not cause any loss of strength. Trim only enough to make the caliper bracket clear the spindle. If you are using the factory dust shields, they will also require trimming. If your car came with drum brakes, be sure to swap to the appropriate disc brake master cylinder and valving.

### Installation



**IF YOU HAVEN'T ALREADY DONE SO, REMOVE THE OEM SPINDLE. IF REUSING THE EXISTING CALIPERS, BE SURE TO SUPPORT THEM TO KEEP FROM PUTTING UNWANTED STRESS ON THE BRAKE LINES.**

1. The steering arm will bolt to the **BOTTOM** set of holes in the Ridetech spindle using the supplied 1/2" hardware. The mounting bosses of the steering arm are 2 different thicknesses. The uses a 1/2"-20 x 3" flat socket cap screw. The thin boss will use a 1/2"-20 x 2 1/2" flat socket cap screw.



### Installation



**NOTE:** Some steering arms have 7/16" mounting holes, they will need to be drilled out using a 1/2" drill bit.

**2.** Line up the steering arm mounting holes with the bottom 2 holes of the spindle. Insert the 3" long bolt through the thick boss and the 2 1/2" long bolt through the thin boss, inserting the bolts from the front of the spindle. Slip the steering arm onto the bolts. Install a 1/2"-20 nylok nut on each bolt. The steering arm hardware will need to be torqued to 100 ftlbs, but it is easier to torque with the spindle installed on the car.

### The Finish

**3.** Attach the spindles to the control arms. Torque the ball joints and tie rods end using the torque specs below.

#### Torque Specs:

Lower Ball Joint -	65 ftlbs and tighten to line up cotter pin.
Upper Ball Joint -	50 ftlbs and tighten to line up cotter pin.
Tie Rod End -	35 ftlbs and tighten to line up cotter pin.

#### Wheel Bearing Tightening:

While turning the rotor, tighten the nut to 12 ftlbs with a torque wrench. Back off the nut one flat and insert the cotter pin. If the slot and pin hole don't line up, back off the nut an additional half flat or less as required to insert the pin. Note: Bearings should have zero preload and .001" to .008" of end movement. Bend the ends of the cotter pin, replace the dust cap. On a disc brake with the caliper removed, it's normal to have a slight amount of play detectable in the bearing.

**5.** Recheck all hardware before driving.

**6. PUMP THE BRAKE PEDAL BEFORE DRIVING TO RESET THE BRAKE PADS TO THE ROTOR. IF YOU HAD THE CALIPERS REMOVED, BLEED THE BRAKE SYSTEM.**

#### Suggested Alignment Specs:

Camber:	Street: -.5 degrees
Caster:	Street: +3.0 to + 5.0 degrees
Toe:	Street: 1/16" to 1/8" toe in



**Part # 11169120 - 1967-1969 GM F-Body Front Sway Bar**



**Recommended Tools**

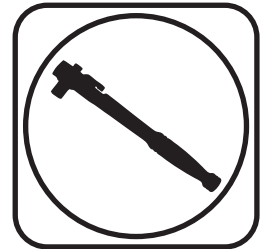

# 1967-1969 GM F-Body Front Sway Bar Installation Instructions

Table of contents  
Page 20..... Included Components and Hardware List  
Page 20-21.... Sway Bar Installation

Hardware Torque Specifications  
5/16"-16..... 17 ftlbs

# Major Components .....In the box

Part #	Description	QTY
90001234	Front Sway Bar	1
90002929	End Link Kit	2
90001344	Billet Bushing Strap	2
70015013	Lined Sway Bar Bushing	2
<b>HARDWARE</b>		
99311030	5/16" -18 x 1" Hex Bolt	4
99313001	5/16" SAE Flat Washer	4
99313005	5/16" Split Lock Washer	4

## Getting Started.....

**Note:** This sway bar kit utilizes a anti-friction lining in the sway bar bushing. The lining allows the sway bar to move freely and quietly in the bushing. No lubrication is required.

1. Jack the vehicle up to a safe working height and support with jack stands. Make sure the jack stands are stable before working under the car.
2. Remove the driver front wheel/tires. It will be required to get the swaybar installed
3. Remove the stock sway bar.



4. Open the sway bar bushing at the split and slip it **OVER** the sway bar. Do this for both bushings



5. Insert the sway bar in the stock location. See below for installation tips.

**Installation Tips:** It is easier to install if you have the driver wheel/tire removed. Turning the steering wheel to the left also helps. It will require some twisting and turning of the bar to work it through the frame into the stock location. The swaybar needs to end up in the stock location with the ends above the lower control arms.



6.

6. Slip the bushing straps over the sway bar bushings. Line them up with the OEM mounting holes.



8.

7. Install a 5/16" lock washer & 5/16" flat washer on the 5/16" x 1" hex bolts.



8.

8. Torque the mounting hardware to 17 ftlbs.

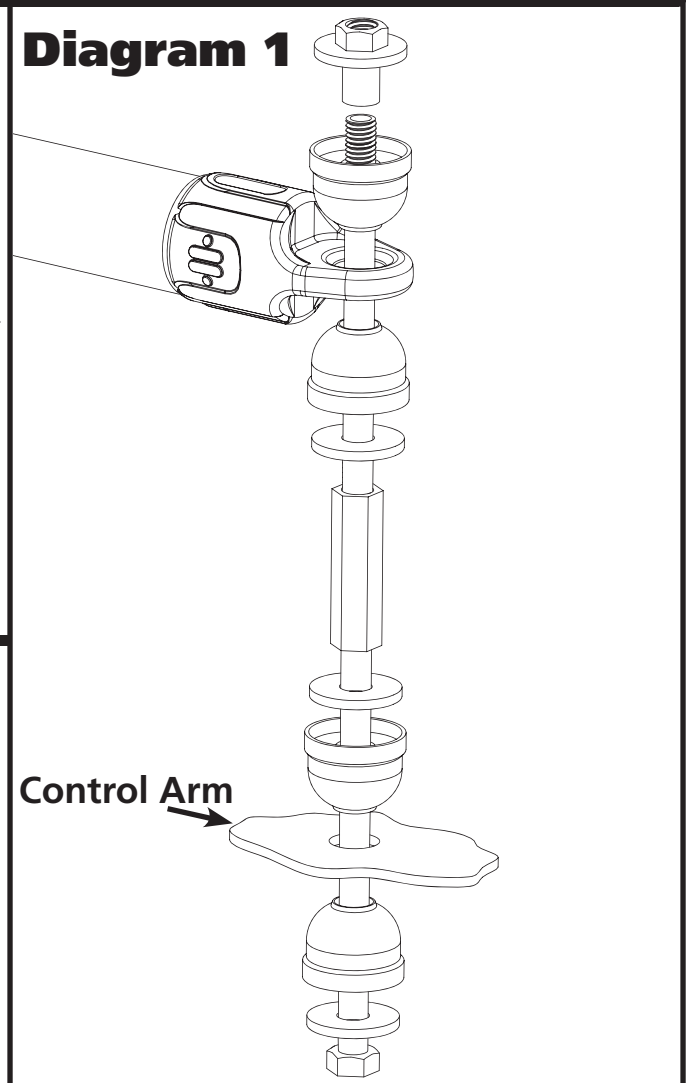

**Diagram 1**

**Control Arm**



9.

9. Install the end links using **Diagram 1** as a reference. Install both end links before tightening the end link hardware. Tighten the end link barrel nut until it is flush with the end of the bolt, and then tighten it 2 more complete rounds.



### Part # 11267199 -1968-1974 GM "X" Body Rear R-Joint Bolt-in 4 Link



#### Recommended Tools

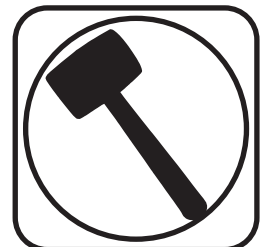
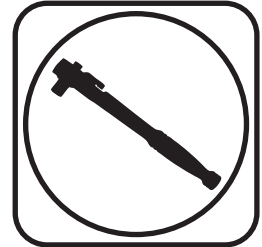

## 1968-1974 GM "X" Body Rear Bolt-in 4Link Installation Instructions

#### Table of contents

Page 23-24.....	Included Components
Page 25.....	Hardware List & Getting Started
Page 26.....	OEM Variation
Page 26-31.....	Cradle Installation
Page 31.....	Lower Bar Installation
Page 32.....	Lower Bar & Shock Mount Installation
Page 33.....	Attaching Lower Shock Mount & Lower Bar
Page 34.....	Installing Lower Bar
Page 35.....	Setting Pinion Angle
Page 36.....	Upper Bar Axle Tab Installation
Page 37.....	Installing Axle Tabs
Page 38.....	Installing ShockWaves/CoilOvers





### Major Components .....In the box

Item #	Part #	Description	QTY
1	90002879	Upper Cradle	1
2	90003367	Forward Tab Inner Brace	2
3	90002077	Lower Axle Mount - Driver	1
4	90002078	Lower Axle Mount - Passenger	1
5	90002860	Lower Bar Assembly - 24 3/4" center to center	2
6	70013537	Front R-Joint Spacer	2
7	90001318	RH R-Joint Threaded Housing End (installed in bars)	2
8	90003411	Upper Bar - 8 5/8" center to center set length	2
9	70013334	R-Joint Spacers	14
10	70013049	Inner Upper Bar Tab - Driver	1
11	70013050	Inner Upper Bar Tab - Passenger	1
12	70013051	Outer Upper Bar Tab	2
13	70013052	Axle Tab Rear Brace	2
14	90001624	Aluminum Lower Shock Mount	2
15	70002825	Lower Shock Stud	2
16	90002067	Lower Shock Spacers	4
17	99752004	RH 3/4"-16 Jam Nut (installed on bar ends)	2
	85000008	Riv-Nut Installation Tool (NOT SHOWN)	1
	70010694	Bar Tab Setting Jig (NOT SHOWN)	2
	99371050	3/8"-16 x 1 1/2" Conical Body Bolt (NOT SHOWN)	6
	99372009	3/8"-16 U-Nut (NOT SHOWN)	6
<b>R-Joint Components - (Installed in bar ends)</b>			
	70013279	Retaining Ring	6
	70013280	Wavo Wave Spring	6
	70013275	R-Joint Center Ball	6
	70013276	R-Joint Composite Center Ball Cage	6

New R-Joints will be quite stiff (75-90 in/lbs breakaway torque) until they "break in" after a few miles of use. After the break in period they will move much more freely. Because the composite bearing race contains self lubricating ingredients, no additional lubrication is needed or desired. Any additional lubrication will only serve to attract more dirt and debris to the R-Joint and actually shorten its life.



### Major Components .....In the box

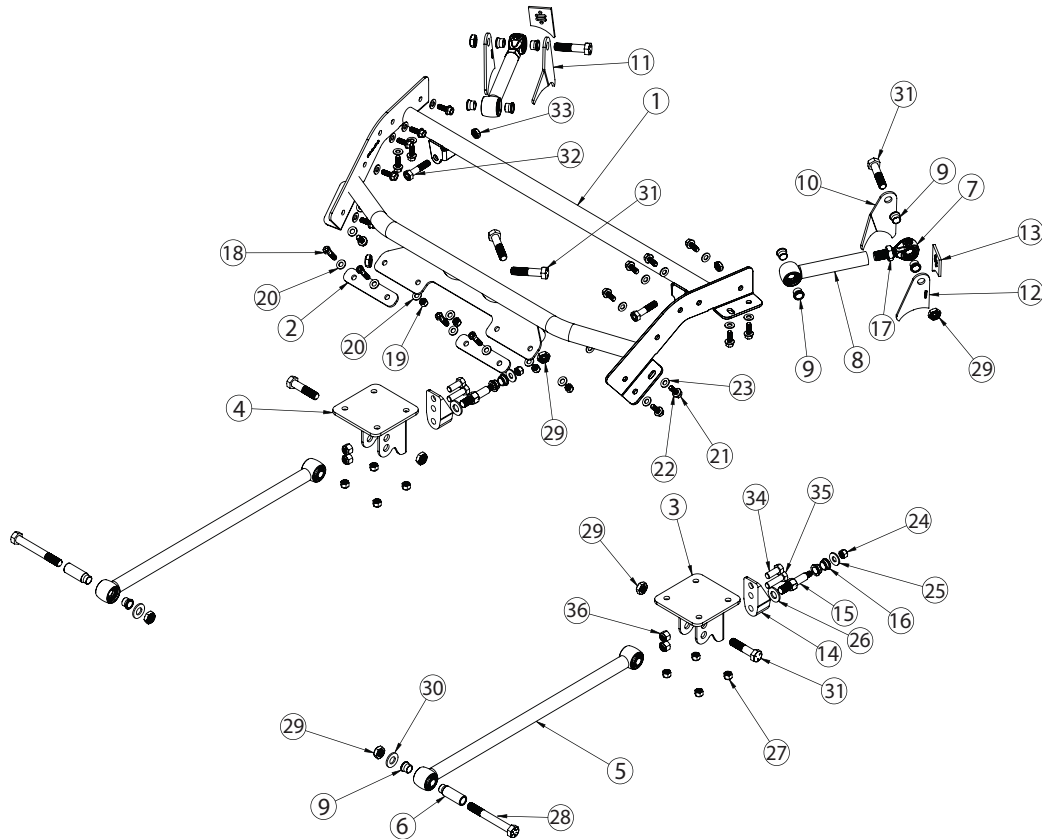

#### R-JOINT SPACER INSTALLATION

Install the Spacers by inserting the SMALL side of the SPACER into the Center Pivot Ball. Push them in until they bottom out and stop.

#### LOWER FRONT R-JOINT

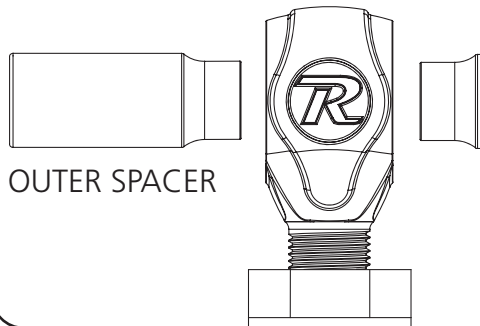

#### ALL OTHER R-JOINTS

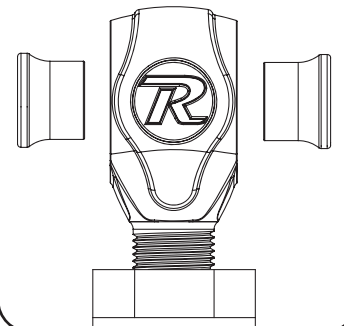

New R-Joints will be quite stiff (75-90 in/lbs breakaway torque) until they "break in" after a few miles of use. After the break in period they will move much more freely. Because the composite bearing race contains self lubricating ingredients, no additional lubrication is needed or desired. Any additional lubrication will only serve to attract more dirt and debris to the R-Joint and actually shorten its life.



### Hardware List .....In the box (Kit# 99010210)

The Hardware Kit contains bags to help aid in selecting the correct hardware for the component being installed. The hardware list shows how the hardware is bagged.

Item #	QTY	Part Number	Description	Item #	QTY	Part Number	Description
<b>CRADLE - FRONT TAB</b>				<b>LOWER BAR - FRONT MOUNTING</b>			
18	4	99371006	3/8"-16 x 1 1/2" Hex Bolt	28	2	99621007	5/8"-18 x 5" Hex Bolt
19	4	99372002	3/8-16" Nylok Nut	29	2	99622006	5/8"-18 Nylok Jam Nut
20	8	99373003	3/8" SAE Flat washer	30	4	99623001	5/8" Flat Washer
<b>CRADLE MOUNTING</b>				<b>4 LINK BARS</b>			
21	16	99371005	3/8"-16 x 1 1/4" Bolt	29	6	99622006	5/8"-18 Nylok Jam Nut
22	16	99373006	3/8" Split Lock Washer	30	12	99623010	5/8" SAE Flat Washer
23	16	99373002	3/8" SAE Flat washer	31	6	99621004	5/8"-18 x 3" Gr. 8 Bolt
	16	99372007	3/8"-16 Riv-Nut	<b>SHOCK MOUNT &amp; SHOCK MOUNTING</b>			
	1	85000007	17/32" Drill Bit	32	2	99501026	1/2"-13 x 2 1/4" Hex Bolt
<b>SHOCK STUD</b>				33	2	99502007	1/2"-13 Thin Nylok Jam Nut
24	2	99432002	7/16"-20 Nylok Nut	34	2	99501019	1/2"-13 x 1 1/4" Hex Bolt
25	2	99433002	7/16" SAE Flat Washer	35	2	99501046	1/2"-13 x 1 3/4" Hex Bolt
26	2	99623004	5/8" SAE Flat Washer	36	4	99502001	1/2"-13 Nylok Nut
<b>LOWER BAR MOUNT TO AXLE</b>				<b>UPPER 4 LINK TAB SETTING JIG</b>			
27	8	99432007	7/16"-20 Nylok Nut	37	2	99371001	3/8"-16 x 3/4" Hex Bolt
				38	2	99372004	3/8"-16 Hex Nut

## Getting Started.....

Congratulations on your purchase of the Ridetech Rear 4-link System. This system has been designed to give your X-Body excellent handling along with a lifetime of enjoyment. This kit replaces the Leaf Springs, this allows the 4-Link to locate the rearend and the CoilOvers/ShockWaves to support the car. This allows each to be optimized for the best performance.

**Note:** These system is designed for use with the Ridetech Shockwaves or CoilOvers. **The factory shocks and springs will not fit this setup.**

1. Raise the vehicle to a safe and comfortable working height. Use jack stands to support the vehicle with the suspension hanging freely. You will need a method of raising and lowering the differential.
2. Support the axle and remove the leaf springs, shocks, pinion snubber, and tail pipes. Refer to the factory service manual for proper disassembly procedures. Retain the front leaf spring mounts, they will be used with the 4 link. You may need to detach the fuel line from the frame rails. The back seat of the car will also need removed for installation of the 4 link cradle.



### 73-74 Frame Rail Variations



1973 & 1974 can have 2 different rear frame rail variations. If yours looks like the image on the left, you have the correct kit. If your frame rail has a hump similar to the one circled in the right image, you need kit # 11267159. Please contact customer service if you have the incorrect kit.

### OEM Variation

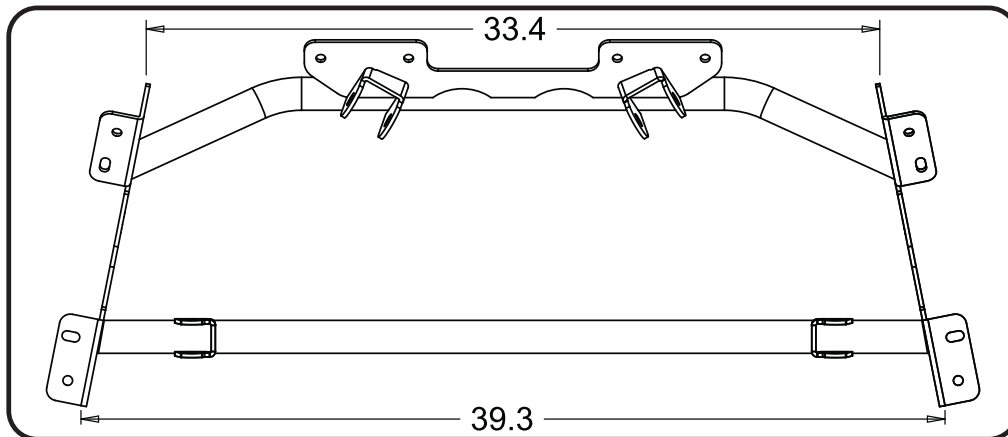

**Note:** In rare cases, the dimension from frame rail to frame rail on your X-Body may vary from the dimension on the Ridetech Upper Cradle. **ALL** of the Ridetech Upper Cradles are jig built to the dimensions above. The variation in OEM manufacturing specs does happen and is out of our control. If your X-Body frame rails seem out of spec, feel free to contact our Tech Department at 812-482-2932 and we will try to offer some solutions.

### Cradle Installation



3. Remove the factory pinion snubber from the car by removing the (2) retaining bolts.



### Cradle Installation

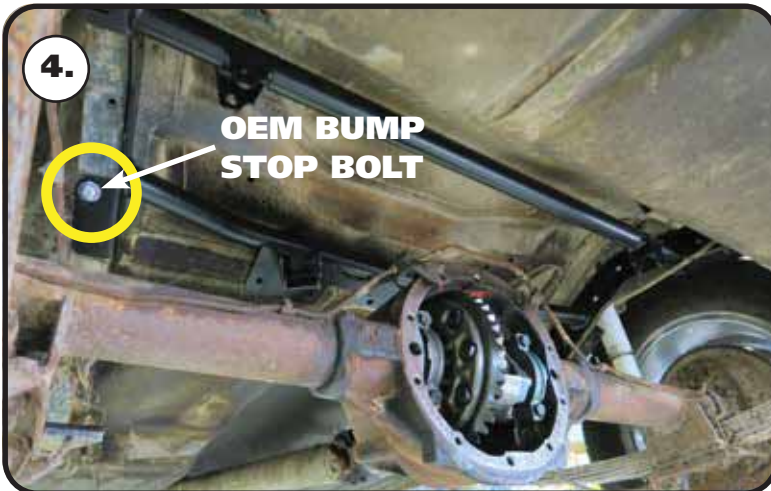

**4. Steps 5-14 cover mounting the cradle into the car, review all steps.** Lower the axle enough to slide the upper cradle into place. On most cars the location of the cradle will index off of the factory bump stop bolt hole. If your car has the bump stop beside the frame, slide the cradle forward until the front tube touches the body. **Image 4 shows the cradle installed in the car.**

**Note:** The OEM fuel line may need to be detached from the frame rails until the cradle is installed.

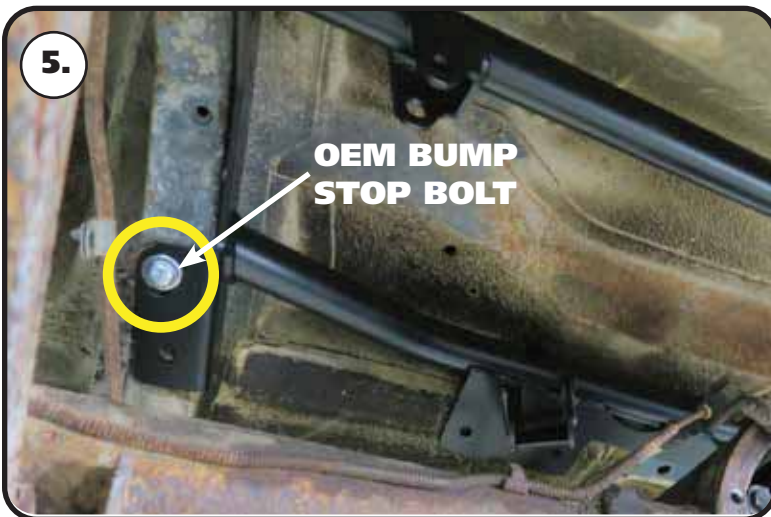

**5.** Install the cradle into the car. When the cradle is positioned properly, the front bar should be up against the body, the front tab will be up against the bottom side of the seam.

**THE CRADLE WILL GET TEMPORARILY BOLTED IN BY THE FRONT TAB AND OEM BUMP STOP HOLE. IT WILL GET REMOVED TO DRILL AND INSTALL THE RIV-NUTS IN THE FRAME RAILS.**



**6. Image 6** shows how the front tab overlaps the body seam. Multiple pieces of the car body overlap at this joint making it a strong area to attach to. **We recommend removing the back seat before drilling these holes.** Drill these 4 holes with a 3/8" drill bit using the cradle as a template.



### Cradle Installation



**7.** The kit includes (2) backing plates for the front tab. These backing plates are installed in the inside of the car. The rear seat should have already been removed before the holes were drilled. Lay the backing plates on the seam, lining up the 2 holes drilled in the previous step. Install a 3/8" flat washer on each of (2) 3/8"-16 x 1 1/4" hex bolts.



**8.** Do this for both backing plates. There should be a plate on each side of the drive shaft tunnel.



**9.** Install a 3/8" flat washer followed by a 3/8"-16 nylok nut on threads of each of the bolts sticking through the front tab.



### Riv-nut® Installation & Specs

1. Drill hole in frame using the SUPPLIED DRILL BIT keeping the drill square with the metal.
2. We recommend installing (2) 3/8" flat washers between the bolt head and the lower anvil of the installation tool. Thread a Riv-nut® onto the supplied Tool. Thread the Riv-nut all the way onto the tool until it stops.
3. Insert the tool and Riv-nut® into the drilled hole 90° to the frame rail.
4. The tool requires (1) 9/16" & (1) 5/8" wrenches to use. A ratchet can be used on the top of the tool.

#### KEEP THE TOOL AND RIV-NUT 90° TO THE SURFACE WHILE TIGHTENING

5. Put a 5/8" wrench on the lower hex of the tool. Use a wrench or ratchet on the top hex to tighten.
6. Hold the wrench in one position and turn the TOP HEX CLOCKWISE to engage the Riv-nut®. Keep turning the TOP WRENCH until you feel a positive stop and you can't turn the TOP WRENCH anymore.
7. Break the tool loose by turning the TOP HEX counterclockwise and thread the tool out of the Riv-nut®

#### THE DATA BELOW ILLUSTRATES THE STRENGTH OF THE RIV-NUT®

#### RIVNUT® Fastener Engineering Data

Upset Load (lbs.)		
RIVNUT * Size	Steel	
	Min. Grip	Max. Grip
3/8-16	4965	5325

Fig. 1

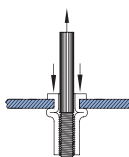

Ultimate thread strength (lbs.)		
RIVNUT * Size	Steel	
	Min. Grip	Max. Grip
3/8-16	11500	10450

Fig. 2

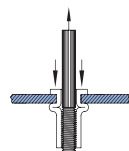

Ultimate tensile strength (lbs.)	
RIVNUT * Size	Steel
3/8-16	3900

Fig. 3

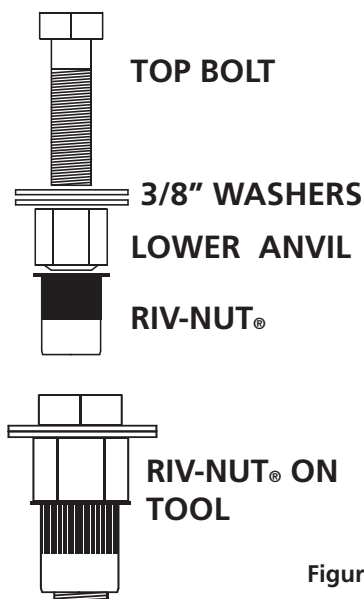
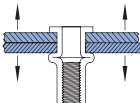

Figure 2

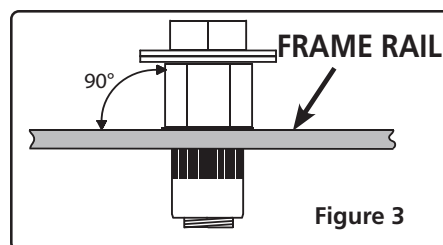

Figure 3

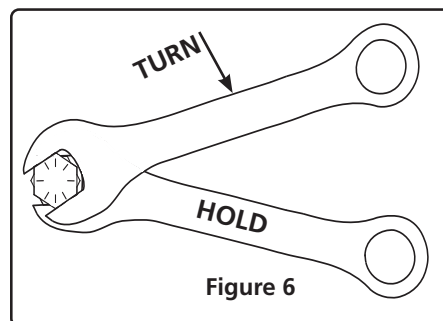

Figure 6

**Single Shear Strength 3/8" Grade 5 Bolt  
3,975.8 lbs**



### Cradle Installation



**10.** Mark the holes of the frame mounts. Mark the slotted holes in the center of the slot. These holes use Riv-nuts to bolt the cradle to the frame. The holes need to be centered as much as possible. Make sure to mark all (9) holes in each frame rail.



**11.** Remove the cradle to drill the holes and install the Riv-nuts. The holes for the Riv-nuts **NEED** to be drilled with the supplied 17/32" drill bit. We suggest drilling the holes with a smaller drill bit first to make it easier to drill with the 17/32" drill bit. Drill all (18) holes in the frame rails.



**12.** Install the Riv-nuts in the frame rails. **Refer to the Riv-nut installation instructions on PAGE 8 for proper Riv-nut installation.** **Image 12** illustrates a Riv-nut being installed. Install all (16) Riv-nuts in the frame rails.



### Cradle Installation & Lower Bar Mount



13. After you get all the riv-nuts installed, reinstall the cradle in the car. The bolts for the front tab can be reinstalled. Leave everything loose until all the bolts are started.



14. Install a 3/8" split lock washer & 3/8" flat washer on each of the 3/8"-16 x 1 1/4" bolts supplied in the kit. Thread them into the riv-nuts. Torque to 23 ft-lbs. Torque the front tab and sway bar tab hardware to 30 ft-lbs.



15. The R-joint setup is designed to be offset to the inside of the car. The bolt hole in the mounting bracket has to be drilled out to 5/8" and the new 5/8" x 5" bolt, washers, & 5/8" thin nylok nut are used. The wider spacer is used on the outside with a narrow spacer on the inside. This will offset the bar to the inside of the car for better wheel and tire clearance. The bolt needs to go in the bracket like seen in the picture. The threads of the bolt must be pointing to the OUTSIDE of the car. Shown in **Image 15** is the driver side bar and mount. Repeat on both sides and tighten the bolts/nuts enough to eliminate any gaps.



### Lower Bar & Shock Mount Installation



**16.** Attach the lower bar/mount assembly to the car. New 3/18"-16 u-nuts and 3/8-16" x 1 1/2" conical body Bolts are supplied in the kit. Install the u-nuts in place of the OEM u-nuts. Hold the assembly in place lining up the holes with the u-nuts. There is a tab bent up on the mount that indexes into a hole in the body. Make sure the tab is indexed into the alignment hole. Torque the mounting bolts to 30 ft-lbs.

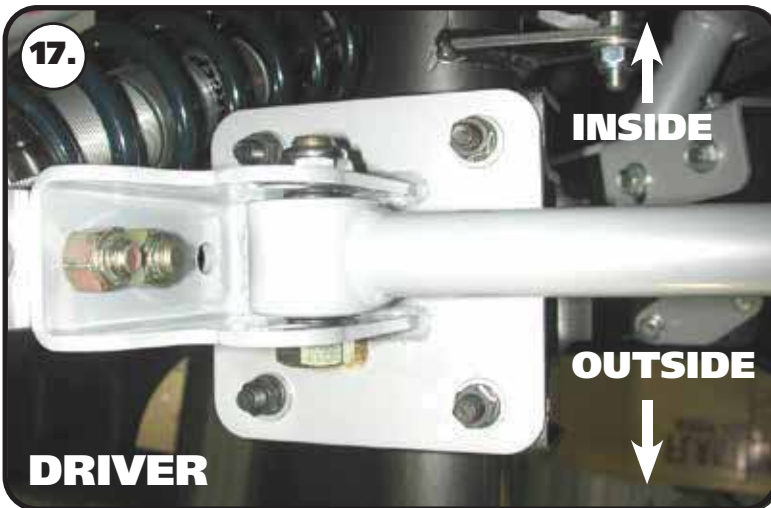

**17.** The lower axle bracket will be fastened to the leaf spring pad using the factory T-bolts/ U-bolts. The bar mount is offset to the inside of the car to provide more wheel and tire clearance. New 7/16" nyloks are supplied. Torque the nuts to 55 ftlbs.

Image 17 shows the Driver side.

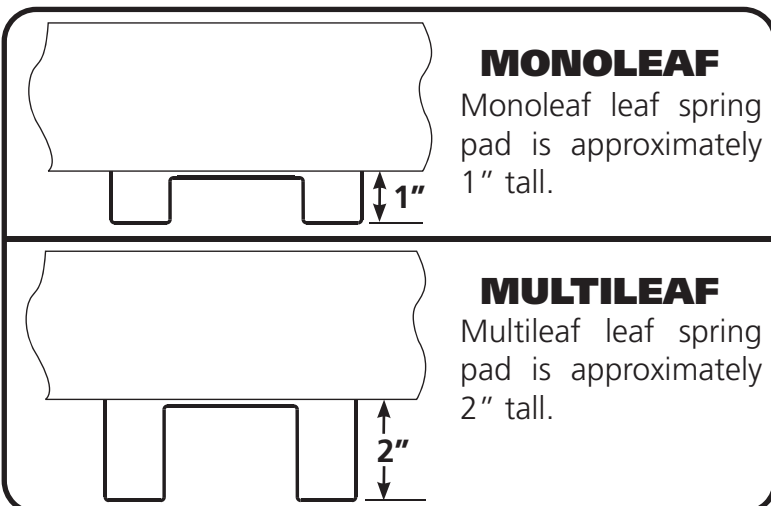

The 68-74 X-body could come with either a Monoleaf spring or Multileaf spring. We provided this guide to help you determine which leaf spring mount your car has. Steps 18 & 19 cover bolting the lower shock mount to the axle bracket. You need to know which leaf spring mounts you have to determine how the shock mount needs bolted to the axle mount. Image 18 shows the Multileaf, Image 19 covers the Monoleaf. The leaf spring mount on each of the rear differentials are different heights requiring the lower shock mount be attached in different locations depending on the leaf spring mount. The lower mount attaches with (1) 1/2"-13 x 1 1/4" hex bolt, (1) 1/2"-13 x 1 3/4" Hex Bolt, & (2) 1/2"-13 nylok nut.



### Attaching Lower Shock Mount & Lower Bar

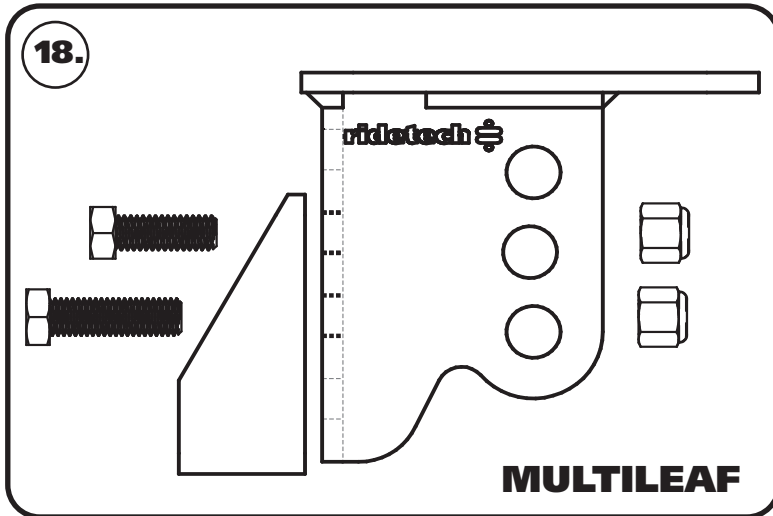

**18. MULTILEAF** - The Multileaf setup uses the **MIDDLE 2 HOLES** for mounting. Insert the bolts through the aluminum shock mount with the 1 1/4" long bolt in the top bolt, 1 3/4" in the bottom hole. Insert the bolts through the axle mount and install the nylok nuts on the threads sticking through. Repeat on both sides and torque the bolts/nuts to 75 ftlbs. Skip to **Step 20**.

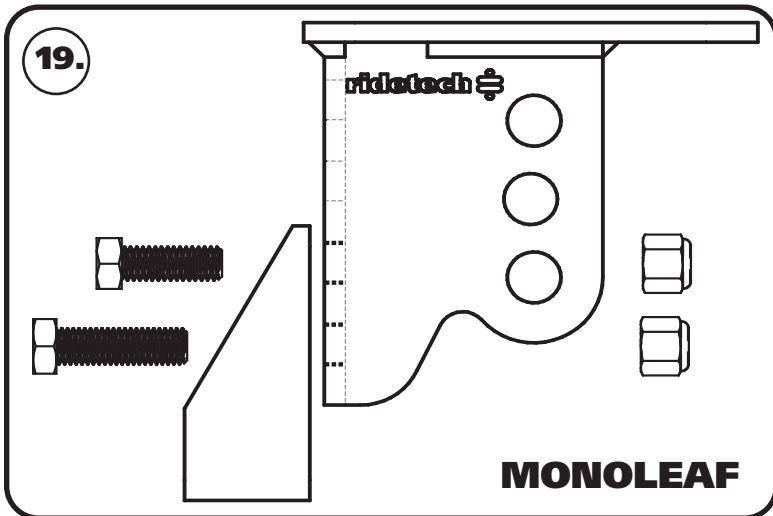

**19. MONOLEAF** - The Monoleaf setup uses the **BOTTOM 2 HOLES** for mounting. Insert the bolts through the aluminum shock mount with the 1 1/4" long bolt in the top bolt, 1 3/4" in the bottom hole. Insert the bolts through the axle mount and install the nylok nuts on the threads sticking through. Repeat on both sides and torque the bolts/nuts to 75 ftlbs.

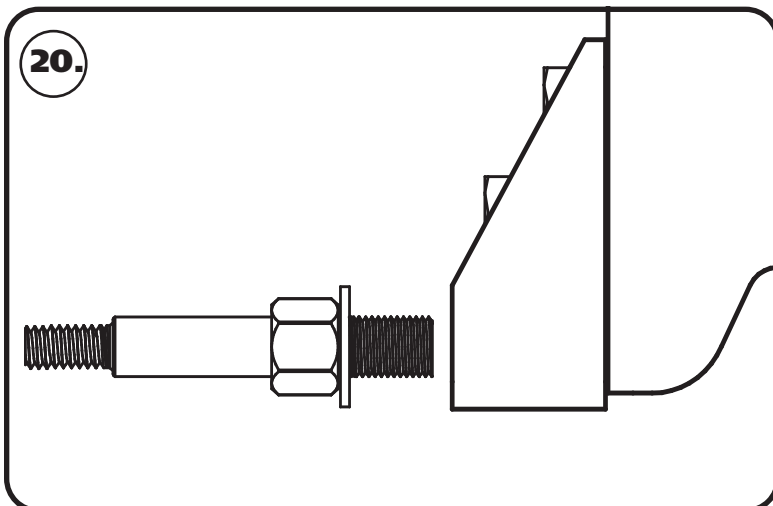

**20.** Installing the shock stud into the lower mount. Install a 5/8" flat washer onto the 5/8" - 18 threads of the shock stud. Apply Red Loctite to the 5/8" threads of the stud. Thread the shock stud into the threaded hole of the lower mount. Repeat on both sides and torque the shock stud to 65-75 ftlbs.



### Installing Lower Bar

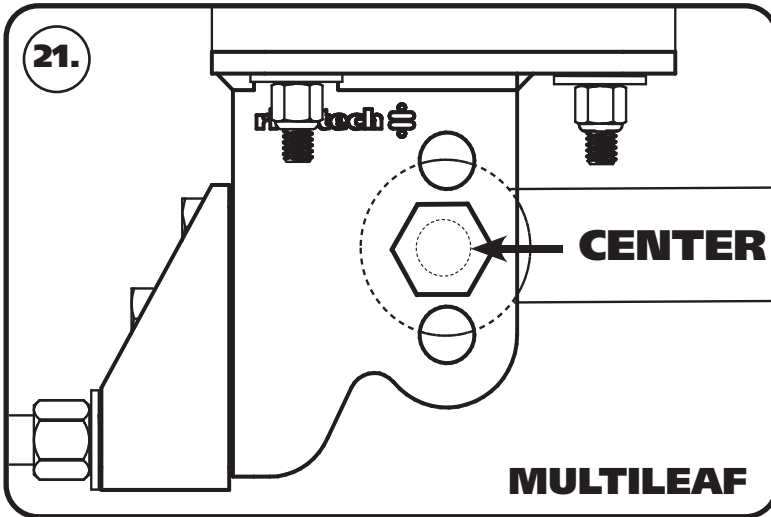

**21. Images 21-23** illustrate attaching the lower bar to the axle mount. Image 21 shows the Multileaf, Image 22 covers the Monoleaf, Image 23 shows a bottom view. The different heights of the leaf spring pads of the differentials require the lower bars to be mounted in the correct hole to optimize the geometry of the 4 link bars. A 70013334 spacer will need to be installed on each side of the R-Joint with the SMALL OD inserted into the R-joint center ball. Use **Image 23** as a reference. The lower bar attaches with (1) 5/8"-18 x 3" hex bolt, (2) 5/8" flat washers, & (1) 5/8"-18 nylok jam nut. **MULTILEAF** - The Multileaf setup uses the MIDDLE HOLES for mounting. Insert the bar into the lower mount lining the bushing sleeve up with the CENTER set of holes. Insert a 5/8"-18 x 3" bolt into the hole/sleeve. Install a 5/8"-18 nylok jam nut on the bolt threads sticking out of the bracket. Repeat on both sides and tighten the bolts/nuts enough to eliminate any gaps. Skip to **Step 23**.

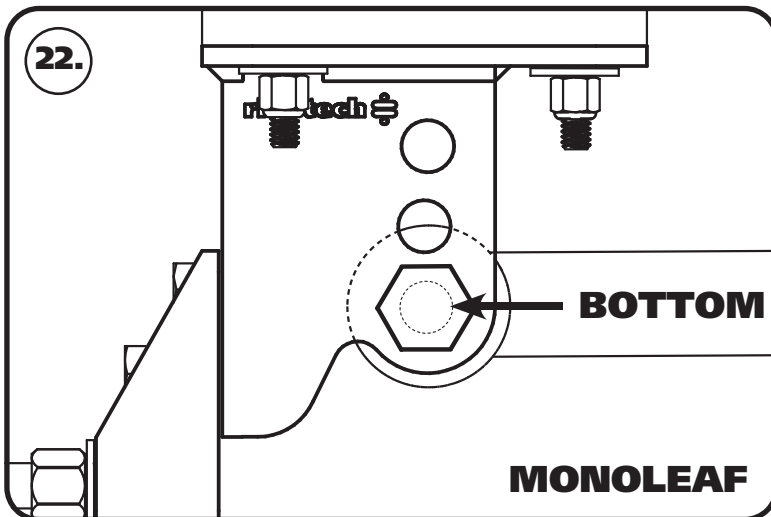

**22. MONOLEAF** - The Monoleaf setup uses the BOTTOM HOLES for mounting. Insert the bar into the lower mount lining the bushing Sleeve up with the BOTTOM set of holes. Insert a 5/8"-18 x 3" bolt into the hole/sleeve. Install a 5/8"-18 nylok jam nut on the bolt threads sticking out of the bracket. Repeat on both sides and tighten the bolts/nuts enough to eliminate any gaps.



**23. Image 23** shows a bottom view of the bar installed. Notice the spacers in each side of the R-Joint.



### Setting Pinion Angle

**READ PAGES 14-16 ON SETTING RIDE HEIGHT, SETTING PINION ANGLES & UPPER BAR TAB JIG INSTALLATION .**

How do you set the pinion angle? On a single-piece shaft you want to set it up where a line drawn through the center of the engine crankshaft or output shaft of the transmission and a line drawn through the center of the pinion are parallel to each other but not the same line.

Your transmission angle should be around 3 degrees down in the rear. If it is more or less than 3 degrees, you might want to consider changing it. Too little angle on the transmission reduces the amount of oil getting to the rear bushing. Too much transmission angle will increase the working angles of the u-joints which will increase the wear. With the transmission at 3 degrees down in the rear, you will want to set the pinion 3 degrees up in the front.

A simple way to do this is to place a digital angle finder or dial level on the front face of the lower engine pulley or harmonic balancer. This will give you a reading that is 90 degrees to the crank or output shaft unless you have real problems with your balancer. At the other end, you can place the same level or angle finder against the front face of the pinion yoke that is also at 90 degrees to the center line. If you rotate the yoke up or down so both angles match, you have perfect alignment.

Road testing will tell you if you have it right. If you accelerate and you get or increase a vibration, then the pinion yoke is too HIGH. Rotate it downward in small increments of a degree or two until the problem goes away. If you get or increase a vibration when decelerating, then the pinion yoke is too LOW. Rotate it upward to correct it.

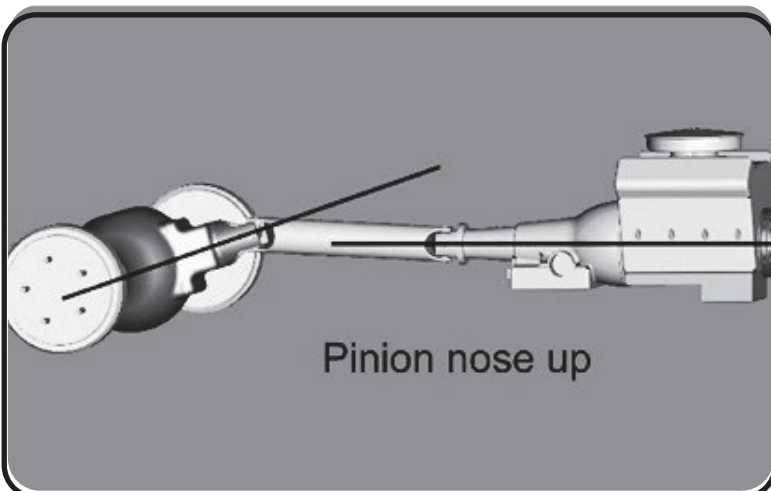
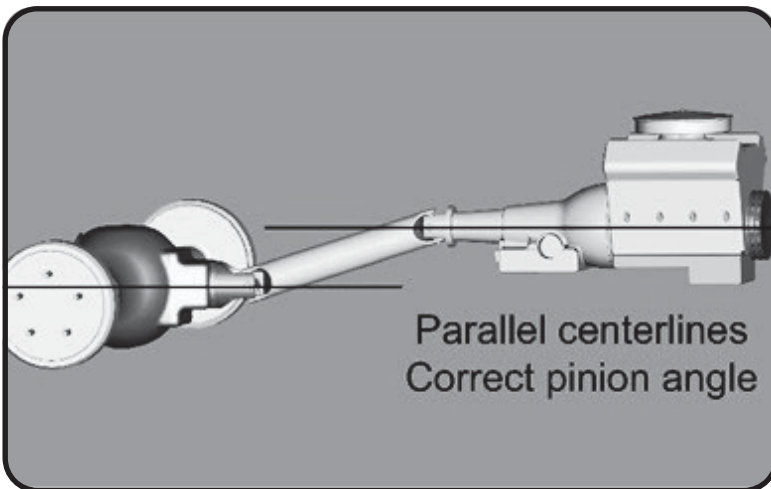
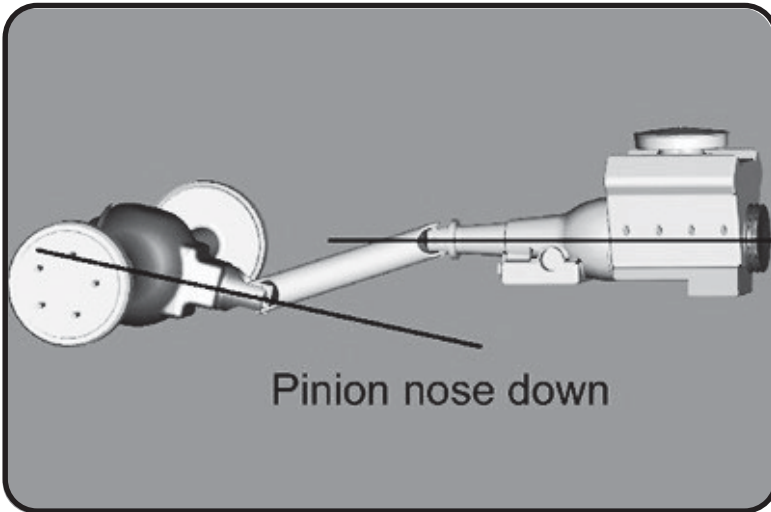



### Upper Bar Tab Installation Jig

#### Upper Bar Installation Jig

- This jig has been supplied to aid in the installation of the upper 4 link bar. It can be temporarily used to properly align, locate and weld the tabs onto the axle. It will also ensure that the mounting bolts are parallel to the ground.
- Follow the diagram below to set the jig to the same length as the upper bar, use the 3/8" x 3/4" bolt and nuts to set the length.
- Position the axle at ride height. Center the axle left to right between the quarter panels. Set pinion angle.
- Bolt one end of the jig to the cradle using a 5/8" x 3" bolt.
- Using another 5/8" x 3" bolt, fasten the axle tabs to the other end. There is a Driver and Passenger Inner Tab. It is bent to keep the tab from hitting the center section of the rear end. It is positioned with the tab bent to the front of the car. The short tab goes to the outside of the car. The tabs must be bolted to the outside of the jig.
- Swing the bar down letting the tabs rest onto the axle. Trim the brackets as necessary to minimize the gap to be welded.
- Check pinion angle, ride height and axle center. Tack-weld the tabs in place and tack-weld the back brace in place. Refer to Images 25 & 26 for position of the back brace.
- Remove jig and install upper bar.
- Repeat this process for the other side.
- Recheck pinion angle, ride height and axle center. (Sound familiar?)
- After the tabs have been tack welded on both sides, remove the upper bars to avoid damaging the rod end. Let the axle drop down for better access to the tabs. Lay 1" welds on the inside and outside of the tabs. Skip around from one side to the other to avoid overheating the tube.

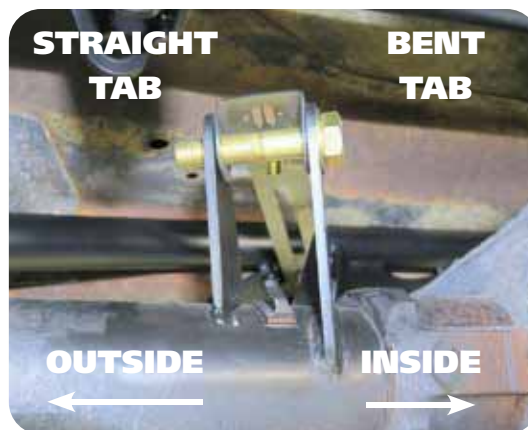
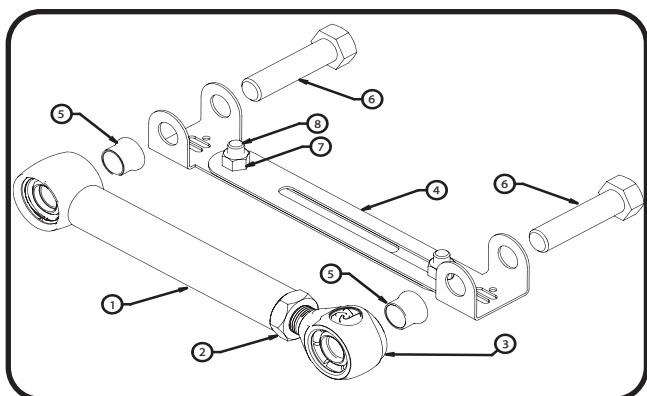

Item#	Description
1	Upper Bar
2	3/4"-16 Jam Nut
3	R-Joint End
4	Alignment Jig
5	Aluminum Spacer
6	5/8" x 2 3/4" Bolt
7	3/8"-16 Nut
8	3/8"-16 x 3/4" Bolt



### Installing Axle Tabs



**24.** One helpful trick to help maintain ride height and pinion angle while adjusting is to tack weld a spacer between the axle and the outside of the frame as shown in the picture. This spacer should be 3 3/4" tall giving the Shockwave an eye-to-eye measurement of approximately 14 1/2". When measuring the axle center you can measure off of the frame rails. We also use a plum bob off the quarter panels to double check the axle center. Refer to **Page 14** on setting the pinion angle.

**Note:** You can tack weld the spacer in place after you get the pinion angle, and axle center set. This will ensure that nothing moves through the upper tab Installation.

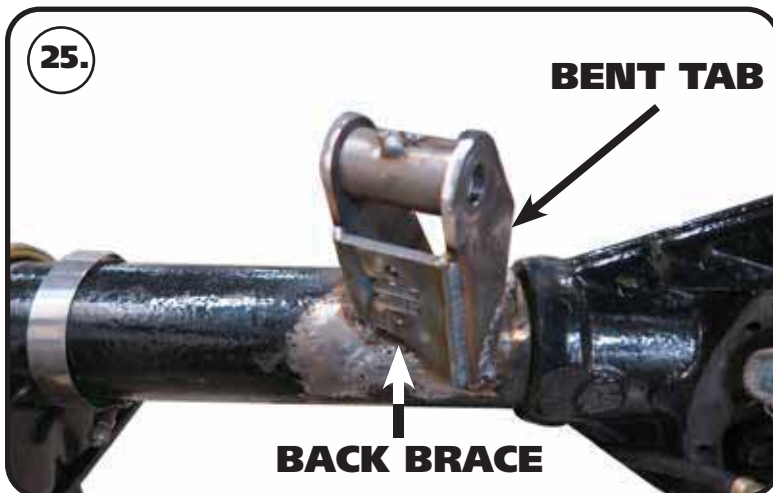

**25.** Check the length of the upper bar; it should be 8.625" center to center. Bolt the axle tabs to the setting jig as specified on the previous page. Straight tab to the outside of the car, bent tab to the inside of the car. The bend needs to be to the front, making the front of the tab run parallel with the cast center section. If they are installed on the incorrect sides, the tab will hit the center section of the axle. Next, place the other end into the cradle. Both ends use a 5/8" x 3" and should not be fully tightened yet. For now just let axle tabs sit on the axle.

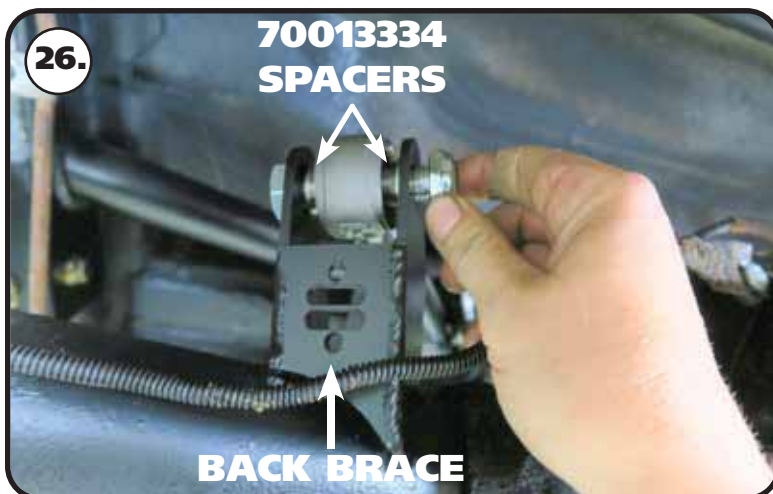

**26.** Check the fitment of the tabs and tack weld them to the axle. Do this for the Driver and Passenger side bars. Insert the bars into the cradle and tabs to double check fitment. Recheck axle center and pinion angle. Once satisfied with fitment weld the upper bar tabs onto the axle. Weld 1" at a time, skip around from one side to the other, and one tab to the other to avoid overheating the axle tube. When the tabs cool down, install the upper bars using (1) 5/8" x 3" bolt, (2) 5/8" flat washers, and (1) 5/8" Thin nylok nut on each end. Install a 70013334 spacer in each side of the R-joint using **Image 26** as a reference. Repeat on both sides and tighten the bolts/nuts enough to eliminate any gaps.



### Installing Shockwaves/Coilovers



#### **Remove the Spacer from between the Axle and Frame.**

**27.** Install a 1/2" ID 90002043 spacer on each side of the upper Coilover/ShockWave. Slide the assembly into the upper crossmember from the bottom side. Position the adjuster knob so that the knob points toward the center of the car. Line up the hole in the spacers with the hole in the upper shock bridge and insert 1/2"-13 x 2 1/4" bolt and install 1/2"-13 Thin Nylok nut.



**28.** Install a 5/8" ID 90002067 spacer (**Small side towards shock body**) onto the lower Shock Stud. Slide the bottom of the Shock onto the Stud. Install a second 5/8" ID 90002067 Spacer onto the Stud (**small side towards shock**). You may need to jack the rearend up to Slide the Shock onto the Stud. Install the 7/16" Flat washer and 7/16" Nylok nut. Tighten the upper and lower shock bolts. Torque the Upper Bolt to 55 ftlbs and the Lower Nut to 40 ftlbs. The designed ride height of the CoilOver/Shockwave is 14 1/2" center to center.

**Note:** If installing Shockwaves and you want to locate the air fitting in a different location, the air spring assembly can be rotated on the shock by grabbing the air spring assembly by hand and spinning it on the shock.



**Part # 11266510**

**1968-1972 GM X-Body (Nova) HQ Rear CoilOvers**

Recommended Tools

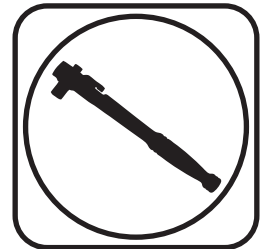

**1968-1972 GM "X"Body HQ Series Rear CoilOvers**

## Installation Instructions

Table of contents

Page 40..... Included Components

Page 41-44.... Assembly and Adjusting

ShockWave Dimensions:

Center of bearing to Center of bearing:

Compressed: 11.23"

Ride Height: 14.50"

Extended: 16.43"





### Major Components .....In the box

Item #	Part #	Description	QTY
1	982-10-805	5.2" Stroke HQ Series Shock	2
2	815-05-022-KIT	1.7" Shock Eyelet	2
3	803-00-109(kit)	Upper CoilSpring Retaining Plate (803-00-109 kit)	
4	59120175	Coilspring 12" 175lb	2
5	70010828	Delrin Spring Washer	4
6	803-00-109(kit)	Lower Spring Adjuster Nut (803-00-109 kit)	2
7	803-00-109(kit)	Adjuster Nut Locking Screw (803-00-109 kit)	2
8	803-00-109(kit)	Retaining Ring (803-00-109 kit)	2
9	90002043	1/2" ID Upper Shock Bearing Spacer Half	4
	90001994	5/8" ID Bearing (installed in shock and eyelet)	4
	90001995	Bearing Snap Ring (installed in shock and eyelet)	8

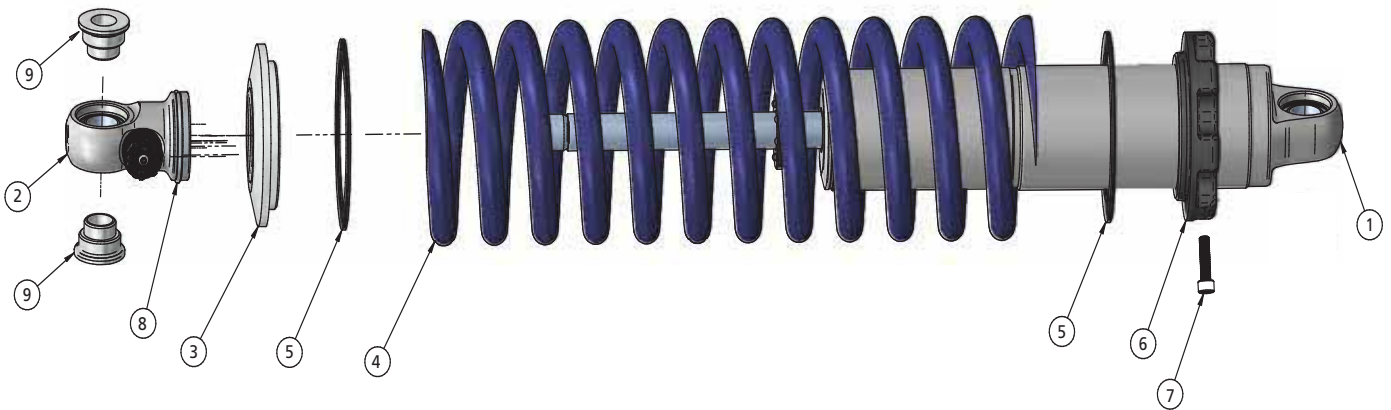



# COILOVER ASSEMBLY INSTRUCTIONS



**1.** Thread the preload adjustment nut onto the shock from the bottom (Figure 1). A few threads of engagement is ok for now.



Figure 1

**2.** The rebound adjustment knob must be removed prior to installing the upper spring mount in step 4. Turn the adjustment knob clockwise until it stops, then remove the torx screw and the knob (Figure 2).



Figure 2

**3.** Slide a Delrin washer over the shock and onto the adjustment nut, followed by the coil spring (Figure 3).



Figure 3

**4.** With the adjustment knob removed, slide a Delrin washer over the eyelet and place on top of the coil spring, followed by the upper spring mount (Figure 4).



Figure 4



# COILOVER ASSEMBLY INSTRUCTIONS



**5.** Slide the retainer clip over the upper eyelet and into the groove at the base of the eyelet. Make sure it snaps into place and is fully seated in the groove (Figure 5).



Figure 5

**6.** Reinstall the adjustment knob (Figure 6).

Once you have reinstalled the knob, you may want to turn the knob about 12 clicks counterclockwise since the rebound is currently set at "full stiff".



Figure 6

**7.** Thread the adjustment nut up the shock body to remove the slack and secure the spring and upper mount against the eyelet. Install the locking screw in the adjustment nut, but do not tighten yet (Figure 7). This screw will be tightened after your preload has been set.



Figure 7

**8.** Your assembled coilover is ready to be installed on the vehicle.



Figure 8



# TUNING GUIDE

## SINGLE-ADJUSTABLE SHOCKS



### The Basics...

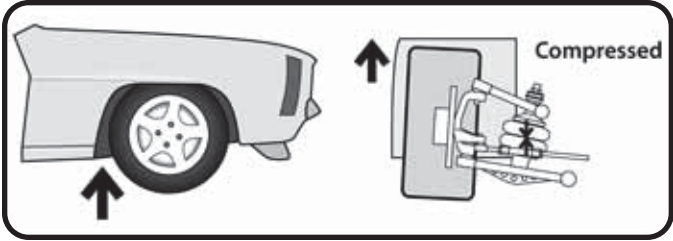

#### COMPRESSION

This typically occurs when you hit a bump in the road. The bump forces the wheel/tire/suspension assembly to "compress" or move upwards into the car.

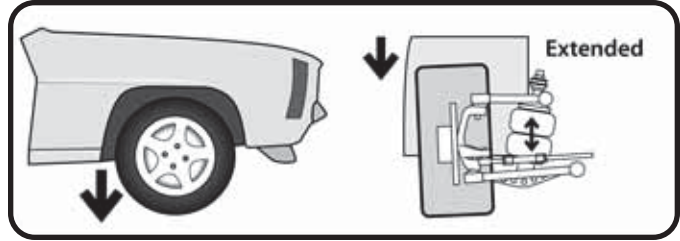

#### REBOUND

Rebound is the opposite of compression. This occurs when the wheel/tire/suspension assembly falls into a pothole, or simply "rebounds" from being compressed.

### Where Are The Knobs?

#### HQ Series Shocks

- The adjustment knob is located on the top of the shock, either protruding from the side of the eyelet, or atop the stud.
- This knob provides rebound adjustment only.

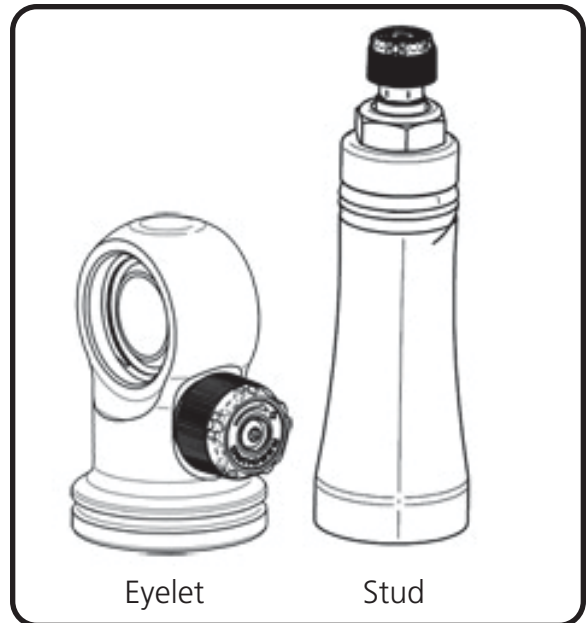

### Knob Function

Counterclockwise

=  
Softer

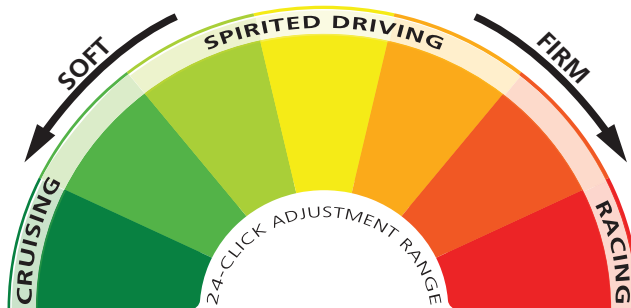

Clockwise

=  
Firmer





# TUNING GUIDE

## SINGLE-ADJUSTABLE SHOCKS



### Initial Rebound Setting

**NOTE:** Before jumping straight to a middle-of-the-road shock setting, we recommend you experience the full range of adjustment potential of your new shocks by first driving your vehicle at both the “full stiff” and “full soft” settings. Understanding how your shocks behave at these extremes will provide recognizable reference points as you attempt to dial in your settings.

1. Begin by setting your shocks to the “full stiff”, or minimal rebound position. You do this by turning the adjustment knob clockwise until it stops.

2. Now turn the adjustment knob counterclockwise 12 clicks. This is the approximate center of the adjustment range.

3. Take the vehicle for a test drive. Try to determine if you are experiencing any of the unwanted behaviors found at the extremes of the adjustment range. If you are satisfied with the ride quality and handling, you’re all set. Enjoy the ride!

4. If the vehicle feels too “floaty” or soft, turn the knob a few clicks clockwise to increase the damping effect.

If the ride quality is still too harsh or stiff, turn the knob a few more clicks counterclockwise to decrease the damping effect.

5. Take the vehicle for another test drive. If necessary, repeat the steps above until your desired optimal ride quality has been achieved.



### General Guidelines

- The rear shocks typically have the most influence on ride quality. This is due to your seating position being closer to the rear than the front.
- Adjustments to the front shocks will generally require 3-4 clicks in any direction to be noticeable, while adjustments to the rear shocks may only require 1-2 clicks to be felt.
- Don’t be afraid to turn the knobs and experience the full adjustment range. You are not going to hurt anything and you can always go back if you adjust too far one way or the other.