

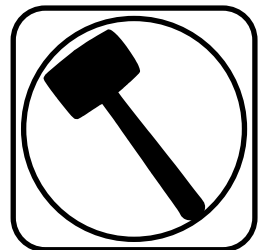

Part # 11281010

1965-1970 Full Size Chevy Car FRONT CoolRide Air Spring Kit with HQ Series Shocks

Recommended Tools



1965-1970 Full Size Chevy CoolRide Air Spring Kit Installation Instructions

Table of contents

- Page 2..... CoolRide Kit Components & Hardware List
- Page 3..... Getting Started
- Page 3-4..... Installing CoolRide
- Page 5..... Installing Shock
- Page 6-7..... Shock Adjustment

THIS COOLRIDE KIT IS DESIGNED TO BE USED WITH OEM CONTROL ARMS.

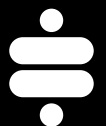



CoolRide Kit ComponentsIn the box

Item #	Part Number	Description	QTY
1	90000052	Upper Air Spring Cup Bracket	2
2	90006781	6.5" Diameter Air Spring	2
3	90000408	Lower Air Spring Plate - Driver - Shown	1
3	90000409	Lower Air Spring Plate - Passenger	1
4	986-10-036	4.75" Eyelet Top HQ Series Shock	2
5	90000011	Upper shock Bracket	2
6	70011138	3/4" ID Shock Bushing	4
7	90002102	1/2" ID x 1.312" Shock Sleeve	2
8	90002103	5/8" ID x 1.312" Shock Sleeve	2
9a	90001617 kit	Shock Stud - 70002825	2
9b	90001617 kit	5/8" SAE Flat Washer - 99623004	6
9c	90001617 kit	7/16" SAE Flat Washer - 99433002	2
9d	90001617 kit	5/8"-18 Lock Nut - 99622003	2
9e	90001617 kit	7/16"-14 Nylok Nut - 99432002	2

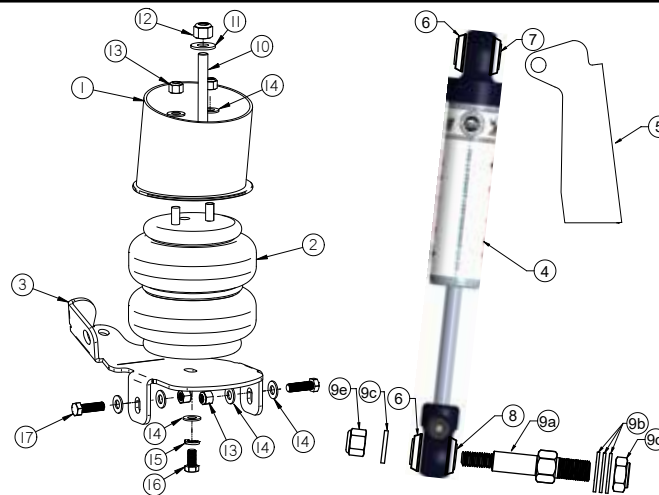

CoolRide HardwareIn the box

Item#	Part Number	Description	QTY	Item #	Part Number	Description	QTY
UPPER AIR SPRING MOUNTING				LOWER AIR SPRING MOUNTING			
10	99435002	7/16"-14 x 8" Stud	2	16	99371001	3/8"-16 X 3/4" Bolt	2
11	99433002	7/16" Flat Washer	2	LOWER AIR SPRING PLATE			
12	99432001	7/16"-14 Nylok Nut	2	13	99372002	3/8"-16 Nylok Nut	4
13	99372002	3/8"-16 Nylok Nut	4	14	99373003	SAE Flat Washer	8
14	99373003	3/8" SAE Flat Washer	4	17	99371004	3/8"-16 X 1 1/4" Hex Bolt	4
LOWER AIR SPRING MOUNTING				UPPER SHOCK MOUNTING			
14	99373003	3/8" SAE Flat Washer	2		99501003	1/2"-13 X 2 1/2" Hex Bolt	2
15	99373005	3/8" Split Lock Washer	2		99502001	1/2"-13 Nylok Nut	2



Getting Started.....

THIS KIT IS DESIGNED TO BE USED WITH OEM CONTROL ARMS.

1. Raise and support car at a safe, comfortable working height. Let the front suspension hang freely
2. Remove coil spring and shock absorber. Refer to factory service manual for proper disassembly procedure.
3. Apply thread sealant to the air fitting and screw it into the top of the air spring.

Installing CoolRide



4. Assemble the upper cup bracket to the air spring, using 3/8"-16 Nylok nuts and 3/8" flat washers. Torque the 3/8" nuts 15-20 ftlbs.



5. Thread the 8" stud into the nut in the bottom of the cup.



Installing CoolRide



6. Place the lower air spring plate onto the lower control arm as shown in the picture. This is the Drivers side with the shock mount to the rear of the control arm. The plate will index off the rear strut arm bolt. The other two holes must be drilled for 3/8" x 1 1/4" bolts. Install flat washers and nylok nuts. Torque to 30 ft-lbs



7. The coil spring pocket will need to be trimmed for air spring clearance as shown in the picture. Install the air spring assembly into the coil spring pocket with the all thread protruding through the factory shock hole. The fitting access hole (tall side of bracket) will be clocked towards the outer tie rod end. Fasten with 7/16" Nylok and flat washer. The airline must be routed at this time. Torque 25-35 ft-lbs.



8. Secure the air spring to the lower plate use a 3/8" x 3/4" bolt, lock washer, and flat washer. Torque the 3/8" nuts 15-20 ftlbs.

9. Reattach the tie rod, spindle, and sway bar. Refer to a factory service manual for proper assemble procedure. The sway bar end link may be shortened to achieve proper clearance. This can be done by shortening the end link and bolt.

11. Double check the air spring clearance through full suspension travel. This air spring should be approximately 5" tall at ride height. This should be around 100psi.

IT IS THE FINAL RESPONSIBILITY OF THE INSTALLER TO MAKE SURE THE AIR SPRING DOES NOT RUB ON ANYTHING AT ANYTIME!!!



Installation



1. The upper shock mount must be welded to the frame. It may need to be cut down to match the stroke of the air spring and suspension. Make sure that when the suspension is fully compressed the shock is about $\frac{1}{4}$ " from being fully compressed. Just tack weld the mount for now and install the lower shock stud and shock. The upper mount will use a $2\frac{1}{2}$ " x $\frac{1}{2}$ " bolt and nyloc. Check to make sure the shock does not bottom out when the suspension is fully compressed. If the shock bottoms out it could damage the shock or shock mounts.



2. Install a shock stud in the provision of the lower air spring mount. Use **Images 2a & 2b** as a guide for assembling the shock stud/shock.

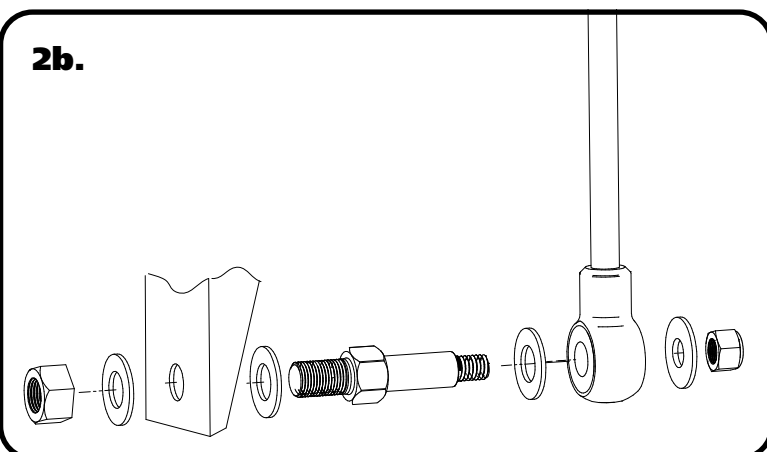

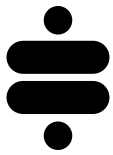

TUNING GUIDE

SINGLE-ADJUSTABLE SHOCKS

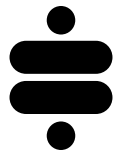

The Basics...

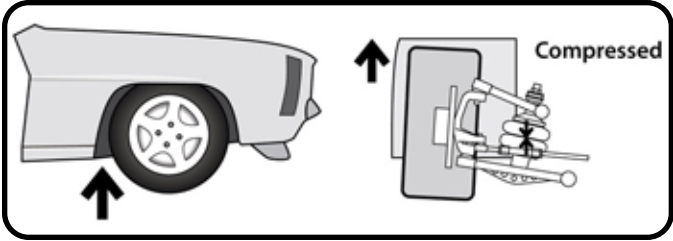

COMPRESSION

This typically occurs when you hit a bump in the road. The bump forces the wheel/tire/suspension assembly to "compress" or move upwards into the car.

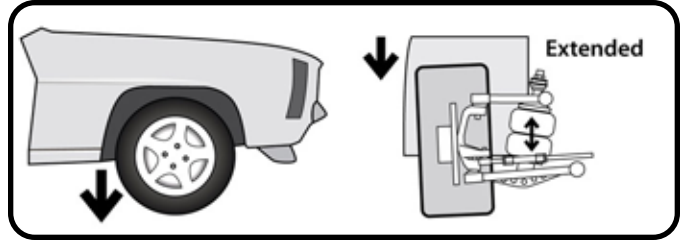

REBOUND

Rebound is the opposite of compression. This occurs when the wheel/tire/suspension assembly falls into a pothole, or simply "rebounds" from being compressed.

Where Are The Knobs?

HQ Series Shocks

- The adjustment knob is located on the top of the shock, either protruding from the side of the eyelet, or atop the stud.
- This knob provides rebound adjustment only.

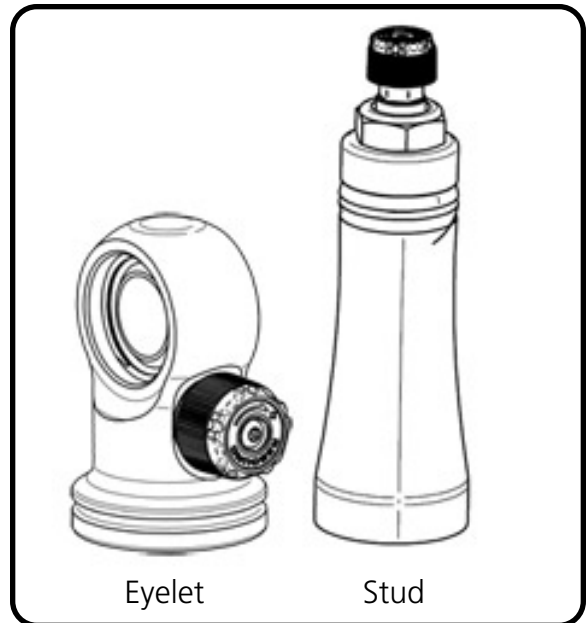

Knob Function

Counterclockwise

=
Softer

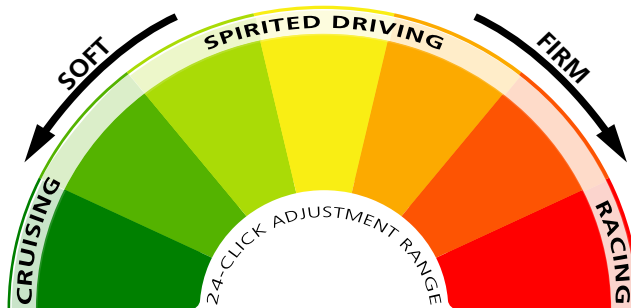

Clockwise

=
Firmer



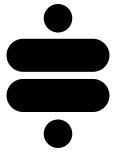

TUNING GUIDE

SINGLE-ADJUSTABLE SHOCKS

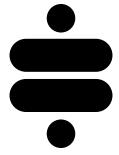

Initial Rebound Setting

NOTE: Before jumping straight to a middle-of-the-road shock setting, we recommend you experience the full range of adjustment potential of your new shocks by first driving your vehicle at both the “full stiff” and “full soft” settings. Understanding how your shocks behave at these extremes will provide recognizable reference points as you attempt to dial in your settings.

1. Begin by setting your shocks to the “full stiff”, or minimal rebound position. You do this by turning the adjustment knob clockwise until it stops.



2. Now turn the adjustment knob counterclockwise 12 clicks. This is the approximate center of the adjustment range.



3. Take the vehicle for a test drive. Try to determine if you are experiencing any of the unwanted behaviors found at the extremes of the adjustment range. If you are satisfied with the ride quality and handling, you’re all set. Enjoy the ride!



4. If the vehicle feels too “floaty” or soft, turn the knob a few clicks clockwise to increase the damping effect.



If the ride quality is still too harsh or stiff, turn the knob a few more clicks counterclockwise to decrease the damping effect.



5. Take the vehicle for another test drive. If necessary, repeat the steps above until your desired optimal ride quality has been achieved.



General Guidelines

- The rear shocks typically have the most influence on ride quality. This is due to your seating position being closer to the rear than the front.
- Adjustments to the front shocks will generally require 3-4 clicks in any direction to be noticeable, while adjustments to the rear shocks may only require 1-2 clicks to be felt.
- Don’t be afraid to turn the knobs and experience the full adjustment range. You are not going to hurt anything and you can always go back if you adjust too far one way or the other.