



Part # 11284010

1965-1970 Full Size Chevy Car REAR CoolRide Air Spring Kit with HQ Series Shocks



Recommended Tools

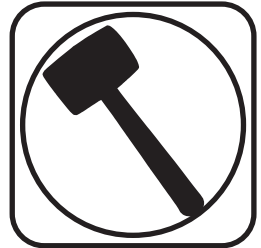
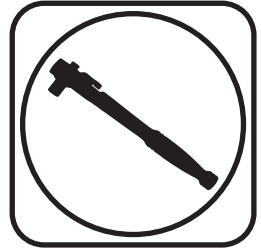

1965-1970 Full Size Chevy CoolRide Air Spring Kit Installation Instructions

Table of contents

- Page 2..... CoolRide Kit Components
- Page 3..... Hardware List & Getting Started
- Page 4-6..... Installing CoolRide
- Page 6..... Shock Adjustment

THIS COOLRIDE KIT IS DESIGNED TO BE USED WITH OEM CONTROL ARMS.



CoolRide Kit ComponentsIn the box

Item #	Part Number	Description	QTY
1	90000024	Upper Air Spring Cup Bracket	2
2	90006781	6.5" Diameter AirSpring	2
3	90000070	Lower Air Spring Roll Plate	2
4	90000224	Large Upper Washer - may not be needed	2
5	986-10-020	7.55" HQ Series Shock Assembly	2
6	90001619	Cantilever PIN Bolt Kit	2
7	70011139	5/8" ID Shock Bushing	2
8	90002068	Extended Trunnion	2
9	70011138	3/4" ID Shock Bushing	2
10	90002102	1/2" ID x 1.312" Shock Sleeve	2

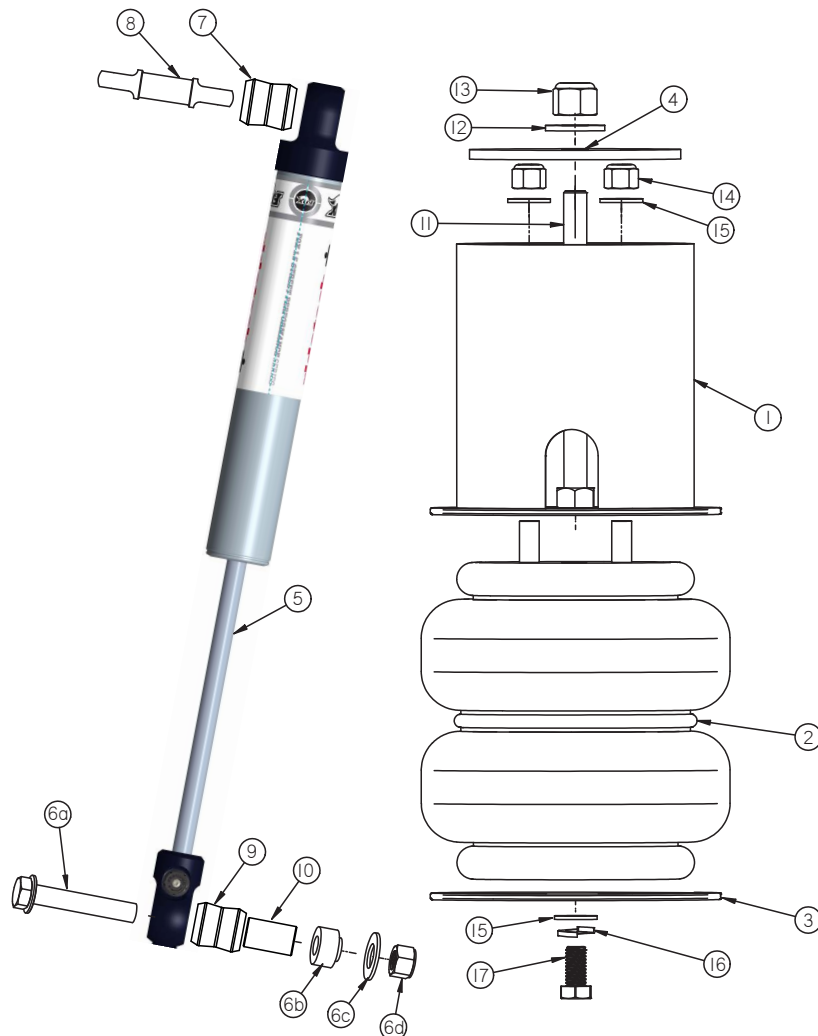



CoolRide Hardware Kits.....In the box

Kit # 99010120

Item #	Part Number	Description	QTY
UPPER AIR SPRING MOUNTING			
11	99435001	7/16"-14 x 6" Stud	2
12	99432001	7/16"-14 Nylok Nut	2
13	99433002	7/16" Flat Washer	2
14	99372002	3/8"-16 Nylok Nut	4
15	99373003	SAE Flat Washer	4
LOWER AIR SPRING MOUNTING			
15	99373003	3/8" SAE Flat Washer	2
16	99373005	3/8" Split Lock Washer	2
17	99371001	3/8"-16 X 3/4" Hex Bolt	2

Kit # 99010119

Item #	Part Number	Description	QTY
SHOCK HARDWARE			
	99311001	5/16"-18 X 1" Hex Bolt	4
	99312003	5/16"-18 Nylok Nut	4
	99313002	5/16" SAE Flat Washer	8

Getting Started.....

THIS COOLRIDE KIT IS DESIGNED TO BE USED WITH OEM CONTROL ARMS.

1. Raise and support vehicle at a safe and comfortable working height.
2. Support axle then remove coil spring, and shock. Refer to service manual for proper disassembly procedure.
3. Apply thread sealant to the air fitting and screw it into the air spring.

Installing CoolRide



4. Apply thread sealant to the air fitting and screw it into the air spring. Assemble the upper cup bracket to the air spring, using 3/8"-16 Nylok nuts and 3/8" flat washers. Torque the 3/8" nuts 15-20 ftlbs.



Installing CoolRide

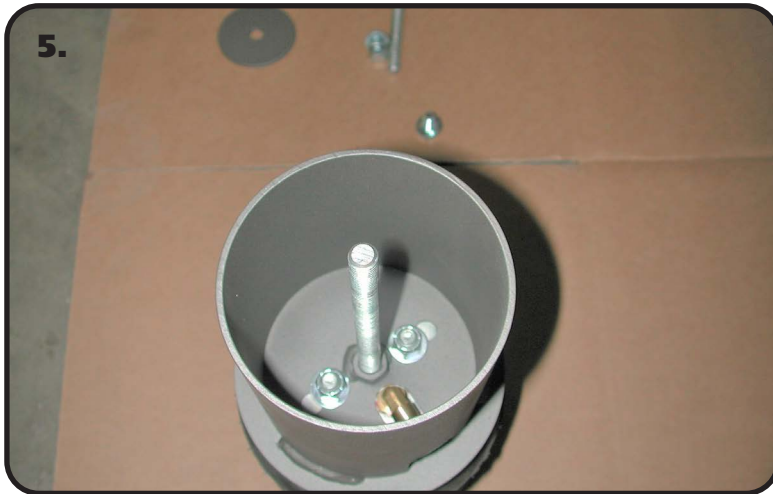

5. Thread the 6" stud into the nut in the bottom of the cup.



6a & 6b The large washer needs to be installed on the TOP side of the frame at the coil spring pocket.



6b. The washer needs to be center on the upper opening.



Installing CoolRide



7. Place the air spring assembly into the coil spring pocket with the tab on the side of the cup aligning with the factory bump stop mount. The stud should poke through the hole in the upper coil spring pocket. Some cars may not have this hole and it must be drilled with a 7/16" drill bit. Fasten with a 7/16" Nylok nut and flat washer. Torque 25-35 ft-lbs.



8. Slide the lower plate between the air spring and the lower arm. It is held tight with a 3/8" x 3/4" bolt with flat washer and lock washer. Torque the 3/8" bolt to 15-20 ftlbs.

Install the Ridetech HQ Series Shock kit #11280701.

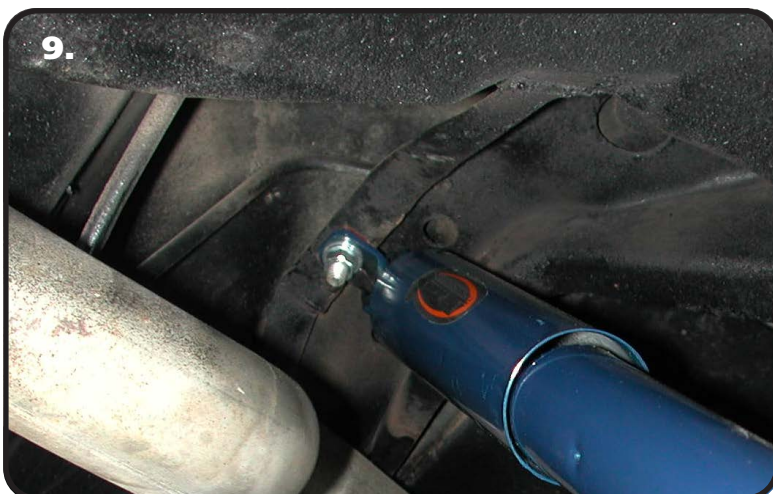

9. Attach shock T-Bar to frame using 5/16" x 1" bolts, Nylok nuts and flat washers. Torque to 17 ft-lbs.



Installing CoolRide

10.

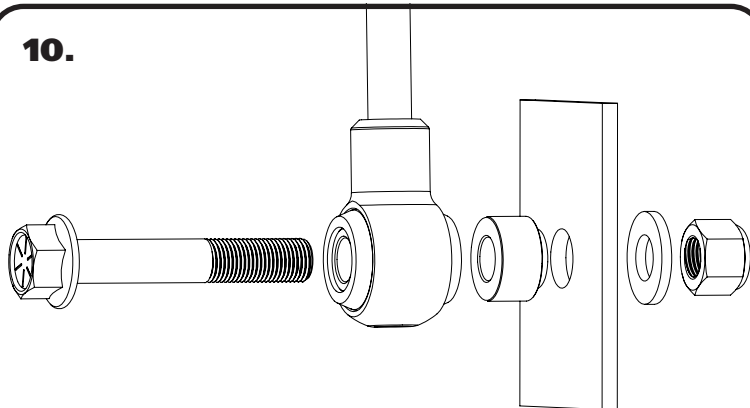

10. Attach the shock to the axle using the new shock bolt kit supplied. Use **Diagram 10** as a reference for assembly. Torque to 75 ft-lbs.

11. This air spring should be approximately 5" tall at ride height.

IT IS THE FINAL RESPONSIBILITY OF THE CUSTOMER TO ENSURE THAT THE AIR SPRING DOES NOT RUB ON ANYTHING AT ANYTIME!!

Shock Adjustment

Shock adjustment 101- Single Adjustable

Rebound Adjustment:

How to adjust your new shocks

The rebound adjustment knob is located on the top of the shock absorber protruding from the eyelet or stud top. You must first begin at the ZERO setting, then set the shock to a street setting of 12 or handling setting of 8.

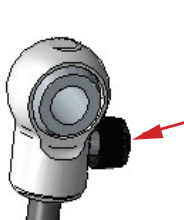

-Begin with the shocks adjusted to the ZERO rebound position (full stiff). Do this by rotating the rebound adjuster knob clockwise until it stops.



-Now turn the rebound adjuster knob counter clockwise 12 clicks. This sets the shock at 12 for a street setting. If you are after a handling setting only go 8 clicks.

Take the vehicle for a test drive.



-if you are satisfied with the ride quality, do not do anything, you are set!

-if the vehicle is too soft increase the damping effect by rotating the rebound knob clockwise 3 additional clicks.



-If the vehicle is too stiff rotate the rebound adjustment knob counter clock wise 2 clicks and you are set!

Take the vehicle for another test drive and repeat the above steps until the ride quality is satisfactory.

Note:

One end of the vehicle will likely reach the desired setting before the other end. If this happens stop adjusting the satisfied end and keep adjusting the unsatisfied end until the overall ride quality is satisfactory.