



Part # 11290202 - 1965-1966 GM "B" Body CoilOver System

Recommended Tools

Front Components:

11282899	Front Lower StrongArms
11283699	Front Upper StrongArms
11283510	Front CoilOver Instructions
11289100	Front SwayBar Instructions

Rear Components:

11286210	Rear CoilOver Kit Includes: Rear Lower StrongArms Rear CoilOvers
11296698	Rear Upper StrongArms
11289000	Adjustable Panhard Bar

Miscellaneous Components:

85000000	Spanner Wrench
----------	----------------

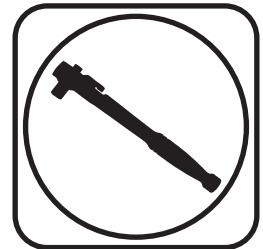

1965-1966 GM "B" Body CoilOver Installation Instructions

Table of contents

Pages 2-6.....	Front CoilOvers
Pages 7-10.....	Front SwayBar
Pages 11-19.....	Front StrongArms
Pages 20-38.....	Rear CoilOver Kit
Pages 39-43.....	Rear SwayBar

THE FRONT CONTROL ARMS ARE DESIGNED TO BE USED WITH THE OEM SPINDLES.

Some vehicles have two factory upper arms and need a second tubular arm, Kit # 11296698.





Part # 11283510 - 1965-1970 GM "B" Body HQ Front CoilOvers

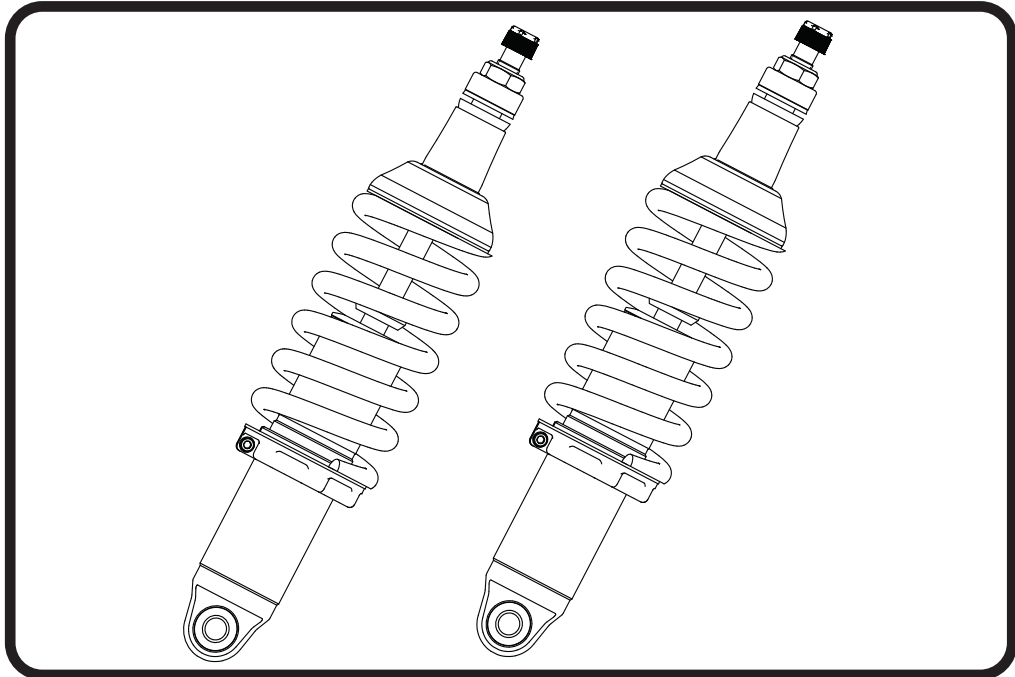

Recommended Tools

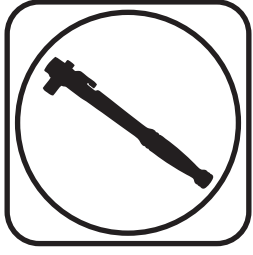

1965-1970 GM "B" Body HQ Series Front CoilOvers

Installation Instructions

Table of contents

Page 3..... Included Components

Page 4..... CoilOver Assembly

Page 5-6..... CoilOver Installation

ShockWave Dimensions:

Center of Bearing to Stud Mounting Surface:	
Compressed:	10.48"
Ride Height:	12.55"
Extended:	14.08"



Major ComponentsIn the box

Item #	Part #	Description	QTY
1	982-10-803	3.6" Stroke HQ Series Shock	2
2	59080750	CoilSpring 8" 750lb	2
3	70010828	Delrin Spring Washer	4
4	803-00-199(kit)	Lower Spring Adjuster Nut (803-00-199 kit)	2
5	803-00-199(kit)	Adjuster Nut Locking Screw (803-00-199 kit)	2
6	90002070	Dropped Upper CoilSpring Retaining Plate	2
7	803-00-199(kit)	CoilSpring Plate Retaining Ring (803-00-199 kit)	2
8	90009989(kit)	2.75" Stud Adjuster Assembly	2
9	90002313	2.75" Stud Top Base	2
10	90001904	Delrin Ball Lower Half	2
11	90001903	Delrin Ball Top Half	2
12	90001902	Delrin Ball Upper Cap	2
13	99562003	9/16-18" Nylok Nut	2
14	210-35-120-0	Shock Adjuster Knob	2
15	90009969	Adjuster Knob Retaining Screw	2
	90001994	5/8" ID Bearing (installed in shock body)	2
	90001995	Bearing Snap Ring (installed in shock body)	4

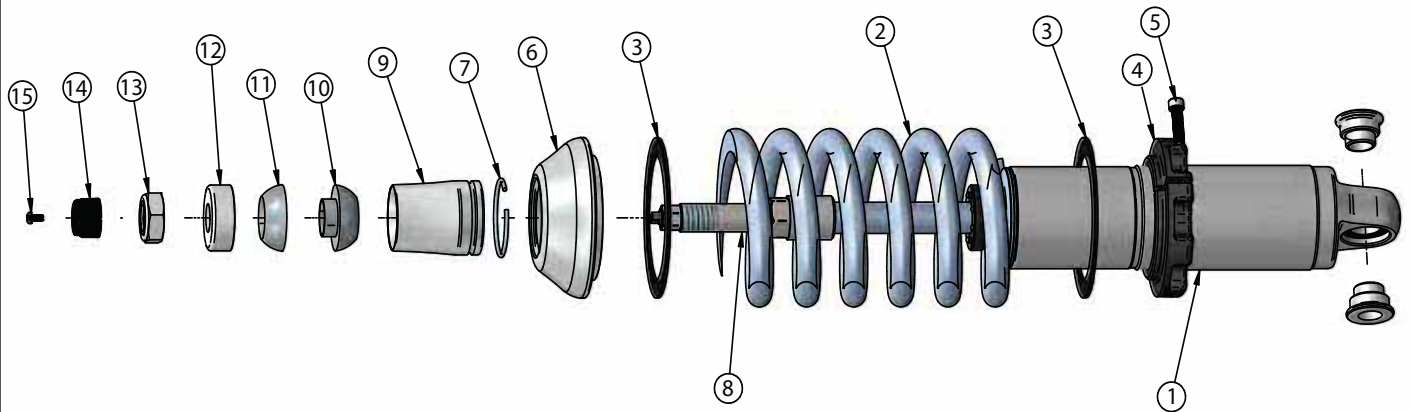



CoilOver Assembly

1.

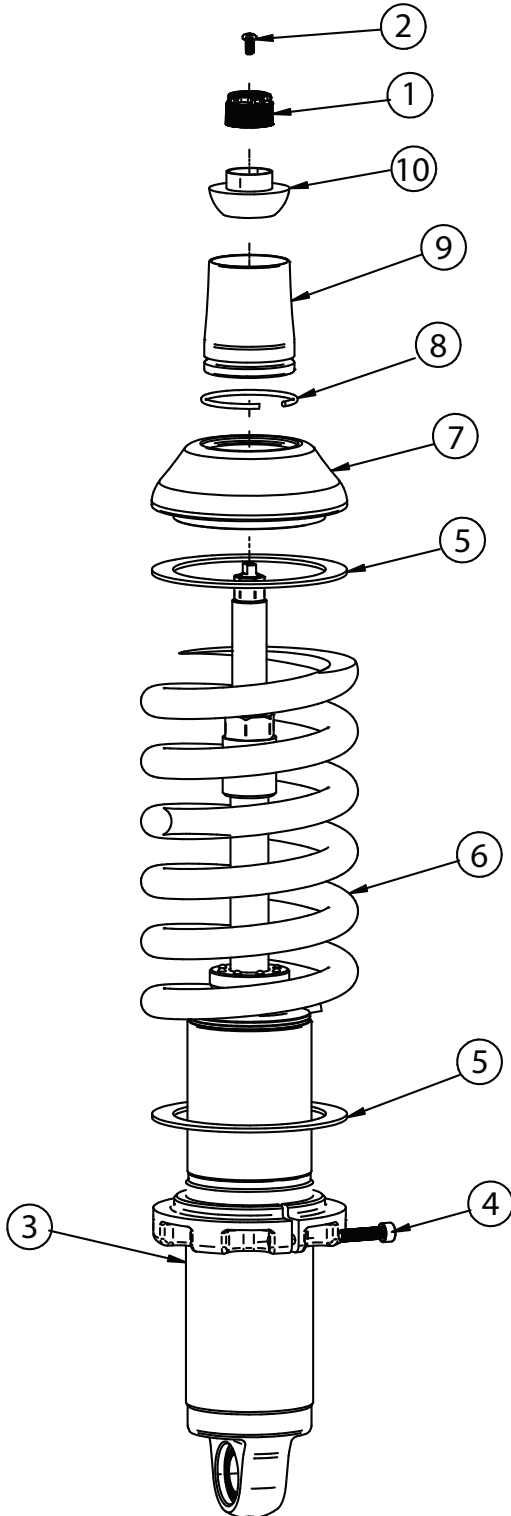

1. To Assemble the CoilOver you need to:
 - a. Remove Screw (2) from center of Adjustment Knob (1) and remove Adjustment Knob.
 - b. Remove Nylok Nut, Delrin Upper Cap, Delrin Upper and Lower Balls, along with the base from the CoilOver stud.
 - c. Thread Adjuster Nut (3) onto the CoilOver body. Once it is threaded on the shock body, lightly thread in the locking screw (4) into the Adjuster Nut.
 - d. Install a Delrin Spring Washer (5) onto the Adjuster Nut.
 - e. Slide the CoilSpring (6) onto the CoilOver.
 - f. Install another Delrin Spring Washer (5) on top of the CoilSpring.
 - g. Install the Upper CoilSpring Plate (7) onto the CoilSpring.
 - h. Install the CoilSpring Retaining Ring (8) onto the Stud Top Base (9). It fits into the groove in the base.
 - i. Slide the Stud Top Base onto the shock until it bottoms out on the stud. It may be necessary to thread the Adjuster Nut down the shock body (to lower the spring) if the base will not slide all the way down onto the stud.
 - k. Slide the Lower Delrin Ball (10) (it has the collar sticking up around the center hole) on to the Stud Top.

Repeat on second CoilOver.



CoilOver Installation



1. Drill the OEM shock hole out to 3/4". This can be done with a Unibit.



2. The CoilOver stud top will come in contact with the coil spring retainer, so it must be opened up towards the engine. **Image 2** has a white line illustrating where to cut the opening for stud top clearance. A die grinder works well here.



3. **Image 3** shows the spring retainer trimmed out.

Note: It may be helpful to go ahead and install the lower StrongArms and CoilOvers to check if any more trimming is necessary.



CoilOver Installation

2.

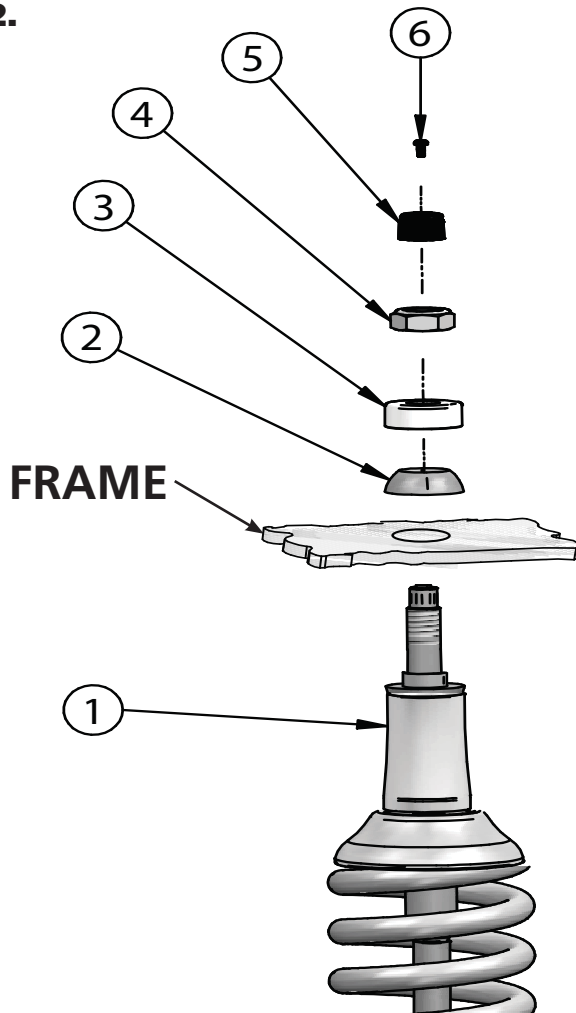

2. With the CoilOver(1) assembled, it is time to bolt them into the car. **The factory shock hole will need to be drilled out to 3/4", this can best be done using a Unibit.** Insert to CoilOver Stud Top through the factory hole in the frame. Install the Upper Delrin Ball(2) onto the shock stud with the flat side facing the frame. Next, Install the Delrin Ball cap (3) onto the shock stud with the Concave side facing the Upper Delrin ball. Install the Nylok Nut(3) onto the shock stud and lightly tighten. The needs to be some resistance on the ball but not tight enough that it will not rotate freely. Reinstall the adjuster knob(5) using the screw (6) that was removed during step 1.

TIGHTENING THE TOP 9/16"-18 NUT: SNUG THE NUT DOWN AGAINST THE TOP CAP. YOU NEED TO BE ABLE TO ARTICULATE THE SHOCK BY HAND. WE TORQUE THE NUT TO 80 INLBS USING A 7/8" CROWS FOOT WRENCH ON A TORQUE WRENCH.

3.

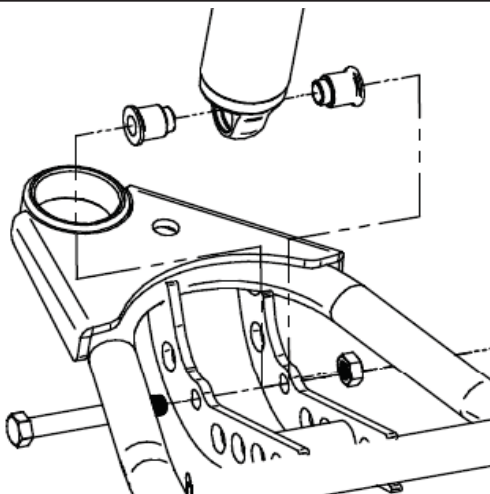

3. Install a spacer on each side of the lower Coilover. Slide the shock with the spacers installed into the lower control arm. Raise the arm up to line up the holes in the bushing with the 1/2" hole in the control arm straps and hold it in place while you install the 1/2" x 3 1/2" bolt, 1/2" flat washer, and 1/2" Nylok nut. Tighten the upper and lower shock bolts.



Part # 11289100 - 1965-1970 B-Body Front Sway Bar



Recommended Tools



1965-1970 GM B-Body Front Sway Bar Installation Instructions

Table of contents
Page 8..... Included Components and Hardware List
Page 9-10..... Sway Bar Installation

Install this Sway bar **BEFORE** installing the lower control arms.



Major ComponentsIn the box

Part #	Description	QTY
90000104	Front Sway Bar	1
90001100	Bushing & Strap Kit	1
90000929	12mm End Link	2
90001092	Tube of Lithium Grease	1

Hardware Kit99010042

Part #	Description	Usage	QTY
99371004	3/8" -16 x 1 1/4" Hex Bolt	Bushing Mount to Frame	4
99373003	3/8" Flat washer	Bushing Mount to Frame	8
99372002	3/8" -16 Nylok Nut	Bushing Mount to Frame	4
99123001	M12 Lock Washer	PosiLink to Sway Bar	2
99122001	M12-1.75 Nylok Nut	PosiLink to Control Arm	2
99433002	7/16" Flat Washer	PosiLink to Control Arm	4

Getting Started.....

Install this Sway bar **BEFORE** installing the lower control arms. It is very difficult to install with the Ridetech lower control arms installed.

This sway bar is designed to be used with Ridetech StrongArms and will NOT fit the OEM control arms.

The sway bar will need to be put in position before installing the bushings and straps



1. Slide the sway bar through the same holes in the frame that the factory bar went through. The sway bar needs to be installed with the center dropping down toward the ground to clear the engine.



Sway Bar Installation



2. Lubricate the sway bar busing with the lithium grease supplied. Install the new polyurethane bushing and strap over the sway bar.



3. Clamp the sway bar up to the frame using a couple "C" clamps. The sway bar should be centered in the hole through the frame.



4. The factory bolt holes may not line up with the new strap. If not, two new holes must be drilled with a 3/8" bit. Secure the assembly with two 3/8" x 1 1/4" bolts, flat washers and Nylok nuts.



Sway Bar Installation



Install the lower StrongArms.

5. Screw one end of the PosiLink into the end of the sway bar. A 12mm lock washer will be used between the stud and the sway bar.



6. The other end of the PosiLink will attach to the tab on the StrongArm using a flat washer on each side of the tab and M12-1.75 nylok nut.

8. Tighten all hardware. 3/8" hardware gets torqued to 30 ft-lbs. M12 gets hardware gets torqued to 65 ft-lbs.

8. Check sway bar clearance through full suspension travel.



Part # 11282899

1965-1970 GM B-Body Front Lower StrongArms



Recommended Tools



1965-1970 GM B-Body Lower StrongArms Installation Instructions

Table of contents	
Page 12.....	Lower Control Arm Components
Page 13.....	Getting Started & Installation
Page 14-15.....	Control Arm Installation

Note: This kit is designed for use with our MuscleBar sway bar. It is easier to install it **before** the lower arms. The factory sway bar will not fit.



Lower Control Arm ComponentsIn the box

Item #	Part Number	Description	QTY
1	90000093	Driver Lower Control Arm (Shown)	1
1	90000094	Passenger Lower Control Arm	1
2	90002586	Lower Ball Joint Assembly - only available through Ridetech	2
3	90000928	Control Arm Bushing	2
4	90000732	Bearing Stud	2
5	90000734	Bearing Housing	2
6	90000735	Bearing Retaining Plate	2
7	90001045	Control Arm Pivot Bearing	2
8	90000733	Pivot Bearing Spacer	2
9	99752006	3/4" -16 Jam Nut	2
10	90002062	ShockWave/CoilOver Bearing Spacers	4
11	99372004	3/8" -16 Hex Nut	2
12	99371004	3/8" -16 x 1 1/4" Hex Bolt	2
13	99501005	1/2" -13 x 3 1/2" Hex Bolt	2
14	99502009	1/2" -13 Nylok Nut	2
	99503014	1/2" SAE Flat Washer	4
15	99371018	3/8" -16 x 1 1/4" SHCS	6
16	99373006	3/8" Split Lock Washer	6
17	99752001	3/4" -16 Lock Nut	2
18	99753002	3/4" Flat Washer	2

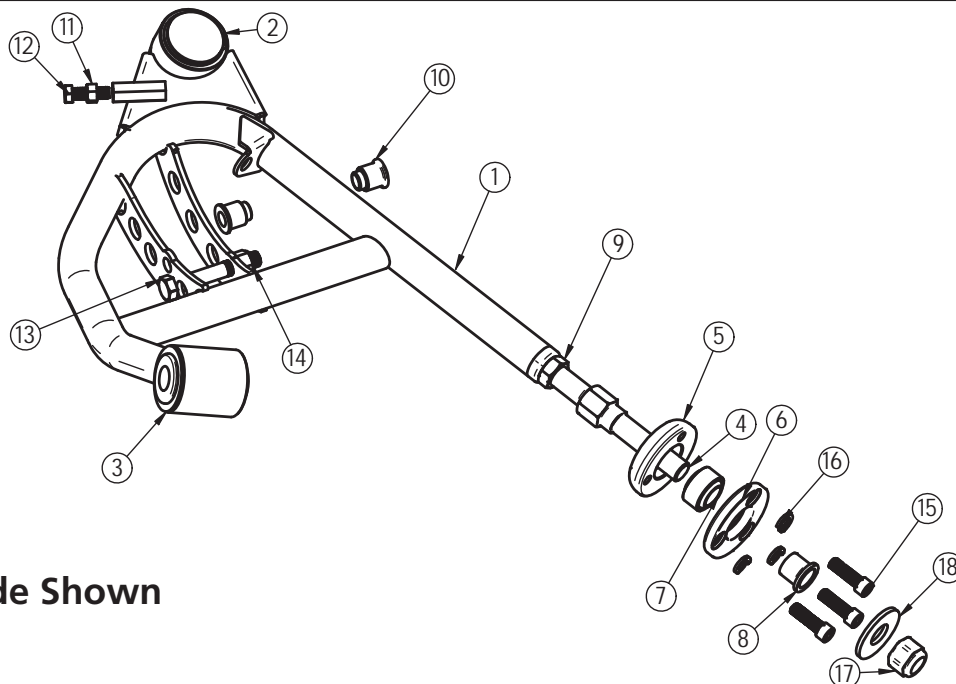

Driver Side Shown



Getting Started.....

Congratulations on your purchase of the Ridetech B-Body StrongArms. These StrongArms have been designed to give your B-Body excellent handling along with a lifetime of enjoyment. Some of the key features of the StrongArms: Ball Joint angles have been optimized for the lowered ride height. The Geometry has been optimized for excellent handling, and drive ability. The control arm is a 1-piece control arm to eliminate the strut rod and bushing.

Note: These control arms are designed for use with the Ridetech ShockWaves or CoilOvers and the MuscleBar swaybar. **The factory shocks and springs or the factory sway bar will not fit these arms.**

Installation

1. Raise and support vehicle at a safe, comfortable working height. Let the front suspension hang freely.
2. Remove the coil spring, shock absorber, upper and lower control arms, sway bar and the strut rods. **The factory lower control arm bolt will be reused.**

Note: This kit is designed for use with our MuscleBar sway bar. It is easier to install it **before** the lower arms. The factory sway bar will not fit.

3. Drill the factory upper shock mounting hole to 3/4". This can be done easily with a Unibit.

Attach the CoilOver/ShockWave to the frame before installing the lower control arm.

Suggested Alignment Specs:

Camber: Street: -.5 degrees
Caster: Street: +3.0 to + 5.0 degrees
Toe: Street: 1/16" to 1/8" toe in

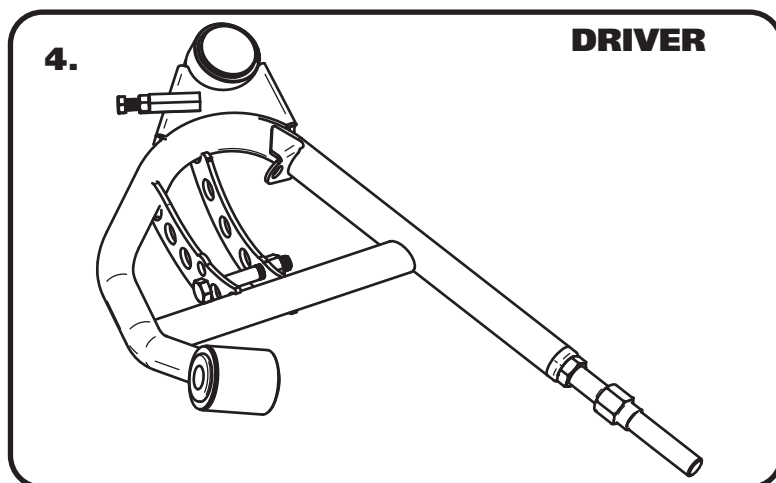

4. The control arms are marked "D" for Driver and "P" for Passenger. The ball joint pin points down and the sway bar mount is on the front side of the arm.



Control Arm Installation



5. Using the bearing retainer as a template; drill three 3/8" holes in the frame to secure the assembly. Use three 3/8" x 1 1/4" SHCS and lock washers to secure the assembly. Torque to 30 ft-lbs.

Note: The hole in the frame may need to be buffed to allow bearing assembly to slide in.



6. Insert the front leg of the control arm into the frame swivel bearing. Bolt the lower StrongArm to the frame using the factory bolt. **The lower control arm pivot bolt gets torqued to 100-125 ft-lbs when the car is sitting on the ground.**

7.

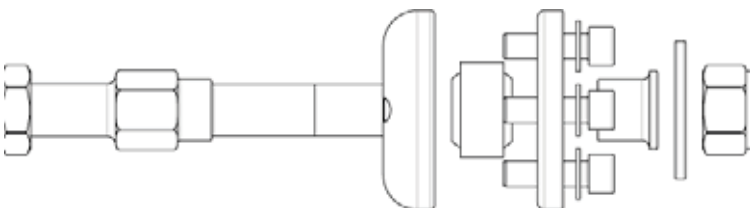

7. The front leg of the lower arm will attach to the frame in place of the strut rod. Refer to **Diagram 7** for assembly order. Torque the 3/4"-16 nut to 75 ft-lbs.



Control Arm Installation

8.

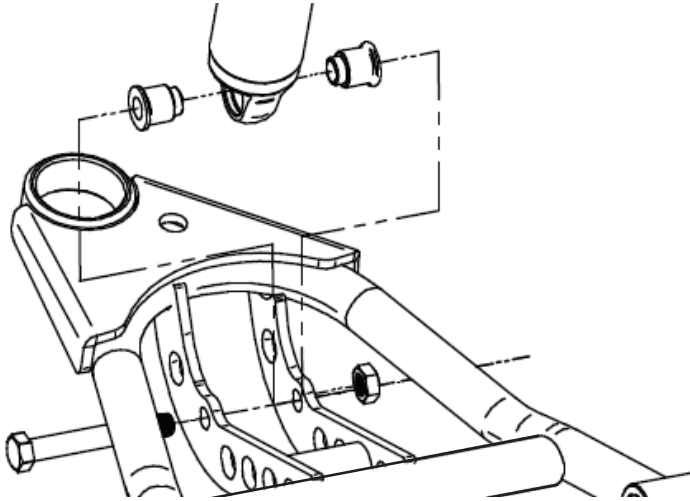

8. Insert the bearing spacers into the lower shock bearing. The SMALL end goes into the bearing. Swing the control arm up, line up the 1/2" holes with the bearing spacers, insert 1/2"-13 x 3 1/2" bolt. Install a 1/2" flat washer and nylok nut. Torque to 75 ft-lbs.

9.



9. Attach the spindle to the control arms.

Torque Specs:

Lower Ball joint - 70 ft-lbs and tighten to line up cotter pin.

Install the cotter pin after tightening the ball joint nut.

10.



10. Thread the 3/8"-16 nut onto the 3/8"-16 x 1 1/4" bolt. Thread it into the front hole of the ball joint plate. You will need to adjust the steering stop to suite your needs. This setting will vary depending on wheel and tire size and other suspension components. Torque to 16 ft-lbs.



Part # 11283699 - 1965-1970 GM B-Body Front Upper StrongArms



Recommended Tools



1965-1970 GM B-Body Upper StrongArms Installation Instructions

Table of contents

- Page 17..... Upper Control Arm Components
- Page 18..... Getting Started & Installation
- Page 19..... Installing Spindle and Alignment

THESE CONTROL ARMS ARE DESIGNED TO BE USED WITH THE OEM SPINDLES.



Upper Control Arm ComponentsIn the box

Item #	Part Number	Description	QTY
1	90001296	Driver Upper Control Arm (Shown)	1
1	90001297	Passenger Upper Control Arm	1
2	90000905 kit	Upper Ball Joint Kit - Proforged # 101-10038	2
3	90000102	Cross Shaft	2
4	90001442	Delrin Bushing	4
5	90001290	Delrin Bushing Inner Sleeve	4
6	99373001	Outer Washer - Cross Shaft	4
7	99373005	3/8" Split Lock Washer -Cross Shaft	4
8	99371013	3/8"-24 x 1" Hex Bolt - Cross Shaft	4

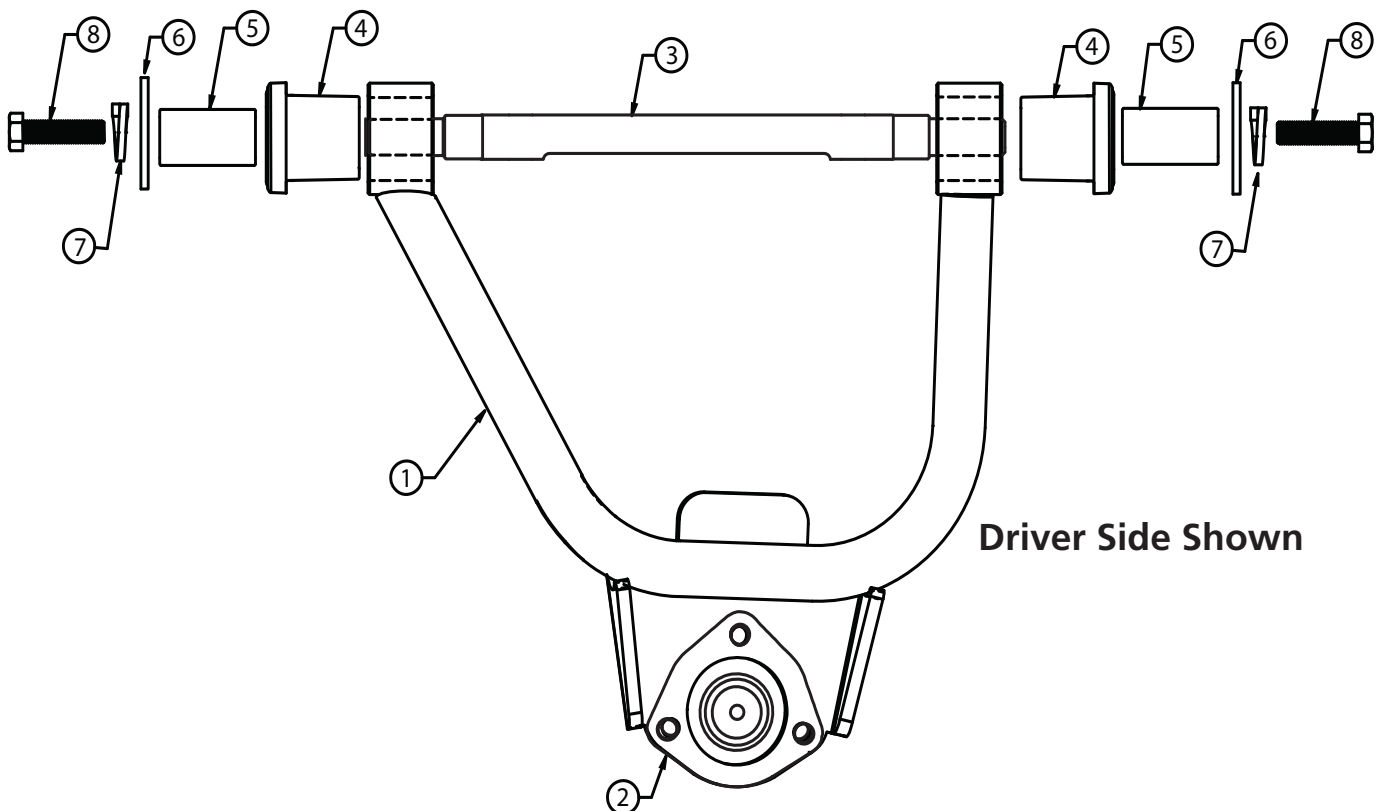



Getting Started.....

Congratulations on your purchase of the Ridetech StrongArms. These StrongArms have been designed to give your car excellent handling along with a lifetime of enjoyment. Some of the key features of the StrongArms: Ball joint angles have been optimized for the lowered ride height, Delrin bushings are used to eliminate bushing deflection along with providing free suspension movement through the entire travel. The Delrin bushings are made from a material that is self lubricating so no grease zerks are needed.

When assembling the Control Arms tighten the cross shaft bolts enough to create drag on the delrin bushings, the arm should still move through its travel by hand.

Installation

1. Remove the upper control arms from the car. Keep the shims separate so that you can put them back in the location they were removed from. If you are replacing the lower control arms and spindle, remove them too. Refer to a Factory Service Manual for the proper method.

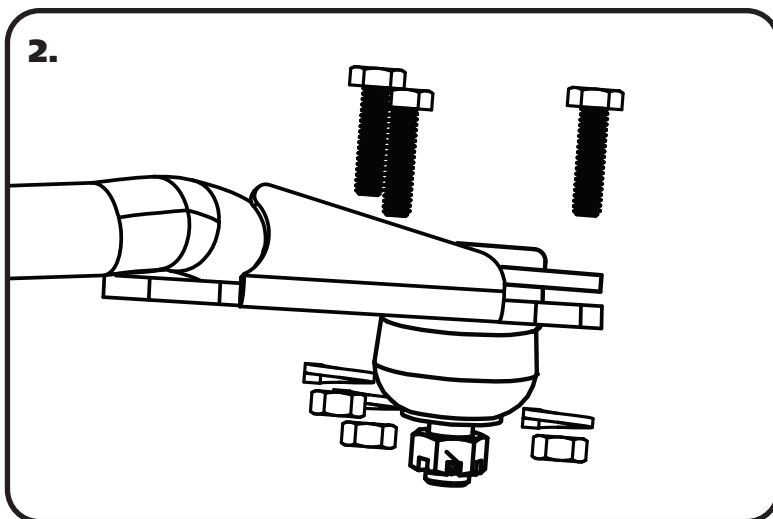

2. Insert the Ball Joint into the Control Arm from the TOP side with the Stud pointing downward. Insert the supplied Bolts from the top side. Install a Lock Washer and Hex Nut on the threads of each bolt. Torque the hardware to 18 ftlbs.

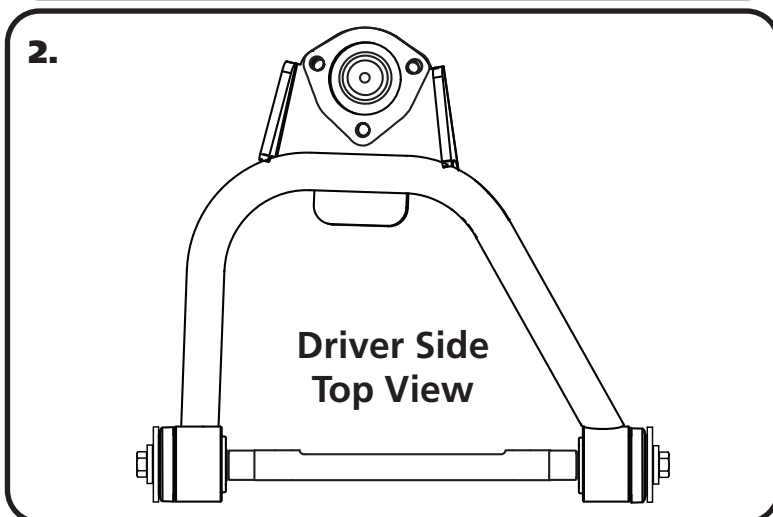

3. The Upper Control Arm is attached to the factory frame using factory hardware. The driver side arm is shown in **Figure "3"**. The Ball joint is located on the arm to the REAR of the car.



Installing Spindle and Alignment



4. The Upper Control Arm is attaching the factory mount using factory hardware. Reinstall the shims in the location they were removed from. The passenger side arm is shown in **Figure "4"**.

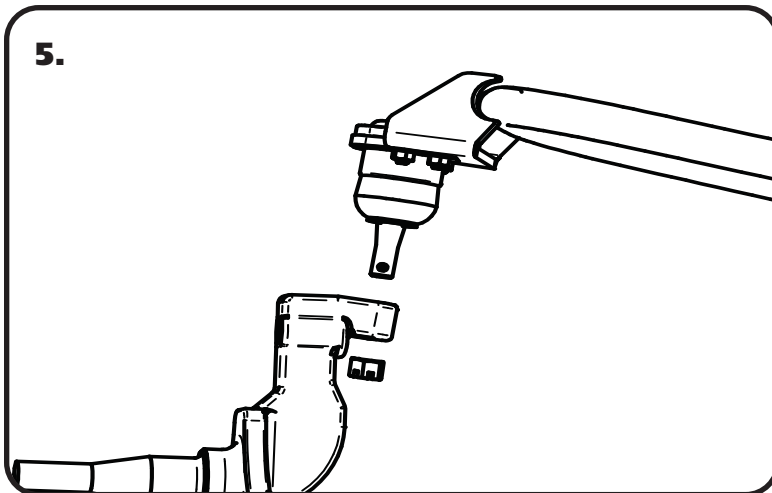

5. Attach the Spindle to the control arms. These control arms use a tall ball joint, the boot will NOT touch the spindle. This is normal.

Torque Specs:

Ball joint - 45 ftlbs and tighten to line up cotter pin.

Install the Cotter Pin after tightening the ball joint nut.

6. Tighten all fasteners.

When assembling the Control Arms tighten the cross shaft bolts enough to create drag on the delrin bushings, the arm should still move through its travel by hand.

Suggested Alignment Specs:

Camber: Street: -.5 degrees
Caster: Street: +3.0 to + 5.0 degrees
Toe: Street: 1/16" to 1/8" toe in



Part # 11286299 - 1965-1970 Full Size Chevy Rear CoilOver StrongArms



Recommended Tools

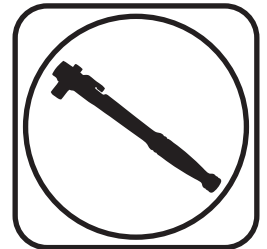

1965-1970 GM "B" Body Rear CoilOver StrongArms Installation Instructions

Table of contents

Page 21.....	Included Components
Page 22.....	Hardware & Getting Started
Page 23-24.....	Upper Mount Installation
Page 25-26.....	Lower StrongArm Installation
Page 26-27.....	CoilOver Installation





Included ComponentsIn the box

Item #	Part #	Description	QTY
1	90003179	Lower Control Arms	2
2	90003180	Upper Mount base plate	2
3	90002158	Universal Shock Mounting Bracket	2
4	90001357	Upper Clamp Plate	2
5	70013858	R-Joint Spacers - .625" ID x 1.00"	8
R-Joint Components - (Installed in bar ends)			
6	70013279	Retaining Ring	4
7	70013280	Wavo Wave Spring	4
8	70013275	R-Joint Center Ball	4
9	70013276	R-Joint Composite Center Ball Cage	4

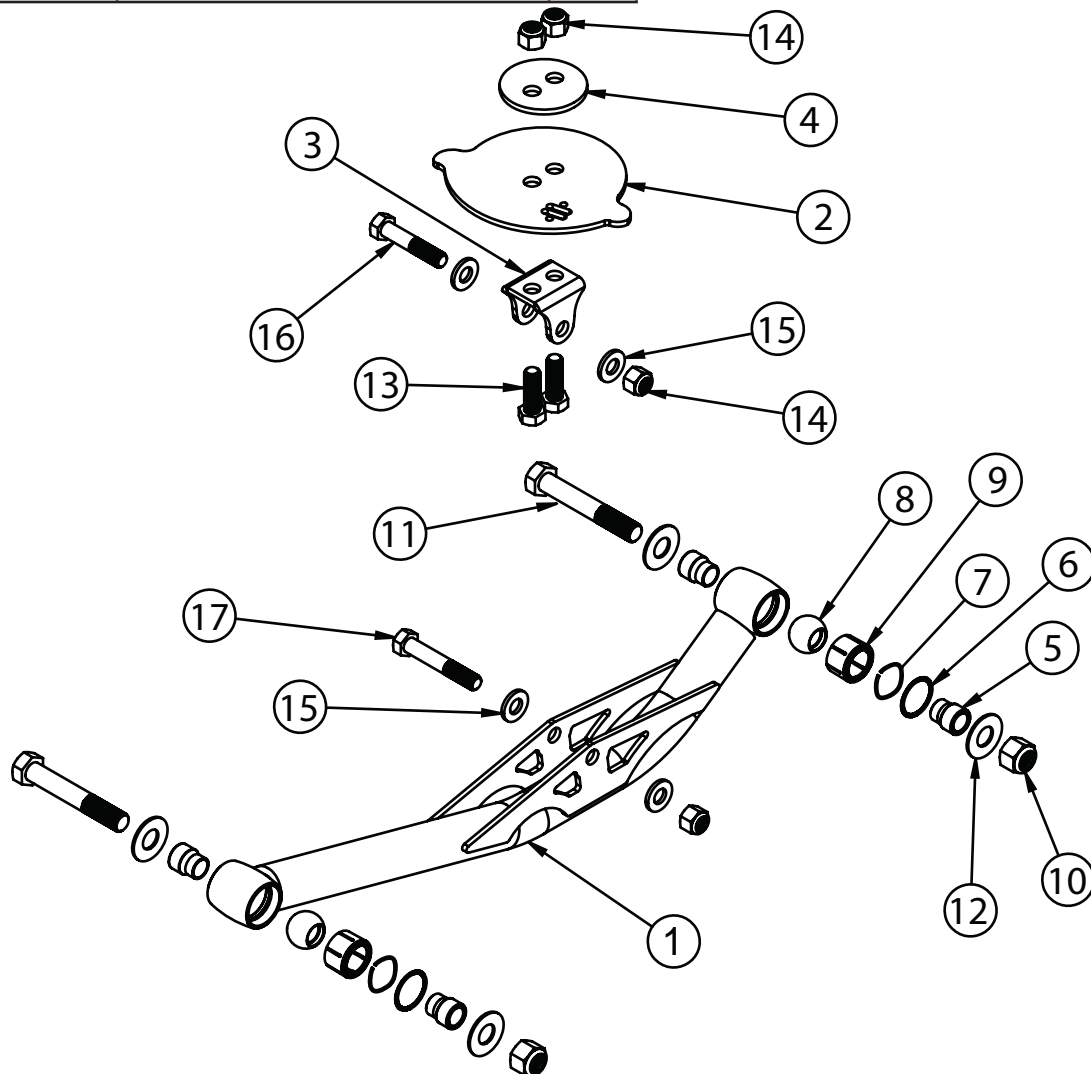



Hardware Kit..... #99010134

Item #	QTY	Part Number	Description	Item #	QTY	Part Number	Description
REAR UPPER CONTROL ARM				REAR COILOVER MOUNTING			
10	4	99622001	5/8"-18 Nylok Nut	14	4	99502009	1/2"-13 Nylok Nut
11	4	99621010	5/8"-18 x 4" Hex Bolt	15	8	99503014	1/2" SAE Flat Washer
12	8	99623001	5/8" SAE Flat Washer	16	2	99501050	1/2"-13 X 2 1/2" Hex Bolt
REAR UPPER SHOCK MOUNT				17	2	99501064	1/2"-13 X 2 3/4" Hex Bolt
13	4	99501053	1/2"-13 X 1 1/2" Hex Bolt				
14	4	99502009	1/2"-13 Nylok Nut				

R-JOINT SPACER INSTALLATION

Install the Spacers by inserting the SMALL side of the SPACER into the Center Pivot Ball. Push them in until they bottom out and stop.

LOWER R-JOINTS

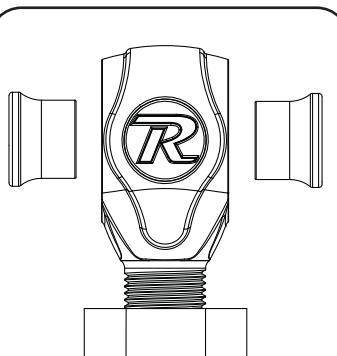

New R-Joints will be quite stiff (75-90 in/lbs breakaway torque) until they "break in" after a few miles of use. After the break in period they will move much more freely. Because the composite bearing race contains self lubricating ingredients, no additional lubrication is needed or desired. Any additional lubrication will only serve to attract more dirt and debris to the R-Joint and actually shorten its life.

Getting Started.....

Congratulations on your purchase of the Ridetech B-Body CoilOver StrongArms. These StrongArms have been designed to give your B-Body excellent handling along with a lifetime of enjoyment. Some of the key features of the StrongArm System: The StrongArms are designed to utilize a CoilOver Shock setup, R-Joints are used to eliminate bushing deflection along with providing free suspension movement through the entire travel. The R-Joints are made from a material that is self lubricating so no lubrication is needed.

Note: These control arms are designed for use with the Ridetech CoilOvers and the MuscleBar swaybar. **The factory shocks and springs will not fit these StrongArms. If you have a swaybar that attaches to the lower control arms, it will NOT work with these StrongArms.**

1. Raise the vehicle up to a comfortable work height. You will need the support the car by the frame to be able to freely raise and lower the rear axle. Use a jack under the differential to support it.
2. Remove the rear shocks, coil springs, and lower control arms.



Upper Mount Installation

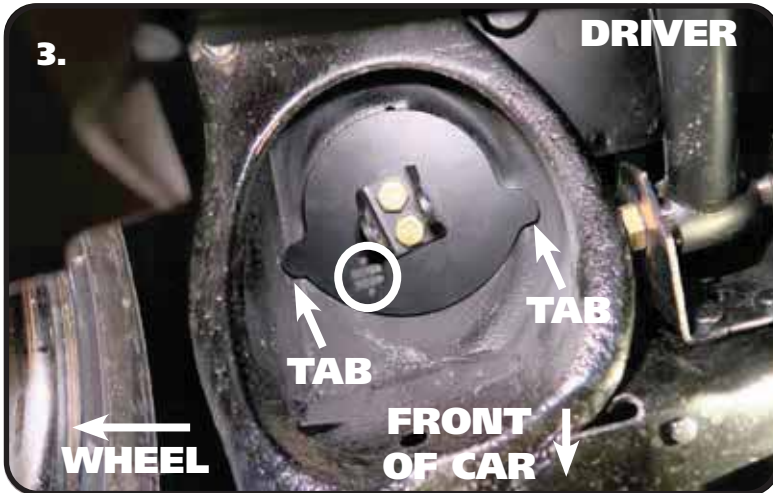

3. This kit contains a Upper Shock Mount setup that is designed to be mounted in a specific orientation. **Image 3** illustrates the proper orientation of the upper mount, we will cover the installation in the next steps. The upper mount is installed in the OEM coilspring pocket with the TABS of the upper plate to the front of the car. The Rideteck Icon(CIRCLED) needs to be toward the wheel. See **Image 3**.



4. The Upper Clamp Plate needs to be placed on the top side of the OEM coilspring pocket. It will fit down in the recessed area of the coilspring pocket. Use **Images 4 & 5** as a reference to install the upper clamp plate.



5. **Image 5** shows the Upper Clamp Plate in position as looking at it from the bottom side of the frame. Don't worry about the orientation of the bolt holes. You will position it correctly during the installation of the Upper Shock Mount.



Upper Mount Installation



6. The Upper Mount Assembly is attached to the frame using (2) 1/2"-13 x 1 1/2" Bolts. Insert the bolts through the shock mount and through the upper plate.



7. Position the Shock Mount/Plate up into the frame, holding the shock mount and hardware in place. **Position the mount with the tabs to the front of the car and Ridetech Icon toward the wheel.** You will need to align the upper clamp plate with the bolts that are sticking up through the frame.



8. Install a 1/2"-13 nylok nut on each of the bolts sticking through the frame and upper clamp plate. Torque the hardware to 75 ftlbs. Repeat for the second side of the car.



Lower StrongArm Installation



9. The Lower Control Arm has the bottom CoilOver mount built in. It will need to be installed with the CoilOver mount up and to the rear of the car. Install a 5/8" ID R-joint Spacer into the front R-joint. The Small Diameter goes into the R-joint. Slide the R-joint into the OEM lower control arm mount. Align the holes in the frame with the thru-hole of the R-Joint.



10. Install a 5/8" Flat Washer on a 5/8"-18 x 4" bolt. Insert the bolt/washer into the frame/R-Joint of the lower bar. Install a 5/8" flat washer and 5/8"-15 nylok nut on the threads of the bolt sticking through the frame. Tighten the hardware to eliminate any gaps.



11. Install the R-joint spacers into the rear R-Joints. Slide the rear of the lower control arm into the axle mount. Line up the mounting holes in the axle mount with the thru-hole of the R-joint.



Lower StrongArm & Shock Installation



12. Install a 5/8" flat washer on a 5/8"-18 x 4" bolt. Insert the bolt/washer through the mounting hole. Install a 5/8" flat washer and 5/8"-15 nylok nut on the threads of the bolt sticking through the axle mount. Tighten the hardware to eliminate any gaps



13. Refer to the CoilOver instructions that are included with the CoilOvers for proper CoilOver assembly. Insert the SHORT shock bearing t-bushings into the bearing of the **shock body**. The SMALL diameter of the t-bushings will insert into the shock bearing.



14. Insert the shock into the upper mount, lining up the holes of the mount and shock bearing/spacers. Install a 1/2" flat washer on a 1/2"-13 x 2 1/2" bolt. Insert the bolt/washer into the upper mount/shock. Install a 1/2" flat washer and 1/2"-13 nylok nut and Torque to 50 ftlbs.

Note: For ease of adjustment, the shock needs to be mounted with the shock body up.



Shock Installation



15. Insert the LONG shock bearing t-bushings into the bearing of the shock eyelet. The SMALL diameter of the t-bushings will insert into the shock bearing.



16. Insert the shock into the lower control arm with the adjuster knob to the front of the car. Line up the holes of the mount and shock. Install a 1/2" flat washer on a 1/2"-13 x 2 3/4" bolt. Insert the bolt/washer into the upper mount/shock. Install a 1/2" flat washer and 1/2"-13 nylok nut and Torque to 50 ftlbs.

Note: If the shock knob is not facing the correct direction, you can turn it as needed.



Part # 11296698 - 1965-1966 Full Size Chevy Rear Upper StrongArm Kit

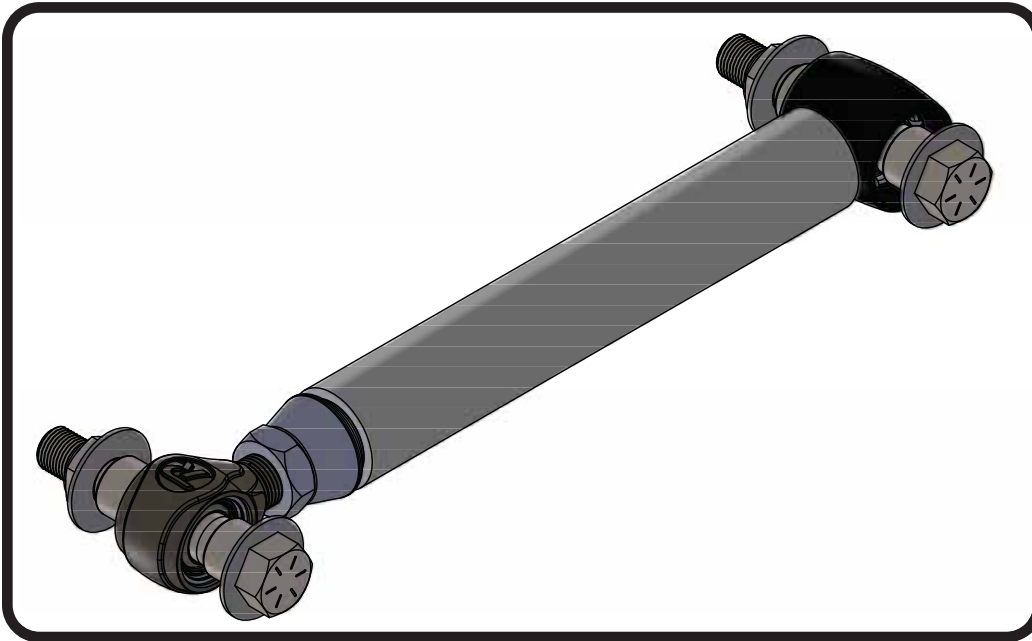

Recommended Tools



1965-1966 GM "B" Body Rear Upper StrongArms Installation Instructions

Table of contents

Page 29..... Included Components
Page 30..... Installation

Some vehicles have two factory upper arms and need a second tubular arm, Kit # 11296698.





Included ComponentsIn the box

Item #	Part #	Description	QTY
1	90002850	Upper StrongArm - set to 12.8125"	1
2	70013544	R-Joint Spacers	4
3	90001318	Standard 3/4"-16 R-Joint	1
4	99752004	3/4"-16 Jam Nut	1
R-Joint Components - (Installed in bar ends)			
5	70013279	Retaining Ring	1
6	70013280	Wavo Wave Spring	1
7	70013275	R-Joint Center Ball	1
8	70013276	R-Joint Composite Center Ball Cage	1

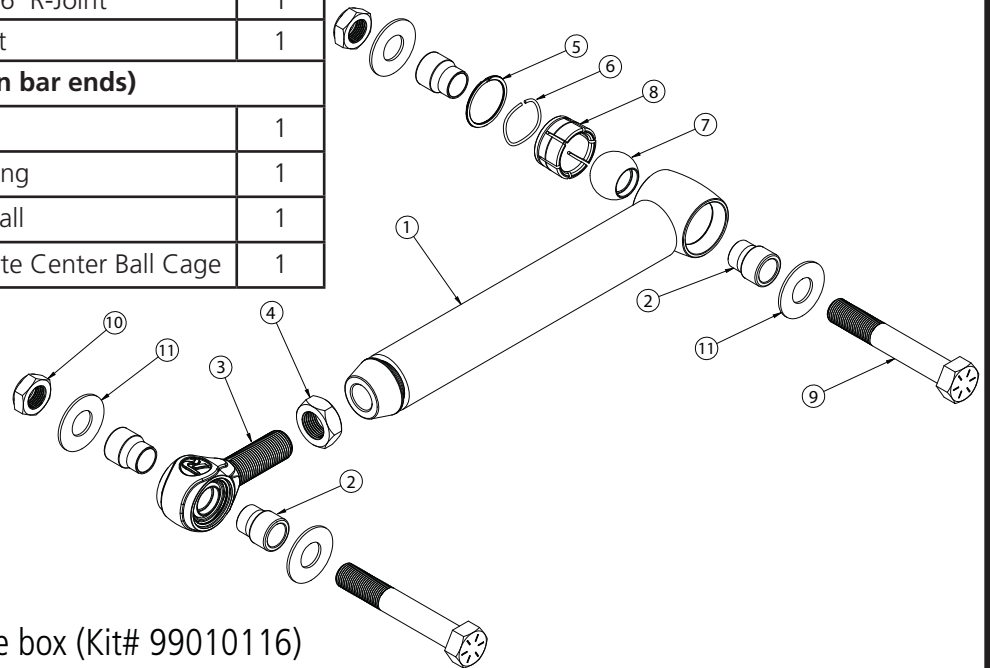

Hardware ListIn the box (Kit# 99010116)

Item #	QTY	Part Number	Description
REAR UPPER CONTROL ARM			
9	2	99621010	5/8"-18 x 4" Bolt
10	2	99622006	5/8"-18 Nylok Nut
11	4	99623001	5/8" SAE Flat Washer

R-JOINT SPACER INSTALLATION

Install the Spacers by inserting the SMALL side of the SPACER into the Center Pivot Ball. Push them in until they bottom out and stop.

UPPER R-JOINTS

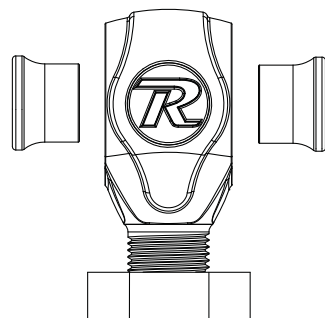

New R-Joints will be quite stiff (75-90 in/lbs breakaway torque) until they "break in" after a few miles of use. After the break in period they will move much more freely. Because the composite bearing race contains self lubricating ingredients, no additional lubrication is needed or desired. Any additional lubrication will only serve to attract more dirt and debris to the R-Joint and actually shorten its life.



Upper Bar Installation



1. Insert the small diameter of the R-Joint Spacers into the center ball of the R-Joint. Insert the R-Joint/Spacers into the OEM mount of the differential.



2. Install a 5/8" flat washer on a 5/8"-18 x 4" hex bolt through the mount and control arm R-Joint. Install a 5/8" flat washer, followed by a 5/8"-18 nylok jam nut onto the threads of the bolt. Tighten the hardware enough to eliminate any gaps.

REPEAT THE ABOVE STEPS FOR THE FRAME SIDE OF THE UPPER STRONG ARM.



Part # 11289000 - 1965-1970 Full Size Chevy Adjustable Panhard Kit

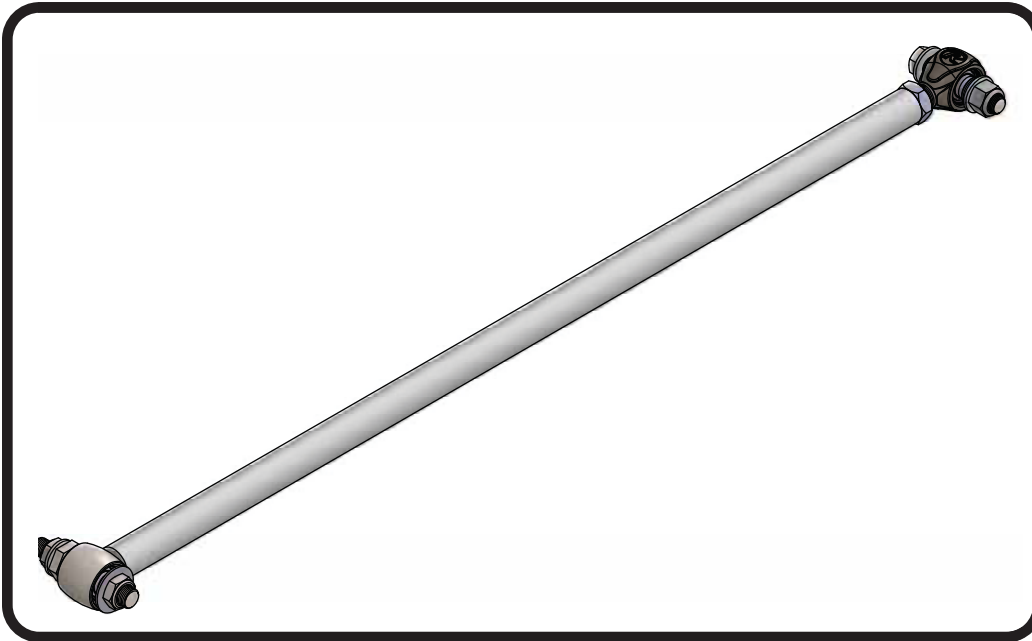

Recommended Tools

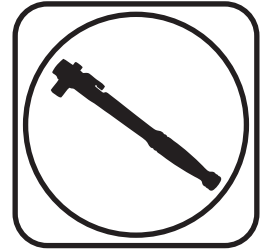

1965-1970 GM "B" Body Adjustable Panhard Kit Installation Instructions

Table of contents

Page 32..... Included Components & Hardware
Page 33-34..... Installation





Included ComponentsIn the box

Item #	Part #	Description	QTY
1	90002827	Panhard Bar - set to 35.750"	1
2	90000461	Panhard Stud	1
3	70013334	R-Joint Spacers - Stud	2
4	90001318	Standard 3/4"-16 R-Joint	1
5	99752004	3/4"-16 Jam Nut	1
6	70013764	R-Joint Spacers - Frame	2
R-Joint Components - (Installed in bar ends)			
7	70013279	Retaining Ring	1
8	70013280	Wavo Wave Spring	1
9	70013275	R-Joint Center Ball	1
10	70013276	R-Joint Composite Center Ball Cage	1

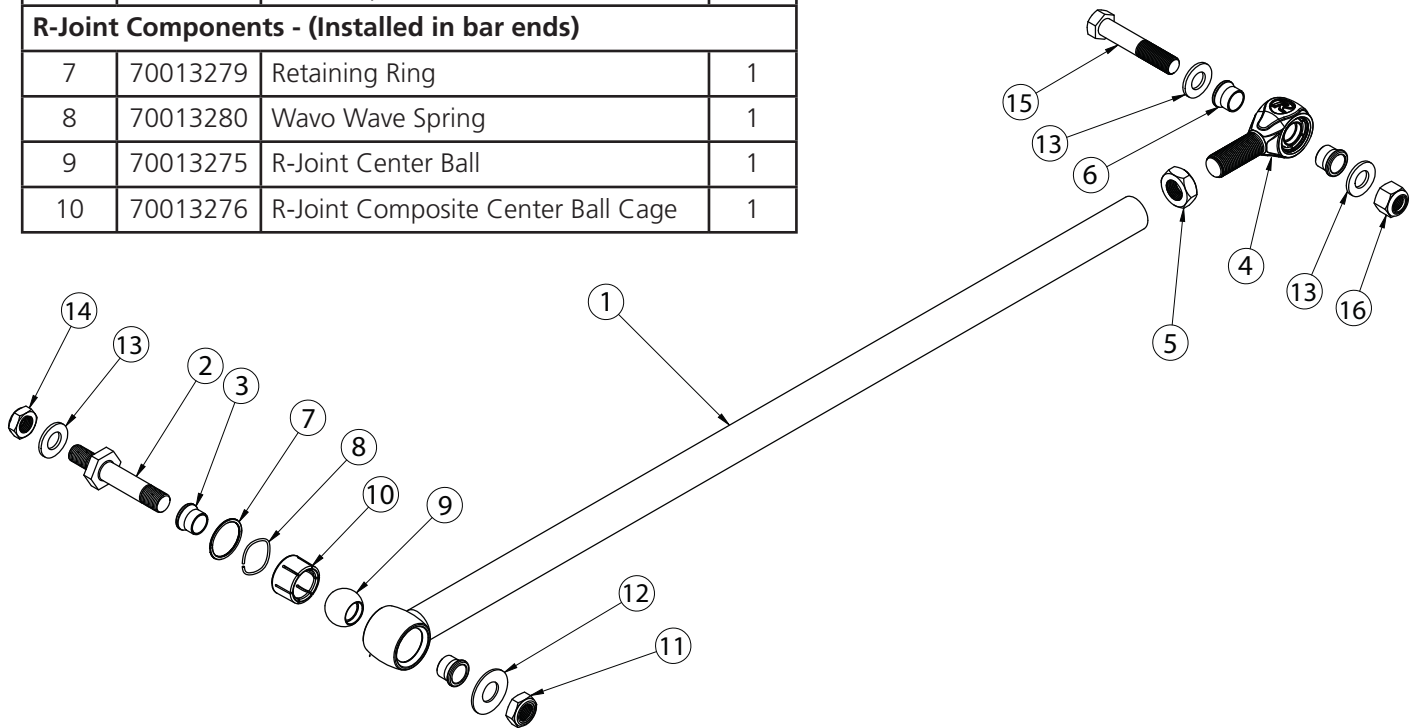

Hardware ListIn the box (Kit# 99010123)

Item #	QTY	Part Number	Description
PANHARD BAR STUD			
11	1	99622006	5/8"-18 Nylok Jam Nut
12	1	99623001	5/8" SAE Flat Washer
13	1	99566003	9/16" SAE Flat Washer
14	1	99562001	9/16"-18 Nylok Nut
PANHARD BAR FRAME MOUNT			
13	2	99566003	9/16" SAE Flat Washer
15	1	99561003	9/16"-18 x 3" Bolt
16	1	99562003	9/16"-18 Nylok Jam Nut



R-Joint Spacer Installation

R-JOINT SPACER INSTALLATION

Install the Spacers by inserting the SMALL side of the SPACER into the Center Pivot Ball. Push them in until they bottom out and stop.

UPPER R-JOINTS

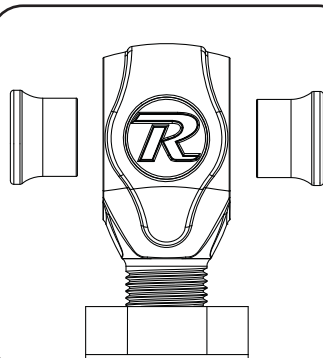

New R-Joints will be quite stiff (75-90 in/lbs breakaway torque) until they "break in" after a few miles of use. After the break in period they will move much more freely. Because the composite bearing race contains self lubricating ingredients, no additional lubrication is needed or desired. Any additional lubrication will only serve to attract more dirt and debris to the R-Joint and actually shorten its life.

The Panhard bar can be removed from the car with it sitting at any height, but the car will need to be at ride height when checking the sided to side dimensions. It may be necessary to adjust the panhard bar to center the differential in the car at ride height.

1. Remove the OEM panhard bar from the car.
2. Remove the panhard bar stud from the rear differential.

Panhard Bar Installation



1. Bolt the new panhard bar stud into the OEM location of the axle using the 9/16" flat washer and 9/16"-18 Nylok nut supplied in the kit. Torque to 95 ftlbs.



Panhard Bar Installation



2. Install a Narrow 5/8" ID R-joint Spacers into each side of the R-joint of either end of the Panhard Bar. The Small Diameter goes into the R-joint. Slide the R-joint onto the stud and fasten in place with a 5/8" flat washer and 5/8"-18 thin jam nylok nut. Torque to 95 ftlbs.



3. Install the 3/4" jam nut onto the end of the R-Joint end, then screw R-Joint end into the end of the panhard bar. Set the Panhard Bar to 35.750". You may need to readjust it after getting the car set at ride height, but this is a good starting point. Press the SMALL diameter of the 9/16" I.D. R-Joint spacers into each side of the center ball of the remaining R-Joint. Push the spacers in until they bottom out in the center ball.

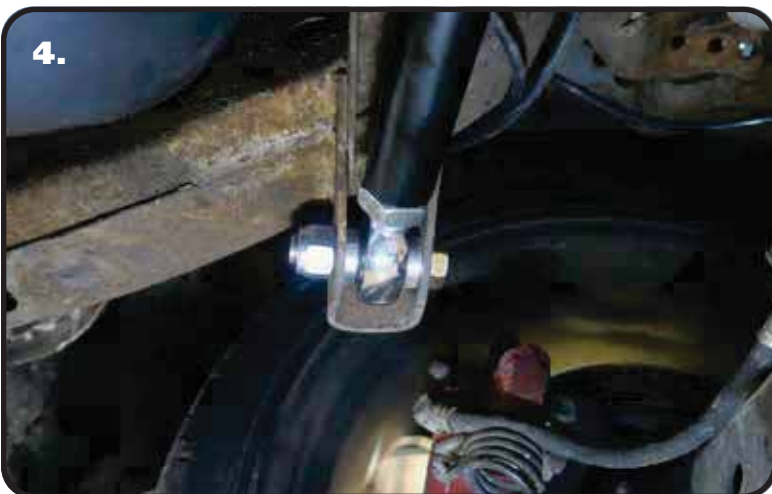

4. Insert the R-Joint Housing end of the panhard bar into the OEM frame mount. Align the align hole in the R-Joint end with the holes in the OEM mount. Install a 9/16" flat washer on a 9/16"-18 x 3" hex bolt and insert in into the aligned holes. Install a 2nd 9/16" washer followed by a 9/16"-18 nylok nut on the threads of the bolt sticking through the frame. Torque to 95 ftlbs.

5. Check the side to side dimension between the tire and quarter panel with the car at ride height. You may need to adjust the panhard bar to center the axle at ride height.



Part # 11286210 - 1965-1970 B-Body Rear CoilOvers

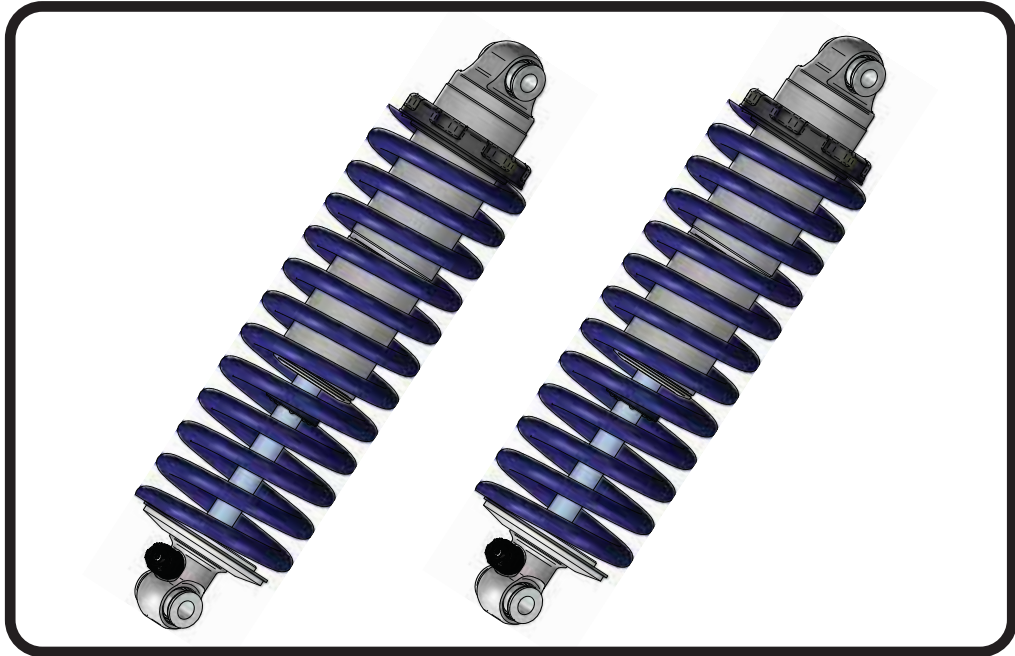

Recommended Tools



1965-1970 B-Body HQ Series Rear Coilovers Installation Instructions

Table of contents	
Page 36.....	Included components
Page 37.....	Assembly and Adjusting
Page 38.....	Final Adjusting and Preloading the Spring

CoilOver Dimensions:	
Center of bearing to Center of bearing:	
Compressed:	9.43"
Ride Height:	11.50"
Extended:	13.03"



Major ComponentsIn the box

Item #	Part #	Description	QTY
1	982-10-803	3.6" Stroke HQ Series Shock	2
2	815-05-022-KIT	1.7" Shock Eyelet	2
4	59080575	Coilspring 8" 575lb	2
5	70010828	Delrin Spring Washer	4
6	803-00-199(kit)	Lower Spring Adjuster Nut (803-00-199 kit)	2
7	803-00-199(kit)	Adjuster Nut Locking Screw (803-00-199 kit)	2
8	803-00-199(kit)	Retaining Ring (803-00-199 kit)	2
9	90002043	Shock Bearing Spacers - .605" long	4
10	90002040	Shock Bearing Spacers - .740" long	4
	90001994	5/8" ID Bearing (installed in shock and eyelet)	4
	90001995	Bearing Snap Ring (installed in shock and eyelet)	8

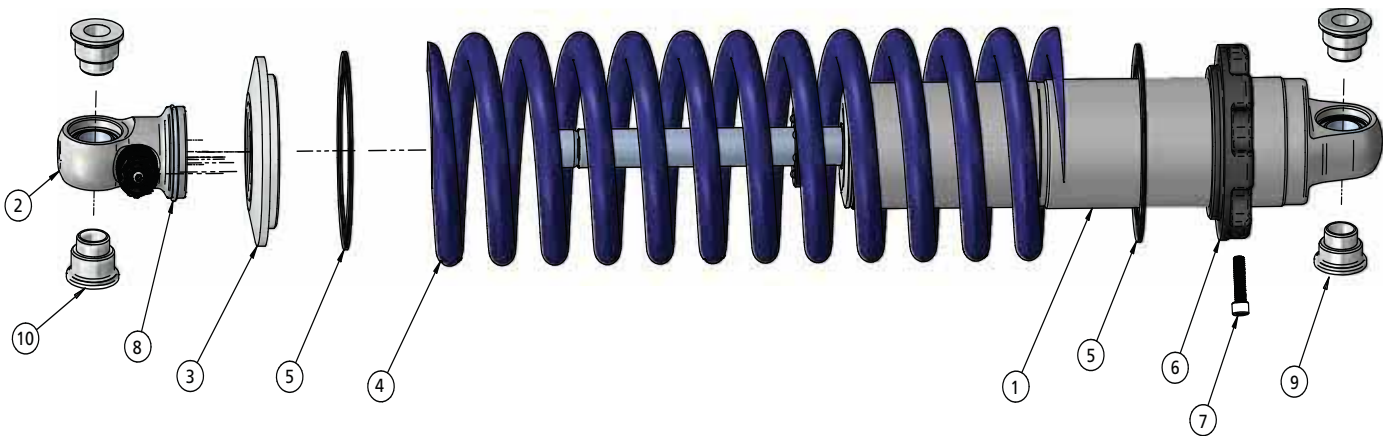

CoilOver Assembly...



1

First, using the supplied lower adjuster nut (803-00-199) thread the nut onto the shock from the bottom side as seen in figure 1. Remove the plastic pellet that is in the split of the adjuster nut.



4

Once the knob is removed slide a Delrin washer over the eyelet. Next, slide the upper spring mount (803-00-199) over eyelet as seen in figure 4.



2

Next, install a delrin washer then coil spring over the top of the shock as seen in figure 2.



5

Install upper spring mount retainer clip (803-00-199) into the groove on the upper eyelet as seen in figure 5. Then, reinstall adjuster to complete assembly.



3

Before the upper spring mount can be installed screw the adjuster knob on the upper eye mount to the firmest setting (clockwise) as seen in figure 3. Then remove the Knob by holding it while removing the center screw.

Install the locking screw in the adjuster nut before setting spring preload, but DO NOT tighten until the spring preload has been set.

NOTE: Remember to adjust the shock valving before driving, the shock is currently set to full stiff.

Shock Adjustment 101- Single Adjustable

Rebound Adjustment:

How to adjust your new shocks.

The rebound adjustment knob is located on the top of the shock absorber protruding from the eyelet.

You must first begin at the ZERO setting, then set the shock to a medium setting of 12.



-Begin with the shocks adjusted to the ZERO rebound position (full stiff). Do this by rotating the rebound adjuster knob clockwise until it stops.



-Now turn the rebound adjuster knob counter clock wise 12 clicks. This sets the shock at 12. (settings 21-24 are typically too soft for street use).

Take the vehicle for a test drive.



-if you are satisfied with the ride quality, do not do anything, you are set!

-if the ride quality is too soft increase the damping effect by rotating the rebound knob clock wise 3 clicks.

Take the vehicle for another test drive.



-if the vehicle is too soft increase the damping effect by rotating the rebound knob clock wise 3 additional clicks.



-If the vehicle is too stiff rotate the rebound adjustment knob counter clock wise 2 clicks and you are set!

Take the vehicle for another test drive and repeat the above steps until the ride quality is satisfactory.

Note:

One end of the vehicle will likely reach the desired setting before the other end. If this happens stop adjusting the satisfied end and keep adjusting the unsatisfied end until the overall ride quality is satisfactory.



Final Tightening and Adjusting

Ride Height

We have designed most cars to have a ride height of about 2" lower than factory. To achieve the best ride quality & handling, the shock absorber needs to be at 40-60% overall travel when the car is at ride height. This will ensure that the shock will not bottom out or top out over even the largest bumps. Measuring the shock can be difficult, especially on some front suspensions. Measuring overall wheel travel is just as effective and can be much easier. Most cars will have 4-6" of overall wheel travel. One easy way to determine where you are at in wheel travel is to take a measurement from the fender lip (center of the wheel) to the ground. Then lift the car by the frame until the wheel is just touching the ground, re-measure. This will indicate how far you are from full extension of the shock. A minimum of 1.5" of extension travel (at the wheel) is needed to ensure that the shock does not top out. If you are more than 3" from full extension of the shock then you are in danger of bottoming out the shock absorber.

Adjusting Spring Height

When assembling the CoilOver, screw the spring retainer tight up to the spring (0 preload). After entire weight of car is on the wheels, jounce the suspension and roll the car forward and backward to alleviate suspension bind.

- If the car is too high w/ 0 preload then a smaller rate spring is required. Although threading the spring retainer down would lower the car, this could allow the spring to fall out of its seat when lifting the car by the frame.
- If the car is too low w/ 0 preload, then preload can then be added by threading the spring retainer up to achieve ride height. On 2.6" - 4" stroke shocks, up to 1.5" of preload is acceptable. On 5-7" stroke shocks, up to 2.5" of preload is acceptable. If more preload is needed to achieve ride height a stiffer spring rate is required. Too much preload may lead to coil bind, causing ride quality to suffer.



Part # 11289102 - 1965-1970 GM B-Body Rear SwayBar



Recommended Tools

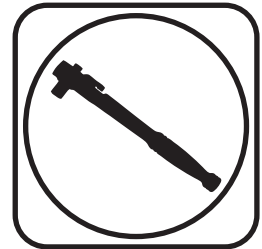

1965-1970 GM B-Body Rear SwayBar Installation Instructions

Table of contents	
Page 40.....	Included Components and Hardware List
Page 41-42.....	SwayBar Installation
Page 43.....	SwayBar Installation and Adjustment

Hardware Torque Specifications	
3/8"-16.....	30 ftlbs
7/16"-20.....	55 ftlbs
M10-1.5.....	37 ftlbs

Major ComponentsIn the box

Part #	Description	QTY
90002410	Rear SwayBar	1
90000740	Axle Bracket, 3" Axle Tube	2
90001250	Bushing Strap	2
70015012	Lined Sway Bar Bushing	2
90001251	1965-1966 Frame Tab, Driver	1
90001252	1965-1966 Frame Tab, Passenger	1
90002411	1967-1970 Frame Tab, Driver	1
90002412	1967-1970 Frame Tab, Passenger	1
70014301	Clamp Ring	2
70014207	Clamp On SwayBar End	2
90002571	10mm 90 Degree End Links	4
90001253	SwayBar End Link Spacer, 4"	2
90000088	7/16" U-bolt	2

HARDWARE KIT.....99010084

QTY	Part Number	Description
TAB TO FRAME		
4	99371005	3/8"-16 x 1 1/4" Hex Bolt
4	99373002	3/8" Flat Washer
4	99372001	3/8"-16 Nylok Nut

QTY	Part Number	Description
SWAYBAR TO AXLE		
4	99433002	7/16" SAE Flat Washer
4	99432002	7/16"-20 Nylok Nut
SWAYBAR END CLAMP		
4	99371054	3/8"-16 x 7/8" Socket Head Bolt
1	90002276	Antisieze

Getting Started.....

This sway bar kit utilizes a anti-friction lining in the sway bar bushing. The lining allows the sway bar to move freely and quietly in the bushing. No lubrication is required.

The kit contains 2 different sets of frame brackets to accommodate the different frame variations. One set of frame brackets fit 1965-1966, the 2nd set of frame brackets fits 1967-1970. **Steps 11a & 11b** illustrate the differences between the brackets.

THIS SWAYBAR ATTACHES TO THE AXLE AND FRAME.

1. Jack the vehicle up to a safe working height and support with jack stands. Make sure the jack stands are stable before working under the car.

2. Remove the stock sway bar if the car is equipped with one.



3. Open the sway bar bushing at the split and slip it **OVER** the sway bar. Do this for both bushings.

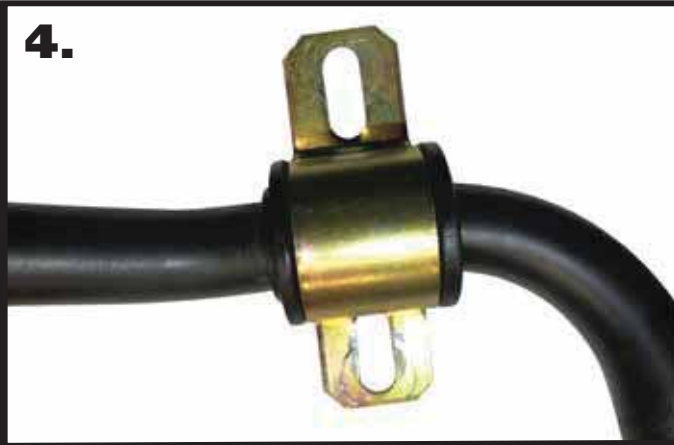

4.

4. Install the Bushing Straps over the SwayBar Bushings.



5.

5. Install the U-bolts onto the axle tube with the threads pointing down. You may need to raise the brake lines in the area of the u-bolts. The u-bolts will be approximately 23 1/2" apart and equal distance on each side from the brake backing plates



6.

6. Install an Axle bracket onto each u-bolt with the flat side to toward the ground.

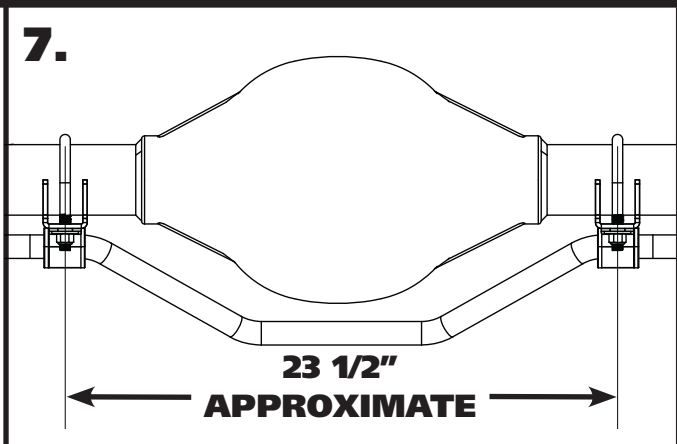

7.

7. **Diagram 7**, illustrates the correct installation of the sway bar. Again, the axle brackets will be approximately 23 1/2" from center to center. The mounts should be spaced equal amounts from the brake backing plates, centering the sway bar on the axle.



8.

8. Hold the SwayBar in position on the car with the center bend toward the ground. Install a 7/16" Flat Washer & 7/16"-20 Nylok Nut on the threads of the u-bolts. Snug the hardware down and verify the swaybar is centered and the axle mounts are level. Torque the u-bolt hardware.



9.

9. Apply Antisieze to (4) 3/8"-16 x 7/8" Socket Head Cap Screws and thread them into the Clamp-On Ends. Install a clamp-on end on each end of the bar. The End Link mounting hole should be mounted to the outside of the bar and pointing down. Start with the mount flush with the end of the bar.

DRIVER

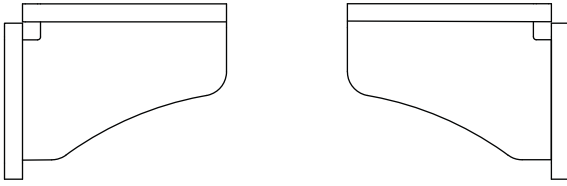
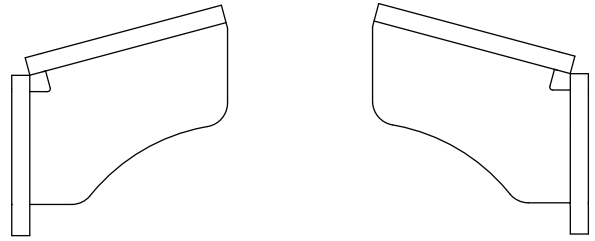
10a.**1965 - 1966****DRIVER****PASSENGER****AS VIEWED FROM THE REAR OF THE CAR****10b.****1967 - 1970****DRIVER****PASSENGER****AS VIEWED FROM THE REAR OF THE CAR**

10a & 10b. Diagrams 10a & 10b are to help you determine the correct frame brackets for your car. The brackets in **10a** fit, 1965-1966. The mounting holes are perpendicular to the sway bar linkage tab. The brackets in **10b**, fit 1967-1970. The mounting holes in the 1967-1970 brackets are angled. Both sets of brackets are viewed from the rear as they would be installed on the car. Each bracket has a **RIDETECH** logo stamped in the front side.

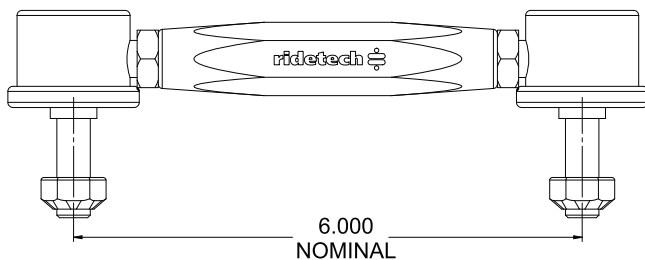
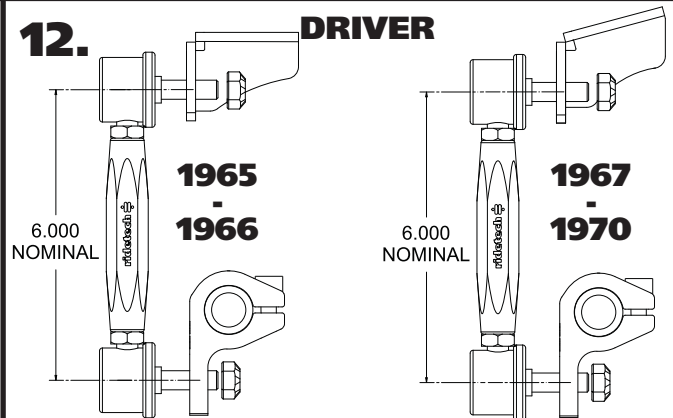
11.6.000
NOMINAL**12.****DRIVER****1965
1966****1967
1970**6.000
NOMINAL6.000
NOMINAL

11. Assemble the end links. Thread the jam nut up the shank of the 90° end link. Thread and end link end each end of the center adjuster until they reach the jam nuts. Thread the end links out evenly until you have a measurement of 6" from center to center of the 90° ends. The studs of the 90° ends need to be pointing in the same direction. Snug the jam nuts against the center adjuster.

12. Determine the correct frame bracket for your year of car. Attach the SwayBar Linkage to the Clamp-On Mount using the hardware on the linkage. Attach the correct tab to the top of the linkage with the gusset to the front. Use **Diagram 12** as a reference. Attach the linkages and tab to both sides.

13.

13. Swing the tab up to the frame, keeping the linkage straight from side to side. Use the tab to mark the location of the holes that will need to be drilled. Drill the holes with a 3/8" drill bit. Install a 3/8" flat washer on each of (2) 3/8"-16 x 1 1/4" hex bolts and install them through the bracket and drilled holes. Install a 3/8" flat washer & 3/8"-16 nylok nut on each bolts sticking through the frame. Torque the hardware and repeat on the other side.

14.

14. Install the locking rings on the inside of each bushing assembly. Use a hex key to take the locking ring apart. Reassemble it on the bar positioned next to the outside of the bushing assembly. Push the locking ring up against the bushing assembly and tighten.

15. MINIMUM RATE 177 LB/INCH

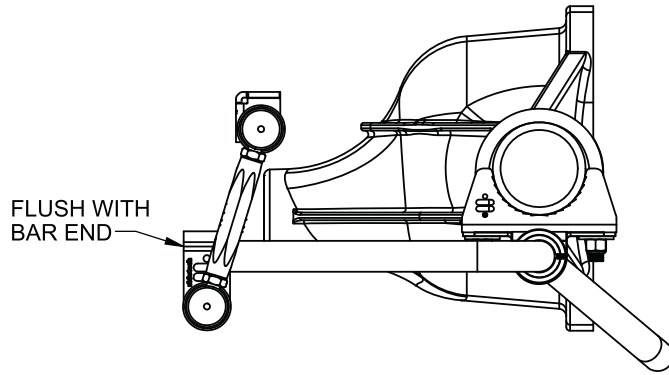

HIGH RATE 255 LB/INCH

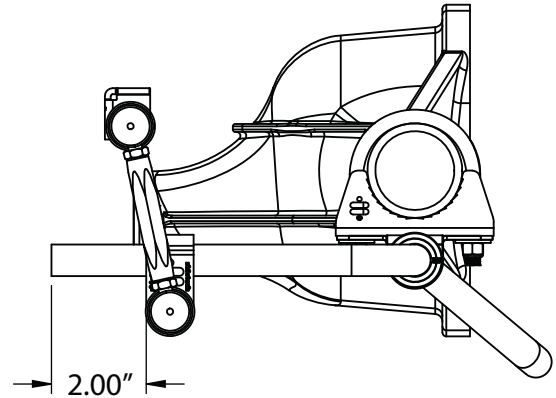

15. We recommend getting the swaybar as level as possible at ride height and with no preload. Both of these steps are done by adjusting the end links. These end links can be adjusted from 6" to 6 3/4". Disconnect the end links from the swaybar and adjust one side to get the swaybar level. Reattach the end link to the swaybar and adjust the 2nd end link so that it goes in and out of the clamp-on mount with ease. This will be zero preload.

The rate of this sway bar is also adjustable. This is possible by changing the position of the clamp-on ends on the bar. The standard setting is with the clamp-on mounts even with the end of the bar, stiffest is with the clamp-on end positioned 2" from the end of the swaybar. The Diagram above shows the clamp-on mount in the softest and stiffest settings. The position of the mounts will be determined by several factors; spring rate, front bar size, and even tire size. We recommend running this rear sway bar with Ridetech's front sway bar (11289120) for the best performance.