



### Part # 11296699 - 1965-1966 GM "B" Body Rear Strong Arm Kit

#### Kit Components:

11296698	Rear Upper Strong Arm
11289000	Rear Adjustable Panhard Kit

#### Recommended Tools

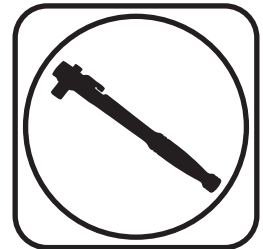

## 1965-1966 GM "B" Body Strong Arms Installation Instructions

#### Table of contents

Pages 2-4.....	Upper Strong Arms
Pages 5-8.....	Adjustable Panhard Bar

Some vehicles have two factory upper arms and need a second tubular arm, Kit # 11296698.





**Part # 11296698** - 1965-1966 Full Size Chevy Rear Upper StrongArm Kit

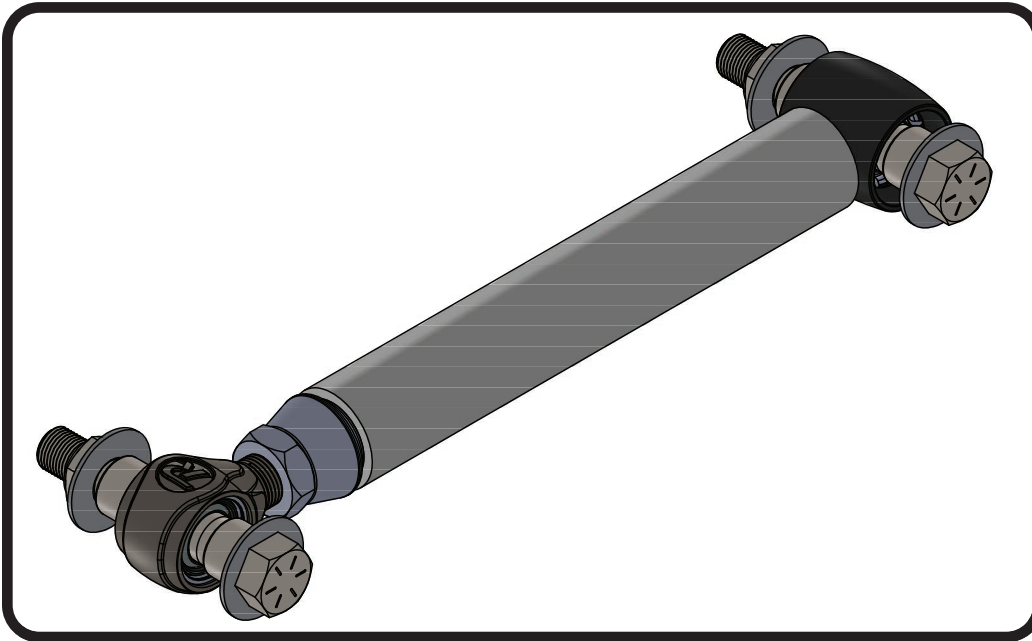

Recommended Tools

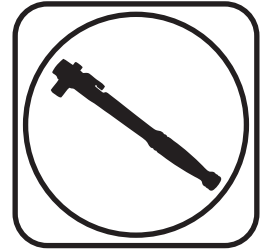

## 1965-1966 GM "B" Body Rear Upper StrongArms Installation Instructions

### Table of contents

Page 3..... Included Components  
Page 4..... Installation

Some vehicles have two factory upper arms and need a second tubular arm, Kit # 11296698.





### Included Components ....In the box

Item #	Part #	Description	QTY
1	90002850	Upper StrongArm - set to 12.8125"	1
2	70013544	R-Joint Spacers	4
3	90001318	Standard 3/4"-16 R-Joint	1
4	99752004	3/4"-16 Jam Nut	1
<b>R-Joint Components - (Installed in bar ends)</b>			
5	70013279	Retaining Ring	1
6	70013280	Wavo Wave Spring	1
7	70013275	R-Joint Center Ball	1
8	70013276	R-Joint Composite Center Ball Cage	1

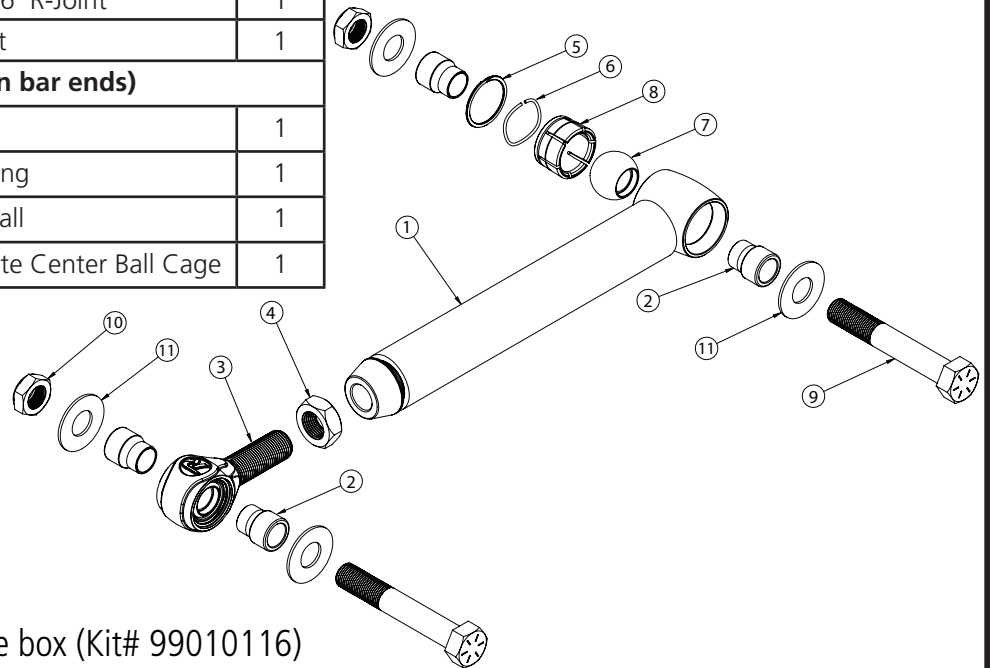

### Hardware List ....In the box (Kit# 99010116)

Item #	QTY	Part Number	Description
<b>REAR UPPER CONTROL ARM</b>			
9	2	99621010	5/8"-18 x 4" Bolt
10	2	99622006	5/8"-18 Nylok Nut
11	4	99623001	5/8" SAE Flat Washer

#### R-JOINT SPACER INSTALLATION

Install the Spacers by inserting the SMALL side of the SPACER into the Center Pivot Ball. Push them in until they bottom out and stop.

#### UPPER R-JOINTS

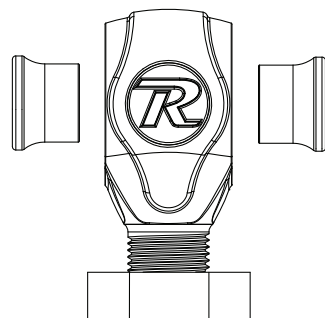

New R-Joints will be quite stiff (75-90 in/lbs breakaway torque) until they "break in" after a few miles of use. After the break in period they will move much more freely. Because the composite bearing race contains self lubricating ingredients, no additional lubrication is needed or desired. Any additional lubrication will only serve to attract more dirt and debris to the R-Joint and actually shorten its life.



### Upper Bar Installation

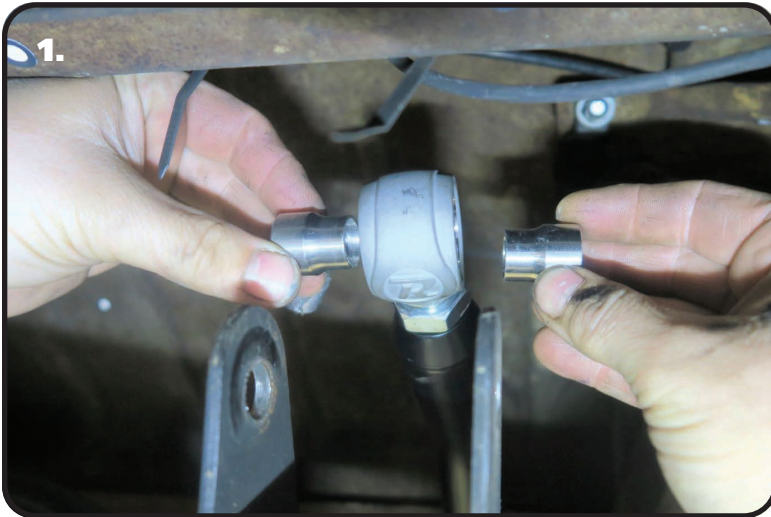

**1.** Insert the small diameter of the R-Joint Spacers into the center ball of the R-Joint. Insert the R-Joint/Spacers into the OEM mount of the differential.

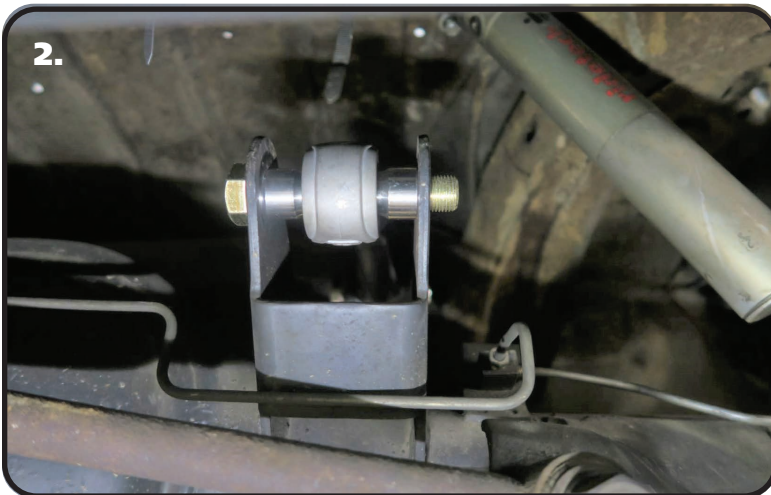

**2.** Install a 5/8" flat washer on a 5/8"-18 x 4" hex bolt through the mount and control arm R-Joint. Install a 5/8" flat washer, followed by a 5/8"-18 nylok jam nut onto the threads of the bolt. Tighten the hardware enough to eliminate any gaps.

REPEAT THE ABOVE STEPS FOR THE FRAME SIDE OF THE UPPER STRONG ARM.



**Part # 11289000 - 1965-1970 Full Size Chevy Adjustable Panhard Kit**

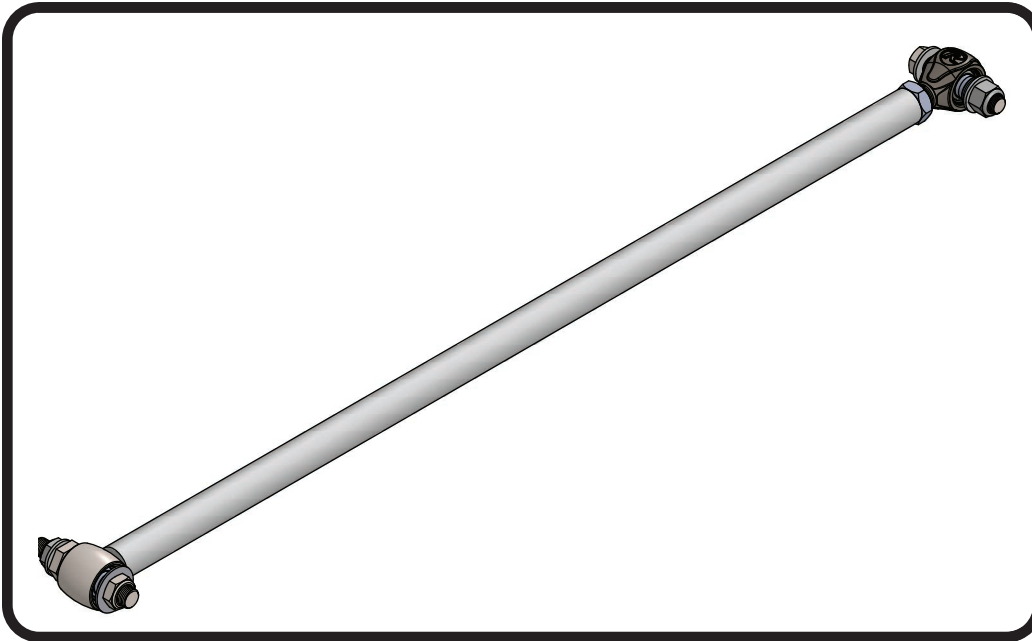

Recommended Tools

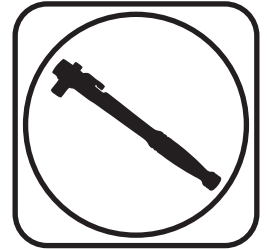

# 1965-1970 GM "B" Body Adjustable Panhard Kit Installation Instructions

## Table of contents

Page 6..... Included Components & Hardware  
Page 7-8..... Installation





### Included Components ....In the box

Item #	Part #	Description	QTY
1	90002827	Panhard Bar - set to 35.750"	1
2	90000461	Panhard Stud	1
3	70013334	R-Joint Spacers - Stud	2
4	90001318	Standard 3/4"-16 R-Joint	1
5	99752004	3/4"-16 Jam Nut	1
6	70013764	R-Joint Spacers - Frame	2
<b>R-Joint Components - (Installed in bar ends)</b>			
7	70013279	Retaining Ring	1
8	70013280	Wavo Wave Spring	1
9	70013275	R-Joint Center Ball	1
10	70013276	R-Joint Composite Center Ball Cage	1

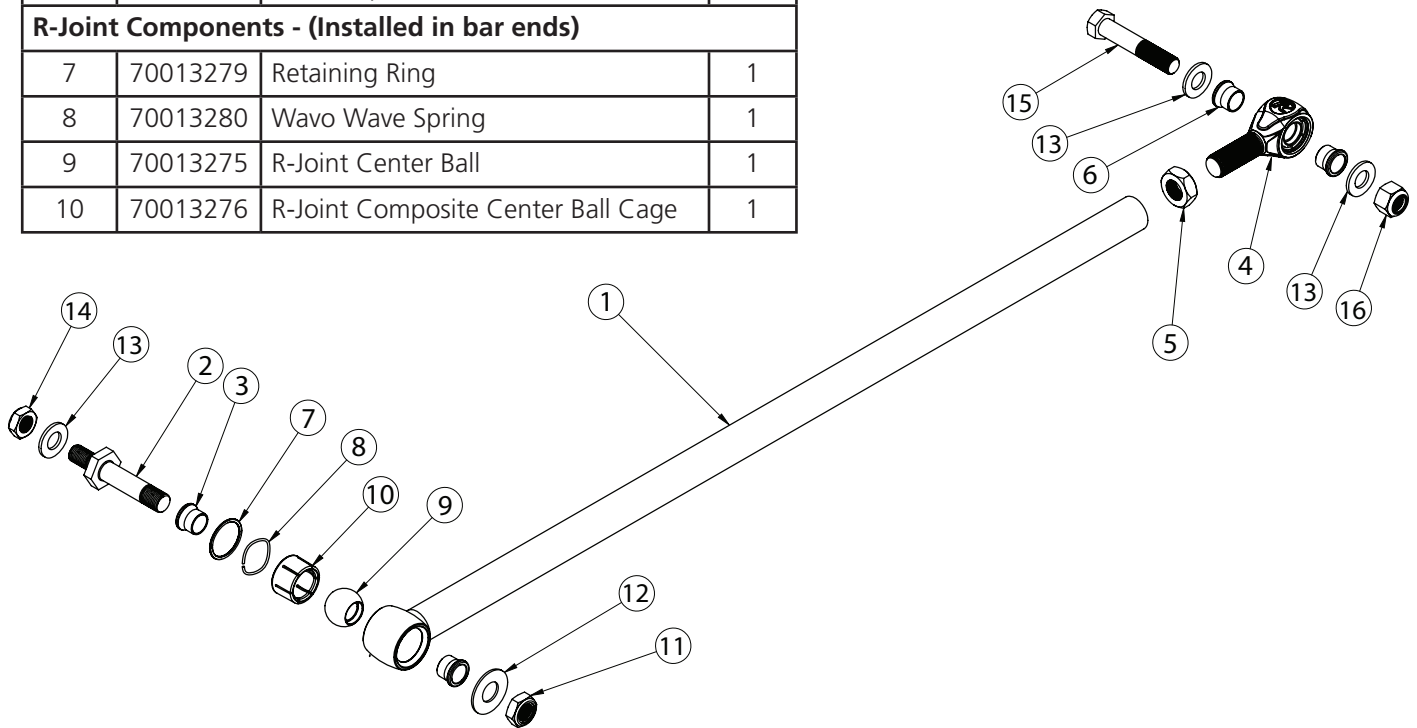

### Hardware List ....In the box (Kit# 99010123)

Item #	QTY	Part Number	Description
<b>PANHARD BAR STUD</b>			
11	1	99622006	5/8"-18 Nylok Jam Nut
12	1	99623001	5/8" SAE Flat Washer
13	1	99566003	9/16" SAE Flat Washer
14	1	99562001	9/16"-18 Nylok Nut
<b>PANHARD BAR FRAME MOUNT</b>			
13	2	99566003	9/16" SAE Flat Washer
15	1	99561003	9/16"-18 x 3" Bolt
16	1	99562003	9/16"-18 Nylok Jam Nut



### R-Joint Spacer Installation

#### R-JOINT SPACER INSTALLATION

Install the Spacers by inserting the SMALL side of the SPACER into the Center Pivot Ball. Push them in until they bottom out and stop.

#### UPPER R-JOINTS

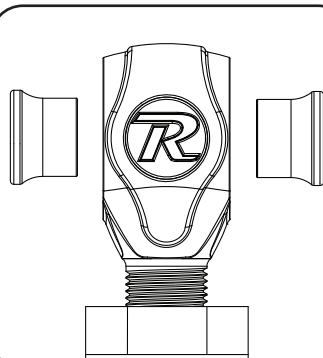

New R-Joints will be quite stiff (75-90 in/lbs breakaway torque) until they "break in" after a few miles of use. After the break in period they will move much more freely. Because the composite bearing race contains self lubricating ingredients, no additional lubrication is needed or desired. Any additional lubrication will only serve to attract more dirt and debris to the R-Joint and actually shorten its life.

The Panhard bar can be removed from the car with it sitting at any height, but the car will need to be at ride height when checking the sided to side deminsions. It may be necessary to adjust the panhard bar to center the differential in the car at ride height.

1. Remove the OEM panhard bar from the car.
2. Remove the panhard bar stud from the rear differential.

### Panhard Bar Installation



1. Bolt the new panhard bar stud into the OEM location of the axle using the 9/16" flat washer and 9/16"-18 Nylok nut supplied in the kit. Torque to 95 ftlbs.



### Panhard Bar Installation



2. Install a Narrow 5/8" ID R-joint Spacers into each side of the R-joint of either end of the Panhard Bar. The Small Diameter goes into the R-joint. Slide the R-joint onto the stud and fasten in place with a 5/8" flat washer and 5/8"-18 thin jam nylok nut. Torque to 95 ftlbs.



3. Press the SMALL diameter of the 9/16" I.D. R-Joint spacers into each side of the center ball of the remaining R-Joint. Push the spacers in until they bottom out in the center ball.

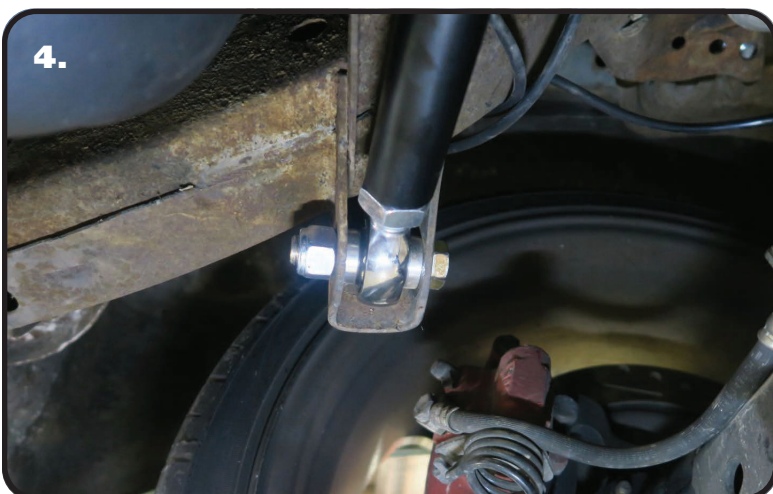

4. Insert the R-Joint Housing end of the panhard bar into the OEM frame mount. Align the align hole in the heim end with the holes in the OEM mount. Install a 9/16" flat washer on a 9/16"-18 x 3" hex bolt and insert in into the aligned holes. Install a 2nd 9/16" washer followed by a 9/16"-18 nylok nut on the threads of the bolt sticking through the frame. Torque to 95 ftlbs.

5. Check the side to side dimension between the tire and quarter panel with the car at ride height. You may need to adjust the panhard bar to center the axle at ride height.