

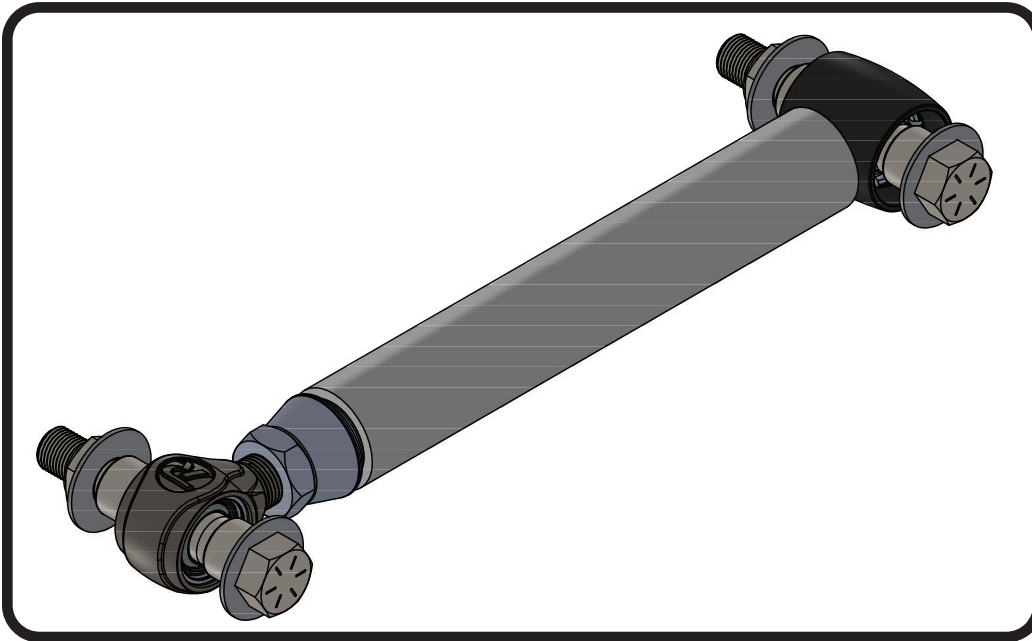

**Part # 11306698** - 1967-1970 Full Size Chevy Rear Upper StrongArm Kit

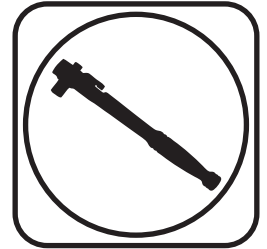

Recommended Tools



## 1967-1970 GM "B" Body Rear Upper StrongArms Installation Instructions

### Table of contents

Page 2..... Included Components  
Page 3..... Installation

Some vehicles have two factory upper arms and need a second tubular arm, Kit # 11306698.



[www.ridetech.com](http://www.ridetech.com)





### Included Components ....In the box

Item #	Part #	Description	QTY
1	90002851	Upper StrongArm - set to 10.00"	1
2	70013544	R-Joint Spacers	4
3	90001318	Standard 3/4"-16 R-Joint	1
4	99752004	3/4"-16 Jam Nut	1
<b>R-Joint Components - (Installed in bar ends)</b>			
5	70013279	Retaining Ring	1
6	70013280	Wavo Wave Spring	1
7	70013275	R-Joint Center Ball	1
8	70013276	R-Joint Composite Center Ball Cage	1

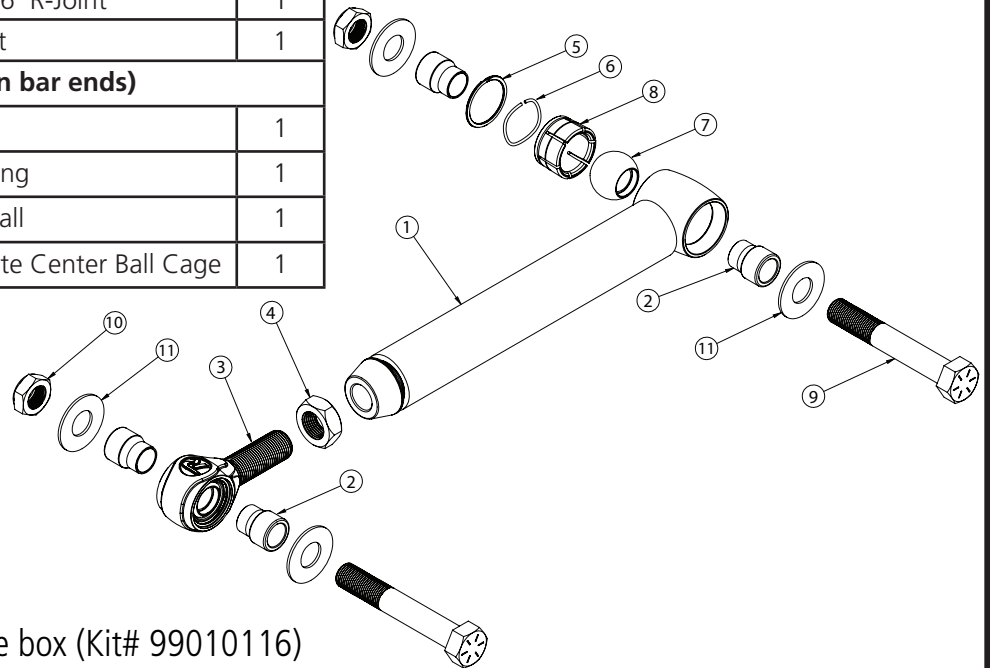

### Hardware List ....In the box (Kit# 99010116)

Item #	QTY	Part Number	Description
<b>REAR UPPER CONTROL ARM</b>			
9	2	99621010	5/8"-18 x 4" Bolt
10	2	99622006	5/8"-18 Nylok Nut
11	4	99623001	5/8" SAE Flat Washer

#### R-JOINT SPACER INSTALLATION

Install the Spacers by inserting the SMALL side of the SPACER into the Center Pivot Ball. Push them in until they bottom out and stop.

#### UPPER R-JOINTS

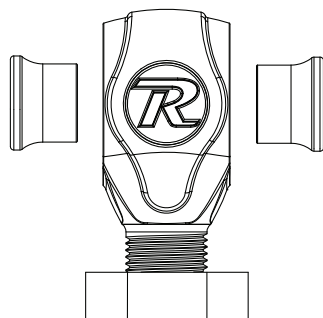

New R-Joints will be quite stiff (75-90 in/lbs breakaway torque) until they "break in" after a few miles of use. After the break in period they will move much more freely. Because the composite bearing race contains self lubricating ingredients, no additional lubrication is needed or desired. Any additional lubrication will only serve to attract more dirt and debris to the R-Joint and actually shorten its life.



### Upper Bar Installation

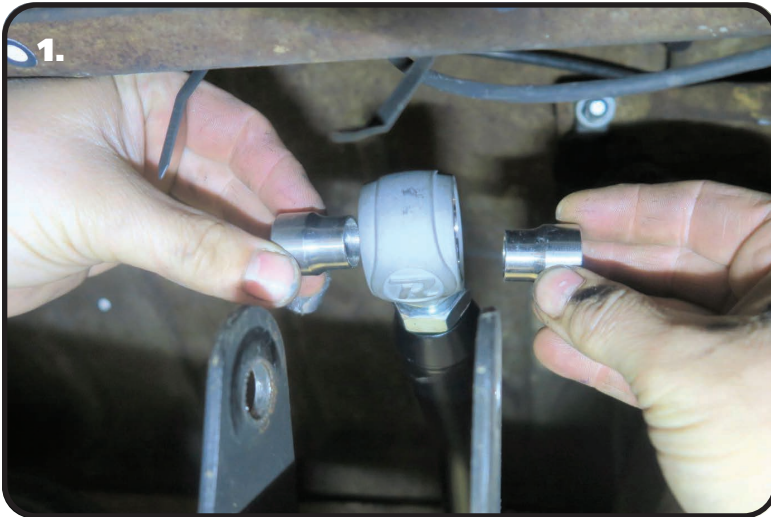

**1.** Insert the small diameter of the R-Joint Spacers into the center ball of the R-Joint. Insert the R-Joint/Spacers into the OEM mount of the differential.

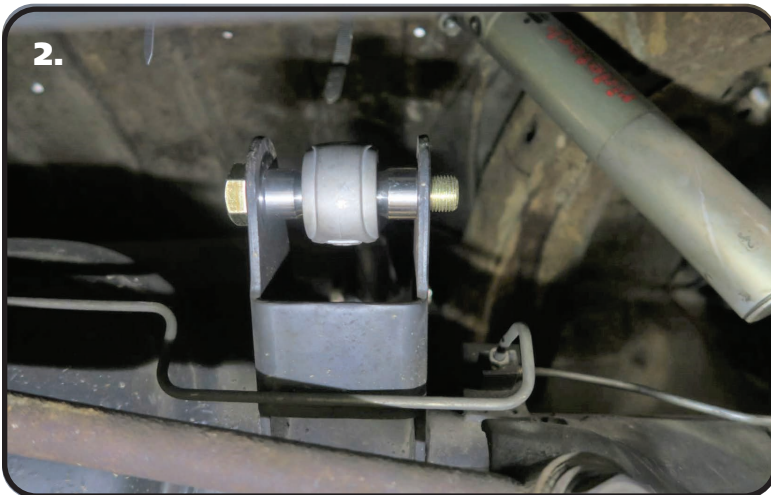

**2.** Install a 5/8" flat washer on a 5/8"-18 x 4" hex bolt through the mount and control arm R-Joint. Install a 5/8" flat washer, followed by a 5/8"-18 nylok jam nut onto the threads of the bolt. Tighten the hardware enough to eliminate any gaps.

REPEAT THE ABOVE STEPS FOR THE FRAME SIDE OF THE UPPER STRONG ARM.