

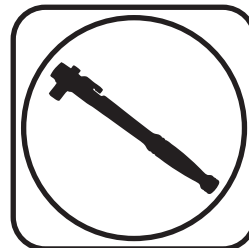

Part # 11329120 - 1978-1988 GM G-Body Front SwayBar

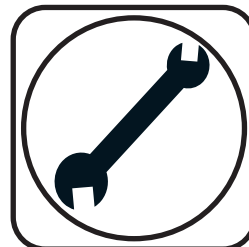

Recommended Tools



1978-1988 GM G-Body Front SwayBar Installation Instructions

Table of contents
Page 2..... Included Components and Hardware List
Page 3-4..... SwayBar Installation

Hardware Torque Specifications

M10-1.5.....	37 ftlbs
3/8"-16.....	30 ftlbs

Major ComponentsIn the box

Part #	Description	QTY
90001227	Front SwayBar	1
90002936	End Link Kit	1
90001346	Bushing Strap	2
70015015	Lined Sway Bar Bushing	2
90001254	Bushing Mount Adapter	2
70014210	Frame Brace Spacers	4

HARDWARE KIT.....99010085

QTY	Part Number	Description
ADAPTER PLATE		
2	99111001	M10-1.5 X 30MM Flat Head Bolt
2	99111002	M10-1.5 X 30MM Hex Head Bolt
2	99113001	M10 Split Lock Washer
2	99433002	7/16" SAE Flat Washer
1	90002263	Red Loctite

QTY	Part Number	Description
FRAME BRACE SPACERS		
4	99111004	M10-1.5 X 60MM Hex Head Bolt
2	99112002	M10-1.5 Nylok Nut
2	99113001	M10-1.5 X Split Lock Washer
6	99433002	7/16" SAE Flat Washer
BUSHING STRAP		
4	99371065	3/8"-16 x 3/4" Hex Bolt
4	99373002	3/8" Flat Washer
4	99373006	3/8" Split Lock Washer

Getting Started.....

Note: This sway bar kit utilizes a anti-friction lining in the sway bar bushing. The lining allows the sway bar to move freely and quietly in the bushing. No lubrication is required.

1. Jack the vehicle up to a safe working height and support with jack stands. Make sure the jack stands are stable before working under the car.
2. Remove the stock sway bar.
3. After removing the stock sway bar, determine what size hardware the frame will require.



4. If your car is equipped with front frame braces, remove them for now. They will get reinstalled later in the instructions.



5. Open the sway bar bushing at the split and slip it **OVER** the sway bar. Do this for both bushings.



6.

6. Slip the Bushing Straps over the SwayBar Bushings.

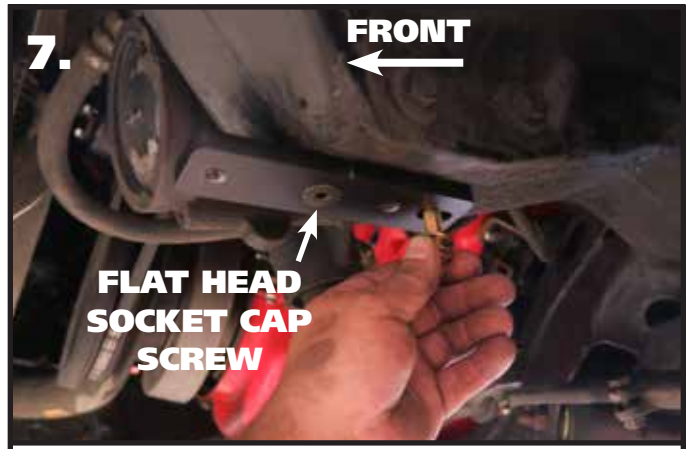

7.

FLAT HEAD
SOCKET CAP
SCREW

FRONT
←

7. Hold the Frame Plate up to the OEM holes, the Counter Sunk hole will be positioned over the front hole with the slot to the rear. Apply Red Loctite to the Flat Head Bolt. The rear 30mm long bolt uses a Split Washer and Flat Washer. Torque Hardware.



8.

8. Slide the SwayBar into position on the car with the SwayBar arms above the tie rods. Install a 3/8" Lock Washer & 3/8" Flat Washer on the 3/8"x 3/4" Hex Bolts. Do **NOT** Complete tighten the Hardware, it will be left partially loose until the End Links are installed.

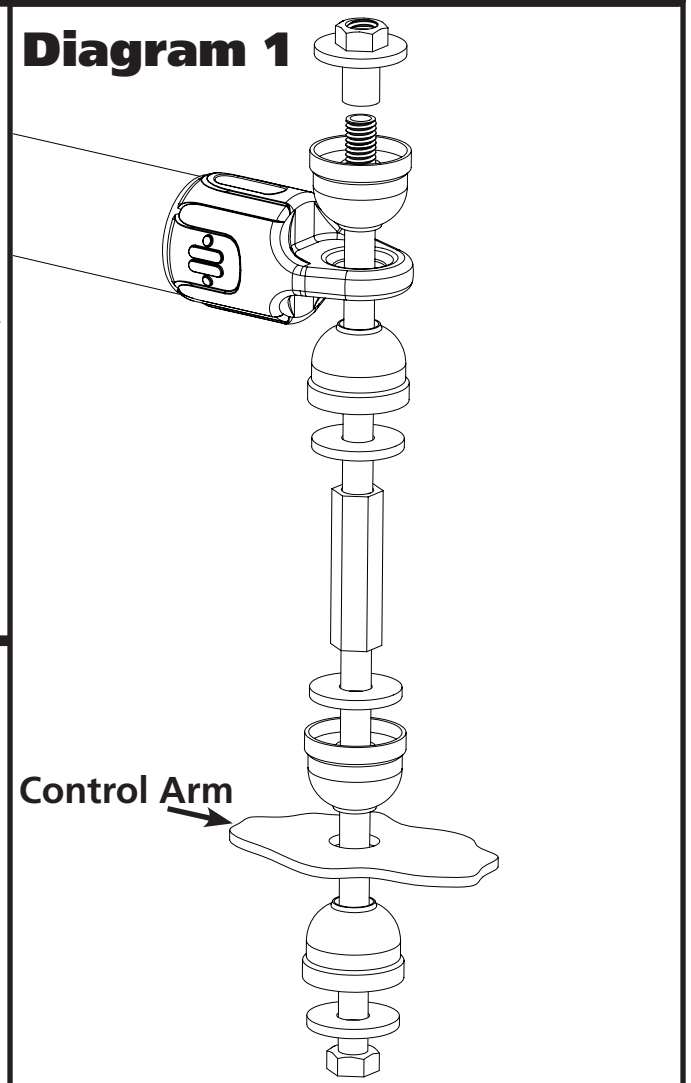

Diagram 1

Control Arm



9

9. Install the End Links using **Diagram 1** as a reference. Install both end links before tightening the end link hardware. Tighten the end link barrel nut until it is flush with the end of the bolt, and then tighten it 2 more complete rounds.

10. Torque the SwayBar mounting hardware.



11.

11. This swaybar requires the frame brace to be spaced down for clearance. Starting with the rear, install a flat washer, and lock washer on each of (2) M10-1.5 x 60mm bolts and insert them into the holes of the frame brace. Slide the Spacer onto the bolt with the SMALL diameter against the brace.

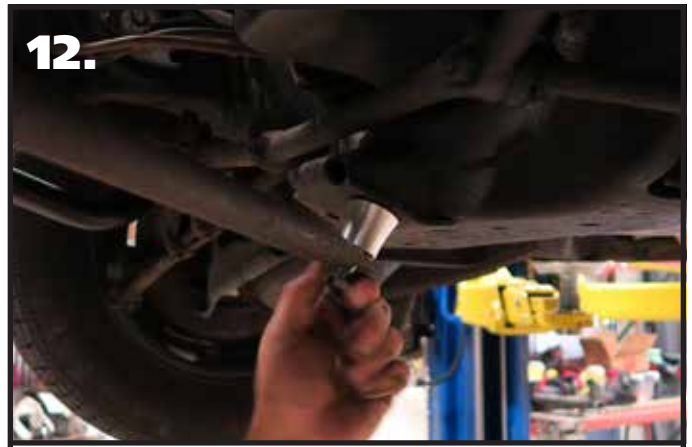

12.

12. Hold the Frame Brace up in position and thread the bolts into the OEM threaded holes. Leave them loose for now.



13.

13. Install a Flat Washer onto each of the (2) remaining M10-1.5 x 60mm bolts and insert them into the holes of the frame brace. Slide the Spacer onto the bolt with the SMALL diameter against the brace.



14.

14. Push the Brace up and line up the bolt with the OEM mounting holes. While holding the bolt in position, install a Flat Washer & M10-1.5 Nylok Nut on the bolt. You will have to insert them through the large hole in the bottom of the frame. Torque the frame brace hardware.