

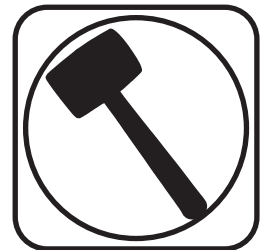

C10 CoolRide StrongArms

Part # 11343699(63-70)/**11353699**(71-72)/**11363699**(73-87)

Recommended Tools

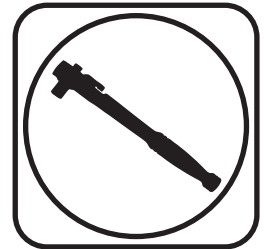
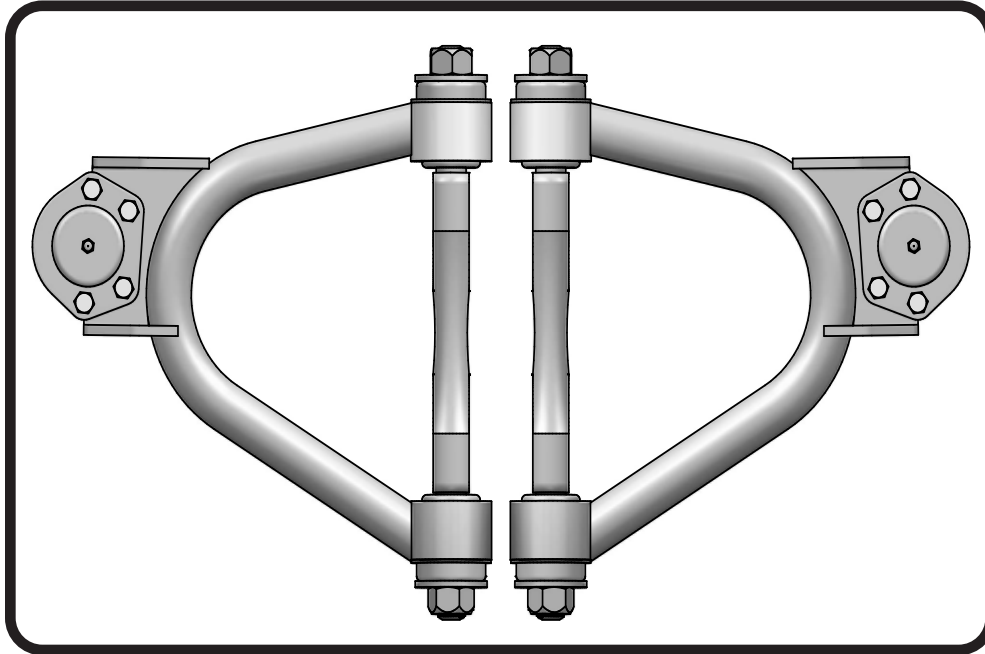

C-10 CoolRide Upper StrongArms Installation Instructions

Table of contents

Page 2..... Included components
Page 3..... Installation





Upper Control Arm ComponentsIn the box

Item #	Part Number	Description	QTY
1	90000911/90000902/90000910	(63-70/71-72/73-87) - Upper Balljoint Assembly	2
2	90003150	Driver Upper Control Arm (Shown)	1
2	90003151	Passenger Upper Control Arm	1
3	90003154	Upper Control Arm Shaft	2
4	70010759	Control Arm Bushing - 2.0" OD Ledge	4
5	70010827	Control Arm Bushing - 1.75" OD Ledge	2
6	70010826	Control Arm Bushing - No Ledge	2
7	90002737	Aluminum Control Arm Bushing Washer	4
8	99622005	5/8"-18 Top Lock Nut	4

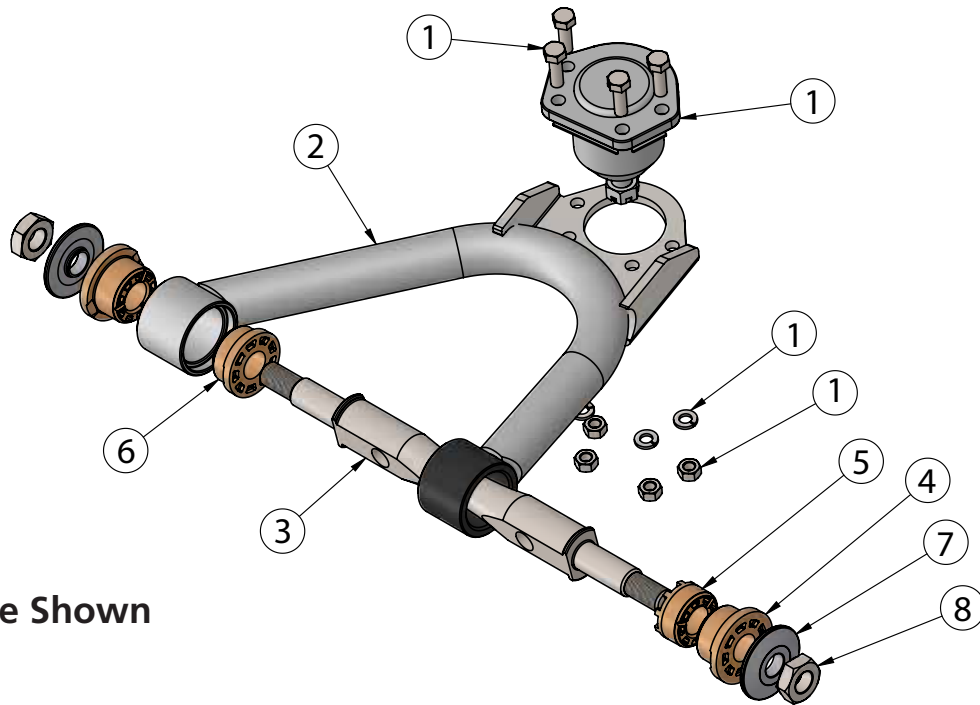

Driver Side Shown

Getting Started.....

Note: The 63-87 C-10's have similar control arms through the years, but the balljoints used were different. The year breaks are as follows: 63-70, 71-72, 73-87. Be sure to use the correct balljoint for the year of spindle you are using.

Balljoints:

- | | | |
|---------------|----------------|----------------|
| 63-70: | Upper-90000911 | Lower-90000912 |
| 71-72: | Upper-90000902 | Lower-90000909 |
| 73-87: | Upper-90000910 | Lower-90000909 |



Installation

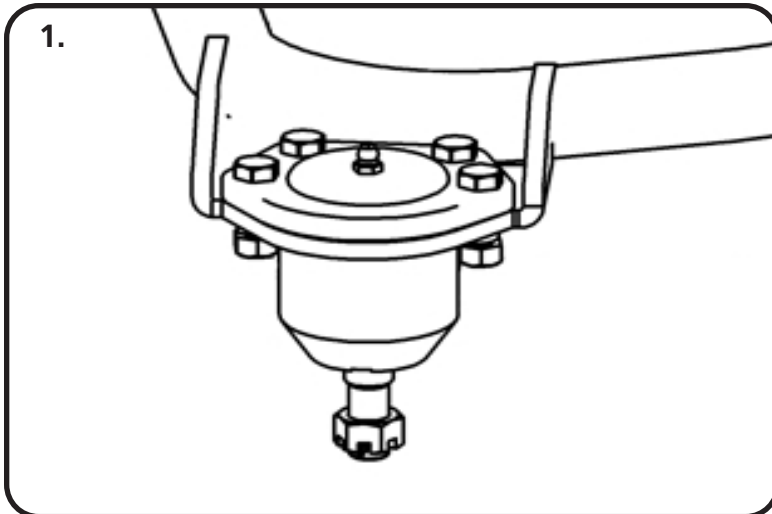

1. Install the balljoints into the upper control arm with the hardware supplied with the balljoint. The upper balljoint goes in from the top side of the control arm. The gussets on the balljoint plate point up. Torque the hardware to 20 ftlbs.

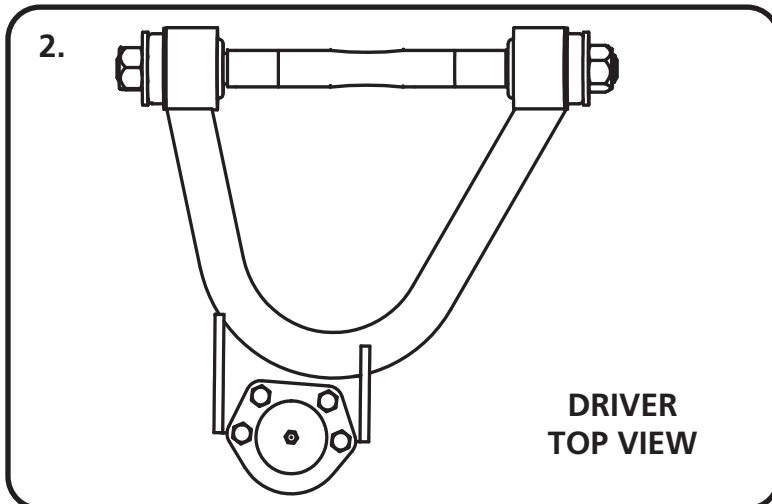

2. Diagram "2" shows the Driver Upper Control Arm. This is looking at the control arm from the top.



3. Remove the OEM upper control arms from the truck. Fasten the control arms to frame using the stock hardware. Reuse the alignment shims; however the truck must be realigned after installation. Torque the nuts to 70 ft-lbs. The upper cross shaft nuts can be torques to 55 ft-lbs.

4. Grease the upper balljoints.