



Part # **11340301**⁽⁶³⁻⁷⁰⁾/**113520301**⁽⁷¹⁻⁷²⁾ - C10 CoilOver System

Front Components:

11342699/11352699	Front StrongArm System
11349300/11359300	Front Spindles and Caliper Brackets
11333511	Front Coilovers
11369100	Front MuscleBar

Rear Components:

11337199	Rear StrongArm System
11336511	Rear Coilover Instructions

Miscellaneous Components:

85000000	Spanner Wrench
----------	----------------

Recommended Tools

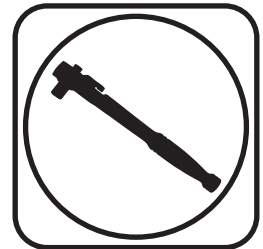

63-70/71-72 C-10 TQ Coilover System Installation Instructions

Table of contents

Pages 2-14.....	Front StrongArm System
Pages 15-16.....	Front Coilovers
Pages 17-18.....	Spindles
Pages 19-23.....	Front MuscleBar
Pages 24-33.....	Rear StrongArm System
Pages 34-35.....	Rear CoilOver
Pages 36-37.....	Coilover Assembly and Adjustment

IF YOUR TRUCK HAS A WOODEN BED FLOOR, KIT #11337299 WILL BE REQUIRED FOR SHOCK CROSSMEMBER CLEARANCE.





Part # **11342699**⁽⁶³⁻⁷⁰⁾/**11352699**⁽⁷¹⁻⁷²⁾ - C10 StrongArms

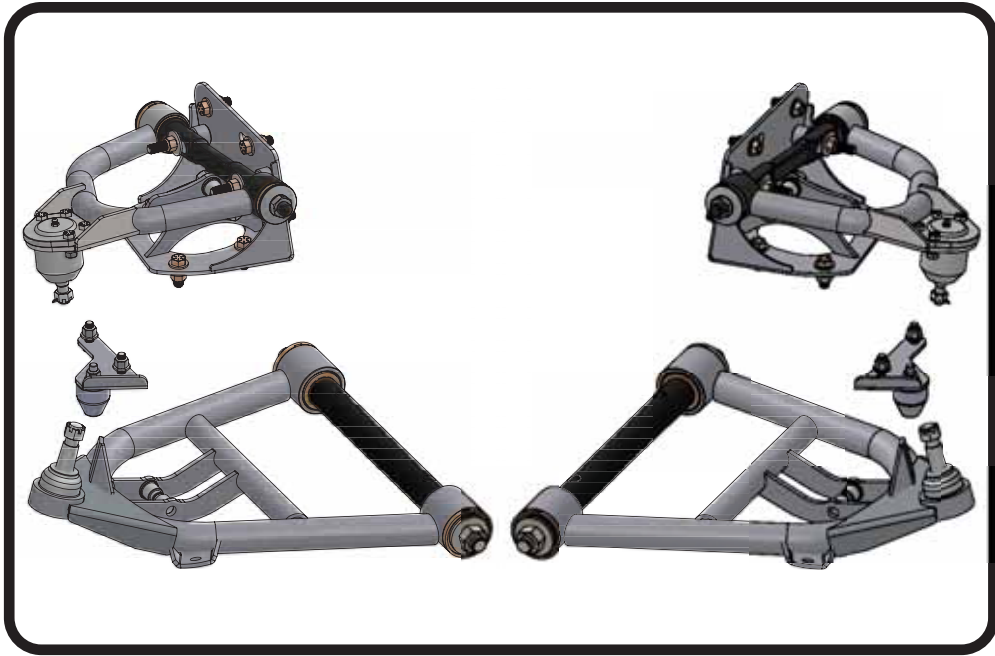

Recommended Tools

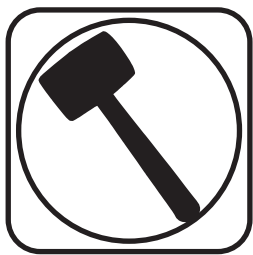
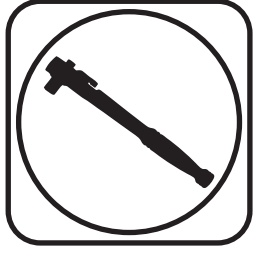

1963-1972 C-10 StrongArms Installation Instructions

Table of contents	
Page 3.....	Component Assemblies
Page 4.....	Lower Control Arm Components
Page 5.....	Upper Control Arm Components
Page 6.....	Hardware List and Getting Started
Page 7.....	Installing Upper Control Arm Mount
Page 8.....	Installing Upper Control Arm Mount and Upper Arm
Page 9.....	Caster Explained
Page 10.....	Offset Upper Cross Shaft
Page 11.....	Installing Upper and Lower Control Arm
Page 12.....	Installing CoilOver Assembly
Page 13.....	Finishing and Alignment
Page 14.....	Crossmember Trimming Template



Major Components AssembledIn the box

DRIVER UPPER CONTROL ARM ASSEMBLY

Exploded View on Page 5

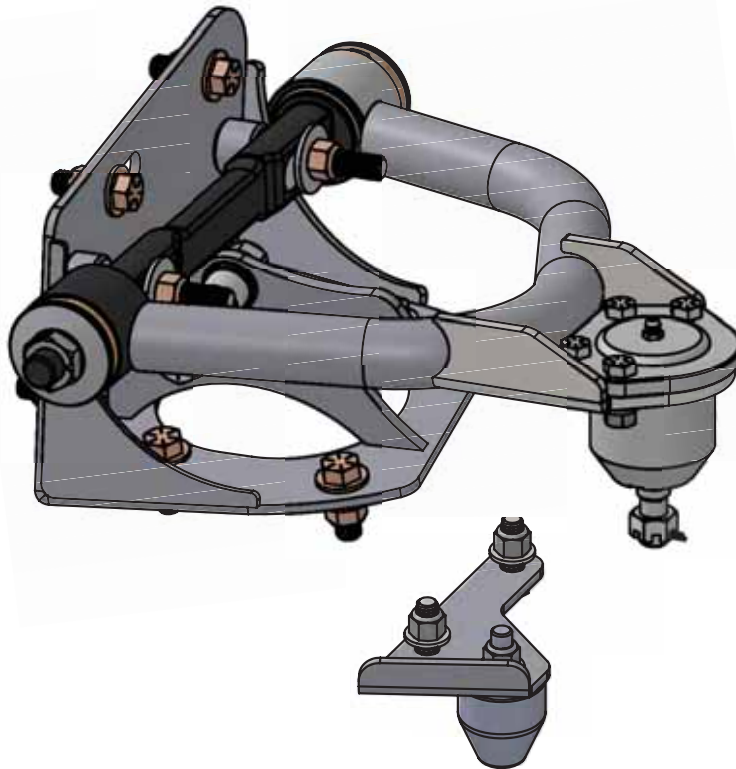

DRIVER LOWER CONTROL ARM ASSEMBLY

Exploded View on Page 4

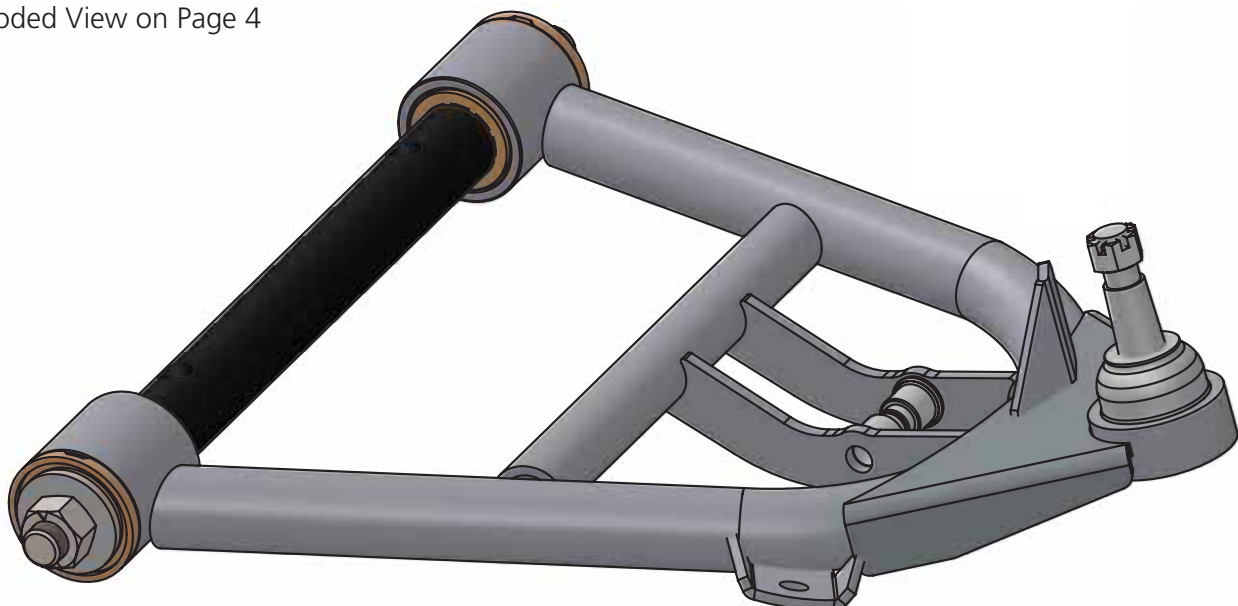



Lower Control Arm ComponentsIn the box

Item #	Part Number	Description	QTY
1	90002384	Driver Lower Control Arm (Shown)	1
1	90002385	Passenger Lower Control Arm	1
2	90002430	Lower Control Arm Cross Shaft	2
3	90000912/90000909	(63-70/71-87) - Lower Ball Joint Assembly	2
4	99753001	Flat Washer - included in hardware kit	4
5	99752005	3/4"-16 Hex Nut - included in hardware kit	4
6	70010755	Outer Delrin Bushing - with Ledge	4
7	70011465	Inner Delrin Bushing - no Ledge	4
8	90002062	Shock Bearing Spacers	4

Driver Side Shown

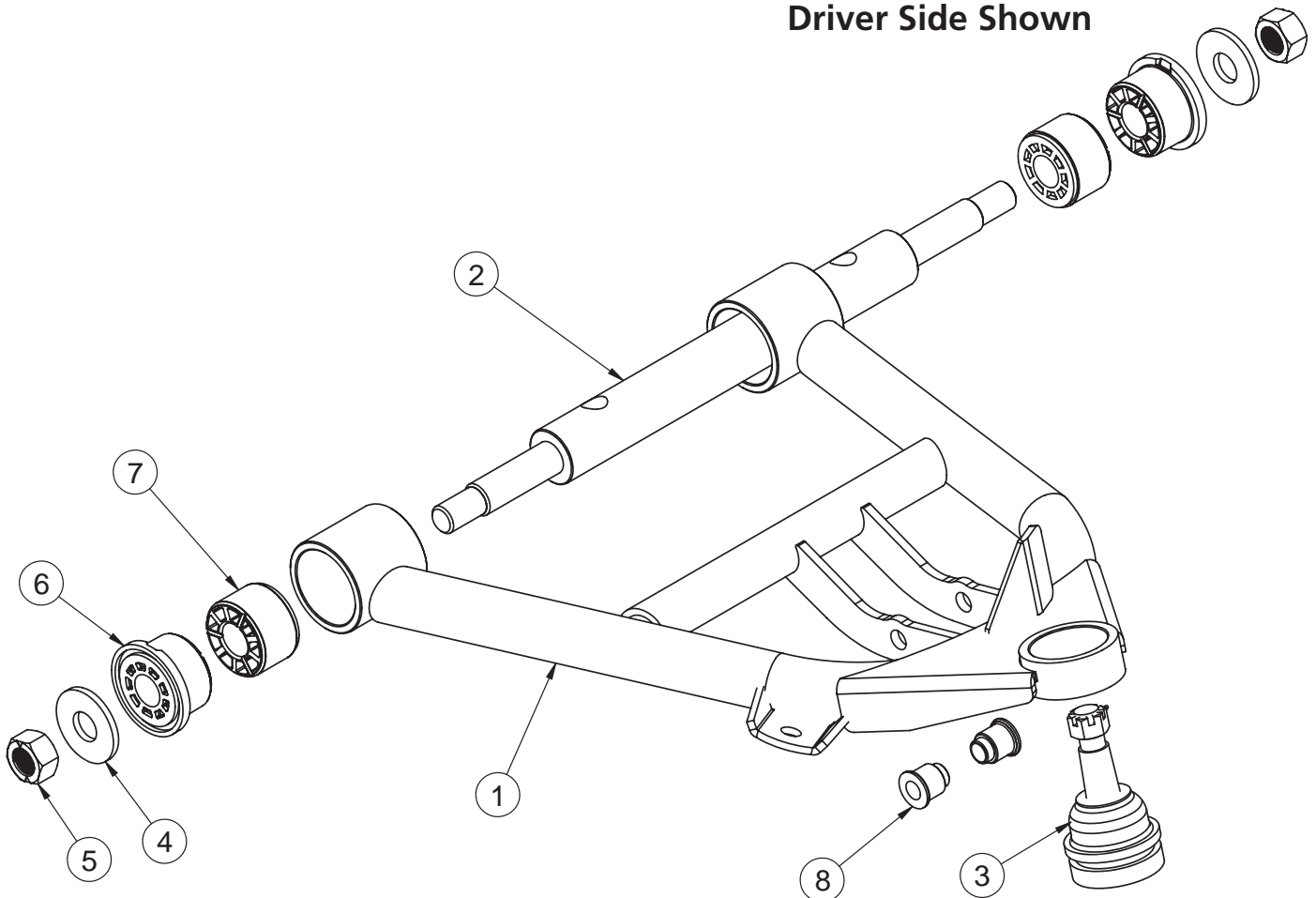



Upper Control Arm ComponentsIn the box

Item #	Part Number	Description	QTY
8	90002062	Shock Bearing Spacers	4
9	90002437	Driver Upper Control Arm (Shown)	1
9	90002438	Passenger Upper Control Arm	1
10	90003375	Caster Adjustable Upper Control Arm Shaft	2
11	70010759	Outer Delrin Bushing	4
12	70010827	Inner Delrin Bushing - with Ledge	2
13	70010826	Inner Delrin Bushing - No Ledge	2
14	90003933	WASHER; 1.45OD	2
15	90003934	WASHER; 1.70OD	2
16	90002737	Delrin Bushing T-Washer	4
17	99622005	5/8 - 18 Locknut (included with 90000914)	4
18	70010882	Caster Slug	4
19	90000911 Kit/90000902 Kit/90000910 Kit	(63-70/71-72/73-87) - Upper Ball Joint Assembly	2
20	90002386	Driver Upper Control Arm Mount	1
20	90002387	Passenger Upper Control Arm Mount (Not Shown)	1
21	90000726	Driver Bumpstop Plate	1
21	90000727	Passenger Bumpstop Plate (Not Shown)	1
22	70013323	Bumpstop	2

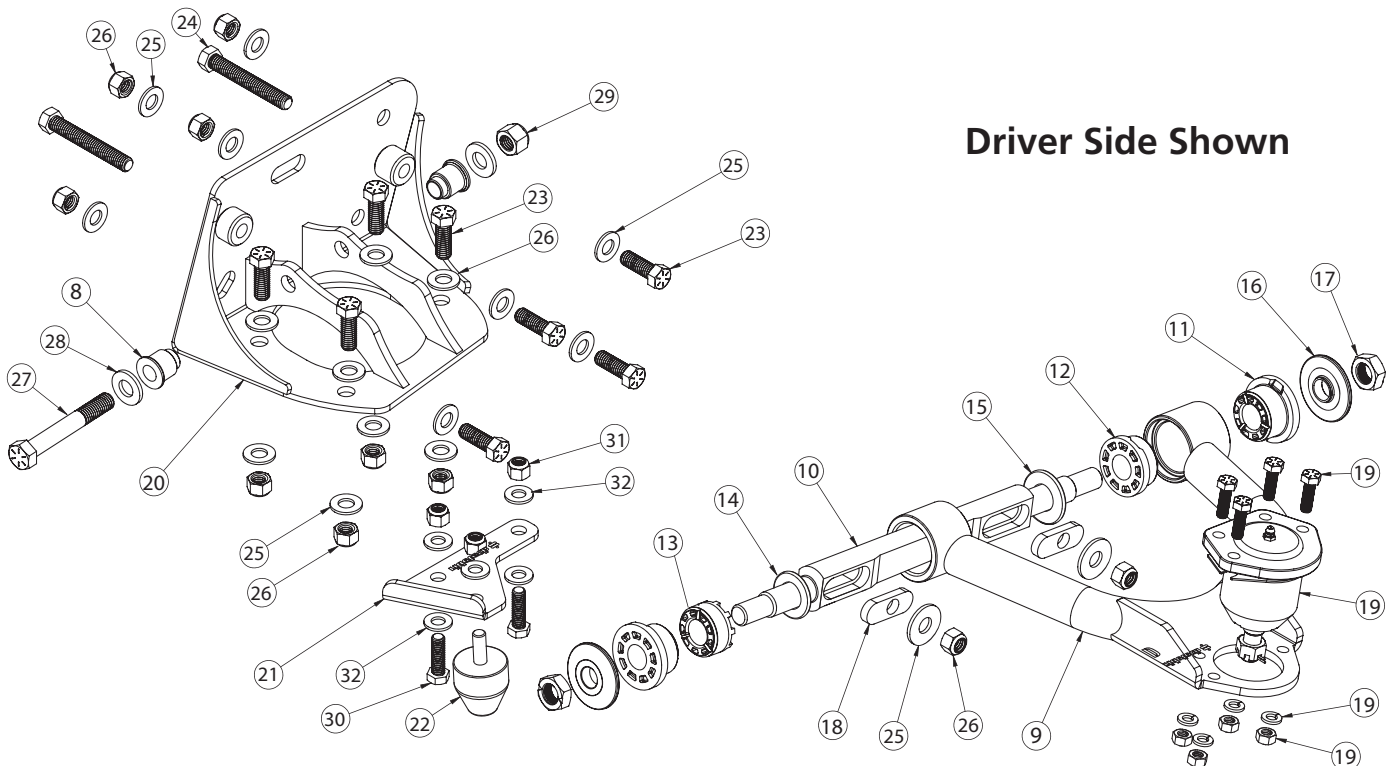



Hardware ListIn the box Kit #99010079

Item #	Part Number	Description		QTY
21	99431002	7/16"-14x1 1/4" Hex Bolt	Upper Control Arm Mount	16
22	99431003	7/16"-14x3" Hex Bolt	Upper Control Arm to Mount	4
23	99433002	7/16" Flat Washer	Upper Mount to Frame/Control Arm to Mount	20
24	99432001	7/16"-14 Nylok Nut	Upper Mount to Frame/Control Arm to Mount	20
25	99501024	1/2"-13x3 1/2" Hex Bolt	Coilover to Arm and Upper Mount	4
26	99503014	1/2" SAE Flat Washer	Coilover to Arm and Upper Mount	8
27	99502001	1/2"-13 Nylok Nut	Coilover to Arm and Upper Mount	4
28	99371006	3/8"-16x1 1/2" Hex Bolt	Bumpstop Mount to Frame	4
29	99372002	3/8"-16 Nylok Nut	Bumpstop & Bumpstop Mount to Frame	6
30	99373003	3/8" SAE Flat Washer	Bumpstop & Bumpstop Mount to Frame	10

Getting Started.....

Congratulations on your purchase of the Ridetech StrongArm System. These arms have been designed to give your truck excellent handling along with a lifetime of enjoyment. Some of the key features of these StrongArms: Ball joint angles have been optimized for the lowered ride height, Delrin bushings are used for no bushing deflection along with providing free suspension movement through the entire travel. The Delrin bushings are made from a material that is self lubricating so no grease zerks are needed. Upper caster adjustable cross shaft is designed to allow you to run maximum caster angles with minimal shims.

Note: These control arms are designed for use with the Ridetech CoilOvers and the MuscleBar swaybar. **The factory shocks and springs or the factory sway bar will not fit these arms.**

Note: The arms in this kit are designed to be used with 63-87 C-10 Spindles. The 63-87 C-10's have similar control arms through the years, but the ball joints used were different. The year breaks are as follows: 63-70, 71-72, & 73-87. Be sure to use the correct ball joint for the year of spindle you are using.

Balljoints:	Ridetech#	Proforged#	Ridetech#	Proforged#
63-70:	Upper-90000911	101-10037	Lower-90000912	101-10036
71-72:	Upper-90000902	101-10044	Lower-90000909	101-10040
73-87:	Upper-90000910	101-10046	Lower-90000909	101-10040

Installation

1. Remove the entire front suspension from the truck leaving the tie rods connected to the center draglink. Refer to the factory service manual for disassembly procedure. Your original spindle will be reused with this setup, set them to the side for the time being. The original U-bolts for the lower control arms will be reused to fasten your new StrongArms to the frame.



Installing Upper Control Arm Mount



2. The factory upper control arm mount will need to be removed from the frame. There are 4 bolts attaching it to the frame rail with 4 rivets attaching it to the crossmember. There are several methods that can be used to remove the rivets from the crossmember. One way is to cut a "+" in the head of the rivet and chisel the 4 pieces of the head off the rivet, then knock the rivet out of the frame with a hammer and punch.



3. The top side of the crossmember will also need trimmed for CoilOver clearance. **A TEMPLATE IS PROVIDED ON PAGE 13.** Cut out the holes in the template and place on top of the crossmember. Trace the template onto the crossmember and cut out the center portion. The Template is a guide to the minimum amount that needs to be cut out. Due to variations in the crossmembers, you may need to trim more to get the upper mount to sit flat on top of the crossmember.



4. Before installing the mount, install the 7/16" x 3" bolts into the upper mount from the back side with the threads pointing towards the wheel side of the bracket. Set the upper control arm mount into position on the frame. The upper brackets are marked D & P for driver & passenger. The brackets get bolted to the frame with 7/16" x 1 1/4" hex bolts and Nylok nuts. The bracket also gets a 7/16" washer under the bolt and under the nut. Due to variances in the frames it may be necessary to drill out the front lower hole. Torque the 7/16" hardware to 50 ftlbs.



Installing Upper Control Arm Mount and Control Arm

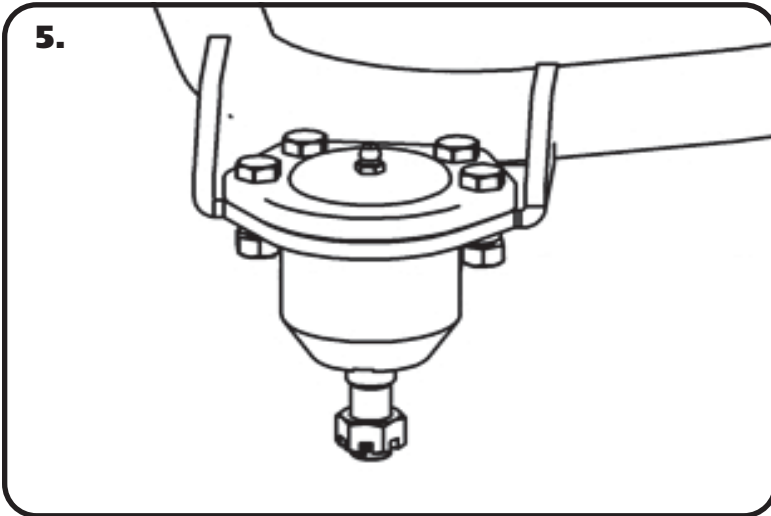

5. Install the ball joints into the upper control arm with the hardware supplied with the ball joint. The upper ball joint goes in from the top side of the control arm. The gussets on the ball joint plate point up. Torque the mounting hardware to 20 ftlbs.

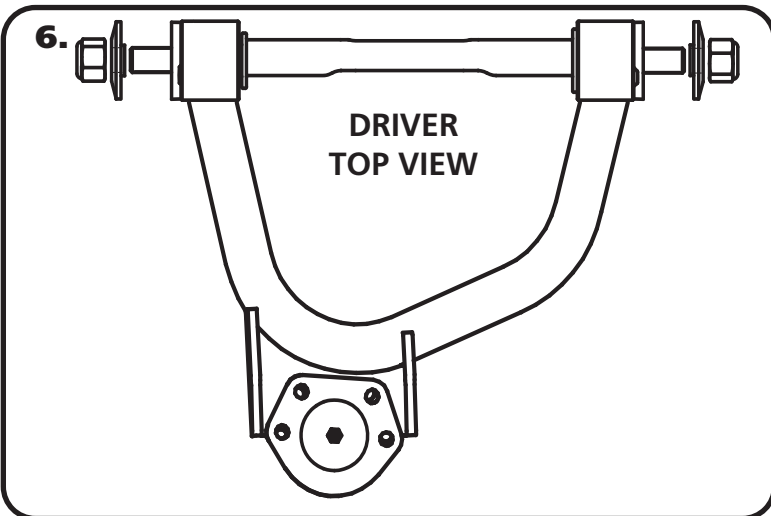

6. The driver side arm is shown in **Figure "6"**. The Ball Joint located on the arm to the front of the truck. Install the T-Washers and 5/8"-18 Lock Nuts using **Figure "6"** as a reference. These can be tightened after installing the control arms on the truck.

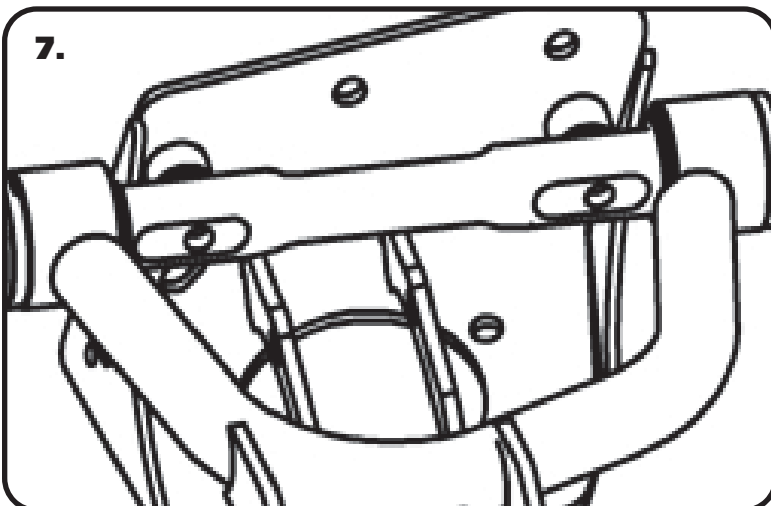

7. Install the caster slugs into the cross shaft. The long side of the caster slug goes to the **rear** of the truck. Use the diagram on the next page as a reference for installing the caster slugs. The cross shaft is attached to the truck using a 7/16" USS Flat Washer & 7/16" Nylok Nut. The drivers side is shown in **Figure "8"**. Now tighten the 5/18"-18 locknuts on the cross shaft. This nut gets snugged up. You want the suspension to be able to move freely.



Caster Explained

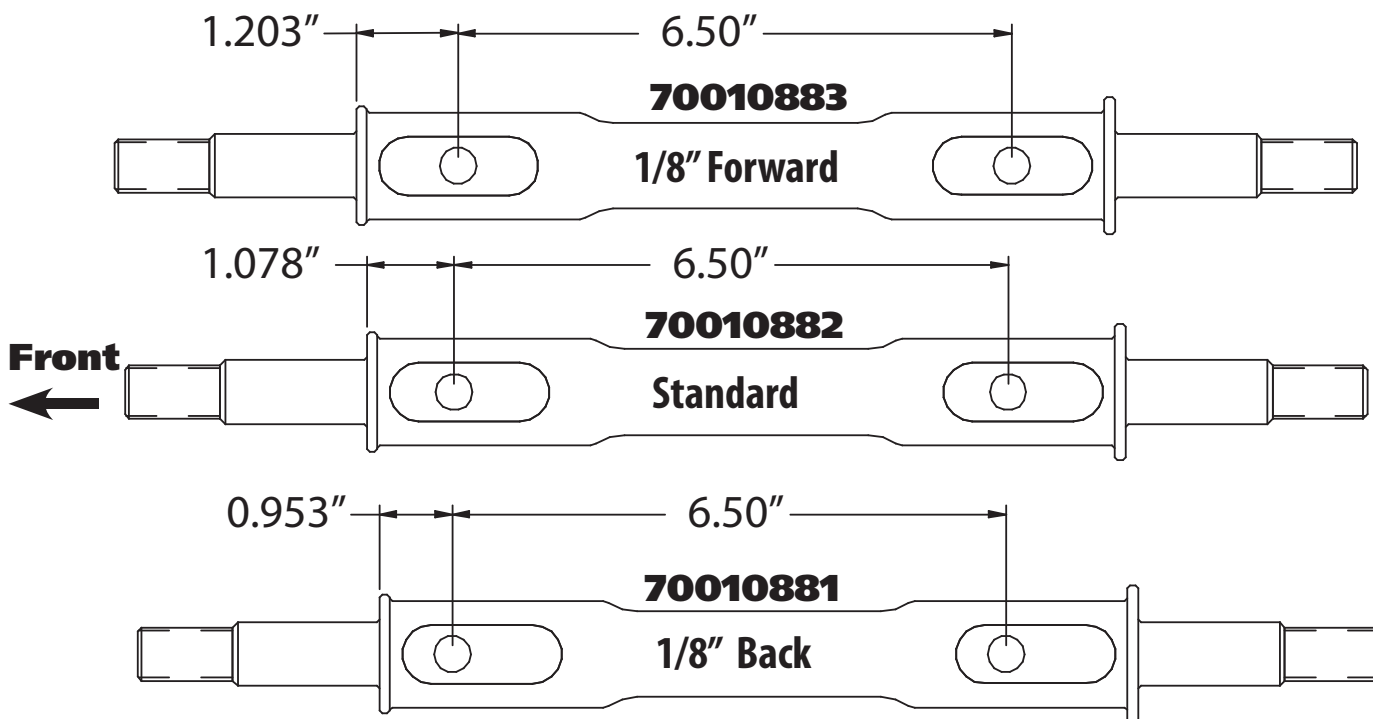

These StrongArms come equipped with a changeable caster slug setup. This allows you to add or remove caster from the front suspension, if desired. The caster slugs that come supplied in the kit are standard (70010882). The caster slugs allow you to add or remove caster without having to use a stack of shims. If more or less caster is desired, optional slugs can be purchased from Ridetech or your Ridetech dealer.

1/8" Forward = 70010883

1/8" Back = 70010881

Caster Explained:

To understand caster you need to picture an imaginary line that runs through the upper ball Joint and extends through the lower ball Joint. From the side view the imaginary line will tilt forward or backward. The tilting of this imaginary line is defined as caster.

Caster is measured in degrees by using a caster gauge. If the imaginary line described above tilts towards the back of the vehicle at the top, then you have positive caster. If the imaginary line tilts forward then you have negative caster.

Positive caster provides the directional stability in your vehicle. Too much positive caster will make the steering effort difficult. Power steering will allow you to run more positive caster. Negative caster requires less steering effort but will cause the vehicle to wander down the highway



Offset Upper Control Arm Shaft

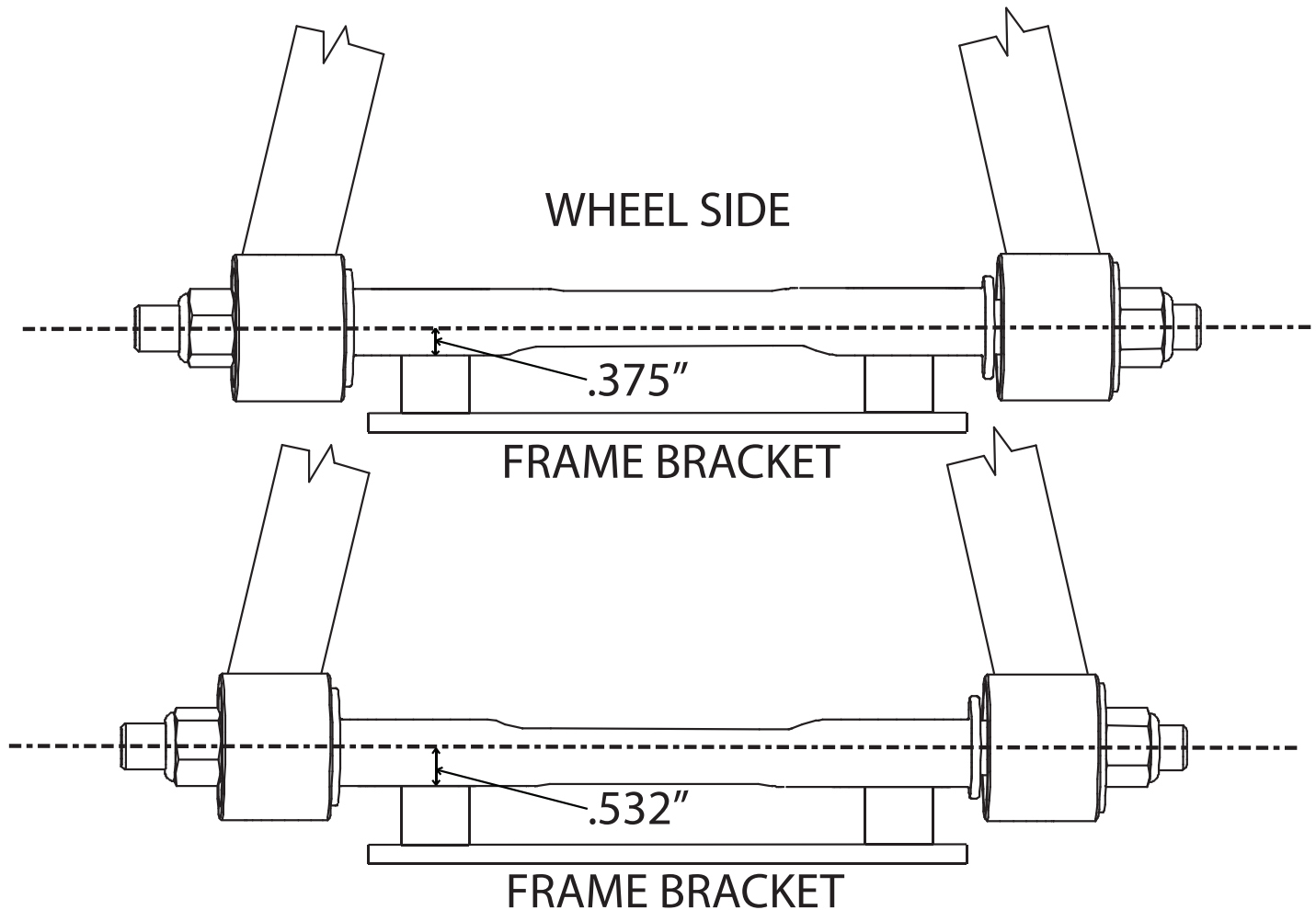

The cross shaft that is used in the upper control arms is offset. The offset combined with the caster slug option allows you to achieve the alignment setting you desire with minimal shims. To change the direction the Icon faces simply spin the cross shaft in the control arm.

If you are after a **Street Alignment** bolt the upper control arm to the frame mount with the arm offset to the outside of the truck. The Ridetech Icon will be facing the wheel.

If a more aggressive **Track or Autocross** alignment is desired, bolt the control arm to the frame bracket with the arm offset to the inside of the truck. The Ridetech Icon will be facing the frame rail.



Installing Upper and Lower Control Arm



8. The lower control arm is installed using the factory u-bolts and nuts. The lower control arm is located by a pin that is in the center of the front u-bolt cradle. This pin will go into the hole in the control arm shaft to help locate the control arm. Bolt the control arm to the frame with the sway bar tab to the front of the truck.

NOTE: We have encountered some trucks where the rear pin is the locator pin. It will locate the control arm correctly too.

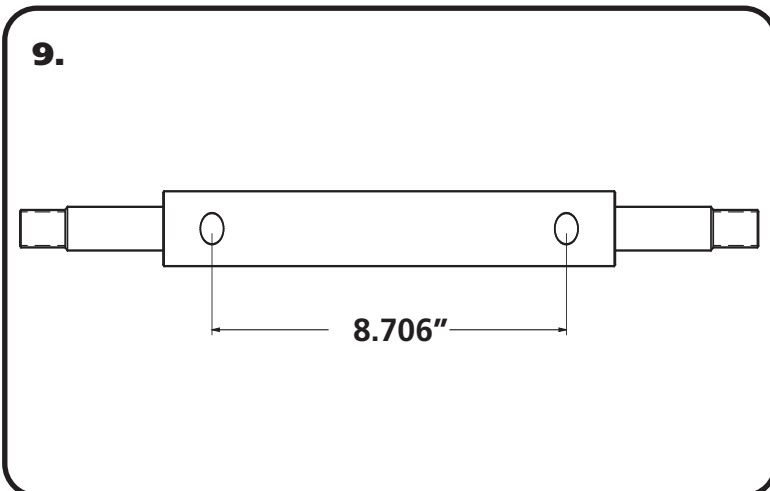

9. The Lower Cross Shaft has 2 different locating hole patterns. These StrongArms use the 8.706" center to center locating holes. The Pin in the Cross Shaft Saddle that was pointed out in **Image 8**, will locate into these Holes. Use the OEM Hardware to attach the Lower making sure the Locating Pin is in the 8.706" center to center Holes.



10. **Image 10** is an example of the lower control arm bolted to the crossmember. Install 3/4" ID Washer on to each end of the cross shaft against the bushing. Then install the 3/4"-16 lock nut. Snug the nut up against the washer. You want the suspension to move freely through its travel.



Installing CoilOver Assembly

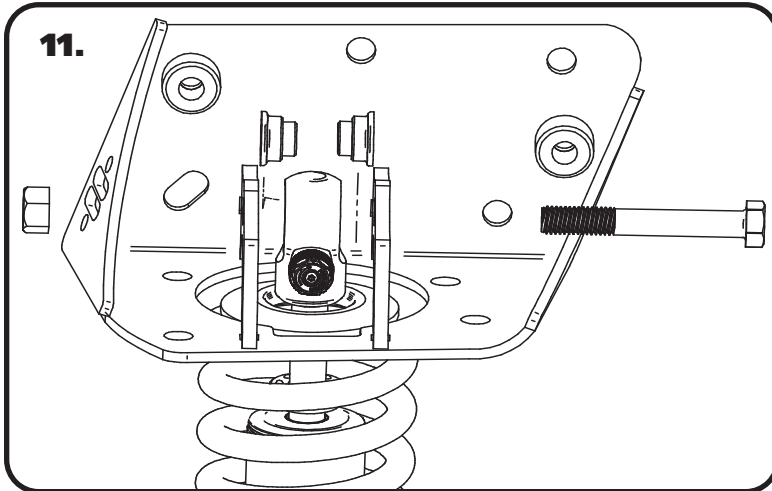

11. Install a spacer on each side of the upper Coilover. The small outside diameter of the spacer will insert into the shock bearing. Push the spacer in until it bottoms out in the bearing. Slide the assembly into the upper mount from the bottom side. If your shock has an adjuster knob position it to the wheel side of the mount. Line up the hole in the spacers with the hole in the strap and insert 1/2" x 3 1/2" bolt and install 1/2" Nylok nut.

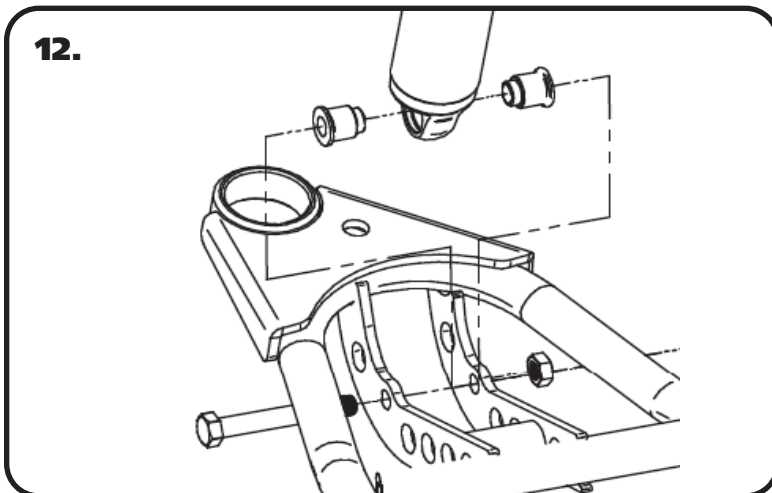

12. Install a spacer on each side of the lower Coilover. The small outside diameter of the spacer will insert into the shock bearing. Push the spacer in until it bottoms out in the bearing. Slide the shock with the spacers installed into the lower control arm. Raise the arm up to line up the holes in the bushing with the 1/2" hole in the control arm straps and hold it in place while you install the 1/2" x 3 1/2" bolt and 1/2" Nylok nut. Tighten the upper and lower shock bolts to 75 ftlbs.



13. Depending on your wheel size, you may need an external bumpstop to keep the tire from hitting the inner fender. The bump stop plate attaches to the wheel side of the crossmember. The bent tab goes against the back side of the crossmember with the holes as far out as you can drill them. Use the mount as a template to drill the holes and attach mount with the remaining 3/8 x 1 1/2" bolts washers and Nylok. After mounting the plate, you can attach the bumpstop. Torque the 3/8" hardware to 30 ftlbs.



Finishing & Alignment

14. The final step is to reinstall the spindle onto the truck. Slide the ball joint pins into the spindle and install the castle nut on each one. Torque the ball joint nuts and install cotter pins in each one.

Ball Joint nut Torque Specs:

Upper: Torque to 50 ftlbs and then tighten nut to align cotter pin hole not exceeding 90 ftlbs.

Lower: Torque to 90 ftlbs and then tighten nut to align cotter pin hole not to exceeding 130 ftlbs.

Suggested Alignment Specs:

Camber: Street: -.5 degrees

Caster: Street: +3.0 to + 5.0 degrees

Toe: Street: 1/16" to 1/8" toe in

UPPER CROSSMEMBER TRIMMING TEMPLATE FOR COILOVER

DRIVER

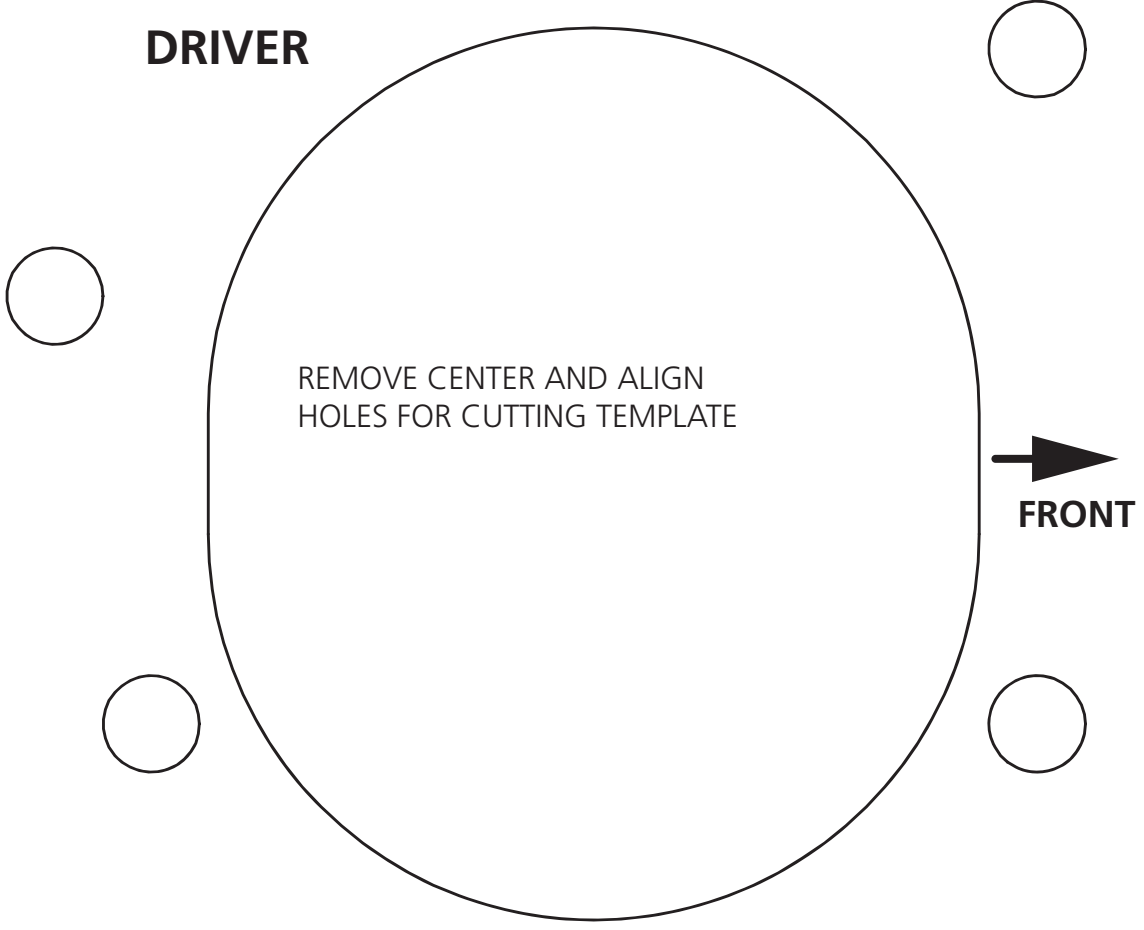

REMOVE CENTER AND ALIGN
HOLES FOR CUTTING TEMPLATE

FRONT

PASSENGER

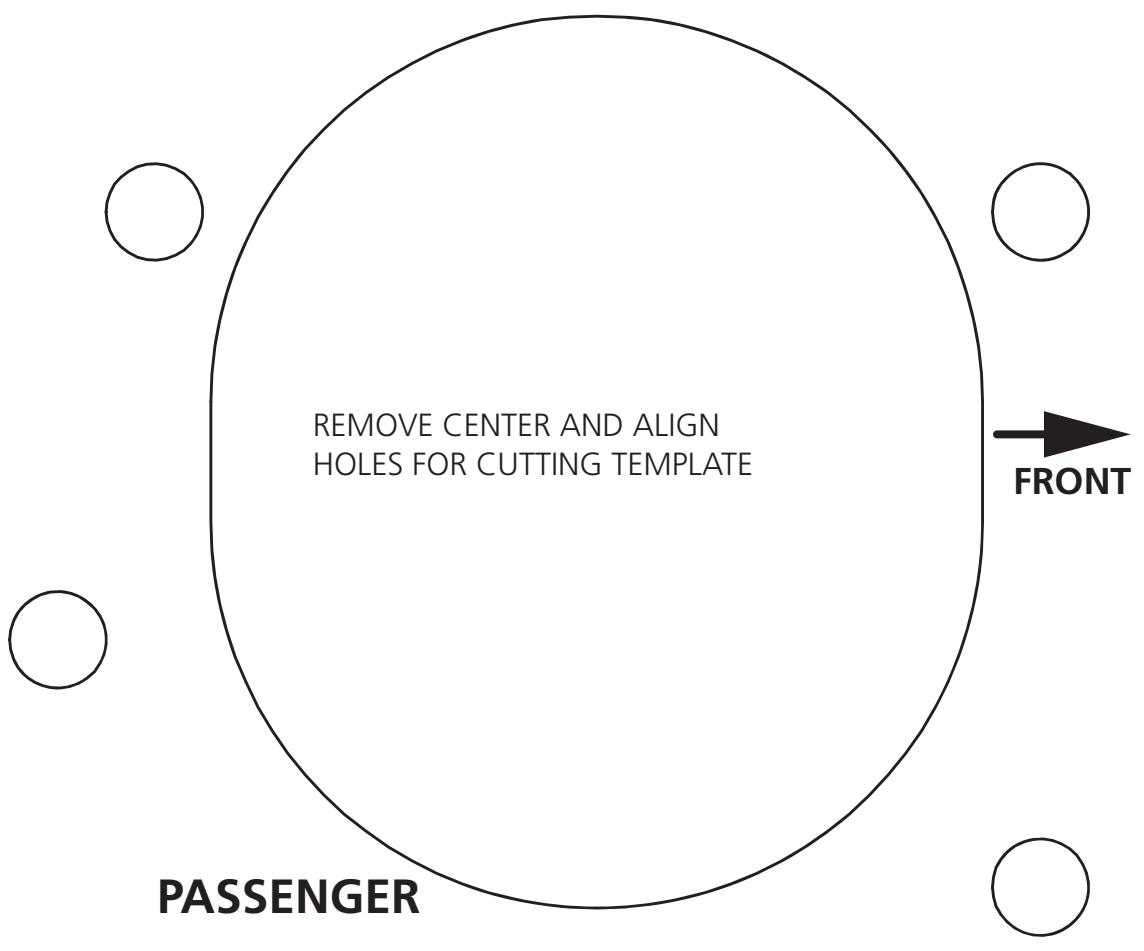

REMOVE CENTER AND ALIGN
HOLES FOR CUTTING TEMPLATE

FRONT



Part # 1133511 - 1963-1972 C10 Front CoilOvers

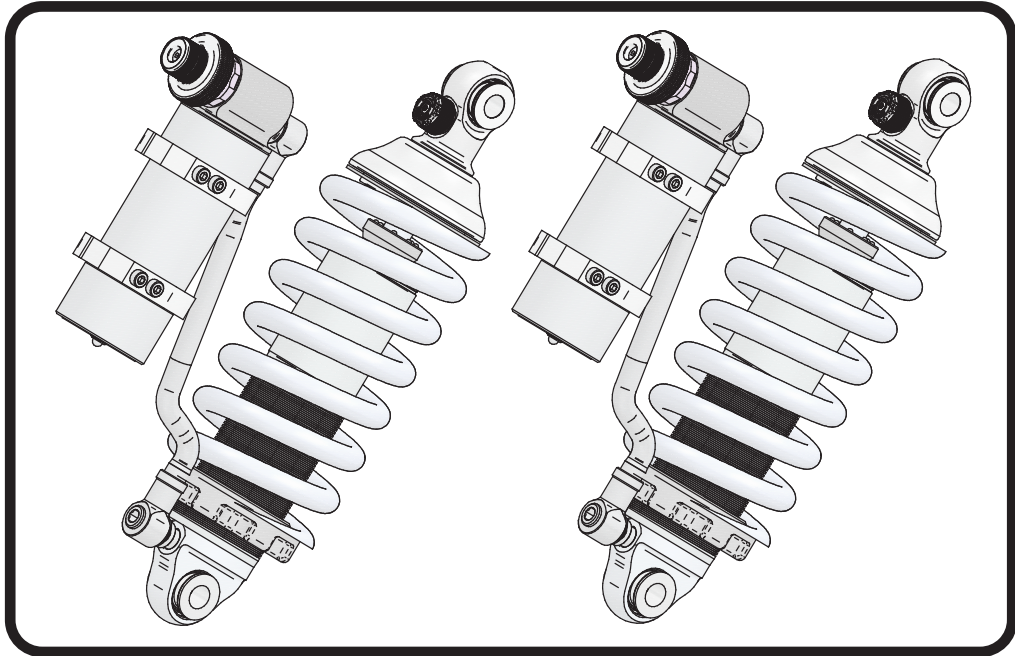

Recommended Tools



1963-1972 C-10 TQ Series Front Coilovers Installation Instructions

Table of contents
Page 16..... Included Components



Major ComponentsIn the box

Item #	Part #	Description	QTY
1	986-10-070	3.6" Stroke TQ Series Shock	2
2	815-05-022-KIT	1.7" Shock Eyelet	2
3	90002070	Dropped Coilspring Cap	2
4	59070750	Coilspring 7" 750lb	2
5	70010828	Delrin Spring Washer	4
6	803-00-199(kit)	Lower Spring Adjuster Nut (803-00-199 kit)	2
	803-00-199(kit)	Adjuster Nut Locking Screw (803-00-199 kit)	2
	803-00-199(kit)	Retaining Ring (803-00-199 kit)	2
9	026-05-000	Reservoir Clamps	4
10	99050000	Reservoir Socket Head Cap Screws	12
11	90001994	5/8" ID Bearing (installed in shock and eyelet)	4
12	90001995	Bearing Snap Ring (installed in shock and eyelet)	8

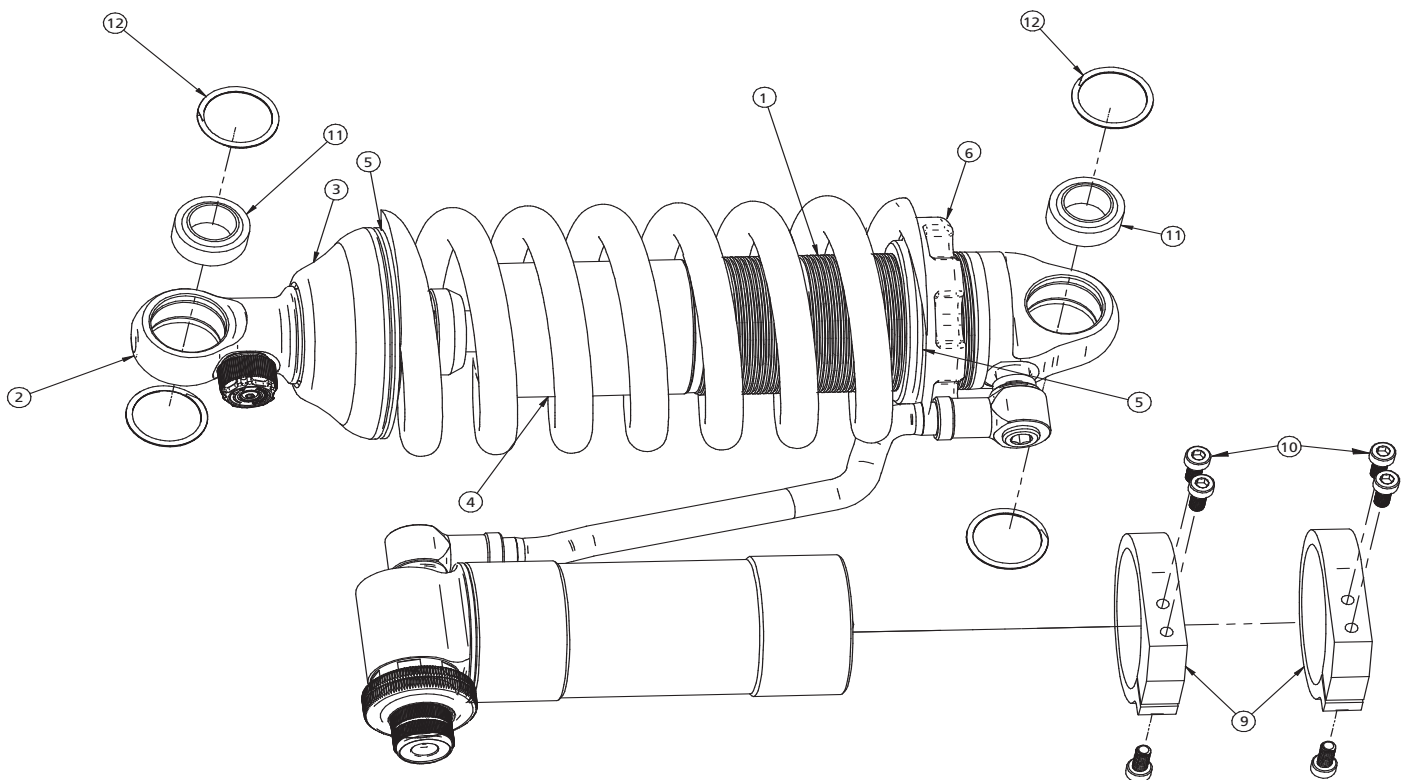

BEARING SPACERS (90002062) ARE INCLUDED WITH THE FRONT CONTROL ARMS.



Part # 11349300⁽⁶³⁻⁷⁰⁾/11359300⁽⁷¹⁻⁷²⁾ - C10 Drop Spindles



Recommended Tools

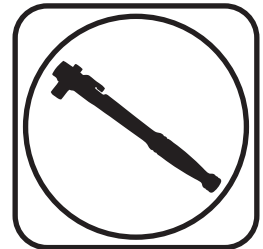

Major ComponentsIn the box

1	11349301/11359301	Pair of drop spindles
1	90001926	Pair of caliper brackets

Installation

Balljoint nut Torque Specs:

Upper: Torque to 50 ft lbs and then tighten nut to align cotter pin hole not exceeding 90ft lbs.

Lower: Torque to 90 ft lbs and then tighten nut to align cotter pin hole not to exceeding 130 ft lbs.

Note: These spindles are setup for 1973-1987 HD Rotor and Caliper. The HD Rotor is 1 1/4" wide.



Spindle Installation

Notes:

This spindle will not work with drum brakes.

A 7/16-14 bolt can be threaded into the spindle and used as an adjustable steering stop.

Instructions:

1. Remove the outer tie rods from the original spindles.
2. Trucks that are reusing existing 1973-1987 heavy half ton 1-1/4" thick rotors and calipers will need to remove the disc brake assemblies from the spindles. Trucks that are not reusing the existing brakes need to disconnect the brake hose from the brake line.
3. Remove the upper and lower ball joints from the spindle.
4. Remove the old spindles.

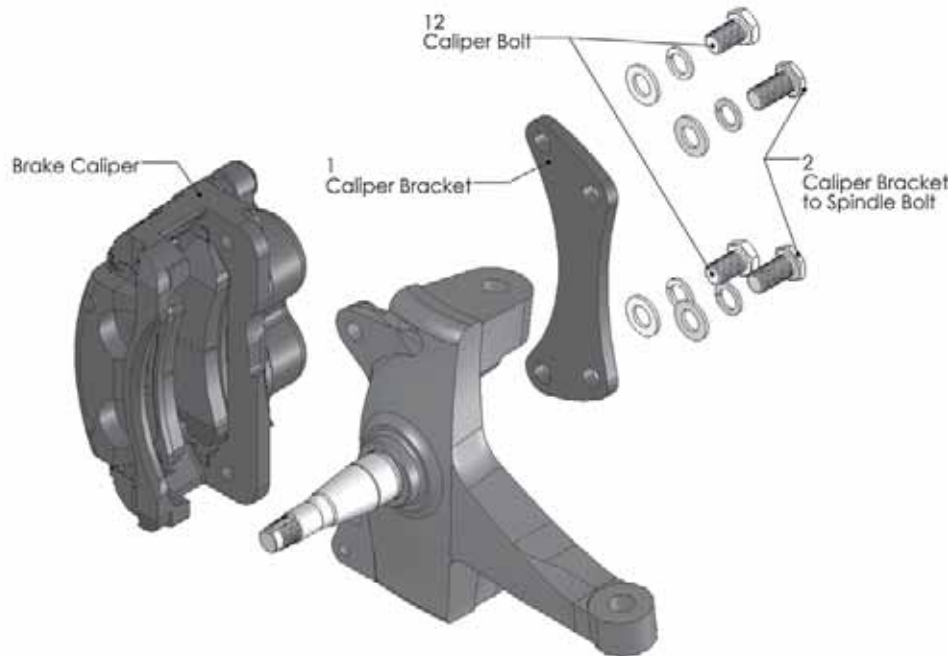

5. Install the new drop spindles onto the upper and lower ball joints.
6. Install the outer tie rods into the new spindles.
7. Install the caliper brackets. The supplied caliper brackets are designed to utilize 1973-87 heavy half ton 1-1/4" thick rotors and calipers. The brackets will mount to the inboard side of the spindle.
8. Pack the wheel bearings with grease. Install the inner bearings and the grease seal. Install the rotor/hub assembly. Install the outer wheel bearing, washer and spindle nut. Adjust the wheel bearings as follows:
 - a. Tighten the nut only slightly (no more than 12lb/ft.) spin the rotor in a forward direction to ensure the bearings are fully seated.
 - b. Check that the spindle nut is still tight. If not repeat step a.
 - c. Loosen the spindle nut until it is just loose.
 - d. Hand tighten the spindle nut and install the cotter pin. Do not use a wrench! If necessary loosen the nut too the first position the cotter pin can be installed into.
9. Install the caliper assemblies. The bleed screws will be towards the top.
10. If using new calipers connect the brake hose to the calipers and the frame. Bleed the brakes. Check for leaks.
11. Check that the rotor can turn freely and that the brakes do not drag.
12. Have the truck professionally aligned.



Part # 11369120 - 1963-1987 C10 Front Sway Bar



Recommended Tools

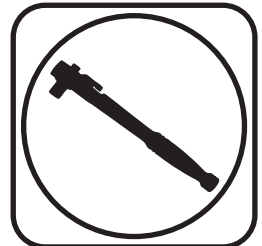

1963-1987 C-10 Front Sway Bar Installation Instructions

Table of contents	
Page 20.....	Included Components and Hardware List
Page 21.....	Sway Bar Installation
Page 22.....	Sway Bar Installation
Page 23.....	Sway Bar Installation

Hardware Torque Specifications	
3/8"-16.....	30 ftlbs

Major ComponentsIn the box

Part #	Description	QTY
90001246	Front Sway Bar	1
90002926	End Link Kit - SHORT - <i>Stock Control Arms</i>	1
90001346	Bushing Strap	2
70015016	Lined Sway Bar Bushing	2
90002591	Frame Mount	2
90002593	Control Arm Mounts	2
90002932	End Link Kit - LONG - <i>Ridetech Tubular Control Arms</i>	2

HARDWARE KIT.....99010089

QTY	Part #	Description	QTY	Part #	Description
FRAME MOUNT			BUSHING STRAP continued		
4	99371005	3/8"-16 x 1 1/4" Hex Bolt	4	99372001	3/8"-16 Nylok Nut
8	99373002	3/8" Flat Washer	CONTROL ARM MOUNT		
4	99372001	3/8"-16 Nylok Nut	4	99371005	3/8"-16 x 1 1/4" Hex Bolt
BUSHING STRAP			8	99373002	3/8" Flat Washer
4	99371005	3/8"-16 x 1 1/4" Hex Bolt	4	99372001	3/8"-16 Nylok Nut
8	99373002	3/8" Flat Washer			

Getting Started.....

This sway bar kit utilizes a anti-friction lining in the sway bar bushing. The lining allows the sway bar to move freely and quietly in the bushing. No lubrication is required.

This sway bar will fit 63-66, 67-72 & 73-87, but the installation varies between the 3 eras. Be sure that you are reading the instructions for the correct era of truck.

1. Jack the vehicle up to a safe working height and support with jack stands. Make sure the jack stands are stable before working under the truck.
2. If the truck is equipped with a stock swaybar, remove it.

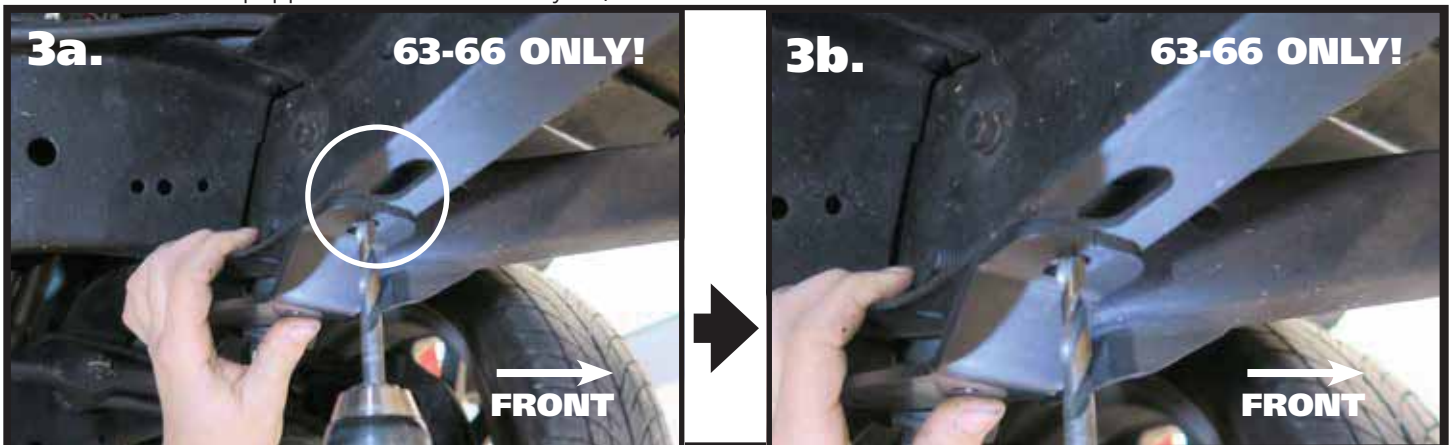

63-66 ONLY! 3a & 3b. The mounting holes for the frame mount will need to be drilled. The frame mount will attach to the frame with the ANGLED END FORWARD. The front edge of the frame mount will be aligned with the rear edge of the slot in the frame that is forward of the cross member. Hold the frame mount on the center on the frame with the front edge lined up with the rear edge of the slot. Use the frame mount as a template to mark the holes to be drilled. Drill the holes using a 3/8" drill bit. Attach the bracket using a 3/8"-16 x 1 1/4" bolt, 3/8"-16 nylok nut and a 3/8" flat washer on top and bottom. The same hardware setup is used in each hole. Repeat on the other side and torque hardware. **SKIP TO STEP 9.**



4. Remove the rivet from the bottom of the frame rail. This can be done by cutting the rivet head off and driving it out or by drilling it out. This cross member is located in front of the suspension cross member.



5. Attach the rear hole of the frame mounting bracket to the frame using the rivet hole. The end of the frame bracket with the angled bends goes forward. Attach the bracket using a 3/8"-16 x 1 1/4" bolt, 3/8"-16 Nylok nut and a 3/8" Flat Washer on top and bottom.



6. With the rear hardware installed, line up the bracket parallel with the frame rail. Use the front hole as a guide to drill a 3/8" hole in the frame.



7. Attach the front of the bracket using a 3/8"-16 x 1 1/4" bolt, 3/8"-16 Nylok nut and a 3/8" Flat Washer on top and bottom. Repeat on the other side and tighten hardware. **SKIP TO STEP 9.**



73-87 ONLY! 8a & 8b. If your truck is equipped with an OEM sway bar, the OEM mount will need to be removed to install the Ridetech sway bar. This is done by removing the rivets. The rivets can be removed by chiseling the heads off and driving them out or by drilling the rivets out. The new frame mount bolts directly in place of the old mount. If your truck doesn't have a sway bar, the mounting holes will still be in the frame. The sway bar mount attaches to the frame using the holes from the OEM mount. The end of the frame bracket with the angled bends goes forward. Attach the bracket using a 3/8"-16 x 1 1/4" bolt, 3/8"-16 nylok nut and a 3/8" flat washer on top and bottom. The same hardware setup is used in each hole. Repeat on the other side and torque hardware.



9.

9. Open the sway bar bushing at the split and slide it **OVER** the swasy bar. Do this for both bushings.



10.

10. Next, slip the bushing straps over the sway bar bushings.



11a.



11b.

11a & 11b. This kit requires a bracket to be installed on the control arm for the sway bar linkage. The bracket needs to be positioned with the inside edge 8 1/4" from the CONTROL ARM BUSHING and the ears pointing DOWN. Hold the end of the tape measure against the outer edge of the control arm bushing and make a mark on the control arm at 8 1/4". Hold the bracket on the control arm with the ears pointing DOWN and against the lip of the control arm. Use the bracket to mark and drill the mounting holes to 3/8". Install a 3/8" flat washer on (2) 3/8"-16 x 1 1/4" hex bolts and insert them into the holes. Install a 3/8" flat washer and 3/8"-16 nylok nut on each Bolt. Repeat on the other side and torque hardware.



12a.



12b.

12a & 12b. Hold the sway bar into position on the truck with the sway bar arms below the tie rods. Align the holes in the bushing straps with the holes in the frame brackets. Install a 3/8" flat washer on (4) 3/8"-16 x 1 1/4" hex bolts and insert them into the holes. Install a 3/8" flat washer and 3/8"-16 Nylok Nut on each bolt. Center the bar in the bushings before snugging up the hardware. Do **NOT** completely tighten the hardware. It will be left partially loose until the end links are installed.

13a & 13b. This kit includes 2 different lengths of end links. The SHORT end links are used for STOCK control arms. The LONG end links are used on STRONGARM installations.



13a. STOCK CONTROL ARMS Install the SHORT end links using **Diagram 1** as a reference. Install both end links before tightening the end link hardware. Tighten the end link barrel nut until it is flush with the end of the bolt, and then tighten it 2-3 more complete rounds.

13a. RIDETECH TUBULAR CONTROL ARMS Install the LONG end links using **Diagram 1** as a reference. Install both end links before tightening the end link hardware. Tighten the end link barrel nut until it is flush with the end of the bolt, and then tighten it 2-3 more complete rounds.

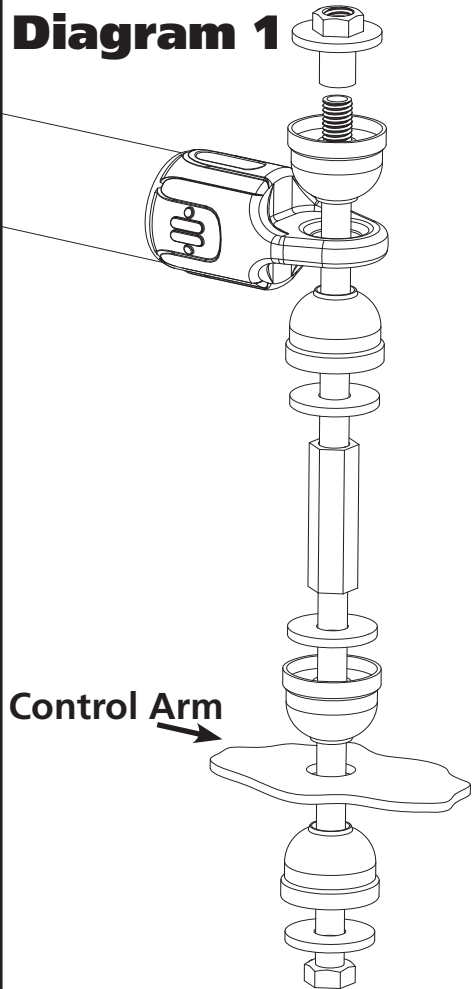

Tighten the end link barrel nut until it is flush with the end of the bolt, and then tighten it 2-3 more complete rounds.



9. Torque the sway bar mounting hardware to 30 ftlbs.



Part # 11337199 - 1963-1972 C10 Rear StrongArms

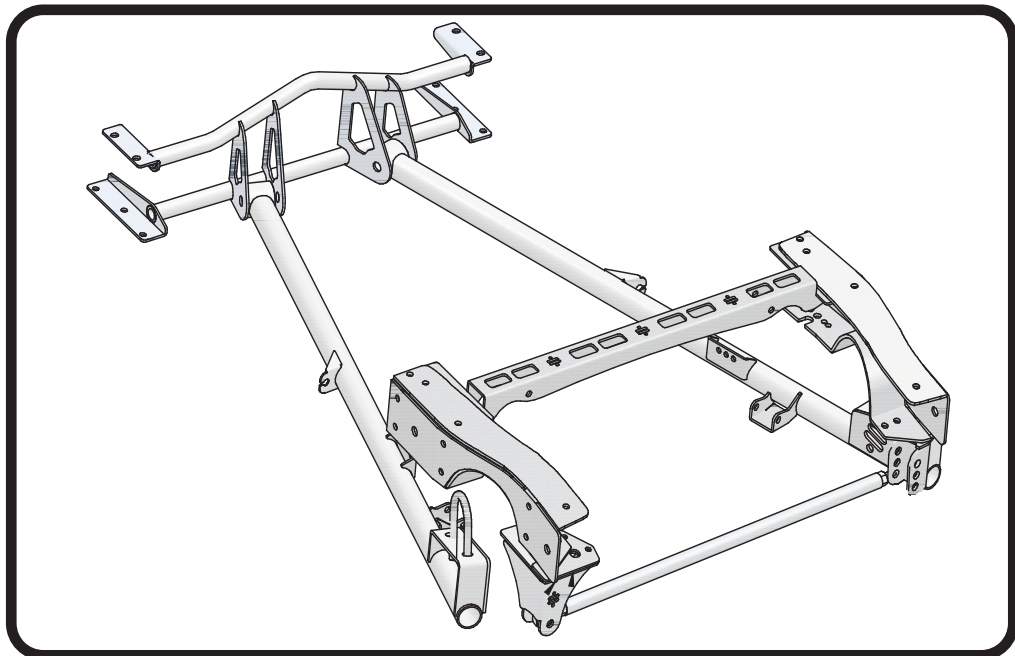

Recommended Tools

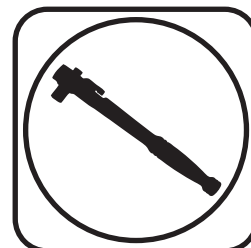

1963-1972 C-10 Rear StrongArms Installation Instructions

Table of contents

- Page 25..... Included Components
- Page 26..... Hardware List and Getting Started
- Page 27..... Disassembly and Front Crossmember Installation
- Page 28..... "C" Notch Installation
- Page 29..... "C" Notch Installation
- Page 30..... Installing "C" Notches and Shock Bridge
- Page 31..... Installing StrongArms and Panhard bar
- Page 32..... Installing Panhard bar and Shockwave/CoilOvers
- Page 33..... Finishing

IF YOUR TRUCK HAS A WOODEN BED FLOOR, KIT #11337299 WILL BE REQUIRED FOR SHOCK CROSSMEMBER CLEARANCE.

Note: This kit is designed for use with a 1-piece drive shaft. If your truck has a carrier bearing setup, it will need to be converted to a 1-piece driveshaft to eliminate the carrier bearing.



Major ComponentsIn the box

Item #	Part #	Description	QTY
1	90002435	Panhard Mount Top Spacer	1
2	99756002	Trailing Arm U-bolt	2
3	90000626	Driver Side StrongArm	1
4	90000631	Front StrongArm Crossmember	1
5	90002436	Panhard Bar Frame Mount	1
6	90002434	Panhard Mount Bottom Spacer	1
7	70013364	Panhard Bar R-Joint End	1
8	90000627	Passenger Side StrongArm	1
9	90002432	Upper Shock Bridge	1
10	90000614	Passenger "C" Notch	1
10	90000613	Driver "C" Notch	1
11	90002867	Panhard Bar (34 5/8" center to center)	1
	90002062	Shockwave/Coilover Spacers (Not Shown)	8
	90001083	Medium Bumpstop - 1.5" tall (Not Shown)	2
	70013334	Panhard Bar R-Joint Spacers .625 ID x .620" Long (Not Shown)	4
	70016244	C10 R Joint End Spacer .625 ID x .870" Long	4
	70013279	Spirolox Retaining Ring (Trailing Arm & Panhard R Joint)	1
	70013280	Wavo Wave Spring (Trailing Arm & Panhard R Joint)	1
	70013276	Delrin Snap Over Bushing (Trailing Arm & Panhard R Joint)	1
	70013275	R Joint Center (Trailing Arm & Panhard R Joint)	1
	90001318	R-Joint Rod End - threaded in panhard bar	1

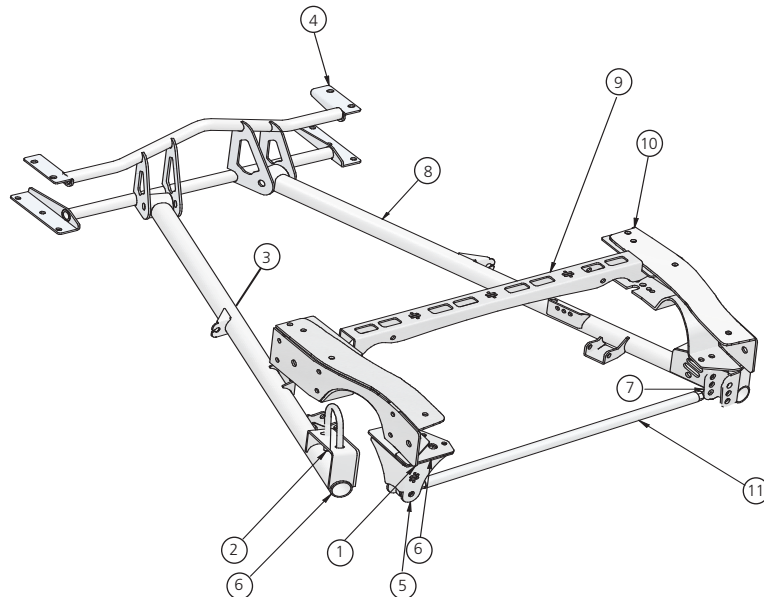



Hardware ListIn the box (Kit# 99010052)

The Hardware Kit contains bags to help aid in selecting the correct hardware for the component being installed. The hardware list shows how the hardware is bagged.

QTY	Part Number	Description	QTY	Part Number	Description
PANHARD MOUNT & PANHARD BAR			"C" NOTCH MOUNTING CONTINUED		
2	99621003	5/8" x 2 3/4" Gr. 8 Bolt	12	99622001	5/8" SAE Nylok Nut
2	99622006	5/8" SAE Nylok Jam Nut	18	99623001	5/8" SAE Flat Washer
6	99431012	7/16" x 1 3/4" USS Bolt	TRAILING ARM TO CROSSMEMBER		
6	99432001	7/16" USS Nylok Nut	2	99621015	5/8" x 4 1/2" SAE Gr.8 Bolt
12	99433002	7/16" SAE Flat Washer	2	99622001	5/8" SAE Gr. 8 Nylok Nut
FRONT CROSSMEMBER MOUNTING			4	99623001	5/8" SAE Flat Washer
10	99431001	7/16" x 1" USS Bolt	SHOCK BRIDGE & SHOCK MOUNTING		
20	99433002	7/16" SAE Flat Washer	4	99501024	1/2" x 3 1/4" USS Bolt
10	99432002	7/16" USS Nylok Nut	4	99502001	1/2" USS Nylok Nut
"C" NOTCH MOUNTING			6	99431002	7/16" x 1 1/4" USS Bolt
6	99431002	7/16" x 1 1/4" USS Bolt	6	99432001	7/16" USS Nylok Nut
12	99431001	7/16" x 1" USS Bolt	12	99433002	7/16" SAE Flat Washer
18	99432001	7/16" USS Nylok Nut	TRAILING ARM U-BOLTS HARDWARE		
36	99433002	7/16" SAE Flat Washer	4	99753004	3/4" SAE Flat Washer
6	99621014	5/8" x 1 1/2" Gr. 8 Bolt	4	99752002	3/4"-16 Hex Nut

R-JOINT SPACER INSTALLATION

Install the Spacers by inserting the SMALL side of the SPACER into the Center Pivot Ball. Push them in until they bottom out and stop.

TRAILING ARM R-JOINT

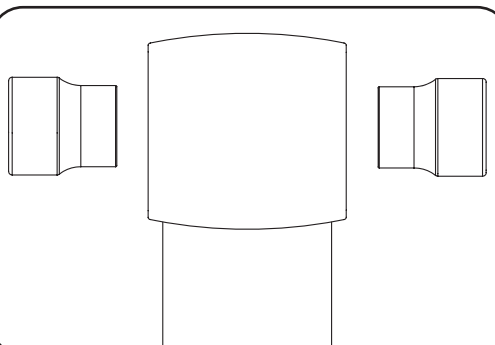

PANHARD R-JOINTS

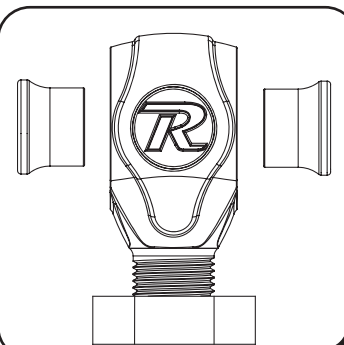

New R-Joints will be quite stiff (75-90 in/lbs breakaway torque) until they "break in" after a few miles of use. After the break in period they will move much more freely. Because the composite bearing race contains self lubricating ingredients, no additional lubrication is needed or desired. Any additional lubrication will only serve to attract more dirt and debris to the R-Joint and actually shorten its life.



Getting Started.....

Congratulations on your purchase of the Ridetech Rear StrongArm System. This system has been designed to give your truck excellent handling along with a lifetime of enjoyment. Some of the key features of this system: C-notches to give your truck a lowered stance, long panhard bar to reduce the side to side movement of the differential, double tube front trailing arm crossmember allows the exhaust to be ran through it, new trailing arms to replace old deteriorated trailing arms, and the biggest feature of all, it allows the use of Shockwaves or Coilovers.

Note: These system is designed for use with the Ridetech Shockwaves or CoilOvers and the MuscleBar swaybar. **The factory shocks and springs or the factory sway bar will not fit these arms.**

Note: This kit is designed for trucks with the factory coil spring setup. It can be used on leaf spring trucks if a Coil spring differential is used or the trailing arm mounts are added to the leaf spring differential.

1. Raise the vehicle to a safe and comfortable working height. Let the rear suspension hang freely.
2. Remove the bed.
3. Raise the axle a couple inches and support it so that it cannot rotate. Remove the trailing arms, coil springs, shock absorbers, and panhard bar. Refer to the factory service manual for proper disassembly procedures.

Note: This kit is designed for use with a 1-piece drive shaft. If your truck has a carrier bearing setup, it will need to be converted to a 1-piece driveshaft to eliminate the carrier bearing.

Disassembly and Front Crossmember Installation



4. The factory trailing arm frame cross member will be replaced with the tubular one supplied. To remove the factory cross member, the rivets must be removed. The easiest method is to chisel them off with an air hammer. Then use a hammer and punch to drive the rivets out.

Note: On each side there is one rivet in front of the cross member and one behind that must also be removed for the new cross member.



"C" Notch Installation



5. Install the new cross member with the trailing arm flanges towards the rear. The cross member is bolted to the bottom side of the frame rails using 10 - 7/16" x 1" bolts, 10 - 7/16" Nylok nuts and 20 - 7/16" flat washers. It may be necessary to enlarge some of the holes with a 7/16" bit.



6. The factory upper shock cross member must also be removed to allow for the new upper shock cross member and "C" Notch.



7. On the driver side of the rear frame cross member; these two rivets must be removed before installing the "C" notch. Also, remove the factory panhard mount.



"C" Notch Installation



8. The lower rear rivet on this reinforcement plate must also be removed to mount the notch.

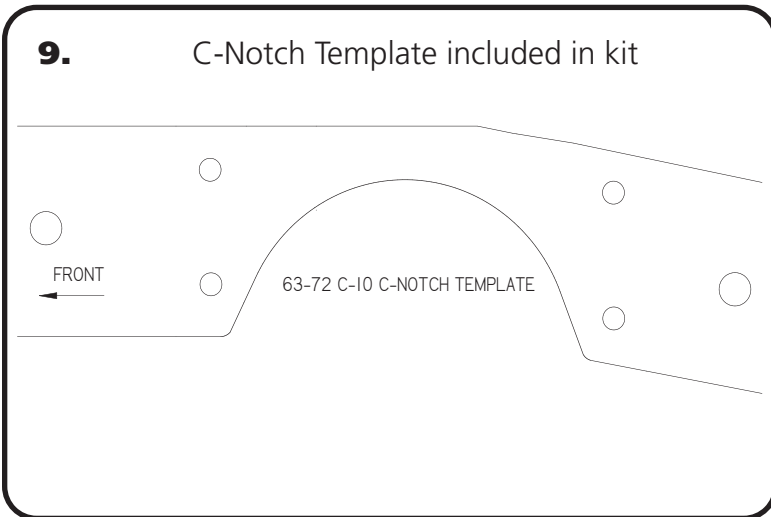

9. Use the supplied "C" Notch template to mark out the frame for cutting. Before cutting out the frame, support the frame in front of and behind the "C" Notch area. We suggest doing one side at a time. The "C" Notch template has an arrow pointing to the front of the truck. Use the 5/8" holes to locate the template of the frame.

Note: We have see trucks with only (1) 5/8" hole. If your truck only has one hole, line it up and then, line up the other edge of the template with the frame rail.



10. The original shock crossmember holes will line up with the holes in the "C" Notch. You can use these holes to double check your Notch placement.



Installing "C" Notches and Shock Bridge



11. Slide the "C" Notch over the frame rail. On some trucks there is just one 5/8" hole, on others there are two holes. Insert 5/8" x 1 1/2" bolt, Nylok nut and flat washer in each hole to secure the notch. The factory rivet holes will need to be drilled out with a 7/16" drill bit. Use the "C" Notch as a template to drill the remaining holes. Attach the c-notch using 7/16" x 1" bolts, Nylok nuts, and flat washers. Leave the front (3) bolts out of the top of both notches and the (2) bottom rear bolts of the drivers side out for the moment.



12. Once both "C" Notches are in place bolt in the upper shock bridge. The new upper shock bridge uses the (3) holes in the top of the "C" Notch. The bridge is offset to the rear of the truck, it goes from "C" Notch to "C" notch under neath the top lip of the frame sandwiching the frame between it and the "C" Notch. It is bolted in place using (6) 7/16" x 1 1/4 bolts, Nylok nuts and flat washers.

IF YOU HAVE A WOODEN BED FLOOR, YOU WILL NEED KIT 11337299 TO SPACE THE SHOCK CROSSMEMBER DOWN. THE SPACERS WILL NEED TO BE BOLTED IN BETWEEN THE CROSSMEMBER AND FRAME.

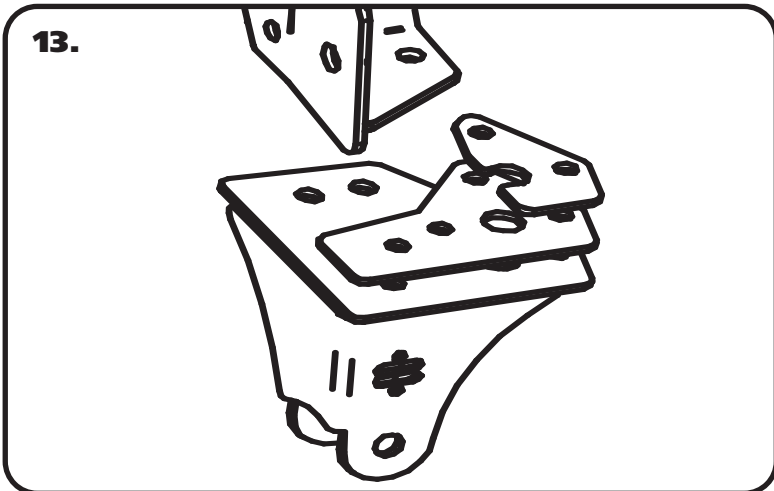

Note: There are four holes on each side of the bridge; only 3 will be used.

13. Bolt the new panhard mount to the bottom side of the frame on the drivers side. The panhard mount uses (2) spacers to mount it properly (See diagram #13 for reference). The new panhard mount is bolted in place using (6) 7/16" x 1 3/4" bolts, Nylok nuts and flat washers.

Torque the 7/16" hardware to 50 ft-lbs.



Installing StrongArms and Panhard Bar

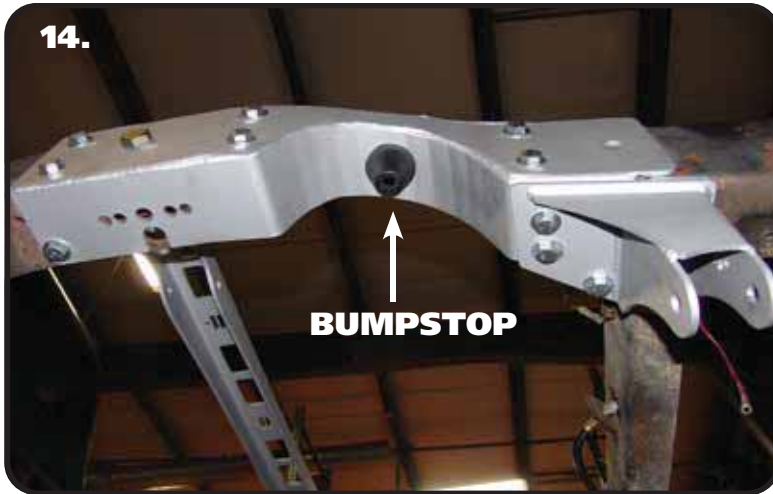

14. Install the bumpstops into the "C" Notch using a 3/8" nut and flat washer.



15. The StrongArms are a direct replacement of the factory trailing arms and will bolt to the new tubular cross member using two 5/8" x 4 1/2" Bolts, 4 Flat Washers, & 2 Nylok nuts. Insert the R Joint Spacers into each side of the R Joint. These bushings are Delrin and do NOT need lubricating. Torque to 115 ft-lbs.

Note: There is a driver and passenger side arm. The shock mount will point towards the center of the vehicle. The Panhard mount is on the Passenger StrongArm.



16. Bolt the other end of the StrongArm to the axle using the new U-bolts supplied. Torque the u-bolts hardware 220-320 ft-lbs.



Installing Panhard Bar and Shockwaves/Coilovers

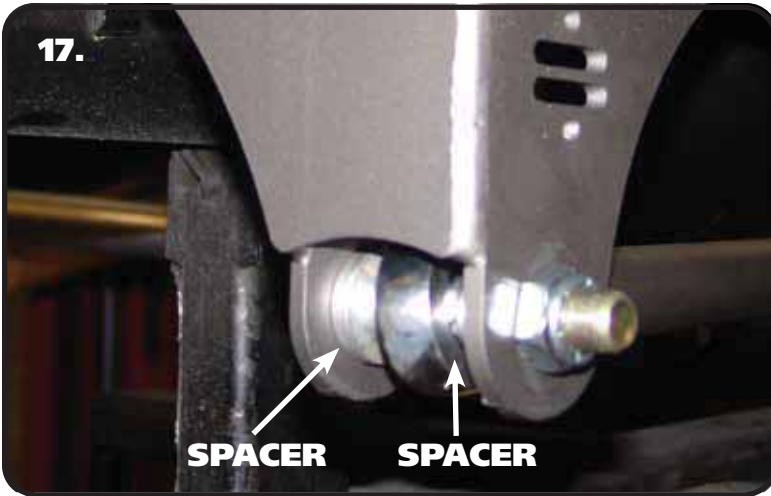

17. Install the Panhard bar into the frame bracket using a 70013334 Spacer in each side of the R-Joint end. The Panhard bar is attached using 5/8" x 2 3/4" bolt and a jam Nylok nut.

Note: The panhard bar is set at 34 5/8" before it is shipped.

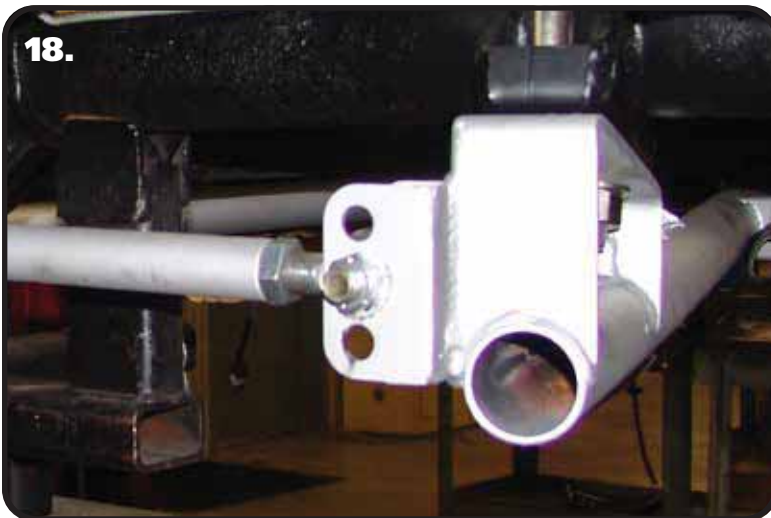

18. Install the other end of the Panhard bar into the bracket on the Passenger StrongArm using a 70013334 Spacer in each side of the R-Joint end. The **center** hole is the standard hole. The goal is to keep the panhard bar level as possible at **ride** height. If you decide to run the system higher or lower than the designed ride height the other 2 holes can be used to help keep the panhard bar level at **ride** height. Torque the 5/8" hardware to 45 ft-lbs.

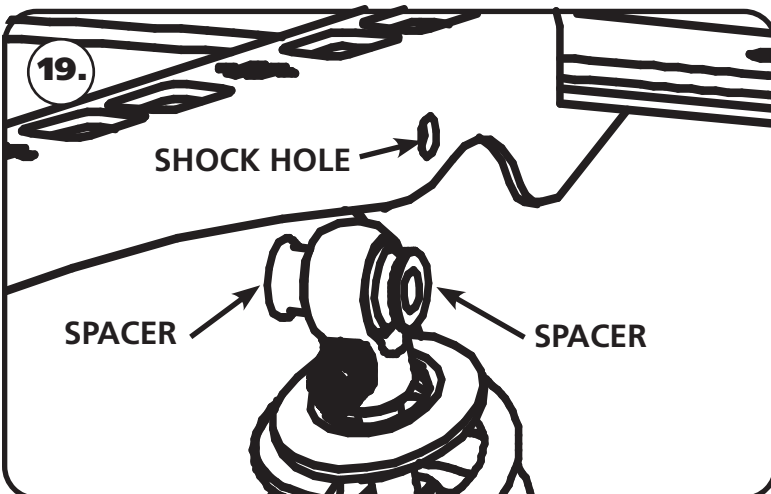

19. Install a spacer on each side of the upper Shockwave/Coilover. Slide the assembly into the upper bridge from the bottom side. If your shock has an adjuster knob position it so that the knob points toward the center of the truck. Line up the hole in the spacers with the hole in the upper shock bridge and insert 1/2" x 3 1/4" bolt and install 1/2" Nylok nut.

Note: If installing Shockwaves and you want to locate the air fitting in a different location, the air spring assembly can be rotated on the shock by grabbing the shock and air spring assembly by hand and spinning the shock in the air spring assembly.



Finishing

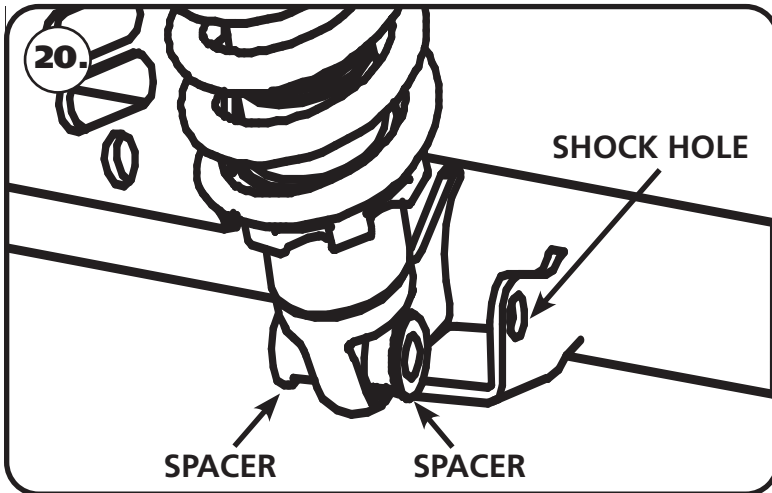

20. Install a spacer on each side of the lower Shockwave/Coilover. Slide the shock with the spacers installed into the mount on the lower StrongArm. You may need to jack the rearend up to line up the holes in the bushing with the 1/2" hole in the shock mounts and hold it in place while you install the 1/2" x 3 1/4" bolt and 1/2" Nylok nut. Tighten the upper and lower shock bolts to 75 ft-lbs.

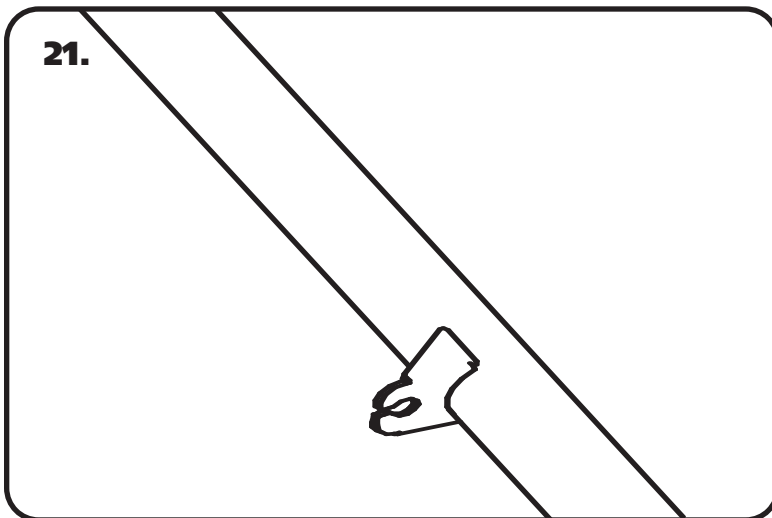

21. The StrongArms have a tab for the emergency brake cable. Install the cable into the tabs and hook the cables back up.

22. Tighten all fasteners. If you are going to install the Ridetech MuscleBar, now is a good time to do it. Reinstall the bed and set the truck back on the ground.

23. Set ride height on the truck. The ride height of the Shockwave/Coilover is approximately 14 1/2". If you are using Shockwaves, this is done by changing the air pressure in the Shockwaves. If you are using Coilovers, the ride height is done by using the adjuster nut for the coil spring. The coil spring on the Coilover will have some preload in the spring to get ride height, this is normal.



Part # 11336511 - 1963-1972 C10 Rear CoilOvers

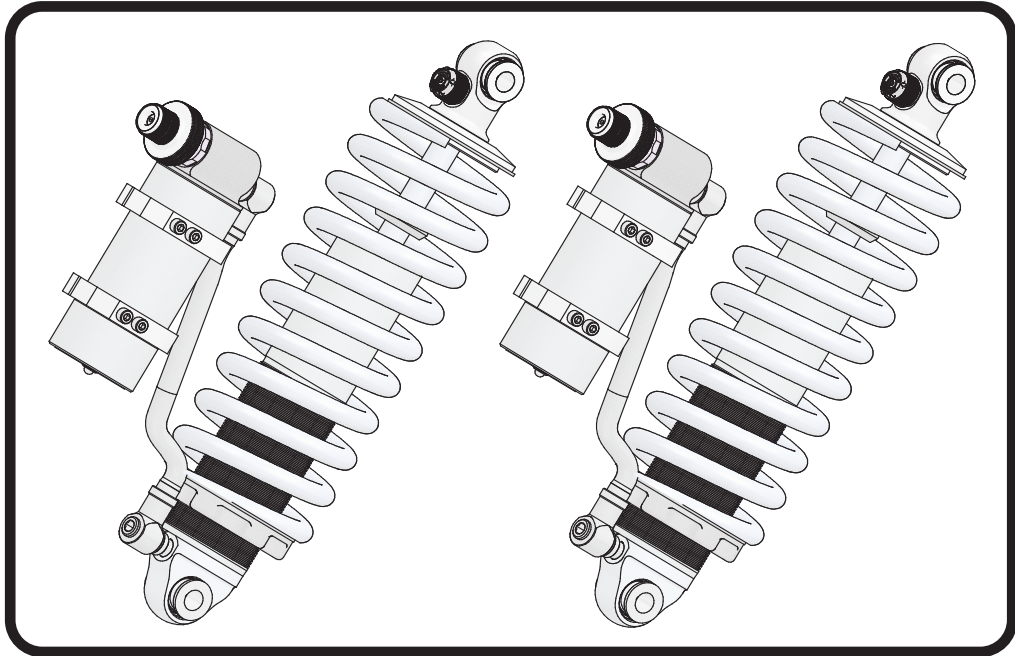

Recommended Tools

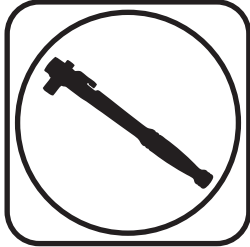

1963-1972 C-10 TQ Series Rear Coilovers Installation Instructions

Table of contents	
Page 35.....	Included Components
Page 36-37.....	Assembly and Adjusting
Page 38.....	Shock Adjustment and Setting Height



Major ComponentsIn the box

Item #	Part #	Description	QTY
1	986-10-072	5.2" Stroke TQ Series Shock	2
2	815-05-022-KIT	1.7" Shock Eyelet	2
3	803-00-199(kit)	Upper Coilspring Mount	2
4	59100275	Coilspring 10" 275lb	2
5	70010828	Delrin Spring Washer	4
6	803-00-199(kit)	Lower Spring Adjuster Nut (803-00-199 kit)	2
	803-00-199(kit)	Adjuster Nut Locking Screw (803-00-199 kit)	2
	803-00-199(kit)	Retaining Ring (803-00-199 kit)	2
9	026-05-000	Reservoir Clamps	4
10	99050000	Reservoir Socket Head Cap Screws	12
11	90001994	5/8" ID Bearing (installed in shock and eyelet)	4
12	90001995	Bearing Snap Ring (installed in shock and eyelet)	8

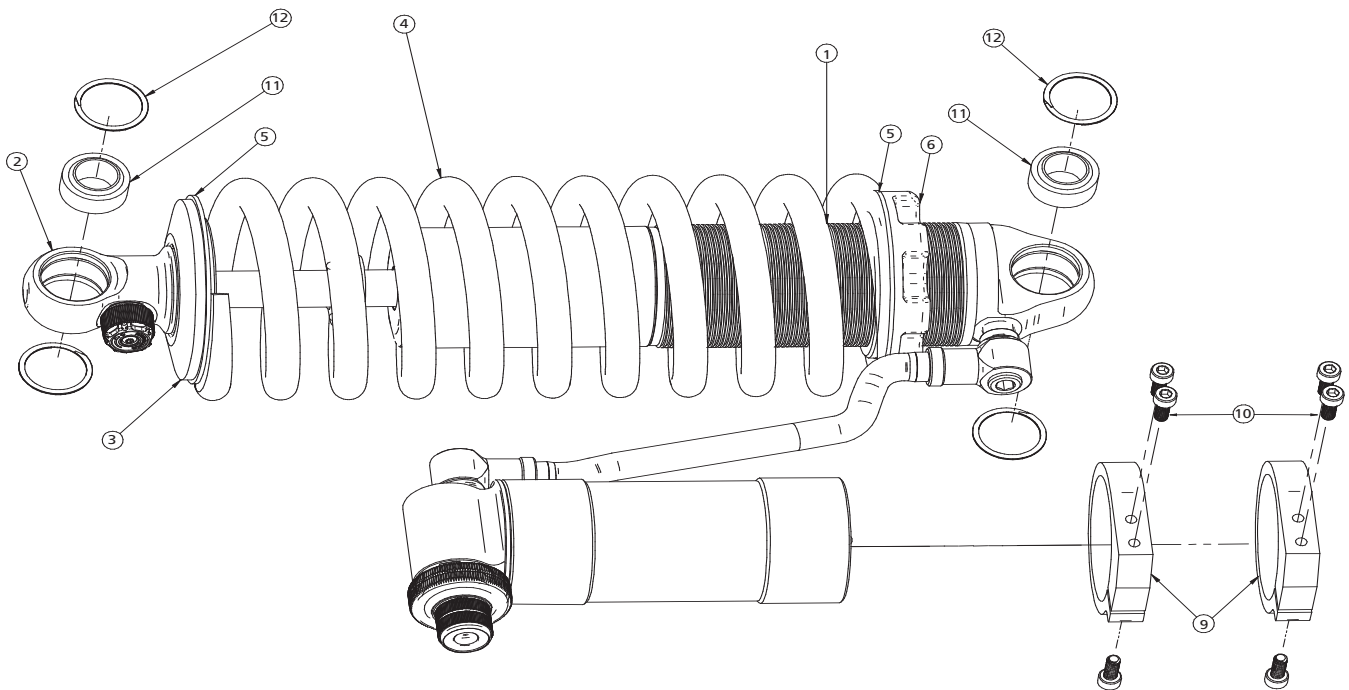

BEARING SPACERS (90002062) ARE INCLUDED WITH THE REAR STRONGARM KIT.

CoilOver Assembly...



1

First, using the supplied lower adjuster nut (803-00-199) thread the nut onto the shock from the bottom side as seen in figure 1. Remove the plastic pellet that is in the split of the adjuster nut.



4

Once the knob is removed slide a Delrin washer over the eyelet. Next, slide the upper spring mount (803-00-199) over eyelet as seen in figure 4.



2

Next, install a delrin washer then coil spring over the top of the shock as seen in figure 2.



5

Install upper spring mount retainer clip (803-00-199) into the groove on the upper eyelet as seen in figure 5. Then, reinstall adjuster to complete assembly.



3

Before the upper spring mount can be installed screw the adjuster knob on the upper eye mount to the firmest setting (clockwise) as seen in figure 3. Then remove the Knob by holding it while removing the center screw.

Install the locking screw in the adjuster nut before setting spring preload, but DO NOT tighten until the spring preload has been set.

NOTE: Remember to adjust the shock valving before driving, the shock is currently set to full stiff.

Shock Adjustment 101- Single Adjustable

Rebound Adjustment:

How to adjust your new shocks.

The rebound adjustment knob is located on the top of the shock absorber protruding from the eyelet. You must first begin at the ZERO setting, then set the shock to a medium setting of 12.



-Begin with the shocks adjusted to the ZERO rebound position (full stiff). Do this by rotating the rebound adjuster knob clockwise until it stops.



-Now turn the rebound adjuster knob counter clock wise 12 clicks. This sets the shock at 12. (settings 21-24 are typically too soft for street use).

Take the vehicle for a test drive.



-if you are satisfied with the ride quality, do not do anything, you are set!

-if the ride quality is too soft increase the damping effect by rotating the rebound knob clock wise 3 clicks.

Take the vehicle for another test drive.



-if the vehicle is too soft increase the damping effect by rotating the rebound knob clock wise 3 additional clicks.



-If the vehicle is too stiff rotate the rebound adjustment knob counter clock wise 2 clicks and you are set!

Take the vehicle for another test drive and repeat the above steps until the ride quality is satisfactory.

Note:

One end of the vehicle will likely reach the desired setting before the other end. If this happens stop adjusting the satisfied end and keep adjusting the unsatisfied end until the overall ride quality is satisfactory.



Shock Adjustment

Shock Adjustment 101- Triple Adjustable

Triple Adjustable:

Step One: High Speed Compression



-High speed compression adjustments are used in both street driving and track tuning.

-Begin with the shocks adjusted to the ZERO high speed compression position (full stiff). Do this by rotating the high speed compression adjuster (large knob) clockwise until it stops.

-Now turn the high speed compression adjuster knob counter clock wise 20 clicks. This sets the shock at 20. (settings 21-24 are typically too soft for street use. For typical street driving the high speed compression adjuster will remain at setting 20.

Step Two: Low Speed Compression

Low speed compression adjustment is what is typically felt during street driving.



-Begin with the shocks adjusted to the ZERO low speed compression position (full stiff). Do this by rotating the low speed compression adjuster (small knob) clockwise until it stops.

-Now turn the low speed compression adjuster knob counter clock wise 20 clicks. This sets the shock at 20. (settings 21-24 are typically too soft for street use). Take the vehicle for a test drive.

-if you are satisfied with the ride quality, do not do anything, you are set!

-if the ride quality is too soft increase the damping effect by rotating the low speed compression knob clock wise 3 clicks.

Take the vehicle for another test drive.



-if the vehicle is too soft increase the damping effect by rotating the low speed compression knob clock wise 3 additional clicks.

-If the vehicle is too stiff rotate the low speed compression adjustment knob counter clock wise 2 clicks and you are set!

Take the vehicle for another test drive and repeat the above steps until the ride quality is satisfactory.

Step 3:

Adjust rebound according to Single Adjustable instructions.

Note:

One end of the vehicle will likely reach the desired setting before the other end. If this happens stop adjusting the satisfied end and keep adjusting the unsatisfied end until the overall ride quality is satisfactory.



Final Tightening and Adjusting

Ride Height

We have designed most cars to have a ride height of about 2" lower than factory. To achieve the best ride quality & handling, the shock absorber needs to be at 40-60% overall travel when the car is at ride height. This will ensure that the shock will not bottom out or top out over even the largest bumps. Measuring the shock can be difficult, especially on some front suspensions. Measuring overall wheel travel is just as effective and can be much easier. Most cars will have 4-6" of overall wheel travel. One easy way to determine where you are at in wheel travel is to take a measurement from the fender lip (center of the wheel) to the ground. Then lift the car by the frame until the wheel is just touching the ground, re-measure. This will indicate how far you are from full extension of the shock. A minimum of 1.5" of extension travel (at the wheel) is needed to ensure that the shock does not top out. If you are more than 3" from full extension of the shock then you are in danger of bottoming out the shock absorber.

Adjusting Spring Height

When assembling the CoilOver, screw the spring retainer tight up to the spring (0 preload). After entire weight of car is on the wheels, jounce the suspension and roll the car forward and backward to alleviate suspension bind.

- If the car is too high w/ 0 preload then a smaller rate spring is required. Although threading the spring retainer down would lower the car, this could allow the spring to fall out of its seat when lifting the car by the frame.
- If the car is too low w/ 0 preload, then preload can then be added by threading the spring retainer up to achieve ride height. On 2.6" - 4" stroke shocks, up to 1.5" of preload is acceptable. On 5-7" stroke shocks, up to 2.5" of preload is acceptable. If more preload is needed to achieve ride height a stiffer spring rate is required. Too much preload may lead to coil bind, causing ride quality to suffer.