



Part # 11360301 - 73-87 C10 CoilOver System

Front Components:

11362699	Front StrongArm System
11369300	Front Spindles and Caliper Brackets
11363511	Front Coilovers
11369120	Front Sway Bar

Rear Components:

11367199	Rear StrongArm System
11366511	Rear Coilover Instructions

Miscellaneous Components:

85000000	Spanner Wrench
----------	----------------

Recommended Tools

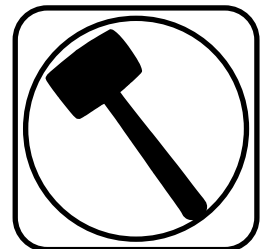
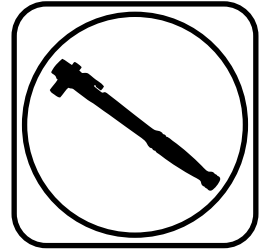

73-87 C-10 Coilover System Installation Instructions

Table of contents

Pages 2-14.....	Front StrongArm System
Pages 15-16.....	Front Coilovers
Pages 17.....	Spindles
Pages 18-22.....	Front Sway Bar
Pages 23-33.....	Rear 4 Link Kit
Pages 34-35.....	Rear CoilOver
Pages 36-38.....	Coilover Assembly and Adjustment

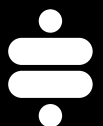



Part # **11342699**⁽⁶³⁻⁷⁰⁾/**11352699**⁽⁷¹⁻⁷²⁾ - C10 StrongArms

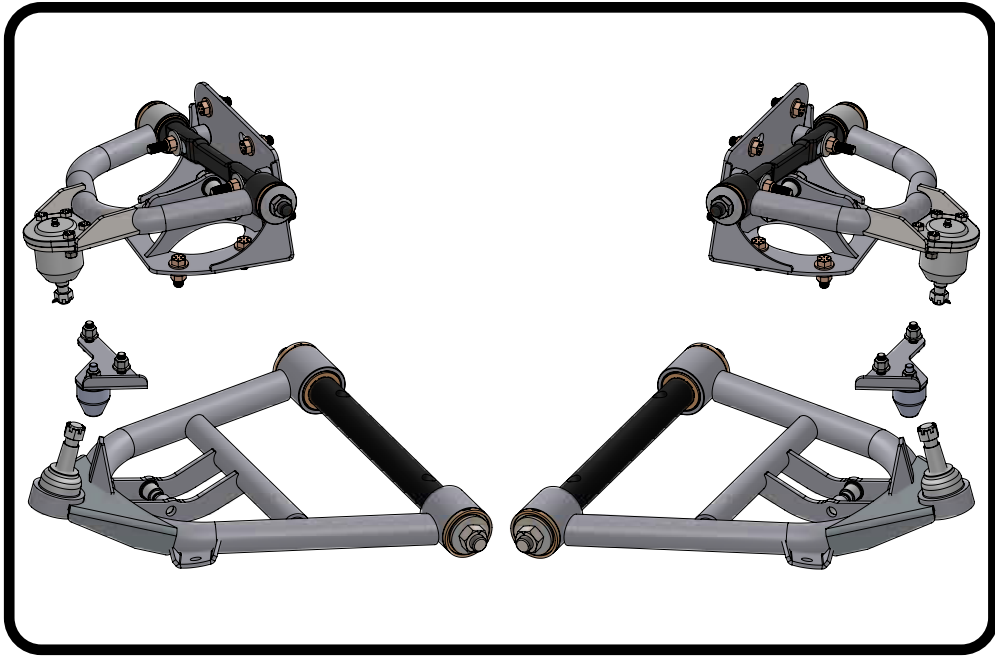

Recommended Tools

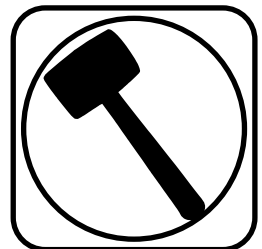
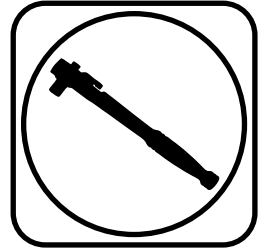

1963-1972 C-10 StrongArms Installation Instructions

Table of contents

- Page 3..... Component Assemblies
- Page 4..... Lower Control Arm Components
- Page 5..... Upper Control Arm Components
- Page 6..... Hardware List and Getting Started
- Page 7..... Installing Upper Control Arm Mount
- Page 8..... Installing Upper Control Arm Mount and Upper Arm
- Page 9..... Caster Explained
- Page 10..... Offset Upper Cross Shaft
- Page 11..... Installing Upper and Lower Control Arm
- Page 12..... Installing CoilOver Assembly
- Page 13..... Finishing and Alignment
- Page 14..... Crossmember Trimming Template



Major Components AssembledIn the box

DRIVER UPPER CONTROL ARM ASSEMBLY

Exploded View on Page 5

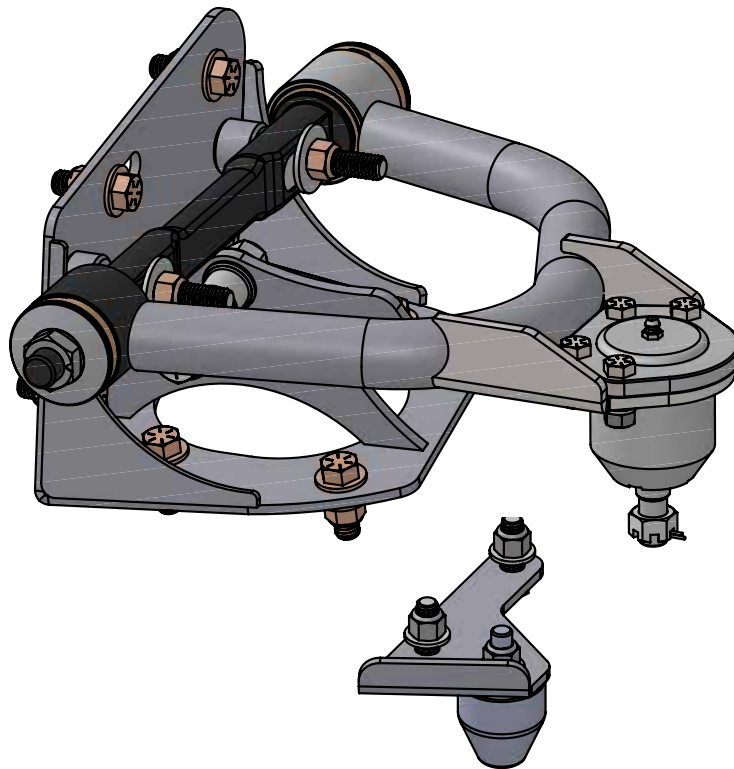

DRIVER LOWER CONTROL ARM ASSEMBLY

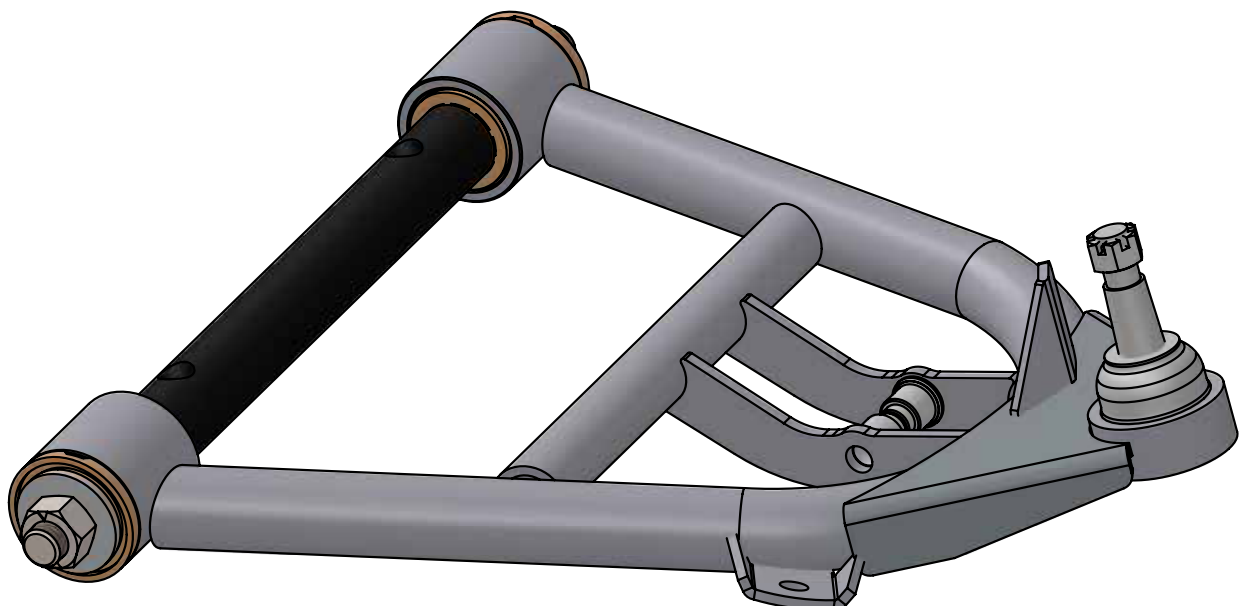



Lower Control Arm ComponentsIn the box

Item #	Part Number	Description	QTY
1	90002384	Driver Lower Control Arm (Shown)	1
1	90002385	Passenger Lower Control Arm	1
2	90002430	Lower Control Arm Cross Shaft	2
3	90000912/90000909	(63-70/71-87) - Lower Ball Joint Assembly	2
4	99753001	Flat Washer - included in hardware kit	4
5	99752005	3/4"-16 Hex Nut - included in hardware kit	4
6	70010755	Outer Delrin Bushing - with Ledge	4
7	70011465	Inner Delrin Bushing - no Ledge	4
8	90002062	Shock Bearing Spacers	4

Driver Side Shown

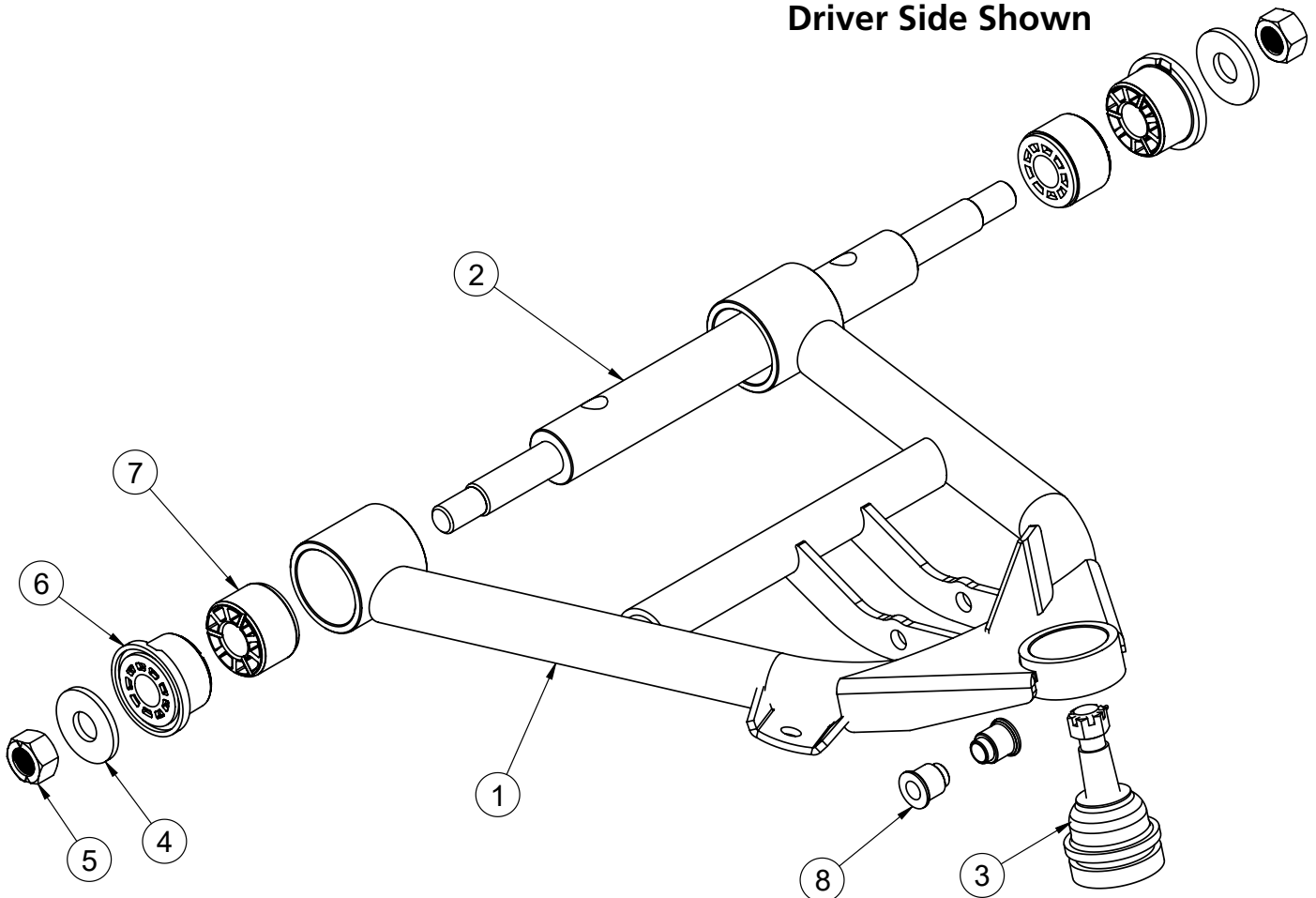



Upper Control Arm ComponentsIn the box

Item #	Part Number	Description	QTY
8	90002062	Shock Bearing Spacers	4
9	90002437	Driver Upper Control Arm (Shown)	1
9	90002438	Passenger Upper Control Arm	1
10	90003375	Caster Adjustable Upper Control Arm Shaft	2
11	70010759	Outer Delrin Bushing	4
12	70010827	Inner Delrin Bushing - with Ledge	2
13	70010826	Inner Delrin Bushing - No Ledge	2
14	90003933	WASHER; 1.45OD	2
15	90003934	WASHER; 1.70OD	2
16	90002737	Delrin Bushing T-Washer	4
17	99622005	5/8 - 18 Locknut (included with 90000914)	4
18	70010882	Caster Slug	4
19	90000911 Kit/90000902 Kit/90000910 Kit	(63-70/71-72/73-87) - Upper Ball Joint Assembly	2
20	90002386	Driver Upper Control Arm Mount	1
20	90002387	Passenger Upper Control Arm Mount (Not Shown)	1
21	90000726	Driver Bumpstop Plate	1
21	90000727	Passenger Bumpstop Plate (Not Shown)	1
22	70013323	Bumpstop	2

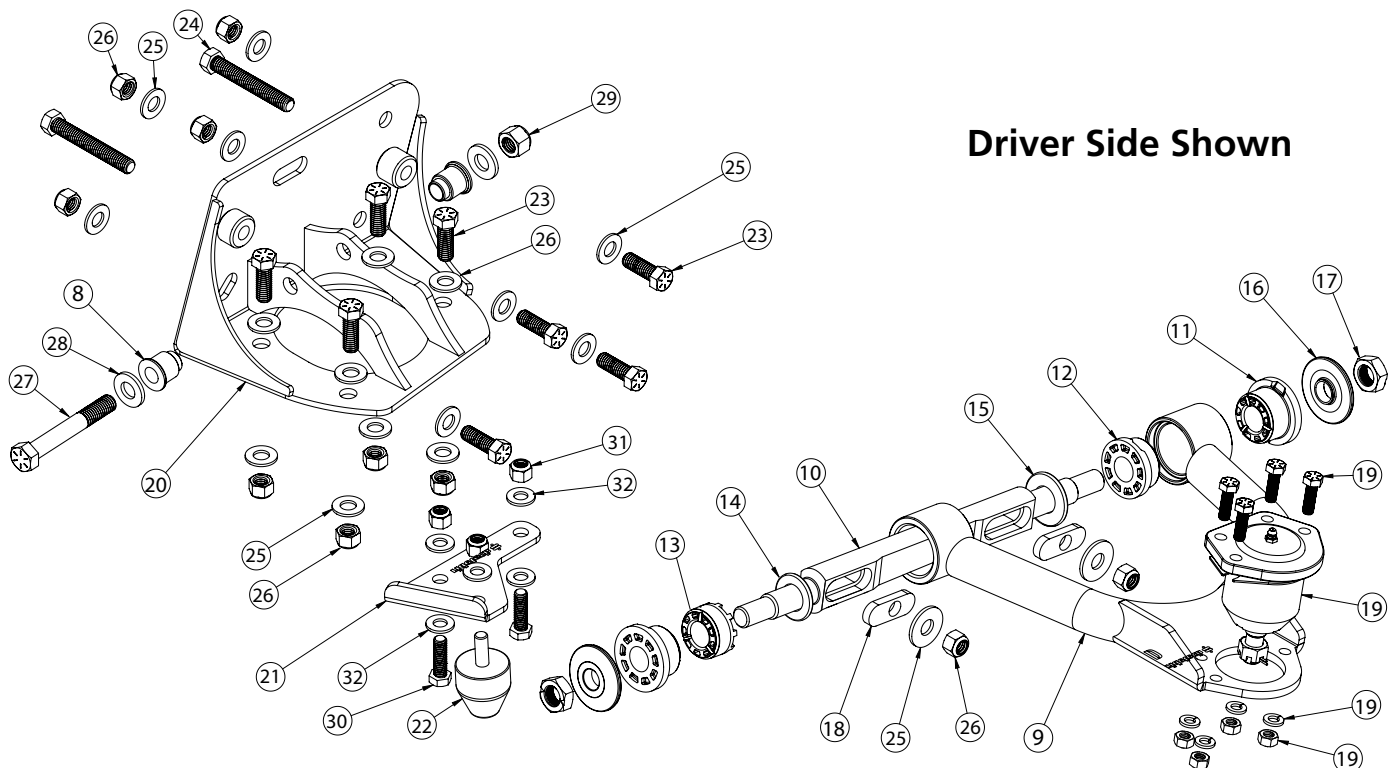



Hardware ListIn the box Kit #99010079

Item #	Part Number	Description		QTY
21	99431002	7/16"-14x1 1/4" Hex Bolt	Upper Control Arm Mount	16
22	99431003	7/16"-14x3" Hex Bolt	Upper Control Arm to Mount	4
23	99433002	7/16" Flat Washer	Upper Mount to Frame/Control Arm to Mount	20
24	99432001	7/16"-14 Nylok Nut	Upper Mount to Frame/Control Arm to Mount	20
25	99501024	1/2"-13x3 1/2" Hex Bolt	Coilover to Arm and Upper Mount	4
26	99503014	1/2" SAE Flat Washer	Coilover to Arm and Upper Mount	8
27	99502001	1/2"-13 Nylok Nut	Coilover to Arm and Upper Mount	4
28	99371006	3/8"-16x1 1/2" Hex Bolt	Bumpstop Mount to Frame	4
29	99372002	3/8"-16 Nylok Nut	Bumpstop & Bumpstop Mount to Frame	6
30	99373003	3/8" SAE Flat Washer	Bumpstop & Bumpstop Mount to Frame	10

Getting Started.....

Congratulations on your purchase of the Ridetech StrongArm System. These arms have been designed to give your truck excellent handling along with a lifetime of enjoyment. Some of the key features of these StrongArms: Ball joint angles have been optimized for the lowered ride height, Delrin bushings are used for no bushing deflection along with providing free suspension movement through the entire travel. The Delrin bushings are made from a material that is self lubricating so no grease zerks are needed. Upper caster adjustable cross shaft is designed to allow you to run maximum caster angles with minimal shims.

Note: These control arms are designed for use with the Ridetech CoilOvers and the MuscleBar swaybar. **The factory shocks and springs or the factory sway bar will not fit these arms.**

Note: The arms in this kit are designed to be used with 63-87 C-10 Spindles. The 63-87 C-10's have similar control arms through the years, but the ball joints used were different. The year breaks are as follows: 63-70, 71-72, & 73-87. Be sure to use the correct ball joint for the year of spindle you are using.

Balljoints:	Ridetech#	Proforged#	Ridetech#	Proforged#
63-70:	Upper-90000911	101-10037	Lower-90000912	101-10036
71-72:	Upper-90000902	101-10044	Lower-90000909	101-10040
73-87:	Upper-90000910	101-10046	Lower-90000909	101-10040

Installation

1. Remove the entire front suspension from the truck leaving the tie rods connected to the center draglink. Refer to the factory service manual for disassembly procedure. Your original spindle will be reused with this setup, set them to the side for the time being. The original U-bolts for the lower control arms will be reused to fasten your new StrongArms to the frame.



Installing Upper Control Arm Mount



2. The factory upper control arm mount will need to be removed from the frame. There are 4 bolts attaching it to the frame rail with 4 rivets attaching it to the crossmember. There are several methods that can be used to remove the rivets from the crossmember. One way is to cut a "+" in the head of the rivet and chisel the 4 pieces of the head off the rivet, then knock the rivet out of the frame with a hammer and punch.



3. The top side of the crossmember will also need trimmed for CoilOver clearance. **A TEMPLATE IS PROVIDED ON PAGE 13.** Cut out the holes in the template and place on top of the crossmember. Trace the template onto the crossmember and cut out the center portion. The Template is a guide to the minimum amount that needs to be cut out. Due to variations in the crossmembers, you may need to trim more to get the upper mount to sit flat on top of the crossmember.

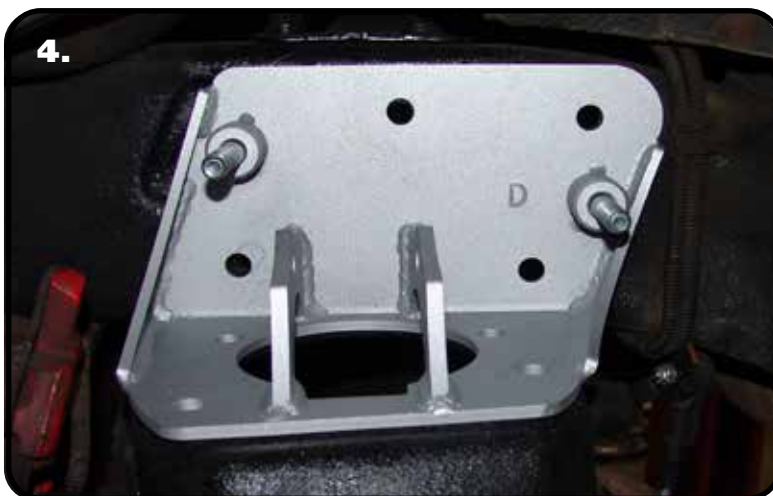

4. Before installing the mount, install the 7/16" x 3" bolts into the upper mount from the back side with the threads pointing towards the wheel side of the bracket. Set the upper control arm mount into position on the frame. The upper brackets are marked D & P for driver & passenger. The brackets get bolted to the frame with 7/16" x 1 1/4" hex bolts and Nylok nuts. The bracket also gets a 7/16" washer under the bolt and under the nut. Due to variances in the frames it may be necessary to drill out the front lower hole. Torque the 7/16" hardware to 50 ftlbs.



Installing Upper Control Arm Mount and Control Arm

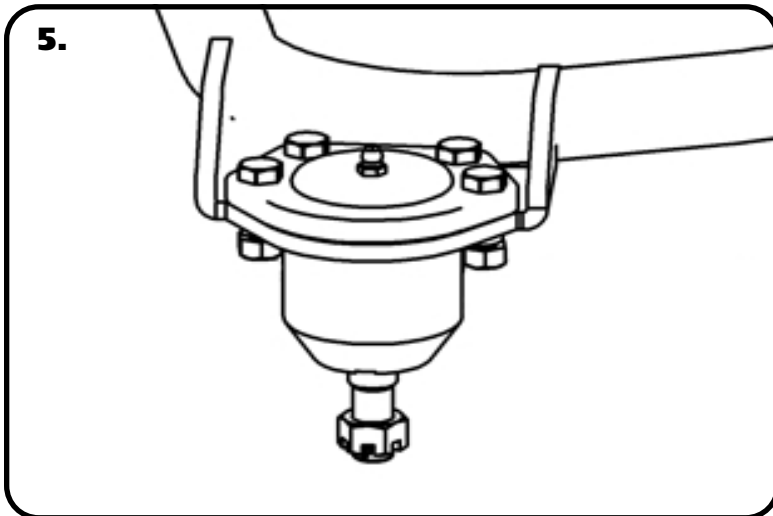

5. Install the ball joints into the upper control arm with the hardware supplied with the ball joint. The upper ball joint goes in from the top side of the control arm. The gussets on the ball joint plate point up. Torque the mounting hardware to 29 ftlbs.

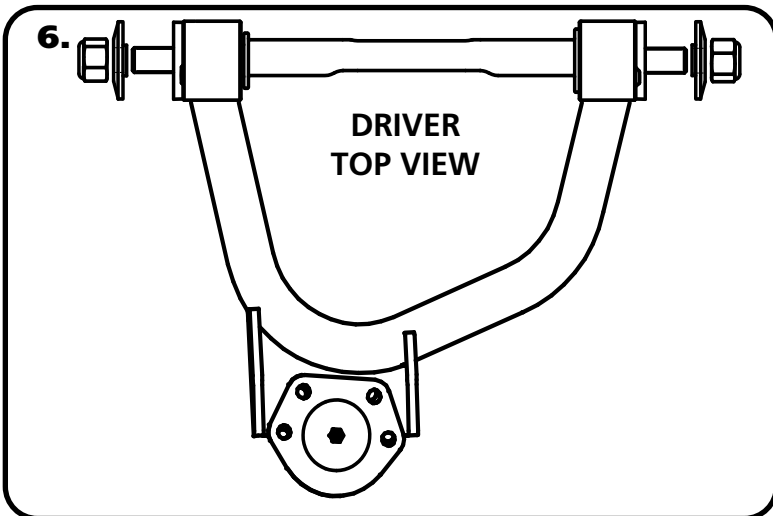

6. The driver side arm is shown in **Figure "6"**. The Ball Joint located on the arm to the front of the truck. Install the T-Washers and 5/8"-18 Lock Nuts using **Figure "6"** as a reference. These can be tightened after installing the control arms on the truck.

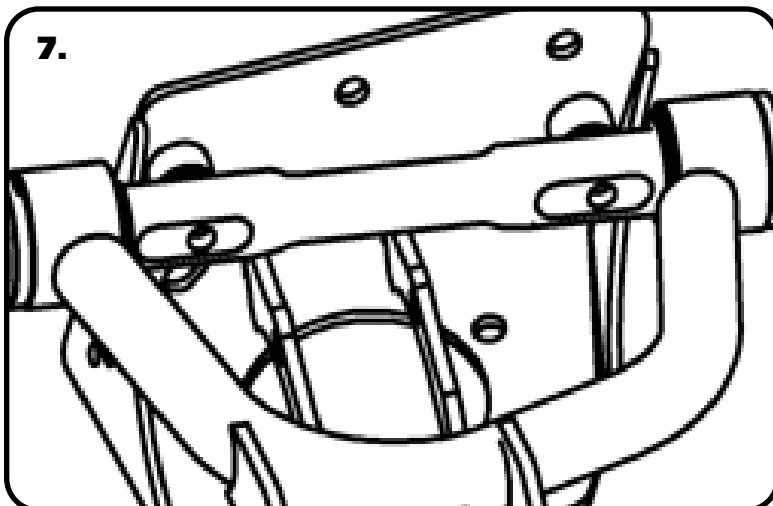

7. Install the caster slugs into the cross shaft. The long side of the caster slug goes to the **rear** of the truck. Use the diagram on the next page as a reference for installing the caster slugs. The cross shaft is attached to the truck using a 7/16" USS Flat Washer & 7/16" Nylok Nut. The drivers side is shown in **Figure "8"**. Now tighten the 5/18"-18 locknuts on the cross shaft. This nut gets snugged up. You want the suspension to be able to move freely.



Caster Explained

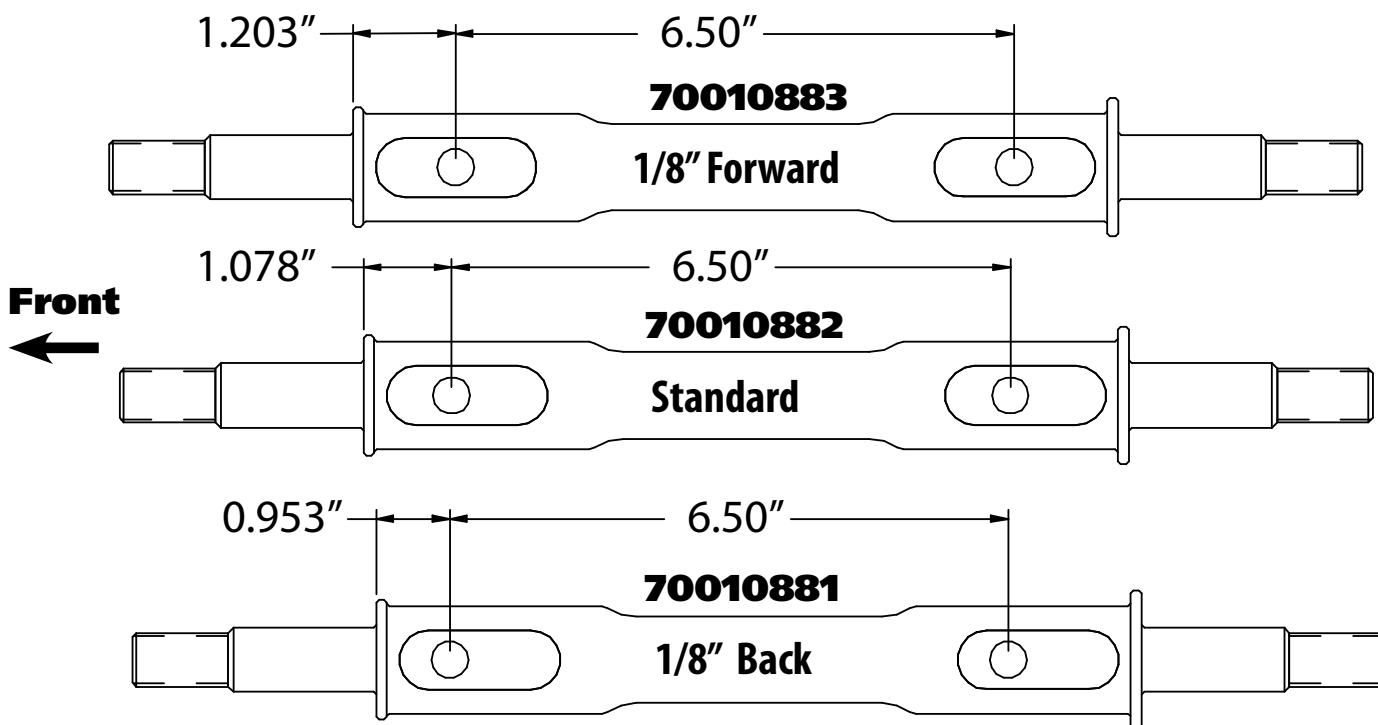

Caster Explained:



Offset Upper Control Arm Shaft

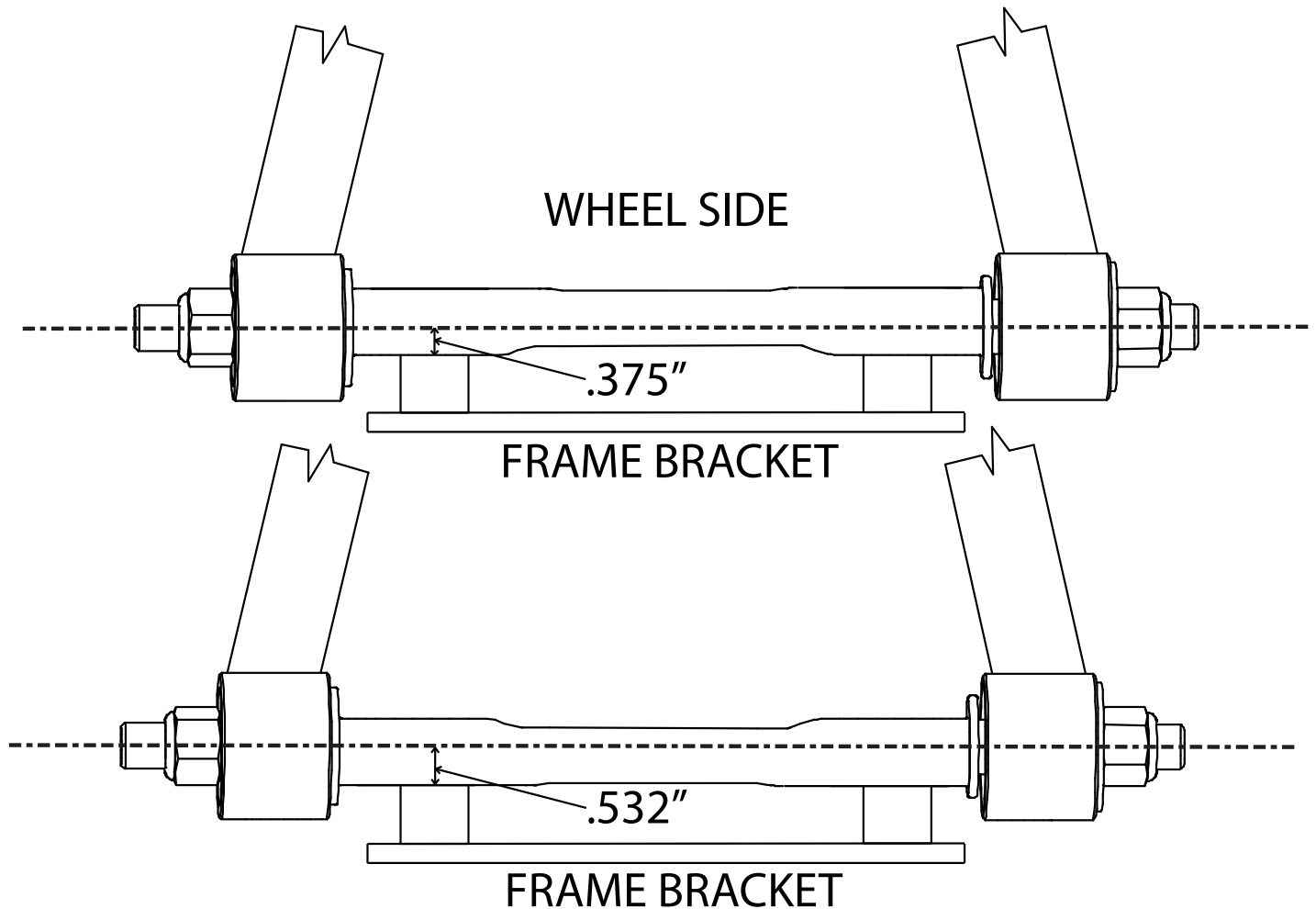

The cross shaft that is used in the upper control arms is offset. The offset combined with the caster slug option allows you to achieve the alignment setting you desire with minimal shims. To change the direction the Icon faces simply spin the cross shaft in the control arm.

If you are after a **Street Alignment** bolt the upper control arm to the frame mount with the arm offset to the outside of the truck. The Ridetech Icon will be facing the wheel.

If a more aggressive **Track or Autocross** alignment is desired, bolt the control arm to the frame bracket with the arm offset to the inside of the truck. The Ridetech Icon will be facing the frame rail.



Installing Upper and Lower Control Arm



8. The lower control arm is installed using the factory u-bolts and nuts. The lower control arm is located by a pin that is in the center of the front u-bolt cradle. This pin will go into the hole in the control arm shaft to help locate the control arm. Bolt the control arm to the frame with the sway bar tab to the front of the truck.

NOTE: We have encountered some trucks where the rear pin is the locator pin. It will locate the control arm correctly too.

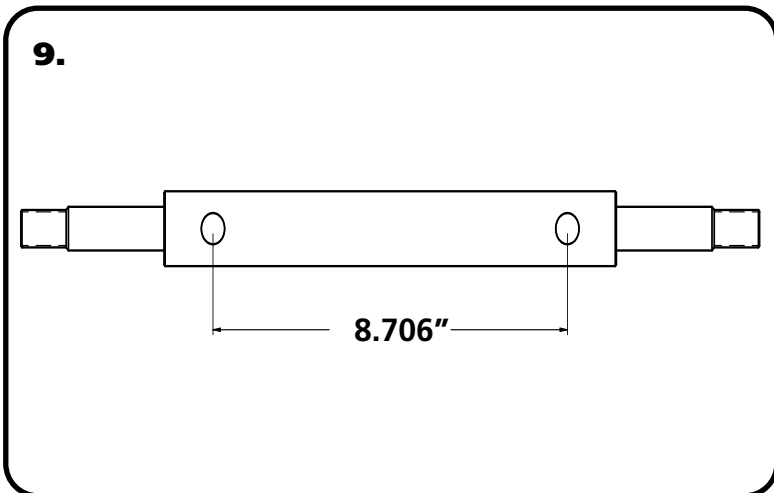

9. The Lower Cross Shaft has 2 different locating hole patterns. These StrongArms use the 8.706" center to center locating holes. The Pin in the Cross Shaft Saddle that was pointed out in **Image 8**, will locate into these Holes. Use the OEM Hardware to attach the Lower making sure the Locating Pin is in the 8.706" center to center Holes.



10. **Image 10** is an example of the lower control arm bolted to the crossmember. Install 3/4" ID Washer on to each end of the cross shaft against the bushing. Then install the 3/4"-16 lock nut. Snug the nut up against the washer. You want the suspension to move freely through its travel.



Installing CoilOver Assembly

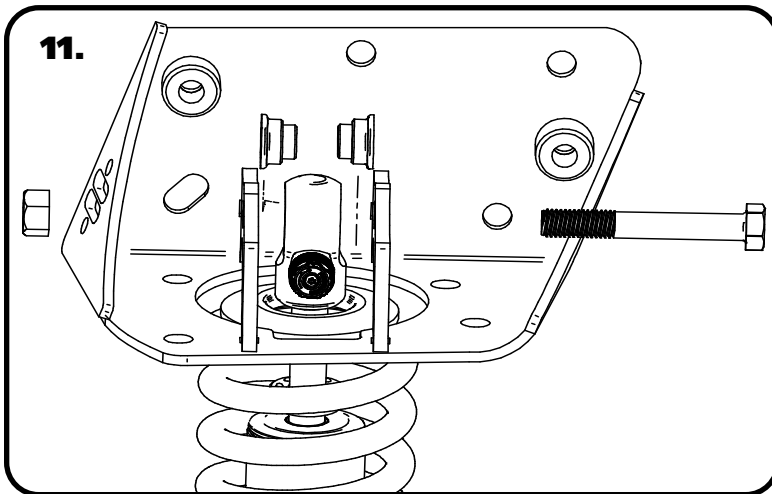

11. Install a spacer on each side of the upper Coilover. The small outside diameter of the spacer will insert into the shock bearing. Push the spacer in until it bottoms out in the bearing. Slide the assembly into the upper mount from the bottom side. If your shock has an adjuster knob position it to the wheel side of the mount. Line up the hole in the spacers with the hole in the strap and insert 1/2" x 3 1/2" bolt and install 1/2" Nylok nut.

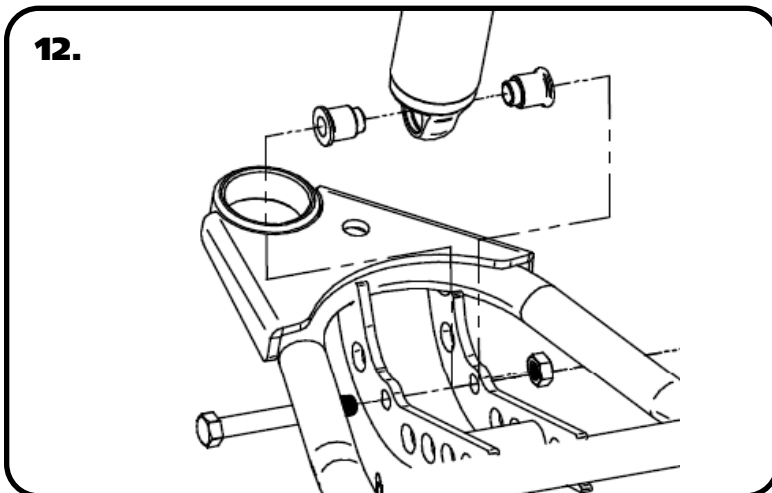

12. Install a spacer on each side of the lower Coilover. The small outside diameter of the spacer will insert into the shock bearing. Push the spacer in until it bottoms out in the bearing. Slide the shock with the spacers installed into the lower control arm. Raise the arm up to line up the holes in the bushing with the 1/2" hole in the control arm straps and hold it in place while you install the 1/2" x 3 1/2" bolt and 1/2" Nylok nut. Tighten the upper and lower shock bolts to 75 ftlbs.



13. Depending on your wheel size, you may need an external bumpstop to keep the tire from hitting the inner fender. The bump stop plate attaches to the wheel side of the crossmember. The bent tab goes against the back side of the crossmember with the holes as far out as you can drill them. Use the mount as a template to drill the holes and attach mount with the remaining 3/8 x 1 1/2" bolts washers and Nylok. After mounting the plate, you can attach the bumpstop. Torque the 3/8" hardware to 30 ftlbs.



Finishing & Alignment

14. The final step is to reinstall the spindle onto the truck. Slide the ball joint pins into the spindle and install the castle nut on each one. Torque the ball joint nuts and install cotter pins in each one.

Ball Joint nut Torque Specs:

Upper: Torque to 50 ftlbs and then tighten nut to align cotter pin hole not exceeding 90 ftlbs.

Lower: Torque to 90 ftlbs and then tighten nut to align cotter pin hole not to exceeding 130 ftlbs.

Suggested Alignment Specs:

Camber: Street: -.5 degrees

Caster: Street: +3.0 to + 5.0 degrees

Toe: Street: 1/16" to 1/8" toe in

UPPER CROSSMEMBER TRIMMING TEMPLATE FOR COILOVER

DRIVER

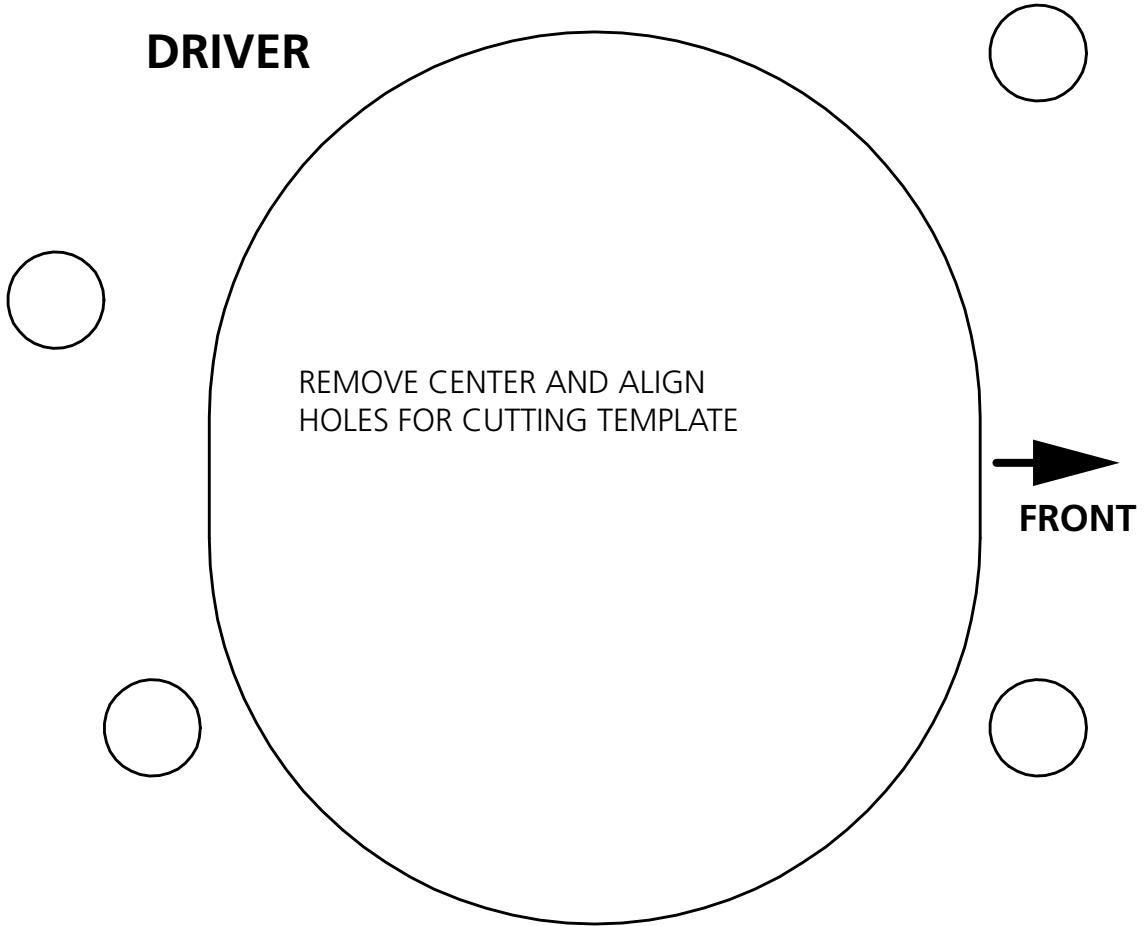

PASSENGER

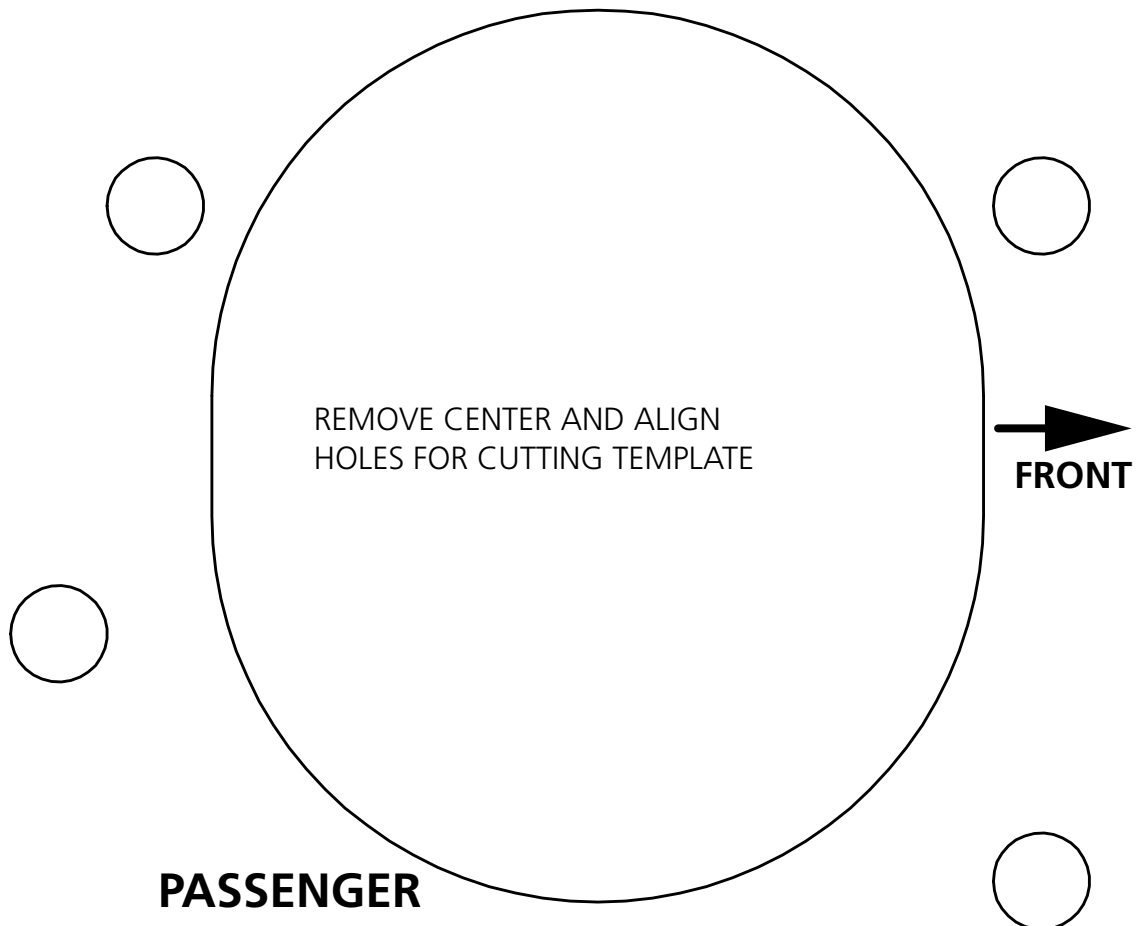



Part # 11363511 - 1973-1987 C10 Front CoilOvers

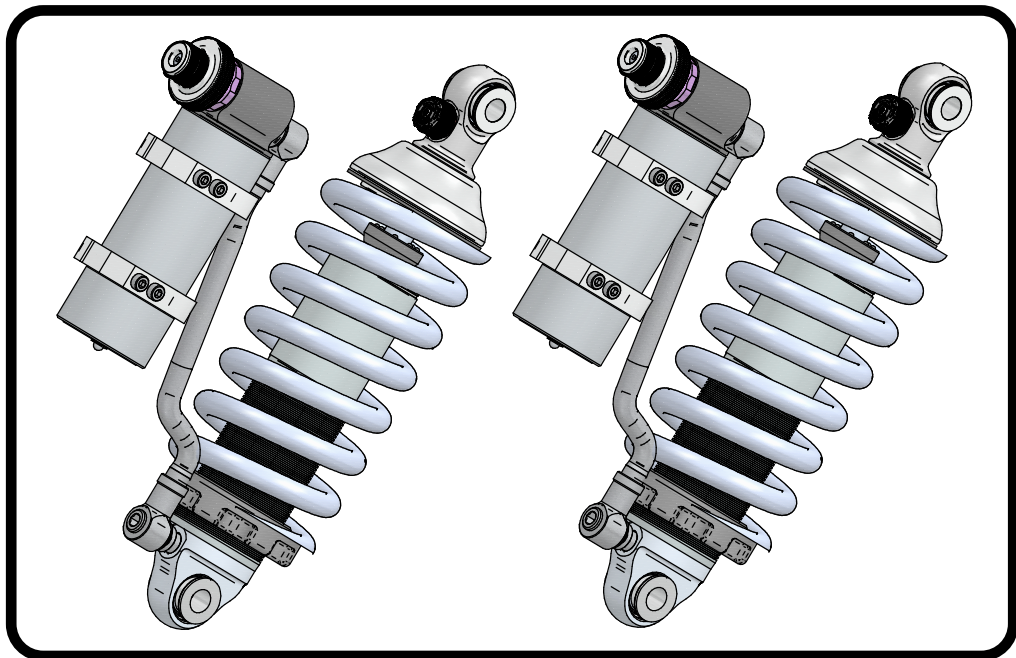

Recommended Tools

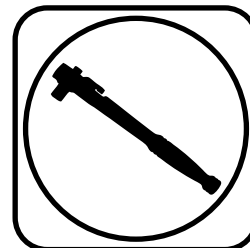
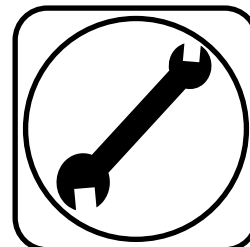
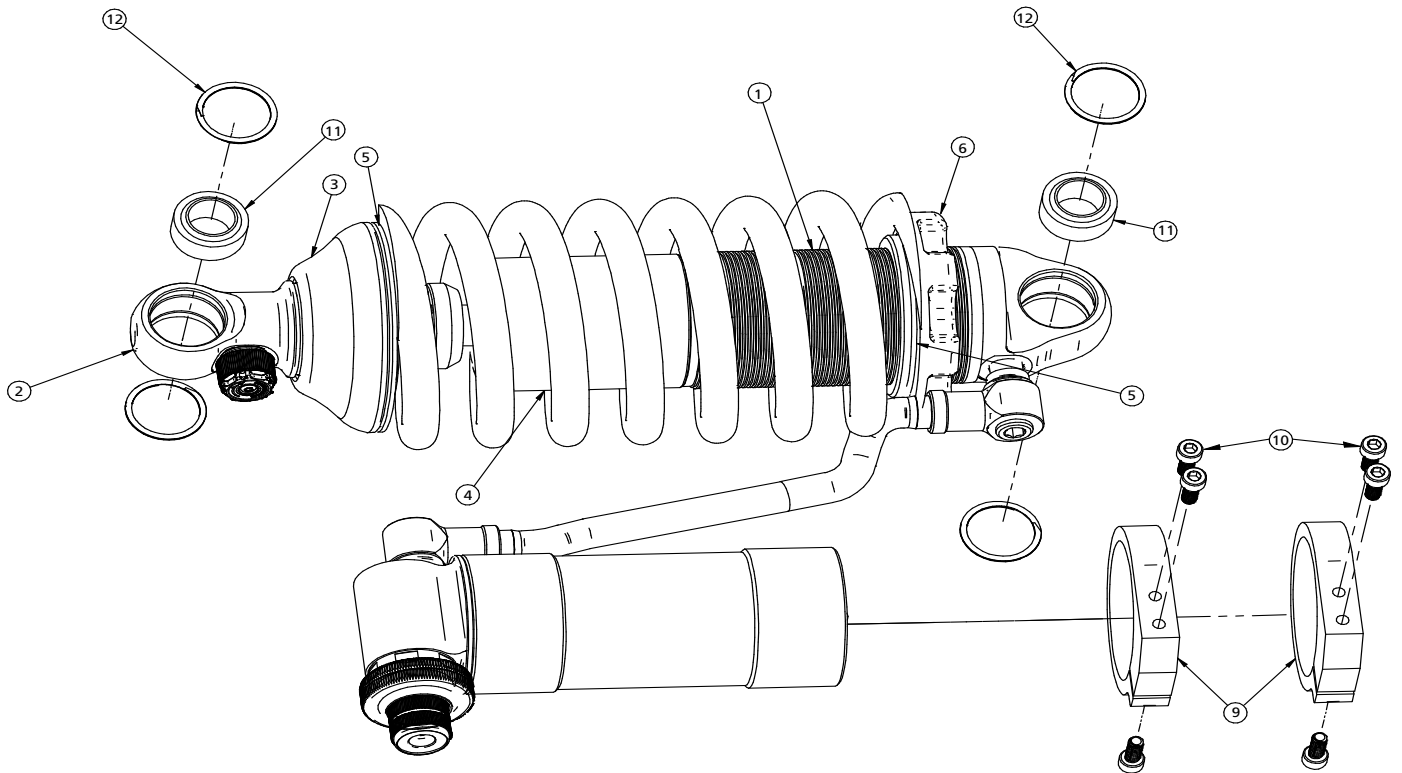

Table of contents
Page 16..... Included components



Major ComponentsIn the box

Item #	Part #	Description	QTY
1	986-10-070	3.6" Stroke TQ Series Shock	2
2	815-05-022-KIT	1.7" Shock Eyelet	2
3	90002070	Dropped Coilspring Cap	2
4	59070800	Coilspring 7" 800lb	2
5	70010828	Delrin Spring Washer	4
6	803-00-199(kit)	Lower Spring Adjuster Nut (803-00-199 kit)	2
	803-00-199(kit)	Adjuster Nut Locking Screw (803-00-199 kit)	2
	803-00-199(kit)	Retaining Ring (803-00-199 kit)	2
9	026-05-000	Reservoir Clamps	4
10	99050000	Reservoir Socket Head Cap Screws	12
11	90001994	5/8" ID Bearing (installed in shock and eyelet)	4
12	90001995	Bearing Snap Ring (installed in shock and eyelet)	8



BEARING SPACERS (90002062) ARE INCLUDED WITH THE FRONT CONTROL ARMS



Part # 11369300 - 73-87 C10 Drop Spindles

Recommended Tools

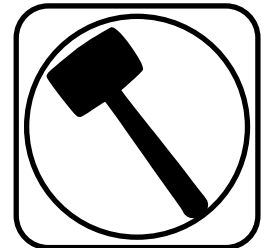
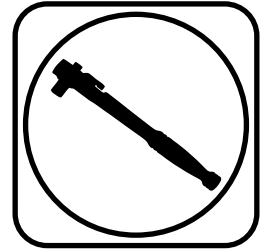

Major ComponentsIn the box

1	11369301	Pair of drop spindles
1	90001926	Pair of caliper brackets

Installation

Balljoint nut Torque Specs:

Upper: Torque to 50 ft lbs and then tighten nut to align cotter pin hole not exceeding 90ft lbs.

Lower: Torque to 90 ft lbs and then tighten nut to align cotter pin hole not to exceeding 130 ft lbs.

Note: These spindles are setup for 1973-1987 HD Rotor and Caliper. The HD Rotor is 1 1/4" wide.



Spindle Installation

Notes:

This spindle will not work with drum brakes.

A 7/16-14 bolt can be threaded into the spindle and used as an adjustable steering stop.

Instructions:

1. Remove the outer tie rods from the original spindles.
2. Trucks that are reusing existing 1973-1987 heavy half ton 1-1/4" thick rotors and calipers will need to remove the disc brake assemblies from the spindles. Trucks that are not reusing the existing brakes need to disconnect the brake hose from the brake line.
3. Remove the upper and lower ball joints from the spindle.
4. Remove the old spindles.

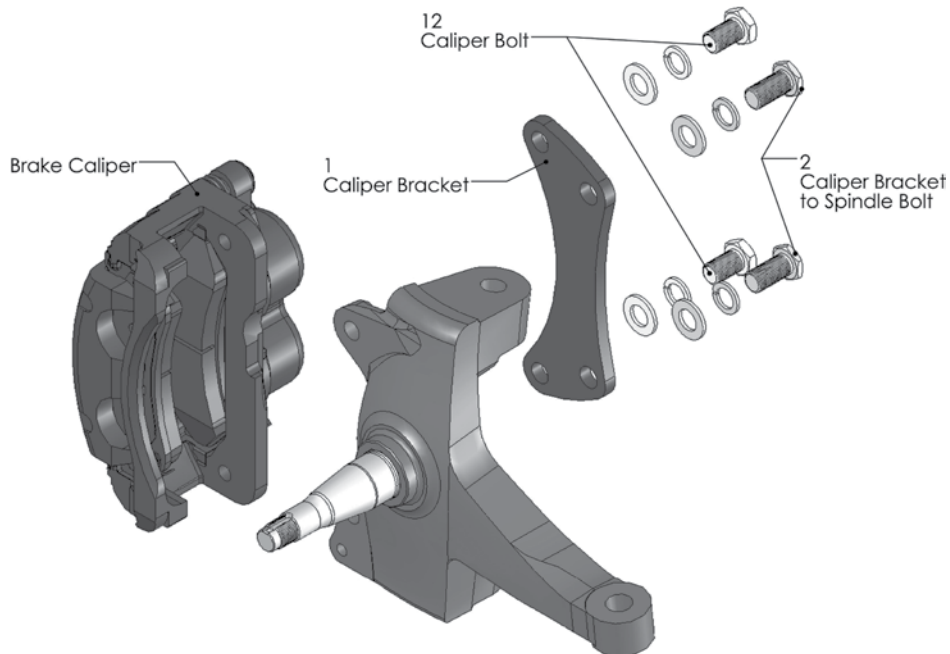

5. Install the new drop spindles onto the upper and lower ball joints.
6. Install the outer tie rods into the new spindles.
7. Install the caliper brackets. The supplied caliper brackets are designed to utilize 1973-87 heavy half ton 1-1/4" thick rotors and calipers. The brackets will mount to the inboard side of the spindle.
8. Pack the wheel bearings with grease. Install the inner bearings and the grease seal. Install the rotor/hub assembly. Install the outer wheel bearing, washer and spindle nut. Adjust the wheel bearings as follows:
 - a. Tighten the nut only slightly (no more than 12lb/ft.) spin the rotor in a forward direction to ensure the bearings are fully seated.
 - b. Check that the spindle nut is still tight. If not repeat step a.
 - c. Loosen the spindle nut until it is just loose.
 - d. Hand tighten the spindle nut and install the cotter pin. Do not use a wrench! If necessary loosen the nut to the first position the cotter pin can be installed into.
9. Install the caliper assemblies. The bleed screws will be towards the top.
10. If using new calipers connect the brake hose to the calipers and the frame. Bleed the brakes. Check for leaks.
11. Check that the rotor can turn freely and that the brakes do not drag.
12. Have the truck professionally aligned.



Part # 11369120 - 1963-1987 C10 Front Sway Bar



Recommended Tools



1963-1987 C-10 Front Sway Bar Installation Instructions

Table of contents

Page 2..... Included Components and Hardware List

Page 3..... Sway Bar Installation

Page 4..... Sway Bar Installation

Page 5..... Sway Bar Installation

Hardware Torque Specifications

3/8"-16..... 30 ftlbs

Major ComponentsIn the box

Part #	Description	QTY
90001246	Front Sway Bar	1
90002926	End Link Kit - SHORT - <i>Stock Control Arms</i>	1
90001346	Bushing Strap	2
70015016	Lined Sway Bar Bushing	2
90002591	Frame Mount	2
90002593	Control Arm Mounts	2
90002932	End Link Kit - LONG - <i>Ridetech Tubular Control Arms</i>	2

HARDWARE KIT.....99010089

QTY	Part #	Description	QTY	Part #	Description
FRAME MOUNT			BUSHING STRAP continued		
4	99371005	3/8"-16 x 1 1/4" Hex Bolt	4	99372001	3/8"-16 Nylok Nut
8	99373002	3/8" Flat Washer	CONTROL ARM MOUNT		
4	99372001	3/8"-16 Nylok Nut	4	99371005	3/8"-16 x 1 1/4" Hex Bolt
BUSHING STRAP			8	99373002	3/8" Flat Washer
4	99371005	3/8"-16 x 1 1/4" Hex Bolt	4	99372001	3/8"-16 Nylok Nut
8	99373002	3/8" Flat Washer			

Getting Started.....

This sway bar kit utilizes a anti-friction lining in the sway bar bushing. The lining allows the sway bar to move freely and quietly in the bushing. No lubrication is required.

This sway bar will fit 63-66, 67-72 & 73-87, but the installation varies between the 3 eras. Be sure that you are reading the instructions for the correct era of truck.

1. Jack the vehicle up to a safe working height and support with jack stands. Make sure the jack stands are stable before working under the truck.
2. If the truck is equipped with a stock swaybar, remove it.

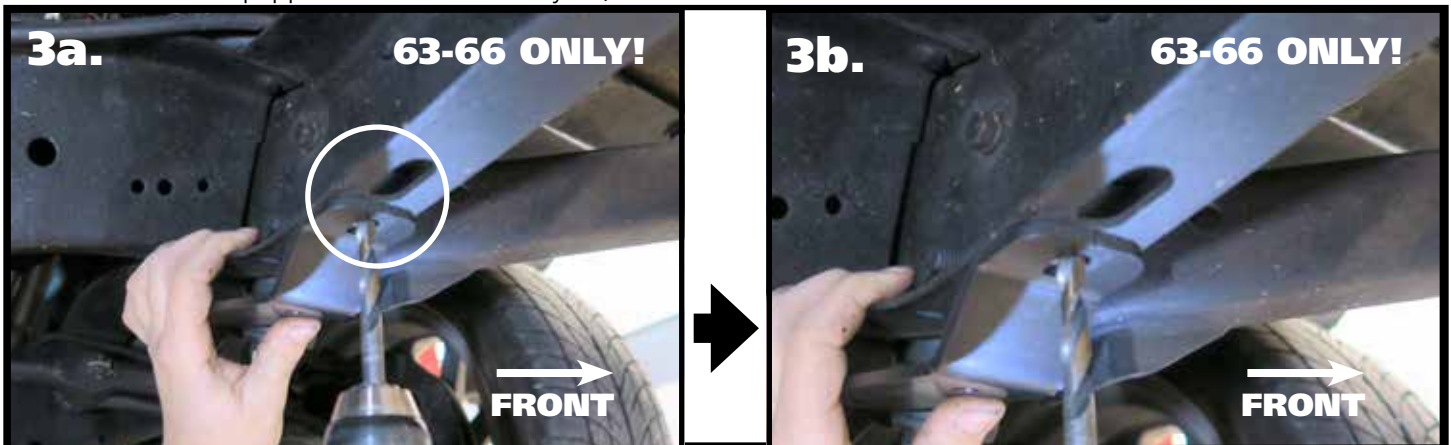

63-66 ONLY! 3a & 3b. The mounting holes for the frame mount will need to be drilled. The frame mount will attach to the frame with the ANGLED END FORWARD. The front edge of the frame mount will be aligned with the rear edge of the slot in the frame that is forward of the cross member. Hold the frame mount on the center on the frame with the front edge lined up with the rear edge of the slot. Use the frame mount as a template to mark the holes to be drilled. Drill the holes using a 3/8" drill bit. Attach the bracket using a 3/8"-16 x 1 1/4" bolt, 3/8"-16 nylok nut and a 3/8" flat washer on top and bottom. The same hardware setup is used in each hole. Repeat on the other side and torque hardware. **SKIP TO STEP 9.**



4. Remove the rivet from the bottom of the frame rail. This can be done by cutting the rivet head off and driving it out or by drilling it out. This cross member is located in front of the suspension cross member.



5. Attach the rear hole of the frame mounting bracket to the frame using the rivet hole. The end of the frame bracket with the angled bends goes forward. Attach the bracket using a 3/8"-16 x 1 1/4" bolt, 3/8"-16 Nylok nut and a 3/8" Flat Washer on top and bottom.



6. With the rear hardware installed, line up the bracket parallel with the frame rail. Use the front hole as a guide to drill a 3/8" hole in the frame.



7. Attach the front of the bracket using a 3/8"-16 x 1 1/4" bolt, 3/8"-16 Nylok nut and a 3/8" Flat Washer on top and bottom. Repeat on the other side and tighten hardware. **SKIP TO STEP 9.**

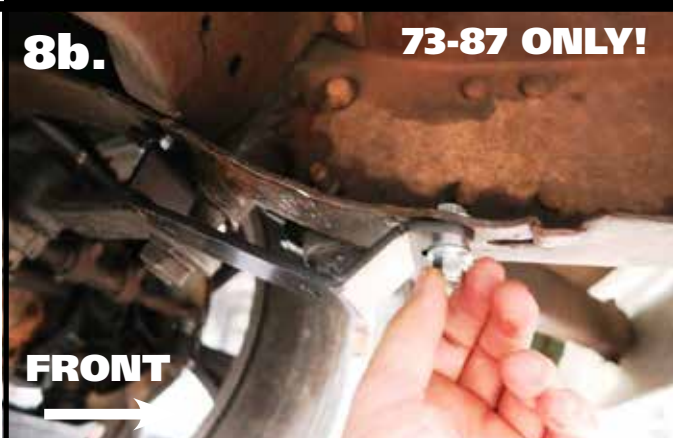

73-87 ONLY! 8a & 8b. If your truck is equipped with an OEM sway bar, the OEM mount will need to be removed to install the Ridetech sway bar. This is done by removing the rivets. The rivets can be removed by chiseling the heads off and driving them out or by drilling the rivets out. The new frame mount bolts directly in place of the old mount. If your truck doesn't have a sway bar, the mounting holes will still be in the frame. The sway bar mount attaches to the frame using the holes from the OEM mount. The end of the frame bracket with the angled bends goes forward. Attach the bracket using a 3/8"-16 x 1 1/4" bolt, 3/8"-16 nylok nut and a 3/8" flat washer on top and bottom. The same hardware setup is used in each hole. Repeat on the other side and torque hardware.

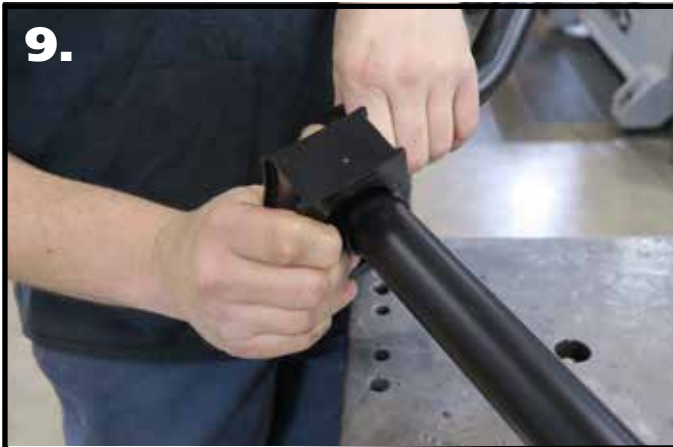

9.

9. Open the sway bar bushing at the split and slide it **OVER** the swasy bar. Do this for both bushings.



10.

10. Next, slip the bushing straps over the sway bar bushings.



11a.



11b.

11a & 11b. This kit requires a bracket to be installed on the control arm for the sway bar linkage. The bracket needs to be positioned with the inside edge 8 1/4" from the CONTROL ARM BUSHING and the ears pointing DOWN. Hold the end of the tape measure against the outer edge of the control arm bushing and make a mark on the control arm at 8 1/4". Hold the bracket on the control arm with the ears pointing DOWN and against the lip of the control arm. Use the bracket to mark and drill the mounting holes to 3/8". Install a 3/8" flat washer on (2) 3/8"-16 x 1 1/4" hex bolts and insert them into the holes. Install a 3/8" flat washer and 3/8"-16 nylok nut on each Bolt. Repeat on the other side and torque hardware.



12a.



12b.

12a & 12b. Hold the sway bar into position on the truck with the sway bar arms below the tie rods. Align the holes in the bushing straps with the holes in the frame brackets. Install a 3/8" flat washer on (4) 3/8"-16 x 1 1/4" hex bolts and insert them into the holes. Install a 3/8" flat washer and 3/8"-16 Nylok Nut on each bolt. Center the bar in the bushings before snugging up the hardware. Do **NOT** completely tighten the hardware. It will be left partially loose until the end links are installed.

13a & 13b. This kit includes 2 different lengths of end links. The SHORT end links are used for STOCK control arms. The LONG end links are used on STRONGARM installations.



13a. STOCK CONTROL ARMS Install the SHORT end links using **Diagram 1** as a reference. Install both end links before tightening the end link hardware. Tighten the end link barrel nut until it is flush with the end of the bolt, and then tighten it 2-3 more complete rounds.



13a. RIDETECH TUBULAR CONTROL ARMS Install the LONG end links using **Diagram 1** as a reference. Install both end links before tightening the end link hardware. Tighten the end link barrel nut until it is flush with the end of the bolt, and then tighten it 2-3 more complete rounds.

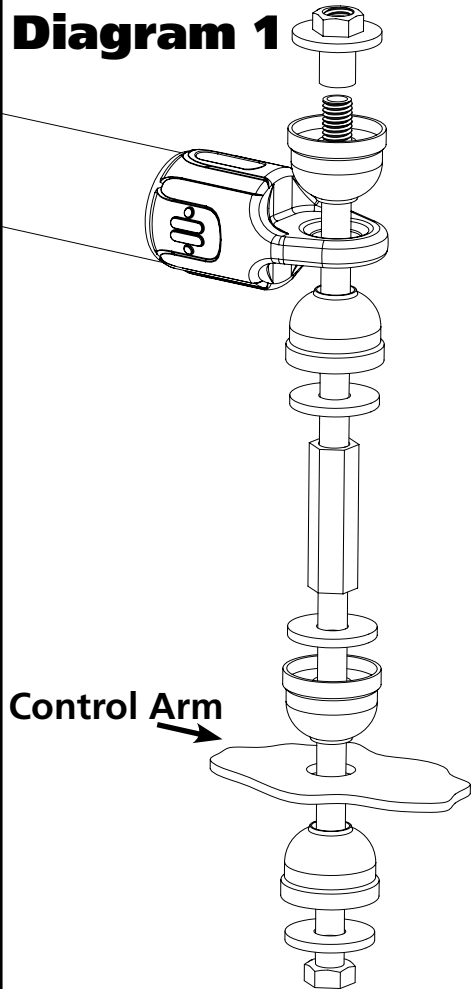

Tighten the end link barrel nut until it is flush with the end of the bolt, and then tighten it 2-3 more complete rounds.



9. Torque the sway bar mounting hardware to 30 ftlbs.



Part # 11367199 - 1973-1987 C10 Rear 4Link



Recommended Tools

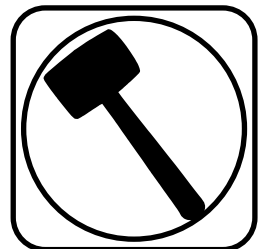

1973-1987 C-10 Rear 4Link Installation Instructions

Table of contents

- Page 25-26.... Included Components
- Page 27..... Hardware List & Getting Started
- Page 28..... Disassembly
- Page 29..... "C" Notch Installation
- Page 30..... Upper Cross Member Installation
- Page 31..... Frame Mount & Axle Mount Installation
- Page 32..... Installing Lower Axle Mount & 4Link bars
- Page 33..... Installing Panhard bar and Shockwave/CoilOvers
- Page 31..... Finishing



Major ComponentsIn the box

Item #	Part #	Description	QTY
1	90000668	Upper Crossmember	1
2	90000670	Driver C-Notch	1
3	90000671	Passenger C-Notch	1
4	90002746	Driver Lower Axle Bracket	1
5	90002748	Passenger Lower Axle Bracket	1
6	90000952	Panhard Bar - Set to 33 1/2"	1
7	90000673	Upper Axle Bracket	2
8	90000666	4Link Frame Mount - Driver	1
9	90000667	4Link Frame Mount - Passenger	1
10	90002824	4Link Bars - Set to 26 1/2"	4
11	90001318	R-Joint Rod End	5
12	90001086	Panhard Bushings - Pressed into Panhard Bar Frame End	2
	70013882	Panhard R-Joint Spacers - .625" ID x .740" Long	2
	90002895	Panhard Bushing Inner Sleeve - pressed into 90001086	1
	70013334	4Link Bar R-Joint Spacer .625" ID x .620" Long	16
	70013495	U-Bolt - 5/8-18 x 3.13 x 5.75 (Not Shown)	4
	99752004	3/4"-16 Jam Nut - Installed on Bars	5
	70013322	Short Bumpstops with Hardware	2
R-Joint Components - (Installed in bar ends)			
	70013279	Retaining Ring	4
	70013280	Wavo Wave Spring	4
	70013275	R-Joint Center Ball	4
	70013276	R-Joint Composite Center Ball Cage	4



Major ComponentsIn the box

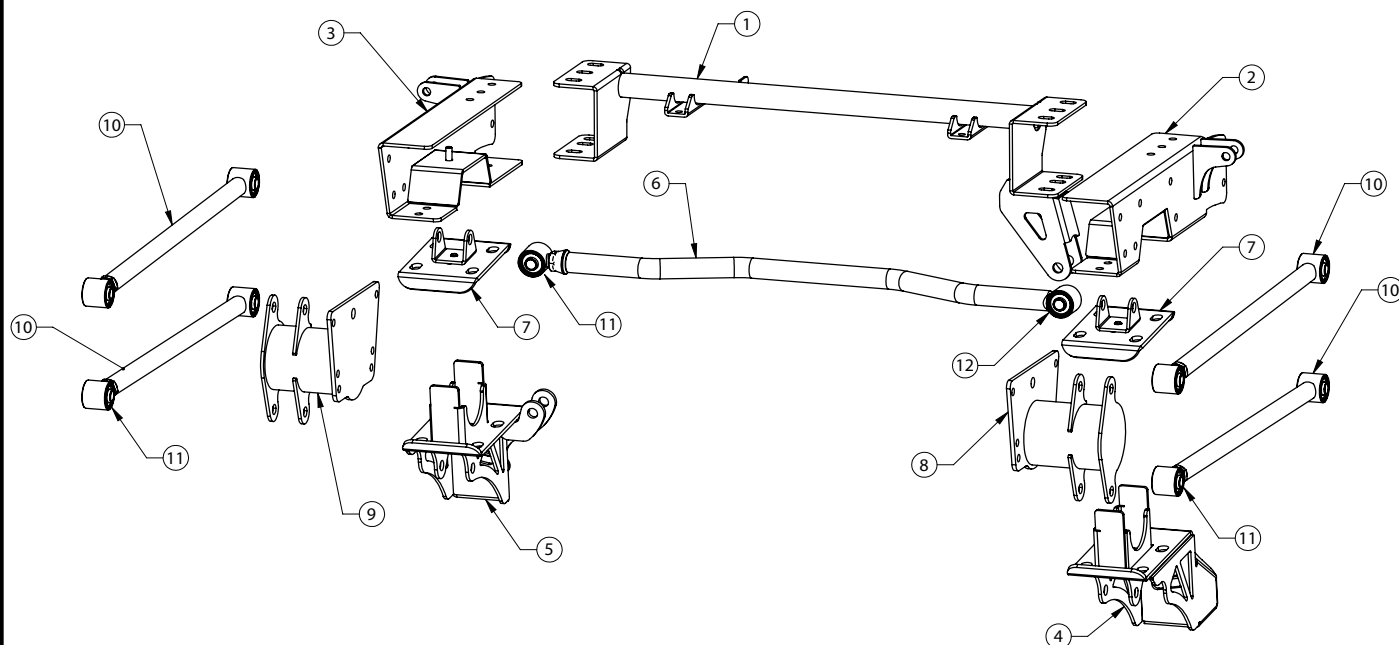

R-JOINT SPACER INSTALLATION

Install the Spacers by inserting the SMALL side of the SPACER into the Center Pivot Ball. Push them in until they bottom out and stop.

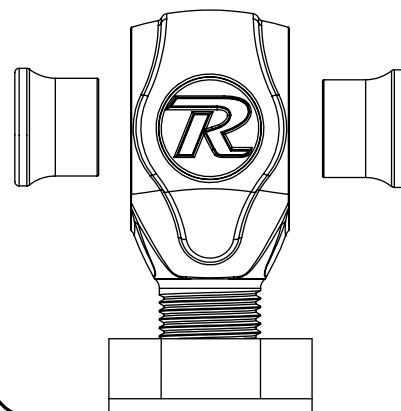



Hardware ListIn the box (Kit# 99010014)

The Hardware Kit contains bags to help aid in selecting the correct hardware for the component being installed. The hardware list shows how the hardware is bagged.

QTY	Part Number	Description	QTY	Part Number	Description
4LINK BARS			"C" NOTCH MOUNTING - REAR TOP & BOTTOM		
8	99621004	5/8" x 3" SAE Gr. 8 Bolt	12	99431008	7/16" x 1 1/2" USS Bolt
8	99622006	5/8" SAE Nylok Jam Nut	12	99432001	7/16" USS Nylok Nut
16	99623001	5/8" SAE Flat Washer	24	99433002	7/16" SAE Flat Washer
PANHARD BAR			BRAKE LINE BRACKET		
2	99621018	5/8" x 3 1/4" SAE Gr. 8 Bolt	1	99311002	5/16" x 1 1/4" USS Bolt
2	99622006	5/8" SAE Nylok Jam Nut	1	99312003	5/16" USS Nylok Nut
4	99623001	5/8" SAE Flat Washer	2	99313002	5/16" SAE Flat Washer
FRONT 4LINK BAR MOUNT			SHOCK MOUNTING		
12	99431002	7/16" x 1 1/4" USS Bolt	4	99501050	1/2" x 2 1/2" USS Bolt Gr. 8
24	99433002	7/16" SAE Flat Washer	4	99502009	1/2" USS Nylok Nut Gr. 8
12	99432001	7/16" USS Nylok Nut	8	99503012	1/2" SAE Flat Washer Gr. 8
AXLE BRACKET TO AXLE			BUMP STOP		
8	99622001	5/8" SAE Nylok Nut	2	99373003	3/8" SAE Flat Washer
16	99623001	5/8" SAE Flat Washer	2	99372002	3/8"-16 Nylok Nut
"C" NOTCH MOUNTING - SIDE & FRONT LOWER					
24	99431002	7/16" x 1 1/4" USS Bolt			
24	99432001	7/16" USS Nylok Nut			
48	99433002	7/16" SAE Flat Washer			

Hardware Notes

The Hardware Kit contains bags to help aid in selecting the correct hardware for the component being installed. The hardware list shows how the hardware is bagged, but care must be taken to make sure you are installing the correct length bolts in the correct location. The kit contains (8) 5/8" -18 x 3" bolts for the 4 link bars and (2) 5/8"-18 x 3 1/4" bolts for the panhard bar. These bolts are very close in length and very easily mistaken for each other. If you are unsure of which one you have in your hand, use a tape measure to verify. Hex bolts are measured by measuring from the BOTTOM of the hex to the end of the threads. The hex area of the bolt is NOT part of the bolt length.



Disassembly

Congratulations on your purchase of the Ridetech Rear 4Link System. This system has been designed to give your truck excellent handling along with a lifetime of enjoyment. Some of the key features of this system: C-notches to give your suspension the travel it needs at the lowered height, 4Link setup to replace the leaf spring, this provides better control of the rear axle, long panhard bar to reduce the side-to-side movement of the differential, and the biggest feature of all, it allows the use of Shockwaves or CoilOvers.

Note: This system is designed for use with the Ridetech Shockwaves or CoilOvers and the MuscleBar swaybar. **The factory shocks and springs or the factory sway bar will not fit this 4Link.**

1. Raise the vehicle to a safe and comfortable working height and support it by the frame. You will need to be able to move the rear differential up and down. Let the rear suspension hang freely.
2. **Remove the bed.**
3. Raise the axle a couple inches and support it so that it cannot rotate. Remove the leaf springs and shock absorbers. Refer to the factory service manual for proper disassembly procedures.



4. The Brake Line Bracket will need to be removed from the passenger side frame rail. This will require separating the steel line from the rubber line at the bracket. There is a provision for the brake line in the upper bridge of the 4 link kit. Cap the line off to help prevent the brake fluid from draining out of the line. Remove the bracket by removing the rivets. We like to use a die grinder to cut a "+" in the head of the rivet. We then knock the head off with a hammer and chisel or an air chisel. With the head removed, knock the rivet out of the bracket and frame.

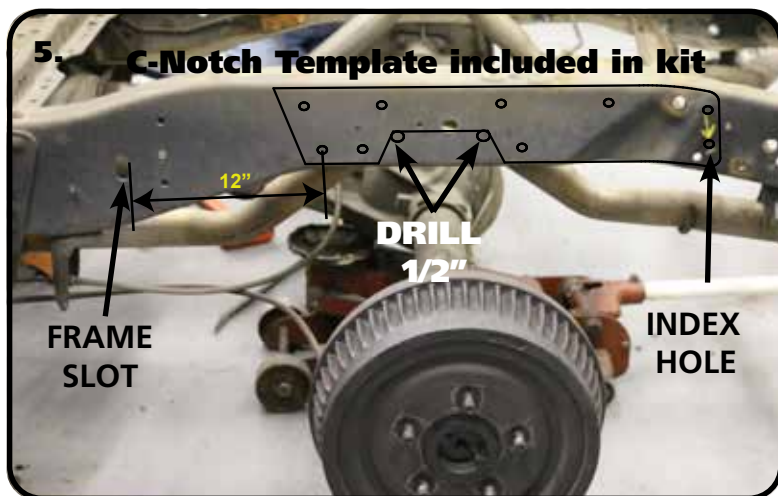

5. To allow maximum drop on this truck the frame must be notched. The template for the notch will locate off of the index hole shown below. Use the supplied "C" Notch template to mark out the frame for cutting. Before cutting out the frame, support the frame in front of and behind the "C" Notch area. We suggest doing one side at a time. The "C" Notch template has an arrow pointing to the front of the truck. Use the "Index Hole" in the back side of the template to help locate the Template. FOR TRUCKS THAT DO NOT HAVE THE INDEX HOLE, THE CENTER OF THE FRONT LOWER MOUNTING BOLT IS 12" FROM THE BACK EDGE OF THE FRAME SLOT.



"C" Notch Installation



6. Use the supplied Template to mark the cut lines on the frame, then drill out the two corners with a 1/2" drill bit. This will give the cut a round edge and eliminate the possibility for stress fractures. Then cut the notch with a saw-z-all, cutoff wheel or plasma cutter. Grind all edges smooth.



7. Slide the C-Notch in place making sure the "Index Hole" is aligned. If it doesn't align, you may need to trim the C-Notch opening you cut in the frame. Once you have the C-Notch fitting properly, use it for a template to drill the attaching holes in the frame. Drill the holes in the side of the frame and also the top and bottom of the frame. Use a 7/16" drill bit to drill these. You will have to drill out the "Index Hole" to 7/16" too. Install a 7/16" Flat Washer onto (12) 7/16"-14 x 1 1/4" bolts. Insert the bolts/washers into the drilled holes leaving the bolts out of the rear 3 holes on the top and bottom of the C-Notch. Install a 7/16" Washer and 7/16" Nylok Nut on each of the bolts sticking through the frame and tighten to 50 ftlbs. Repeat steps 5-7 on other side.



8. Install the bumpstops into the "C" Notches using a 3/8" nut and flat washer. Tighten the hardware enough to hold the bumpstop in place.



Upper Cross Member Installation



9. After both C-Notches have been installed, the Upper Cross Member can be installed. The Cross Member is located using the rear 3 holes in the top and bottom of each C-Notch. The Panhard bar mount is located on the driver's side of the Cross Member. The Cross Member attaches underneath the Frame on the top, and underneath the C-Notch on the bottom. Install a 7/16" Flat Washer on (12) 7/16" x 1 1/2" Hex Bolts and insert them into each of the (12) holes. Install all of the bolts with the Nylok Nuts inside the frame. Install a 7/16" Flat Washer & 7/16" Nylok Nut on each of the (12) Bolts and tighten to 50 ftlbs.



10. Attach the rubber brake line to the Upper Cross Member using the OEM clip. You may have to tweak the steel brake line to reposition it to thread into the rubber brake line. Thread the steel brake line into the rubber brake line and tighten.

YOU WILL NEED TO BLEED THE REAR BRAKES BEFORE DRIVING THE TRUCK!!



11. The OEM front leaf spring mounts will need to be removed from the frame rail. This can be done by either drilling the rivets out or removing the rivet heads and driving them out. We remove the rivet heads by cutting a " + " in the head with a die grinder then we cut the head off with a hammer and chisel or with an air chisel. Once the head is removed, the rivet can be driven out with a hammer and punch. After removing the frame mounts, drill the rivet holes with a 7/16" drill bit.



Frame Mount & Axle Mount Installation



12. The Bar Mounts bolt in place of the OEM front leaf spring mount. There is a Driver and Passenger Mount. **Image 12** shows the Driver Mount. The Tabs are to the FRONT of tube. Install a 7/16" Flat Washer on (6) 7/16" x 1 1/4" Bolts. Hold the Mount in place and insert the bolts/washer through the mount and frame. Install a 7/16" Flat Washer and 7/16" Nylok Nut on each bolt sticking through the frame and tighten to 50 ftlbs. Repeat on the other side.

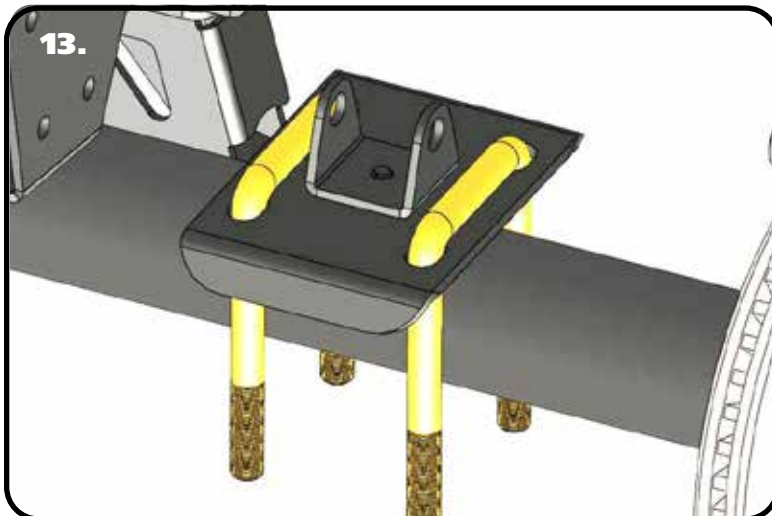

13. The Kit includes 2 Upper Bar Mounts that are the same. Each one sits on a leaf spring pad with the center pin indexed into the center hole of the leaf spring pad. Sit an Upper Bar Mount on top of the axle with the locating pin into the center hole of the leaf spring pad. Install a 5/8" Square U-bolts through each pair of side holes in the Upper Bar Mount with the threads pointing down. The U-bolts will run parallel to the frame.



14. The Kit includes a Driver and Passenger Lower Axle Mount; the two are different. The Passenger Mount has the Panhard bar mount built into it. Image 13 shows the Driver Mount. Hold the Mount up in place against the bottom of the axle tube. The tabs will nest against the bottom of the leaf spring pad. Make sure the u-bolts drop through the holes in the Lower Mount. Install a 5/8" Flat Washer followed by a 5/8" Nylok Nut on each leg of the U-Bolts. Tighten the Nuts evenly until the Lower Mount is tight against the tube and leaf spring pad. Then torque the Nuts to 60 ftlbs in a crisscross fashion.



Installing Lower Axle Mount & 4Link Bars

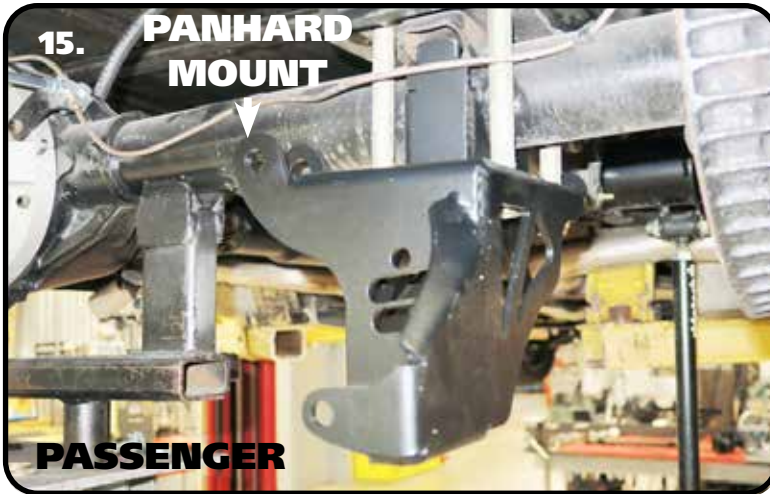

15. Repeat the above step on the Passenger Lower Mount. Torque the hardware to 60 ftlbs in a crisscross fashion.



16. This Kit contains (4) 4Link bars that are the same. **Insert the R-Joint Spacers into the Center Pivot Ball of the R-Joints in the bars as shown on Page 3.** Each Bar is attached with a **5/8" x 3" Bolt**, 5/8" Nylok Jam Nut, & (2) 5/8" Flat Washers. Install a 5/8" Flat Washer on each of the **5/8" x 3" Bolts**. Attach the front of the bars to the frame mounts first. Do this by holding the Bar in position and insert the 5/8" Bolt/Washer through the Mount and Bar End. Install a 5/8" Flat Washer followed by a 5/8" Nylok Jam Nut on the threads of the bolt. Install all of the Bars before tightening the Hardware.



17. Attach the rear of the Bars to the Axle Mounts. The upper bar gets installed in the Upper Axle Bracket, the lower bar gets installed in the Lower Axle Bracket. Each Bar is attached using (1) **5/8" X 3" Bolt**, (2) 5/8" Flat Washer & (1) 5/8" Nylok Jam Nut. Install a 5/8" Washer on each Bolt before inserting them through the Bar/Bracket. Install a 2nd 5/8" Flat Washer on the threads of the bolt that are sticking out of the bracket followed by a 5/8" Nylok Nut. Tighten the hardware enough to eliminate any gaps.



Installing Panhard Bar and Shockwaves/Coilovers



18.

18. Install the Panhard bar into the frame bracket. The Panhard Bar is a bent bar, it is bent to clear the center section of the rear differential. The bar needs to be mounted with the BEND to the REAR and the Rubber Bushing in the Frame Mount, this will help it clear the differential cover. The Panhard bar is attached using (1) **5/8" x 3 1/4" bolt**, (1) 5/8" Nylok Jam Nut & (2) 5/8" Flat Washers. Tighten the hardware enough to eliminate any gaps.

Note: The panhard bar is set at 33 1/2" before it is shipped, but may need adjusted to center the axle at ride height.



19.

19. Install the .740" Long R-Joint Spacers into the Center Pivot Ball of the R-Joint in the Panhard Bar. Install the other end of the Panhard bar into the mount on the Passenger Lower Axle Mount. The Panhard bar is attached using (1) **5/8" x 3 1/4" bolt**, (1) 5/8" Nylok Jam Nut & (2) 5/8" Flat Washers. Tighten the hardware enough to eliminate any gaps.

20. Insert a Spacer into each side of the upper Shockwave/CoilOver bearing. Slide the assembly into the upper shock mount. If your shock has an adjuster knob, position it so that the knob points toward the outside of the truck. Line up the hole in the spacers with the hole in the upper shock mount and insert 1/2" x 2 1/2" bolt and 1/2" Nylok nut with a 1/2" SAE Flat Washer on each side of the mount.

Note: If installing Shockwaves and you want to locate the air fitting in a different location, the air spring assembly can be rotated on the shock by grabbing the shock and air spring assembly by hand and spinning the shock in the air spring assembly.



20.

SPACER



Finishing

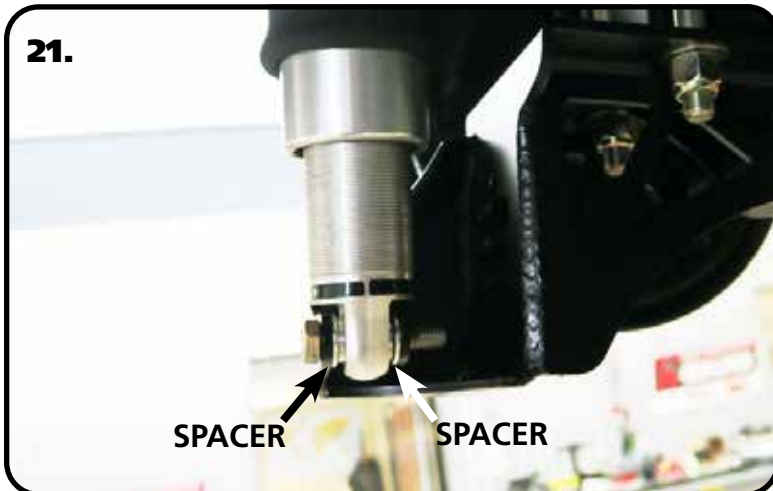

21. Insert a Spacer into each side of the lower Shockwave/CoilOver bearing. Slide the shock, with the spacers installed, into the mount on the Lower Axle Mount. You may need to jack the rearend up to line up the holes in the bushings with the 1/2" hole in the shock mounts and hold it in place while you install the 1/2" x 2 1/2" Bolt and 1/2" Nylok Nut with a 1/2" SAE Flat Washer on each side of the mount. Tighten the upper and lower shock bolts to 75 ftlbs.

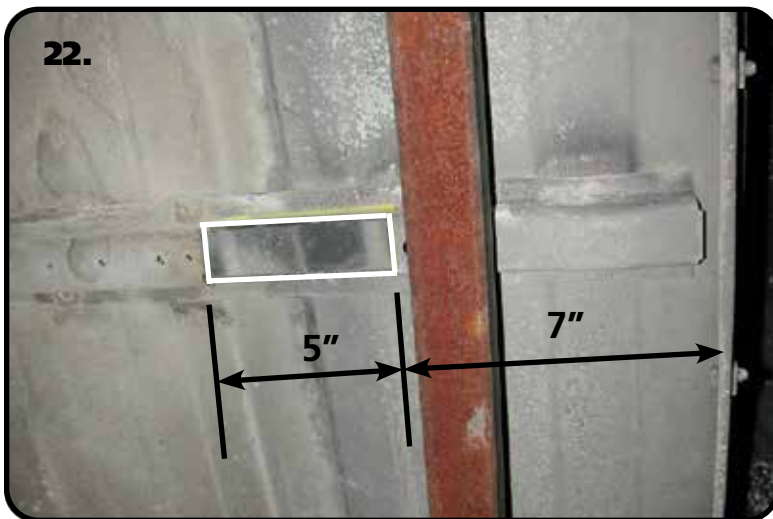

22. To allow clearance for the C-Notch, a section of the bed floor brace that is above the axle must be removed. This section is approximately 5" wide and about 7" from the fender well.

23. Tighten all fasteners. If you are going to install the Ridetech MuscleBar, now is a good time to do it. Reinstall the bed and set the truck back on the ground.

24. Set ride height on the truck. The ride height of the Shockwave/CoilOver is approximately 14 1/2". If you are using Shockwaves, this is done by changing the air pressure in the Shockwaves. If you are using CoilOvers, the ride height is done by using the adjuster nut for the coil spring. The coil spring on the CoilOver will have some preload in the spring to get ride height, this is normal.

25. Measure to make sure the axle is centered at ride height. We prefer to measure between the frame and wheel. Make sure you are measuring the truck in the same location on both sides. If the measurements are off more than 1/16", adjust the Panhard Bar to center the differential.

BLEED THE REAR BRAKES!!!



Part # 11366511 - 1973-1987 C10 Rear CoilOvers

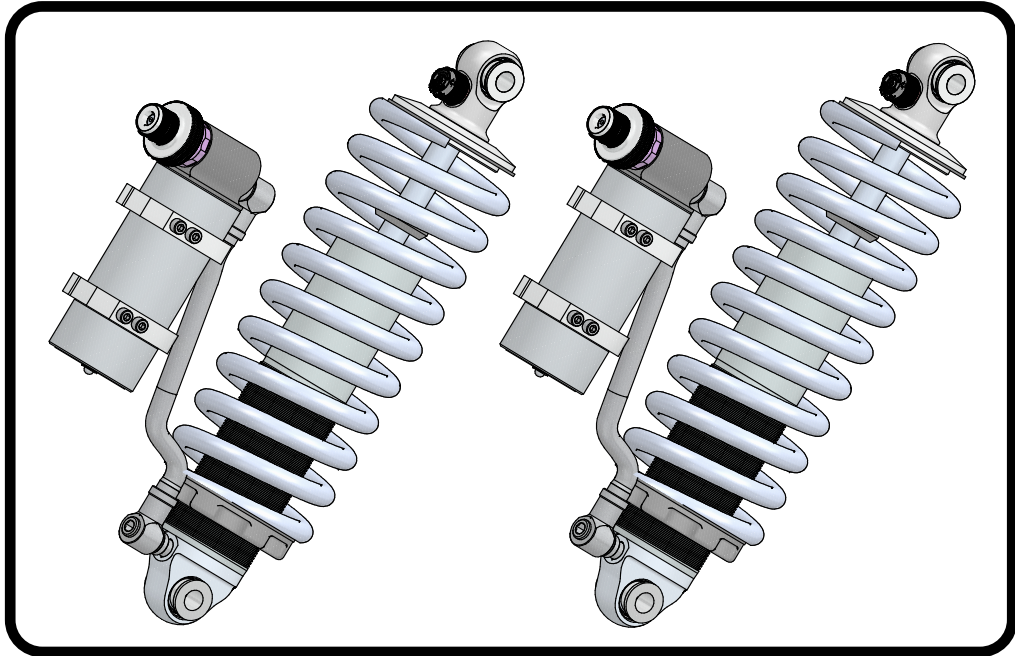

Recommended Tools

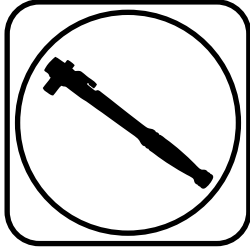

1973-1987 C-10 TQ Series Rear Coilovers Installation Instructions

Table of contents	
Page 36.....	Included Components
Page 37-38.....	Assembly and Adjusting
Page 39.....	Shock Adjustment and Setting Height



Major ComponentsIn the box

Item #	Part #	Description	QTY
1	986-10-072	5.2" Stroke TQ Series Shock	2
2	815-05-022-KIT	1.7" Shock Eyelet	2
3	803-00-199(kit)	Upper Coilspring Mount	2
4	59100225	Coilspring 10" 225lb	2
5	70010828	Delrin Spring Washer	4
6	803-00-199(kit)	Lower Spring Adjuster Nut (803-00-199 kit)	2
	803-00-199(kit)	Adjuster Nut Locking Screw (803-00-199 kit)	2
	803-00-199(kit)	Retaining Ring (803-00-199 kit)	2
9	026-05-000	Reservoir Clamps	4
10	99050000	Reservoir Socket Head Cap Screws	12
11	90001994	5/8" ID Bearing (installed in shock and eyelet)	4
12	90001995	Bearing Snap Ring (installed in shock and eyelet)	8
	90002043	1/2" ID Bearing Spacer Half - NOT SHOWN	8

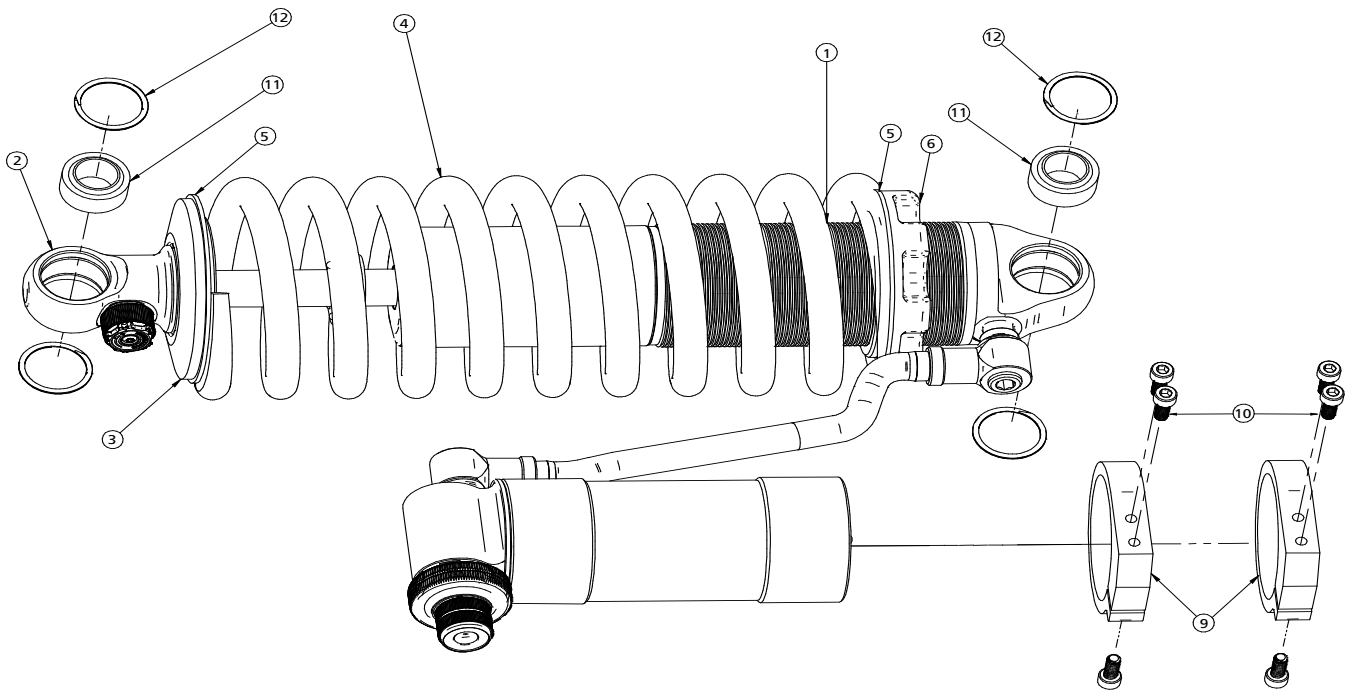

CoilOver Assembly...



1

First, using the supplied lower adjuster nut (803-00-199) thread the nut onto the shock from the bottom side as seen in figure 1. Remove the plastic pellet that is in the split of the adjuster nut.



4

Once the knob is removed slide a Delrin washer over the eyelet. Next, slide the upper spring mount (803-00-199) over eyelet as seen in figure 4.



2

Next, install a delrin washer then coil spring over the top of the shock as seen in figure 2.



5

Install upper spring mount retainer clip (803-00-199) into the groove on the upper eyelet as seen in figure 5. Then, reinstall adjuster to complete assembly.



3

Before the upper spring mount can be installed screw the adjuster knob on the upper eye mount to the firmest setting (clockwise) as seen in figure 3. Then remove the Knob by holding it while removing the center screw.

Install the locking screw in the adjuster nut before setting spring preload, but DO NOT tighten until the spring preload has been set.

NOTE: Remember to adjust the shock valving before driving, the shock is currently set to full stiff.

Shock Adjustment 101- Single Adjustable

Rebound Adjustment:

How to adjust your new shocks.

The rebound adjustment knob is located on the top of the shock absorber protruding from the eyelet.

You must first begin at the ZERO setting, then set the shock to a medium setting of 12.



-Begin with the shocks adjusted to the ZERO rebound position (full stiff). Do this by rotating the rebound adjuster knob clockwise until it stops.



-Now turn the rebound adjuster knob counter clock wise 12 clicks. This sets the shock at 12. (settings 21-24 are typically too soft for street use).

Take the vehicle for a test drive.



-if you are satisfied with the ride quality, do not do anything, you are set!

-if the ride quality is too soft increase the damping effect by rotating the rebound knob clock wise 3 clicks.

Take the vehicle for another test drive.



-if the vehicle is too soft increase the damping effect by rotating the rebound knob clock wise 3 additional clicks.



-If the vehicle is too stiff rotate the rebound adjustment knob counter clock wise 2 clicks and you are set!

Take the vehicle for another test drive and repeat the above steps until the ride quality is satisfactory.

Note:

One end of the vehicle will likely reach the desired setting before the other end. If this happens stop adjusting the satisfied end and keep adjusting the unsatisfied end until the overall ride quality is satisfactory.



Shock Adjustment

Shock Adjustment 101- Triple Adjustable

Triple Adjustable:

Step One: High Speed Compression



- High speed compression adjustments are used in both street driving and track tuning.
- Begin with the shocks adjusted to the ZERO high speed compression position (full stiff). Do this by rotating the high speed compression adjuster (large knob) clockwise until it stops.
- Now turn the high speed compression adjuster knob counter clock wise 20 clicks. This sets the shock at 20. (settings 21-24 are typically too soft for street use. For typical street driving the high speed compression adjuster will remain at setting 20.

Step Two: Low Speed Compression

Low speed compression adjustment is what is typically felt during street driving.



- Begin with the shocks adjusted to the ZERO low speed compression position (full stiff). Do this by rotating the low speed compression adjuster (small knob) clockwise until it stops.
- Now turn the low speed compression adjuster knob counter clock wise 20 clicks. This sets the shock at 20. (settings 21-24 are typically too soft for street use). Take the vehicle for a test drive.
- if you are satisfied with the ride quality, do not do anything, you are set!
- if the ride quality is too soft increase the damping effect by rotating the low speed compression knob clock wise 3 clicks.

Take the vehicle for another test drive.



- if the vehicle is too soft increase the damping effect by rotating the low speed compression knob clock wise 3 additional clicks.
- If the vehicle is too stiff rotate the low speed compression adjustment knob counter clock wise 2 clicks and you are set!

Take the vehicle for another test drive and repeat the above steps until the ride quality is satisfactory.

Step 3:

Adjust rebound according to Single Adjustable instructions.

Note:

One end of the vehicle will likely reach the desired setting before the other end. If this happens stop adjusting the satisfied end and keep adjusting the unsatisfied end until the overall ride quality is satisfactory.



Final Tightening and Adjusting

Ride Height

We have designed most cars to have a ride height of about 2" lower than factory. To achieve the best ride quality & handling, the shock absorber needs to be at 40-60% overall travel when the car is at ride height. This will ensure that the shock will not bottom out or top out over even the largest bumps. Measuring the shock can be difficult, especially on some front suspensions. Measuring overall wheel travel is just as effective and can be much easier. Most cars will have 4-6" of overall wheel travel. One easy way to determine where you are at in wheel travel is to take a measurement from the fender lip (center of the wheel) to the ground. Then lift the car by the frame until the wheel is just touching the ground, re-measure. This will indicate how far you are from full extension of the shock. A minimum of 1.5" of extension travel (at the wheel) is needed to ensure that the shock does not top out. If you are more than 3" from full extension of the shock then you are in danger of bottoming out the shock absorber.

Adjusting Spring Height

When assembling the CoilOver, screw the spring retainer tight up to the spring (0 preload). After entire weight of car is on the wheels, jounce the suspension and roll the car forward and backward to alleviate suspension bind.

- If the car is too high w/ 0 preload then a smaller rate spring is required. Although threading the spring retainer down would lower the car, this could allow the spring to fall out of its seat when lifting the car by the frame.
- If the car is too low w/ 0 preload, then preload can then be added by threading the spring retainer up to achieve ride height. On 2.6" - 4" stroke shocks, up to 1.5" of preload is acceptable. On 5-7" stroke shocks, up to 2.5" of preload is acceptable. If more preload is needed to achieve ride height a stiffer spring rate is required. Too much preload may lead to coil bind, causing ride quality to suffer.