



Part # 11360910

1973-1987 C10/C15 FRONT CoolRide for StrongArms w/ HQ Series Shocks



Recommended Tools

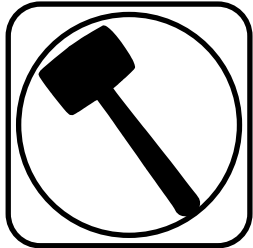

1973-1987 C10/C15 Front CoolRide Air Spring Kit Installation Instructions

Table of contents

- Page 2..... CoolRide Kit Components & Hardware List
- Page 3..... Getting Started
- Page 3-5..... Installing CoolRide
- Page 6..... Installing Shock
- Page 7..... Shock Adjustment

THIS COOLRIDE KIT IS DESIGNED TO BE USED WITH RIDETECH STRONGARMS.



CoolRide Kit ComponentsIn the box

Item #	Part Number	Description	QTY
1	90006873	8" Diameter Air Spring	2
2	90000060	Upper Air Spring Plate	2
3	90000472	Aluminum Bumpstop Extension	2
4	90000726	Bump Stop Plate - Driver	1
4	90000727	Bump Stop Plate - Passenger (Not Shown)	1
5	90001083	Medium Bumpstop	2
6	986-10-042	4.75" Stroke HQ Series Shock	2
7	70011138	3/4" ID Shock Bushing	2
8	90002102	1/2" ID x 1.312" Shock Sleeve	2
9	70011140	Shock Stem Bushings	4
10	70011141	Shock Stem Bushing Washers	4
11	90002303	Upper Shock Bracket - Driver	1
11	90002304	Upper Shock Bracket - Passenger (Not Shown)	1
12	90000471	Aluminum Shock Spacer	2
13	90001619	Lower Shock Bolt Kit	2
	85000020	5/64" Hex Wrench - Adjuster Knob Set Screw	1

CoolRide Hardware.....In the box

Item #	Part Number	Description	QTY	Item #	Part Number	Description	QTY
UPPER AIR SPRING MOUNTING				STEERING STOP			
14	99372002	3/8-16 Nylok Nut	12	15	99373003	3/8" SAE Flat Washer	2
15	99373003	3/8 SAE Flat Washer	20	17	99373005	3/8 Split Lock Washer	2
16	99371004	3/8-16 X 1 1/4" Hex Bolt	8	18	99371001	3/8"-16 X 3/4" Hex Bolt	2
LOWER AIR SPRING				SHOCK MOUNTING			
15	99373003	3/8 SAE Flat Washer	2	14	99372002	3/8-16 Nylok Nut	8
17	99373005	3/8 Split Lock Washer	2	15	99373003	3/8 SAE Flat Washer	16
18	99371001	3/8-16 X 3/4" Hex Bolt	2	16	99371004	3/8-16 X 1 1/4" Hex Bolt	8
				19	99372006	3/8"-24 Thin Jam Nut	4



CoolRide Kit ComponentsIn the box

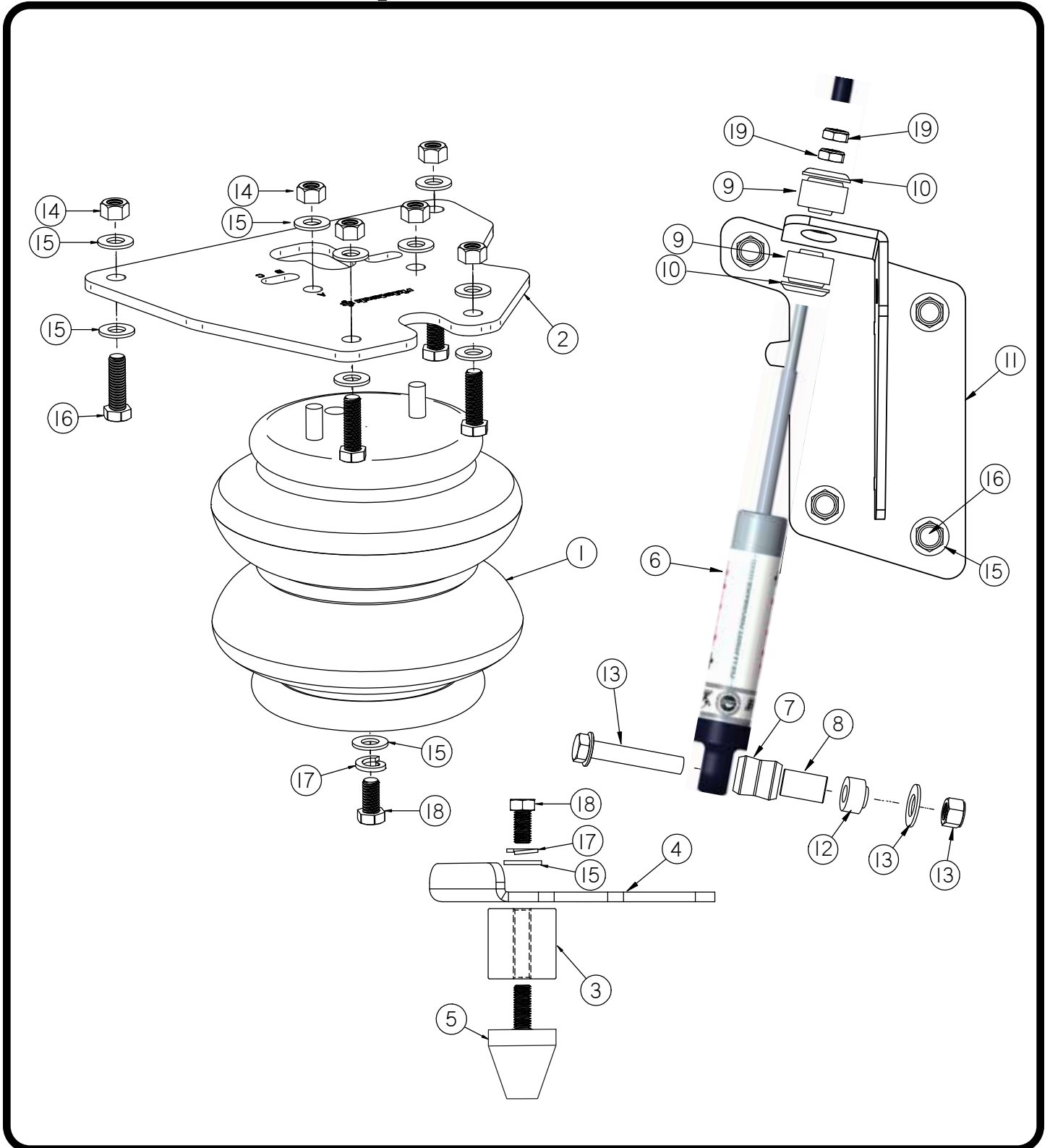



Getting Started.....

THIS KIT IS DESIGNED TO BE USED WITH RIDETECH STRONGARMS. INSTALL THE SHOCK KIT IN CONJUNCTION WITH THIS COOLRIDE KIT.

1. Raise and support truck at a safe, comfortable working height. Let the front suspension hang freely
2. Remove coil spring and shock absorber. Refer to factory service manual for proper disassembly procedure.
3. Apply thread sealant to the air fitting and screw it into the top of the air spring.

Installing CoolRide



- 4.** Hold the upper plate to the cross member as shown in the picture to the left and clamp to frame. Using the plate as a template drill 4 holes in the cross member.



- 5.** Apply thread sealant to the air fitting and thread into the air spring. Remove the upper plate from the frame and place onto the studs on the top of the air spring. The holes are lettered; slide the plate to position B moving the air spring to the rear of the vehicle. Secure with 3/8" flat washers and 3/8"-16 nyloc nuts Torque the nuts 15-20 ft-lbs. Route airline. Attach the air spring assembly to the frame using 3/8" x 1 1/4" bolts, Nylok nuts and flat washers supplied. Bolt the frame hardware to 23 ft-lbs.



Installing CoolRide



Note: It is acceptable to let the suspension bottom on the air spring. However, if your tire hits the inner fender well before the air spring bottoms out, this bump stop must be installed.

6. The bump stop plate will bolt to the outer two holes of the upper air spring plate. It will hang over the front side of the cross member. It is acceptable to trim the bump stop to achieve maximum drop without the tire rubbing the inner fender well. Torque the 3/8" hardware to 23 ft-lbs.



7. Bolt the bump stop spacer to the plate using a 3/8"-16 x 3/4" bolt, 3/8" split lock washer, & 3/8" flat washer. Torque to 12 ft-lbs. Thread the bump stop into the end of the spacer.



8. Fasten the air spring to the lower control arm using a 3/8" x 3/4" bolt, lock washer and flat washer. Torque the bolts to 23 ft-lbs.



Installing Shock



9. Place the new upper shock mount against the frame, the tab in the front of the bracket will slide into the factory shock stud hole. Position the bracket so that the bottom of the bracket is parallel to the bottom of the frame. Using the bracket as a template, mark an drill four 3/8" holes in the frame rail. Secure the bracket to the frame using four 3/8" x 1 1/4" bolts, Nylok nuts and flat washers. Torque the hardware to 23 ft-lbs.

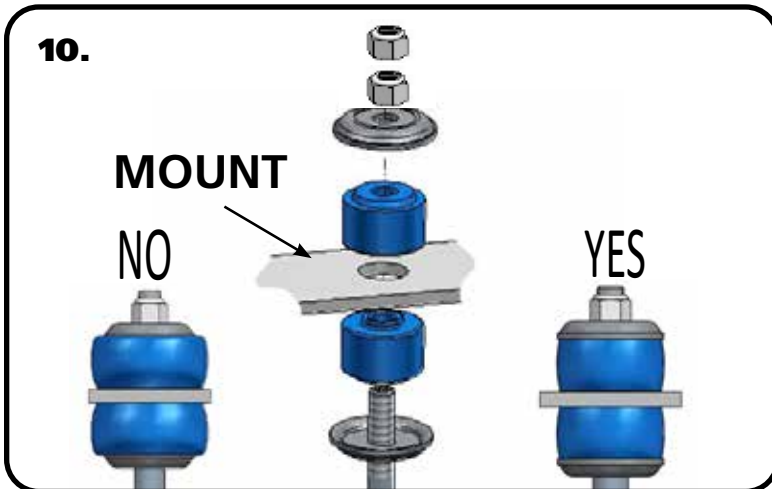

10. After the shock mounts are installed, install the Ridetech shock. Remove the adjuster knob by loosening the set screw using the supplied Hex Key. Install a Bushing Support Washer on to the shock shaft followed by a Shock Stem Bushing. Insert the assembly through the factory shock hole in the frame. With the shock stud sticking through the frame, install a Shock Stem Bushing on to the shock stud followed with a Bushing Support Washer. Install a 3/8"-24 Thin Jam nut onto the threads and tighten to 35 in-lbs. The Bushing should be tight, but not to the point that the bushing is bulging past the Support Washer. Install the 2nd 3/8-24 Thin Jam nut and tighten it against the first nut. Reinstall the Adjuster Knob, align the set screw with the FLAT side of the adjuster shaft that is sticking out of the top of the shock shaft.

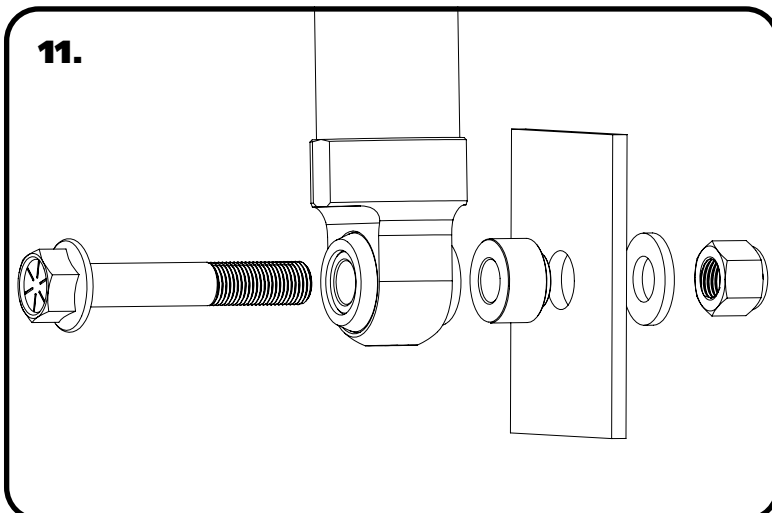

11. Insert the 1/2"-20 x 3" flanged head shock bolt through the lower shock eye and then place the aluminum spacer onto the stud. The step on the spacer will go into the arm. Slide the stud through the tab on the lower arm and secure w/ nut and washer. Torque to 75 ft-lbs.

Make sure that the air spring cannot rub on anything at anytime. This will result in air spring failure and is a not a warrantable situation.

Ride height on this air spring is approximately 5" tall, but may vary to driver preference.



Shock Adjustment

Shock adjustment 101- Single Adjustable

Rebound Adjustment:

How to adjust your new shocks

The rebound adjustment knob is located on the top of the shock absorber protruding from the eyelet or stud top. You must first begin at the ZERO setting, then set the shock to a street setting of 12 or handling setting of 8.

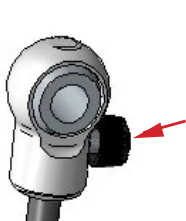

-Begin with the shocks adjusted to the ZERO rebound position (full stiff). Do this by rotating the rebound adjuster knob clockwise until it stops.

-Now turn the rebound adjuster knob counter clockwise 12 clicks. This sets the shock at 12 for a street setting. If you are after a handling setting only go 8 clicks.

Take the vehicle for a test drive.

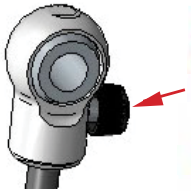

-if you are satisfied with the ride quality, do not do anything, you are set!

-if the vehicle is too soft increase the damping effect by rotating the rebound knob clockwise 3 additional clicks.

-If the vehicle is too stiff rotate the rebound adjustment knob counter clock wise 2 clicks and you are set!

Take the vehicle for another test drive and repeat the above steps until the ride quality is satisfactory.

Note:

One end of the vehicle will likely reach the desired setting before the other end. If this happens stop adjusting the satisfied end and keep adjusting the unsatisfied end until the overall ride quality is satisfactory.