

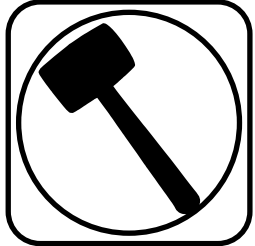

Part # 11369300 - 1973-1987 C10 HD Drop Spindles

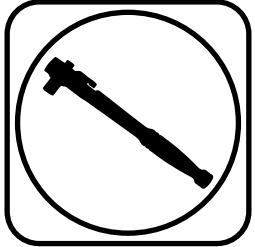

Recommended Tools



Major ComponentsIn the box

- 1 11369301 Pair of 73-87 drop spindles
- 1 90001926 Pair of caliper brackets

Hardware		
Qty	Part #	Description
4	99622038	5/8"-18 x 1.25" Bolt
4	99623002	5/8" Lock Washer
4	99623010	5/8" SAE Flat Washer

Installation

Balljoint nut Torque Specs:

Upper: Torque to 50 ft lbs and then tighten nut to align cotter pin hole not exceeding 90ft lbs.
 Lower: Torque to 90 ft lbs and then tighten nut to align cotter pin hole not exceeding 130 ft lbs.

Note: These spindles are set up for 1973-1987 HD Rotor and Caliper. The HD Rotor is 1 1/4" wide.



Spindle Installation

Notes:

This spindle will not work with drum brakes.

A 7/16-14 bolt can be threaded into the spindle and used as an adjustable steering stop.

Instructions:

1. Remove the outer tie rods from the original spindles.
2. Trucks that are reusing existing 1973-1987 heavy half ton 1-1/4" thick rotors and calipers will need to remove the disc brake assemblies from the spindles. Trucks that are not reusing the existing brakes need to disconnect the brake hose from the brake line.
3. Remove the upper and lower ball joints from the spindle.
4. Remove the old spindles.

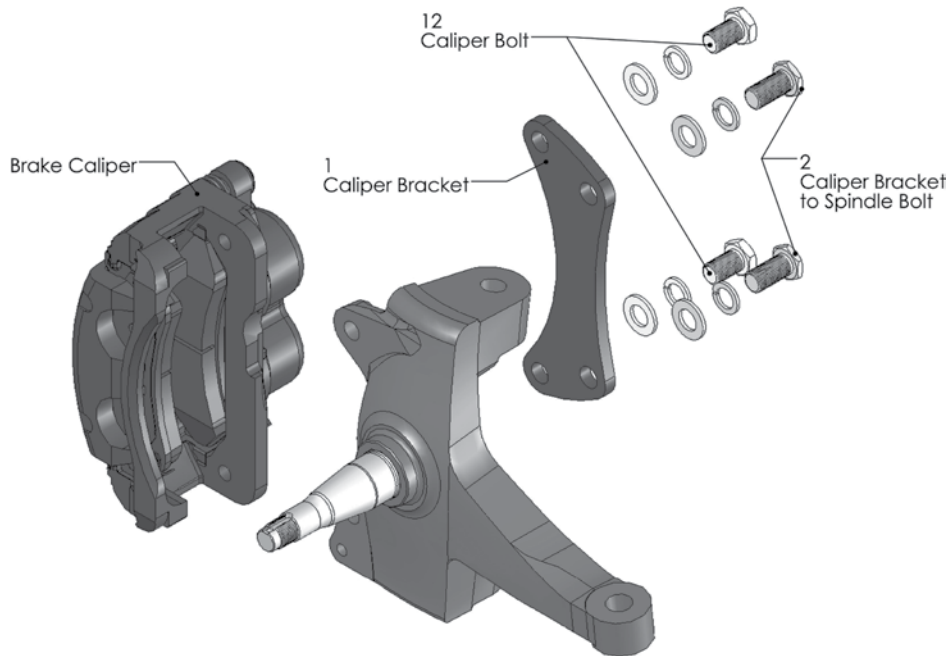

5. Install the new drop spindles onto the upper and lower ball joints.
6. Install the outer tie rods into the new spindles.
7. Install the caliper brackets. The supplied caliper brackets are designed to utilize 1973-87 heavy half ton 1-1/4" thick rotors and calipers. The brackets will mount to the inboard side of the spindle.
8. Pack the wheel bearings with grease. Install the inner bearings and the grease seal. Install the rotor/hub assembly. Install the outer wheel bearing, washer and spindle nut. Adjust the wheel bearings as follows:
 - a. Tighten the nut only slightly (no more than 12lb/ft.) spin the rotor in a forward direction to ensure the bearings are fully seated.
 - b. Check that the spindle nut is still tight. If not repeat step a.
 - c. Loosen the spindle nut until it is just loose.
 - d. Hand tighten the spindle nut and install the cotter pin. Do not use a wrench! If necessary loosen the nut to the first position the cotter pin can be installed into.
9. Install the caliper assemblies. The bleed screws will be towards the top.
10. If using new calipers connect the brake hose to the calipers and the frame. Bleed the brakes. Check for leaks.
11. Check that the rotor can turn freely and that the brakes do not drag.
12. Have the truck professionally aligned.