



Part # **11370110**_(HD)/**11370111**_(LD) - 1988-1998 C1500 4"/6" Drop Kit

Front Components

11379300/11379301	HD/LD Drop Spindles
11372310	Front CoilSpring Kit
22149847	Front HQ Series Shocks

Rear Components

11379511	Rear Flip Kit
11379611	C-Notch Kit
11379510	Rear HQ Series Shocks

Recommended Tools

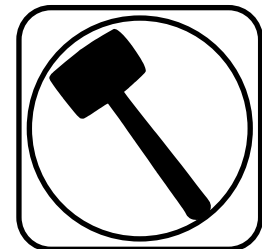
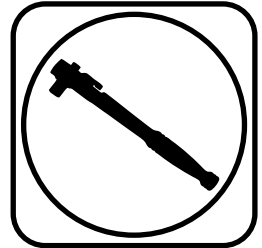

1988-1998 GM C1500 4"/6" Drop Kit

Installation Instructions

Table of contents

Page 2.....	Major Component List
Page 3.....	Drop Spindles
Page 4.....	Front CoilSprings
Page 5-6.....	Front Shocks
Page 7-11.....	C-Notch
Page 12-18.....	Rear Flip Kit
Page 18-20.....	HQ Series Shock Kit
Page 21.....	Finishing and Shock Adjustment

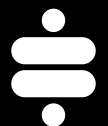



Major ComponentsIn the box

Part #	Description	QTY
56140880	Front CoilSprings	2
11379300/11379301	Light Duty/Heavy Duty Drop Spindles	1
90003079	Driver C-Notch	1
90003080	Passenger C-Notch	1
90003178	Brake Line Bracket	1
11379511	Flip Kit	1
70015643	Bump Stop	2
	Front & Rear Shocks	
986-10-042	4.75" Stroke Stud Top Shock - Front	2
986-10-020	7.55" Stroke Eyelet Top Shock - Rear	2
70011138	3/4" ID Shock Bushing (Installed in Rear Eye)	2
70011139	5/8" ID Shock Bushing (Installed in Body Front & Rear)	4
90002102	1/2" ID Shock Sleeve (Installed in Rear Eye)	2
90002068	Wide Trunnion (Installed in Front Shock Body)	2
90003083	Rear Upper Shock Brackets	2
90003085	Rear Lower Shock Bracket Spacers	2
70011140	Stud Top Bushing - Front	4
70011141	Stud Top Bushing Washer - Rear	4

Hardware Kit#99010081

The Drop Kit is supplied with a hardware kit. This hardware kit contains individual bags for the different kits within the main kit. The bags are labeled to help determine the correct hardware for the installation of the specific kits. The instructions will aid you in selecting the correct hardware for each component. The bags included in this kit are:

- C-Notch
- Brake Line Bracket
- Flip Kit
- Rear Lower Shock Mounting
- Rear Upper Shock Mounting

Front Suspension

The front components that will need to be installed are: Drop Spindles, Shocks, and CoilSprings. If you have never done this type of work before, we recommend getting a Factory Service Manual for proper procedures of disassembly and reassembly of the components for your truck.

Rear Suspension

The rear components that will be installed are rear C-Notches, Flip Kit, and rear HQ Series Shocks.



Part # 11379300_(HD)/**11379301**_(LD) - 1988-1998 C1500 Drop Spindles



Recommended Tools

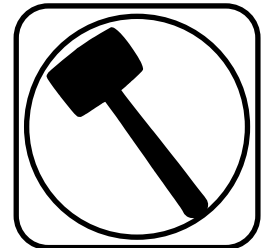
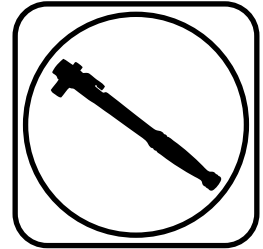

1988-1998 C1500 Drop Spindles

Installation Instructions

Installation

Torque Specs:

Splash Shield to Spindle:	19 ftlbs
Upper Balljoint:	74 ft lbs and then tighten nut to align cotter pin.
Lower Balljoint:	94 ft lbs and then tighten nut to align cotter pin.
Outer Tie Rod:	46 ftlbs and then tighten nut to align cotter pin.

THE 11379300 SPINDLES ARE DESIGNED FOR THE HEAVY DUTY BRAKES, 1 1/4" THICK ROTORS. THEY ARE USED IN KIT # 11370110

THE 11379301 SPINDLES ARE DESIGNED FOR THE LIGHT DUTY BRAKES, 1" THICK ROTORS. THEY ARE USED IN KIT # 11370111

NOTE

These spindles will increase your vehicle's track width by .200" per side.

15" wheels may require trimming of OEM lower control arms.



Part # 11372310 - 1988-1998 C1500 Front CoilSpring



Recommended Tools

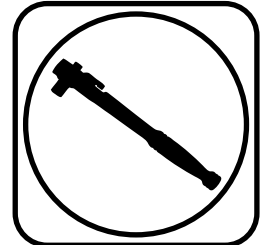

1988-1998 C1500 Front CoilSprings Installation Instructions

CoilSpring # 56140880 Installation

If installing Drop Spindles, attached the upper ball joint to the spindle in preparation of installing these CoilSprings.

The Front Suspension should be assembled with the Lower Ball joint disconnected from the Spindle.

1. Compress the CoilSpring with an Internal Spring Compressor.
2. Removed the bumpstop from the lower control arm.
3. With the OEM Spring Removed, insert the CoilSpring into the Pocket. SPECIAL ATTENTION NEEDS TO BE PLACED ON THE LOCATION OF THE ENDS OF THE SPRINGS TO MAKE SURE THEY ARE CLOCKED CORRECTLY . The end of the CoilSpring will nest into the receiver area of the Control Arm. If you line up the bottom, the top will be correct.
4. While holding the Spring in place, Slowly Jack the Lower Control Arm up until the Lower Ball joint can be Engaged into the Spindle. Install the Castle Nut and Torque to 65 ftlbs then tighten as needed to align cotter pin hole. Install Cotter Pin. Once the Ball joint is tight, remove the Spring Compressor.



Part # 22149847 - 4.75" Stroke HQ Series Shocks



Recommended Tools

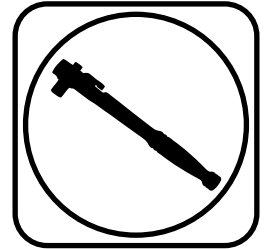

Stud/Trunnion HQ Series Installation Instructions

Table of contents

Page 6..... Components & Shock Installation

Due to manufacturing tolerances it may be necessary to clearance the Control Arm to get the Shock through the Control Arm opening.

Before installing the Shocks, the Spindles and CoilSprings need to be installed.

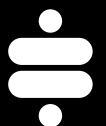



4.75" HQ Series Smooth Body Shocks

Major ComponentsIn the box

Part #	Description	QTY
986-10-042	4.75" Stroke Shock	2
70011139	5/8" ID Shock Bushing (Installed in Shock)	2
90002068	Wide Trunnion (Installed in Shock)	2
70011141	Bushing Support Washer	4
70011140	Stem Bushing	4
99372006	3/8"-24 Thin Jam Nut	4

4.

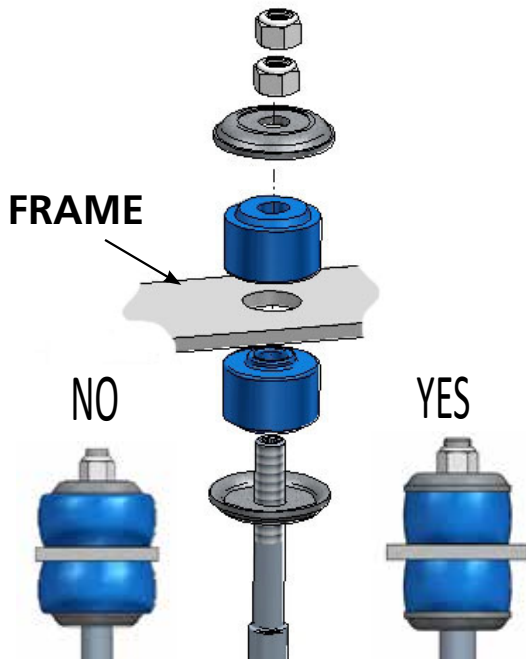

4. With the OEM shock removed, install the Ridetech shock. Remove the adjuster knob by loosening the set screw using the supplied Hex Key. Install a Bushing Support Washer on to the shock shaft followed by a Shock Stem Bushing. Insert the assembly through the factory shock hole in the frame. With the shock stud sticking through the frame, install a Shock Stem Bushing on to the shock stud followed with a Bushing Support Washer. Install a 3/8"-24 Thin Jam nut onto the threads and tighten to 35 inlbs. The Bushing should be tight, but not to the point that the bushing is bulging past the Support Washer. Install the 2nd 3/8-24 Thin Jam nut and tighten it against the first nut. Reinstall the Adjuster Knob, align the set screw with the FLAT side of the adjuster shaft that is sticking out of the top of the shock shaft.

5.

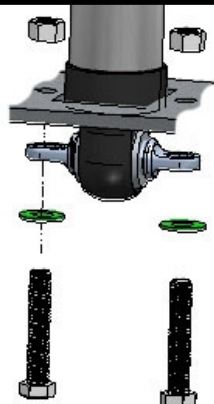

NOTE: It may be necessary to remove the OEM Speed Nuts from the Control Arm to allow room for the Shock to slide through the opening in the Control Arm. The Speed Nuts can be reinstalled after the Shock is in position.

5. Attach the Trunnion to the OEM Control arm using the OEM hardware. It may be necessary to rotate the Trunnion to get it in the correct position. This can be done by sticking a screwdriver in one of the slots and spinning the trunnion in the shock bushing.



Part # 11379611 - 1988-1998 C1500 C-Notch Kit

Recommended Tools

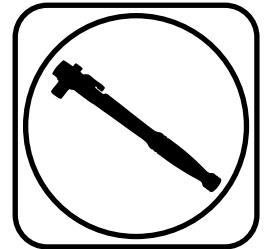

1988-1998 C1500 C-Notch Kit Installation Instructions

Table of contents

- Page 8..... Included Components
- Page 9-11..... C-Notch Installation

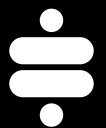



Major ComponentsIn the box

Item #	Part #	Description	QTY
1	90003079	Driver C-Notch	1
2	90003080	Passenger C-Notch	1
3	90003178	Brake Line Bracket	1
4	70014580	C-Notch Template - Driver	1
5	70014581	C-Notch Template - Passenger	1
6	70015643	Bump Stop	2

Hardware Bag

Part #	Description	Usage	QTY
99431008	7/16"-14 x 1 1/2" Bolt	C-Notch to Frame	26
99433002	7/16" SAE Flat Washer	C-Notch to Frame	52
99432001	7/16"-14 Nylok Nut	C-Notch to Frame	26
99311011	5/16"-18 x 1 1/4" Bolt	Brake Line Mount	3
99313001	5/16" SAE Flat Washer	Brake Line Mount	6
99312007	5/16"-18 Nylok Nut	Brake Line Mount	3
99371034	3/8"-16 x 1" Socket Head Bolt	Bump Stop	2
99373003	3/8" SAE Flat Washer	Bump Stop	2
99372002	3/8"-16 Nylok Nut	Bump Stop	2

Getting Started.....

These C-Notch can be installed with the bed on or removed. If installing them with the bed on the bed brace will have to cut different to allow for installation. IF you are installing the C-notch with the bed on, refer to Step 1. If you are removing the bed, refer to Step 10.

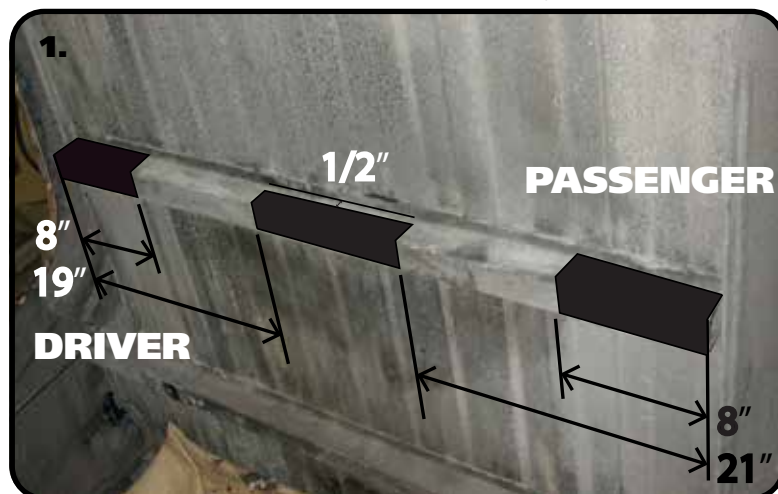

CUTTING THE BED BRACE WITH THE BED INSTALLED. IF REMOVING THE BED, REFER TO STEP 10.

1. Image 1 has the bed removed to clearly illustrate the cutting required of the bed brace. The first 8" of both side will need to be totally removed to slip the c-notch in. When cutting the center cut, leave 1/2" .



"C" Notch Installation

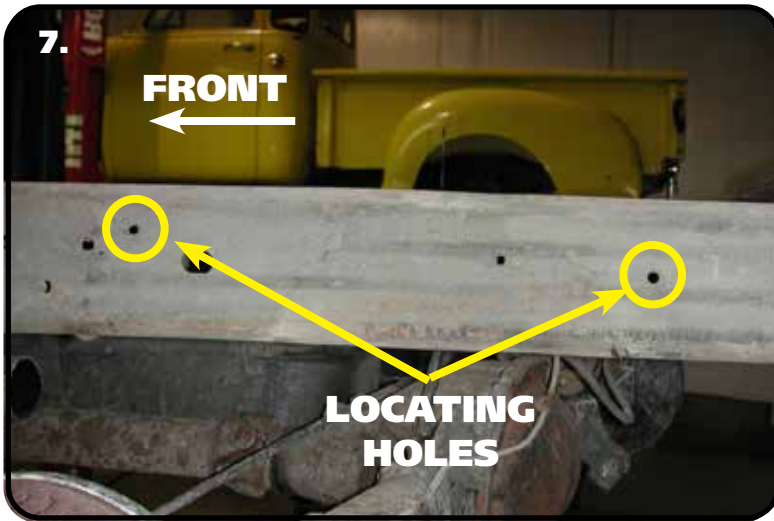

7. To allow maximum drop on this truck, the frame must be notched. The template for the notch will locate off of the 2 existing holes. **Image 7** illustrates the holes used. Use the supplied "C" Notch template to mark out the frame for cutting. Before cutting out the frame, support the frame in front of and behind the "C" Notch area. We suggest doing one side at a time.

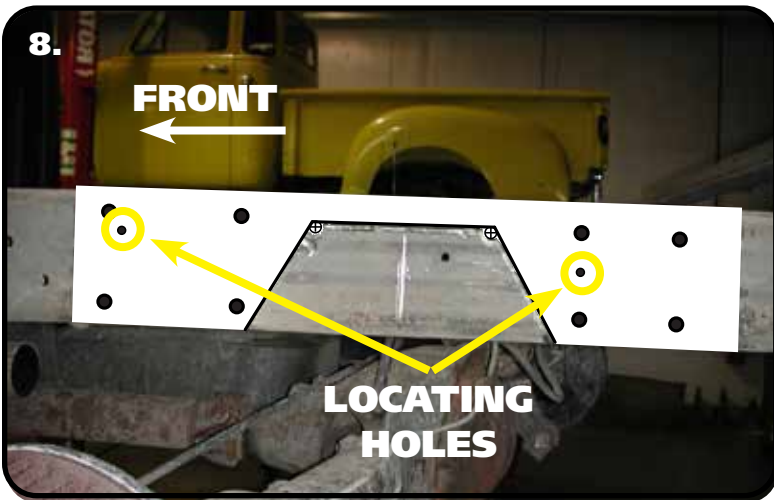

8. Use the supplied Template to mark the cut lines on the frame. Center Punch the "+" in the corners of the cut area.

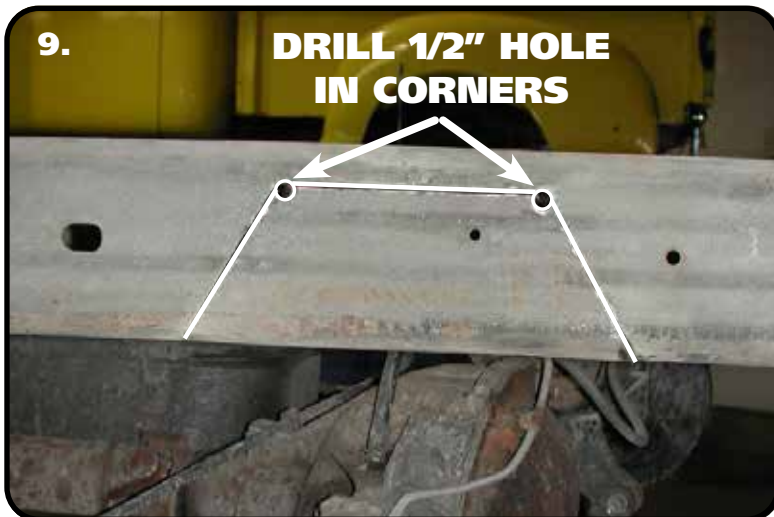

9. Drill out the two corners with a 1/2" drill bit. This will give the cut a round edge and eliminate the possibility for stress fractures. Then cut the notch with a saw-z-all, cutoff wheel, or plasma cutter. Grind all edges smooth. Check the inside of the frame for wires or lines before drilling or cutting.



"C" Notch Installation



5. Slip the C-Notch over the frame rail. Use the C-Notch as a template to drill the (10) holes in the side and (3) in the bottom. Use a 7/16" drill bit to drill the holes. Install a 1/2" Flat Washer on each of (10) 7/16"-14 x 1 1/2" Bolts. Insert a bolt/washer in each hole. Install a 7/16" Flat Washer and 7/16"-14 Nylok Nut on the threads of each bolt/washer and tighten. Torque the hardware to 75 ftlbs.



6. Install the Bump Stop using a 3/8"-16 x 1" socket head bolt, 3/8" flat washer, & 3/8"-16 nylok nut. Hold the Bump Stop with your hand and insert the bolt through the center of the bump stop. Line up the bolt of the bump stop with the hole in the c-notch. Install a 3/8" flat washer and 3/8" nut on the threads of the bolt. Tighten to 60 in-lbs.

REPEAT STEPS 1-5 for the 2nd C-Notch.

STEPS 7-9 ARE DRIVER SIDE ONLY!



7. Drill out the small rear locating hole to 5/16". Also, remove the nut from the 7/16" Bolt above the small hole. Install a 5/16" Flat Washer on (1) 5/16"-18 x 1 1/4" bolt and insert into the drilled hole.



"C" Notch Installation



13. Slip the Brake Line Bracket over the 7/16" and 5/16" Bolts sticking through the back side of the frame. Install a Flat Washer & Nut on each and tighten.



14. Install a 5/16" Flat Washer on each of (2) 5/16" x 1 1/4" Bolts. Install them in the Brake Line Bracket and slip the OEM brake line bracket over the (2) bolts. Install a 5/16" Flat washer & 5/16" Nylok Nut on each bolt and tighten.

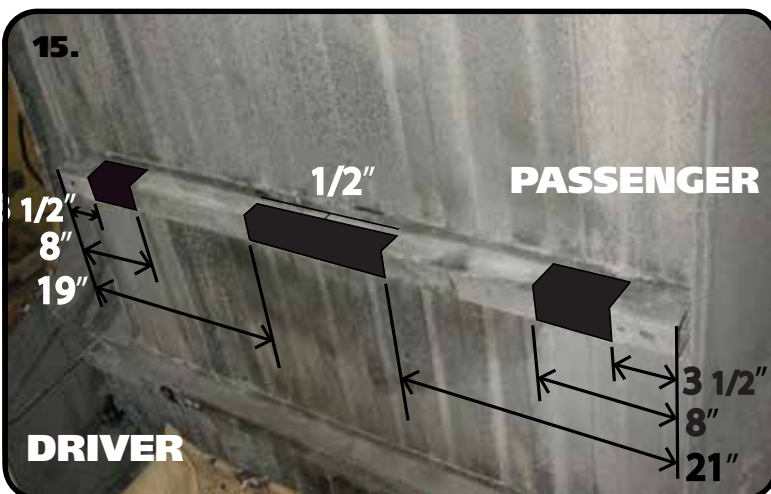

15. The bed brace between the wheel wells will need to be trimmed to clear the C-Notches and center section of the axle housing. Use **Image 15** as a reference for cutting. The outer cuts require removing the entire section of the brace. Leave a 1/2" of the brace in the center cut. Reinstall the bed using the OEM hardware.



Part # 11379511 - 1988-1998 C1500 Axle Flip Kit

Recommended Tools

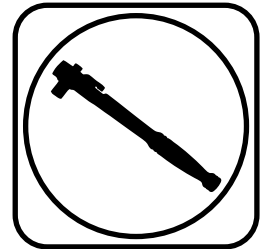

1988-1998 C1500 Axle Flip Kit Installation Instructions

Table of contents

Page 13.....	Included Components & Getting Started
Page 14.....	Disassembly
Page 15.....	Part Orientation
Page 16-17.....	Flip Bracket Installation

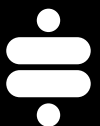



Major ComponentsIn the box

Item #	Part #	Description	QTY
1	90003082	Axle Flip Bracket with offset hole	2
2	90003084	Leaf Spring Plate	2
3	99566005	9/16"-18 x 7 1/2" U-bolt	4
4	90001329	Carrier Bearing Spacer	1

Hardware Bag - Flip Kit

Part #	Description	Usage	QTY
99566003	9/16" Flat Washer	U-bolts	8
99562010	9/16"-18 High Nuts	U-bolts	8
99375004	3/8"-16 x 2 1/2" Hex Bolt	Carrier Bearing Spacer	2
99372002	3/8"-16 Nylok Nut	Carrier Bearing Spacer	2
99373003	3/8" SAE Flat Washer	Carrier Bearing Spacer	4

Getting Started.....

16. Raise the vehicle to a safe and comfortable working height and support it by the frame. You will need to be able to move the rear differential up and down. Use a jack under the rear axle so it can be raised and lowered as needed during the install.
 17. Jack up the rear end slightly to remove the tension from the rear shocks. Remove the shock absorbers. For proper function, they should be replaced with the Ridetech HQ Series shock kit, 11379510.
 18. Let the tension of the rear springs, but keep the jack touching the rear axle.
 19. Remove the u-bolts and axle clamps to disengage the axle from the leaf springs.
 20. Lower the axle to get clearance on the leaf springs, but DO NOT strain the brake line.
 21. The easiest way to install the flip brackets is to drop the leaf springs. The leaf spring packs are heavy, we recommend a helper to remove them.
 22. Support the front of the leaf spring and remove the front leaf spring bolt and swing the leaf spring down to touch the axle.
 23. Support the rear of the leaf spring and remove the frame shackle bolt. With assistance, remove the leaf spring pack and set it to the side for the moment.
- Repeat Steps 6 - 8 on the 2nd leaf spring.
24. Jack up the axle enough to be able to reinstall the leaf springs under the axle.
 25. Reinstall the leaf spring packs, but DO NOT tighten the attaching hardware at this time.



Disassembly



26. The leaf spring locating pin needs to be flipped over. Currently, the nut for the pin is on the top side of the leaf spring pack. The nut will need to be on the bottom side for proper location of the flip bracket. The u-bolt locating plate will need to be removed and discarded. To remove the pin and u-bolt locator, clamp the leaf springs together in front of and behind the u-bolt locator. With the leaf spring clamped, remove the nut from the locating pin. Next, remove the u-bolt locator and discard it.



27. Remove the locating pin from the leaf spring pack.



28. Reinstall the locating pin from the TOP side. Reinstall the nut on the BOTTOM side and tighten. With the nut tight, remove the clamps. Repeat on the second spring.



Part Orientation

29.

FRONT

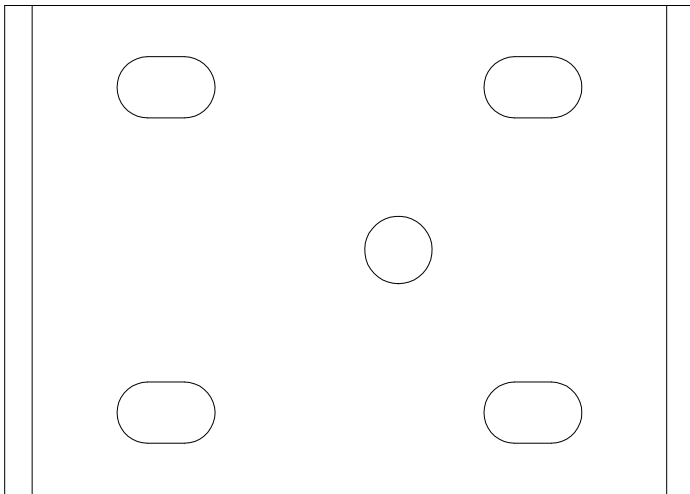
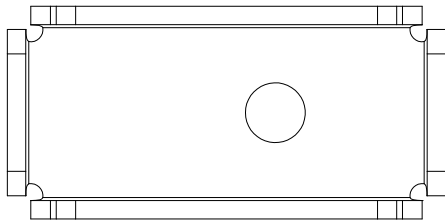

29. The Flip Kit has an offset locating holes to center the wheel in the wheel opening. **Image 29** illustrates a top view of the Flip Bracket and the Leaf Spring Plate. Notice the CENTER Hole is offset to the FRONT of the truck. This kit will move the axle rearward.

30.

FRONT

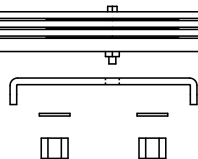
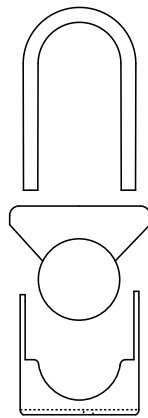

30. **Image 30** illustrates the included parts exploded to assist you in the location and orientation of the parts included.



Flip Bracket Installation

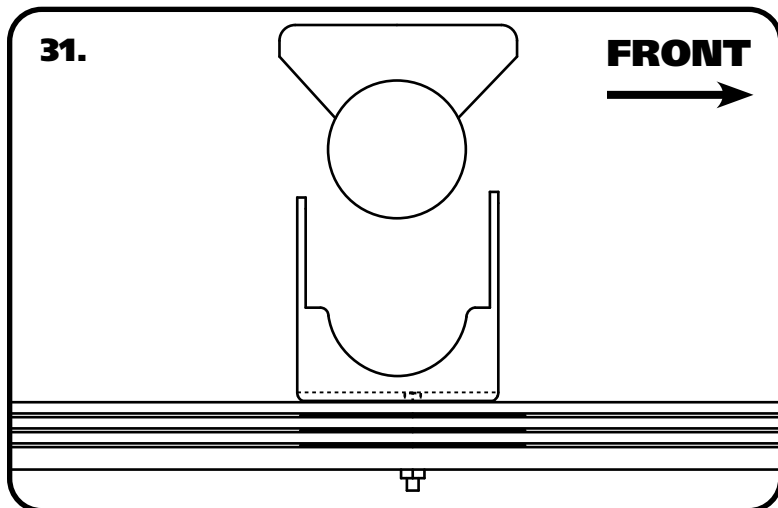

31. Set the Flip Bracket onto the leaf spring with the CENTER HOLE OFFSET TO THE FRONT OF THE TRUCK.

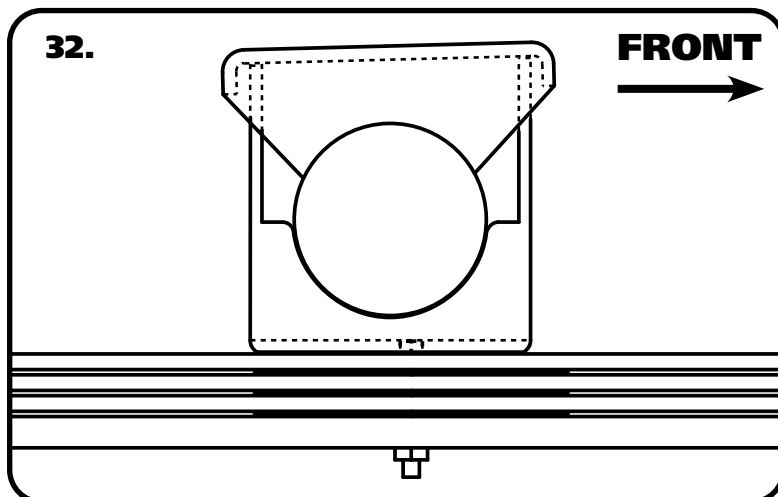

32. Slowly lower the axle into the Flip Bracket making sure the tabs go up into the leaf spring saddle.

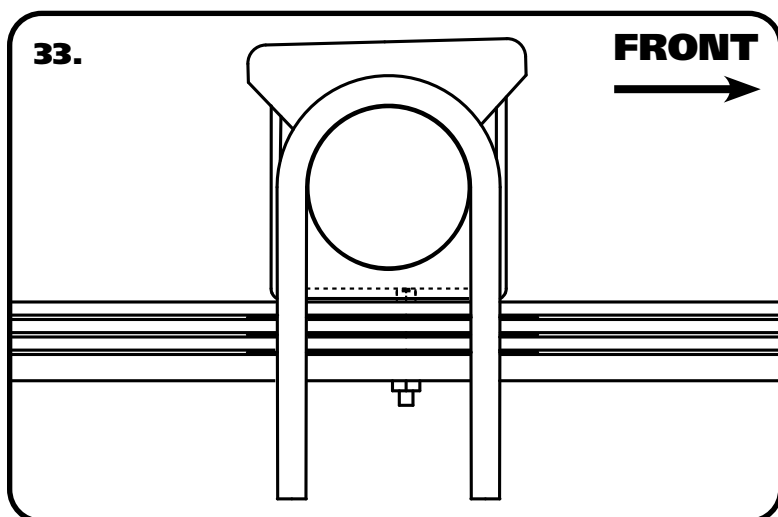

33. Slip the U-Bolts over the axle tube with the threads pointing down.



Flip Bracket Installation

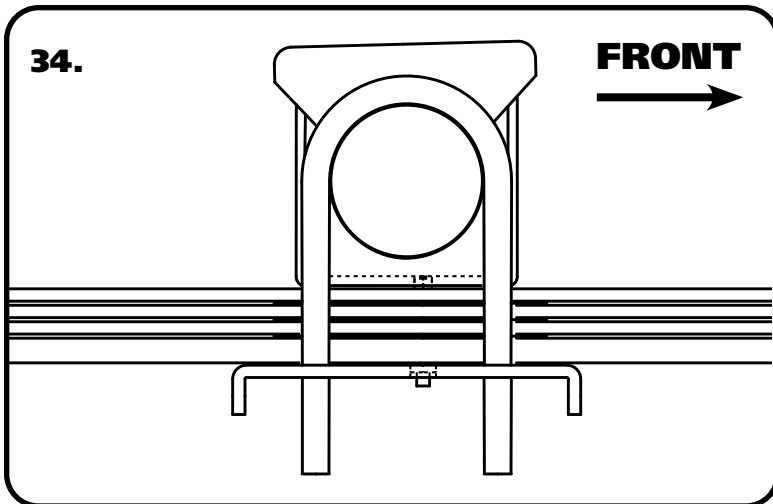

34. Slip the Leaf Spring Bracket up onto the U-Bolts WITH THE OFFSET HOLE FORWARD.

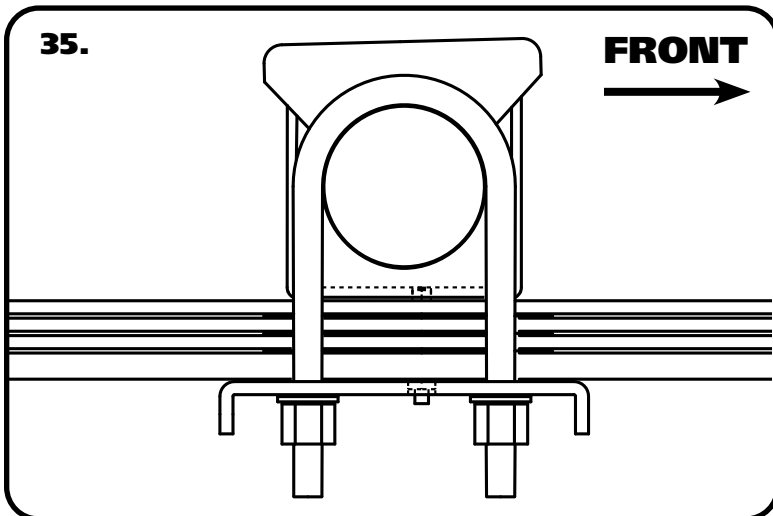

35. Hold the Leaf Spring Bracket in place and install (4) 9/16" Flat Washer & (4) 9/16" Hugh Nuts on the threads of the u-bolts. Snug the nuts down evenly and tighten them in a crisscross fashion to 90 ftlbs.



**TRUCKS WITH CARRIER BEARINGS ONLY!
IF YOUR TRUCK DOESN'T HAVE A CARRIER BEARING, SKIP TO STEP 39.**

36. The driveshaft carrier bearing will need to be relocated to optimize driveline angles at your new lower ride height. Unbolt the carrier bearing.



Carrier Bearing Spacer equipped trucks



37. Install carrier bearing spacer between carrier bearing housing and cross member. Secure with 3/8" x 2 1/2" bolts, 3/8" flat washers, & 3/8" nylok nuts. Torque to 30 ftlbs.

Part # 11379510 - 88-98 C1500 Rear Shock Kit for Flip Kit



Recommended Tools

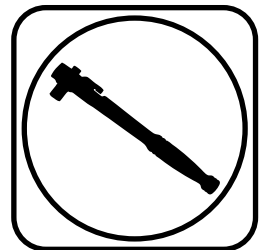

HQ Series Shock Kit

Installation Instructions

Table of contents

Page 19..... Components

Page 20..... Getting Started and Lower Mount Installation



7.55" HQ Series Smooth Body Shocks

Major ComponentsIn the box

Part #	Description	QTY
986-10-020	7.55" Stroke Shock	2
70011138	3/4" ID Shock Bushing (Installed in Shock Eyelet)	2
90002102	1/2" ID Shock Sleeve (Installed in Shock Eyelet)	2
70011139	5/8" ID Shock Bushing (Installed in Shock Body)	2
90002068	Wide Trunnion (Installed in Shock Body)	2
90003083	Lower Shock Relocation Bracket	2
90003085	Lower Shock Relocation Bracket Spacer - 1" OD x 9/16" ID x 1.660 Long	2

HARDWARE

Part #	Description	Usage	QTY
99561010	9/16"-18 x 3 1/2" Hex Bolt	Lower Shock Bracket to OEM Mount	2
99563002	9/16" SAE Flat Washer	Lower Shock Bracket to OEM Mount	4
99562006	9/16"-18 Nylok Nut	Lower Shock Bracket to OEM Mount	2
99371005	3/8"-16 x 1 1/4" Hex Bolt	Lower Shock Bracket to OEM Mount	2
99373002	3/8" Flat Washer	Lower Shock Bracket to OEM Mount	4
99372001	3/8"-16 Nylok Nut	Lower Shock Bracket to OEM Mount	2
99501064	1/2"-13 x 2 3/4" Hex Bolt	Shock to Lower Shock Mount	2
99503014	1/2" Flat Washer	Shock to Lower Shock Mount	4
99502009	1/2"-13 Nylok Nut	Shock to Lower Shock Mount	2
99311011	5/16"-18 x 1 1/4" Hex Bolt	Upper Shock Mounting	4
99313001	5/16" SAE Flat Washer	Upper Shock Mounting	8
99312007	5/16"-18 Nylok Nut	Upper Shock Mounting	4

The Rear Shocks will be installed after the Flip Kit is installed.

38. If you haven't already, remove the rear shocks from the truck.



Getting Started.....

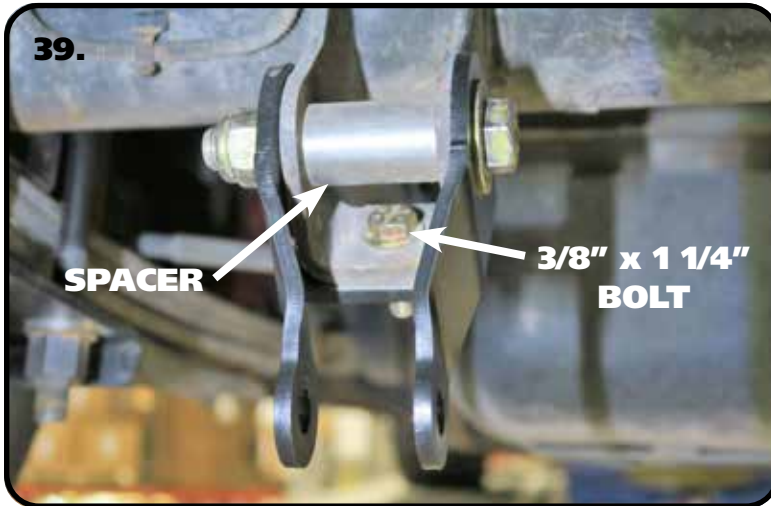

39. This kit includes new Lower Shock Mounts to correct the angle of the shocks. They attach to the OEM shock mounts. Slip the Lower Mount over the OEM shock mount lining up the 2 side holes with the OEM shock hole. Use the bracket as a template to drill a 3/8" hole in the OEM mount. Install a 3/8" Flat Washer on a 3/8"-16 x 1 1/4" Bolt and insert in through the small hole with the bolt head on the INSIDE of the OEM shock mount. Install a 3/8" Flat Washer followed by a 3/8"-16 Nylok Nut on the threads of the bolt sticking through the bracket. Do not tighten at this time. Insert the Spacer (1.660" Long) into the OEM shock mount in place of the OEM shock aligning the center hole with the OEM shock holes. Install a 9/16" Flat Washer on a 9/16"-18 x 3 1/2" Bolt, insert the bolt/washer through the Lower Mount, OEM Mount, and Spacer. Install a 9/16" Washer and 9/16"-18 Nylok Nut on the threads sticking through the mounts/spacer. Tighten the 3/8" Hardware to 55 ftlbs. Tighten the 9/16" Hardware to 100 ftlbs. Repeat for the other shock bracket.



40. Install a 5/16" Flat Washer on each of (2) 5/16"-18 x 1 1/4" Bolts. Install the bolts/washers in from the top with the threads pointing down. Line up the bolt holes in the Shock Trunnion with the bolts sticking through the frame and insert the shock in place. While holding the shock in place, install a 5/16" Flat Washer and 5/16"-18 Nylok Nut on the threads sticking through the trunnion. Torque the hardware to 25 ftlbs. Repeat for the other shock.



41. Install a 1/2" flat Washer on a 1/2"-13 x 2 3/4" Bolt. Line the center of the inner sleeve of the shock with the mounting holes in the lower shock bracket. Insert the bolt/washer through the lined up holes. Install a 1/2" Flat Washer and 1/2"-13 Nylok Nut on the threads sticking through. Torque to 50 ftlbs.



Finishing.....

42. Reinstall the bed if you removed it.
43. Set the truck on the ground. Torque the leaf spring and shackle hardware to 80 ftlbs.

Shock Adjustment

Shock adjustment 101- Single Adjustable

Rebound Adjustment:

How to adjust your new shocks

The rebound adjustment knob is located on the top of the shock absorber protruding from the eyelet or stud top. You must first begin at the ZERO setting, then set the shock to a street setting of 12 or handling setting of 8.

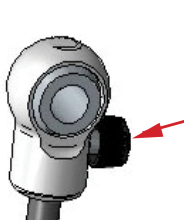

-Begin with the shocks adjusted to the ZERO rebound position (full stiff). Do this by rotating the rebound adjuster knob clockwise until it stops.

-Now turn the rebound adjuster knob counter clockwise 12 clicks. This sets the shock at 12 for a street setting. If you are after a handling setting only go 8 clicks.

Take the vehicle for a test drive.

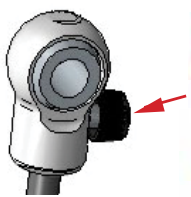

-if you are satisfied with the ride quality, do not do anything, you are set!

-if the vehicle is too soft increase the damping effect by rotating the rebound knob clockwise 3 additional clicks.

-If the vehicle is too stiff rotate the rebound adjustment knob counter clock wise 2 clicks and you are set!

Take the vehicle for another test drive and repeat the above steps until the ride quality is satisfactory.

Note:

One end of the vehicle will likely reach the desired setting before the other end. If this happens stop adjusting the satisfied end and keep adjusting the unsatisfied end until the overall ride quality is satisfactory.