



Part # 11370201 - 88-98 GM C1500 CoilOver System

Front Components:

11372899	Front Lower StrongArms
11373699	Front Upper StrongArms
11379300	Front Spindles
11373510	Front Coilovers
11379100	Front MuscleBar

Rear Components:

11377199	Rear Wishbone System
11376510	Rear Coilover Instructions

Miscellaneous Components:

85000000	Spanner Wrench
----------	----------------

Recommended Tools

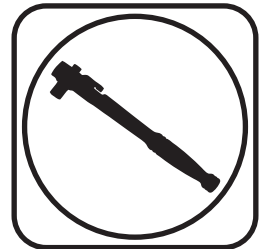

88-98 GM C1500 Coilover System Installation Instructions

Table of contents

Pages 2-6.....	Front Coilovers
Pages 7-10.....	Lower StrongArms
Pages 11-15.....	Upper StrongArms
Pages 16.....	Spindles
Pages 17-20.....	Front MuscleBar
Pages 21-38.....	Rear 4Link
Pages 40-42.....	Rear CoilOver
Pages 43-47.....	Preloading, Ride Height, and Shock Tuning

THE SPINDLES SUPPLIED IN THIS KIT ARE DESIGNED FOR THE HEAVY DUTY BRAKES, 1 1/4" ROTORS.





Part # 11373510 - 88-98 C1500 Front HQ Series CoilOvers

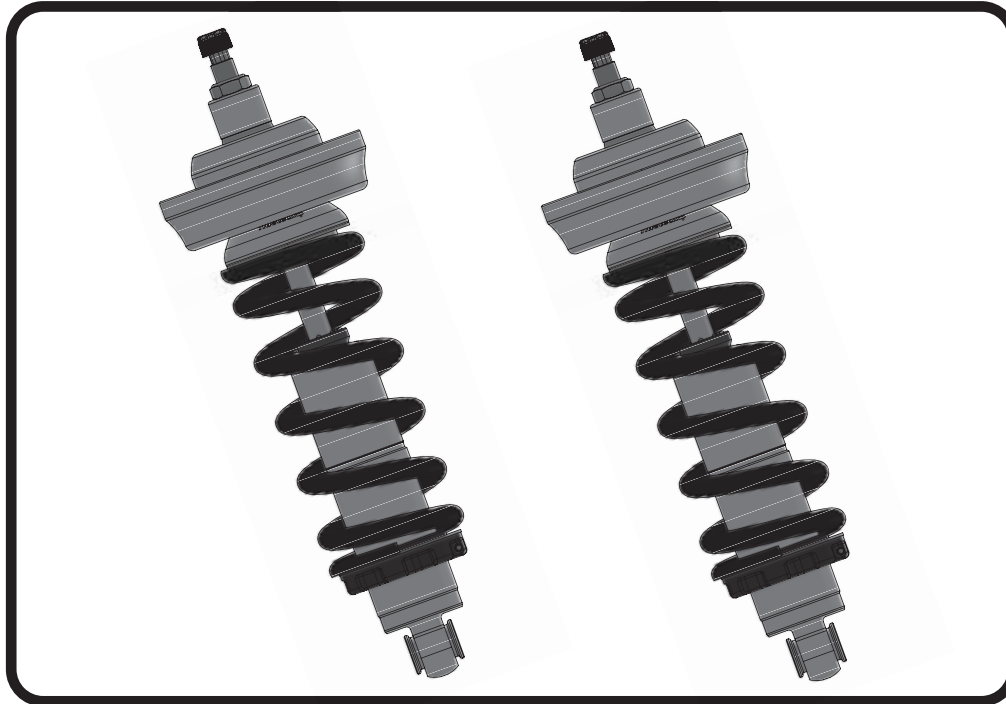

Recommended Tools

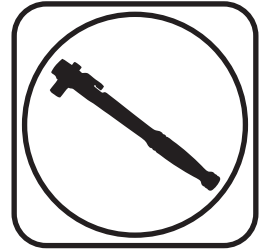

1988-1998 C1500 HQ Series Front CoilOvers Installation Instructions

Table of contents
Page 3..... Included Components
Page 4-7..... CoilOver Installation

THIS COILOVER KIT IS DESIGNED TO BE USED WITH RIDETECH STRONGARMS. THIS KIT WILL **NOT** WORK WITH OEM CONTROL ARMS.





Major ComponentsIn the box

Item #	Part #	Description	QTY
1	982-10-803	3.6" Stroke HQ Series Shock	2
2	90009989	2.75" Shock Stud (Installed on Shock) - Includes Adjuster Knob & Screw	2
3	59080850	Coilspring 8" 850lb	2
4	70010828	Delrin Spring Washer	4
5	803-00-199(kit)	Lower Spring Adjuster Nut (803-00-199 kit)	2
6	803-00-199(kit)	Adjuster Nut Locking Screw (803-00-199 kit)	2
7	90002070	Dropped Upper Spring Mount	2
8	803-00-199(kit)	CoilSpring Plate Retaining Ring (803-00-199 kit)	2
9	900001337	Upper Shock Mount	2
10	90002312	2" Stud Top Spacer	2
11	90001287	.5" Upper Delrin Ball Cap	2
12	90001903	Lower Delrin Ball for Shock Stud Top	2
13	90001904	Upper Delrin Ball for Stock Stud Top	2
14	99562003	9/16"-18 Nylok Nut	2
15	210-35-120-0	Adjuster Knob	2
16	90009969	4-40 x 1/4" Pan head Torx Screw	2
	70012161	2.75" Metering Rod - Installed in Stud Top	2
	90001994	5/8" ID Bearing (installed in shock body & eyelet)	2
	90001995	Bearing Snap Ring (installed in shock & eyelet body)	4

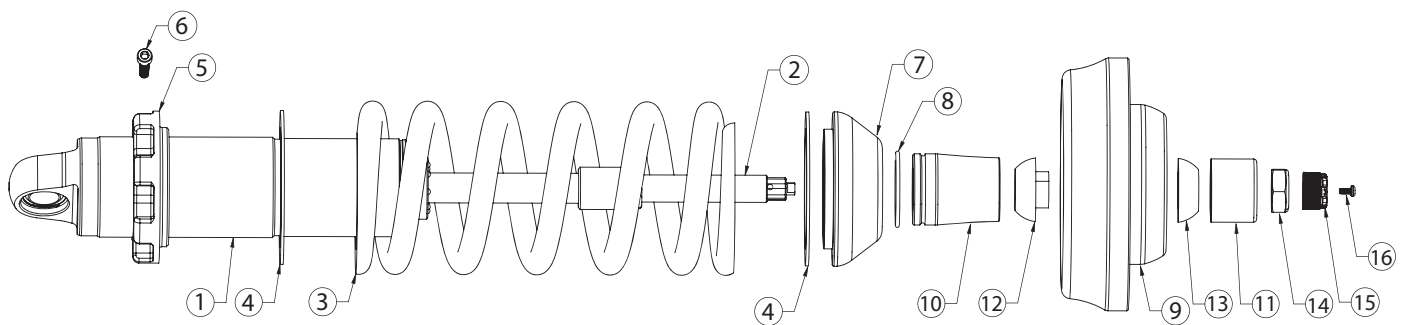



CoilOver Installation

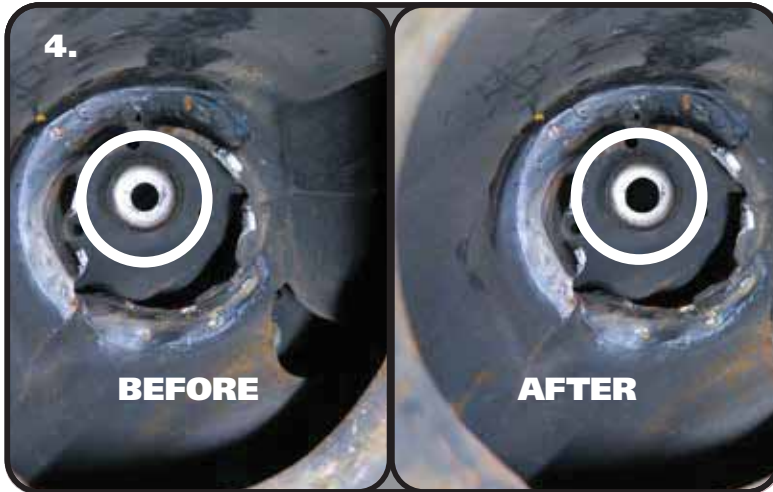

1. Raise and support truck at a safe, comfortable working height. Let the front suspension hang freely.

2. Remove the coil spring, shock absorber, bump stop, upper control arm, and lower control arm. Refer to factory service manual for proper disassembly procedure.

3. Install the CoilOver StrongArms. Refer to the StrongArm instructions.

4. Drill the OEM shock hole out to 3/4". A Unibit stepped drill bit works well for this.

5. The CoilOvers will need to be partially disassembled to install them into the truck. To disassemble the CoilOver you need to:

a. Remove Screw (1) from center of Adjustment Knob (2) using a T10 Torx to remove Adjustment Knob.

b. Remove Nylok Nut(3), Delrin Upper Cap(4), Delrin Upper Ball(5) and Billet Upper Mount(6).

c. The Delrin Lower Ball(7) will most likely be stuck in the shock hole of the billet upper mount. Remove it for the time being.

Repeat on second CoilOver.

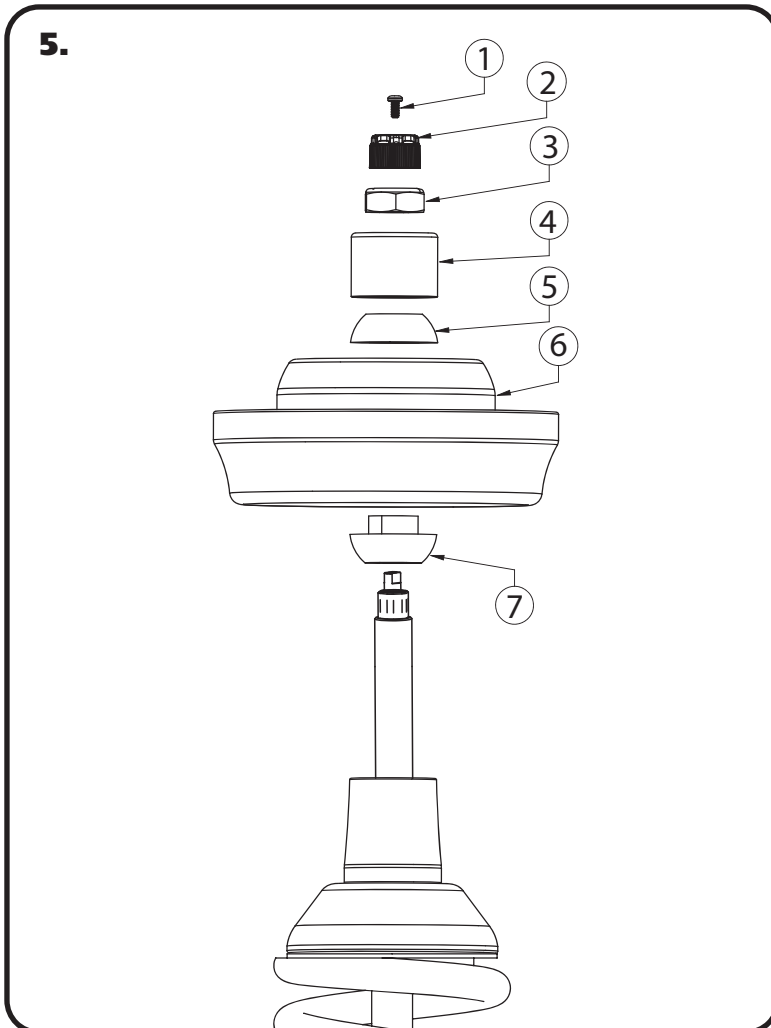



CoilOver Installation

6.



6. The Aluminum Upper CoilOver Support has the center mounting hole offset as is the shock mounting hole in the frame. They will need to be test fitted in each side to check for alignment of the OEM shock hole and the shock hole in the aluminum upper mount. It may be necessary to trim the coil spring retaining fingers to get proper alignment.

7.



7. They will need to be test fitted in each side to check for alignment of the OEM shock hole and the shock hole in the aluminum upper mount. Due to variances throughout the years of these trucks being produced, it may be necessary to trim the coil spring retaining fingers to get proper alignment. Stick the mount up in the frame pocket with the large opening down. Rotate the upper mount to get the shock holes aligned. Determine the orientation that achieves the best alignment. If the holes DO NOT perfectly align, trim the necessary coil spring fingers to get the mount in the correct position with the holes aligned.

8.



8. We used a die-grinder with a cut off wheel to trim the fingers. On some trucks, the holes will line up without trimming



CoilOver Installation

9.

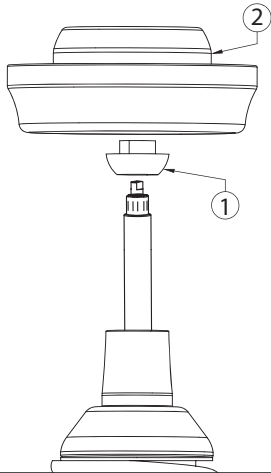

9. After hole alignment has been achieved, reinstall the Bottom Delrin Ball and Aluminum Upper Mount.

10.



10. Insert the CoilOver with the Aluminum Upper installed into the OEM coil spring pocket. You may need to rotate the upper mount while inserting the assembly to get the best alignment of the shock holes.

11.

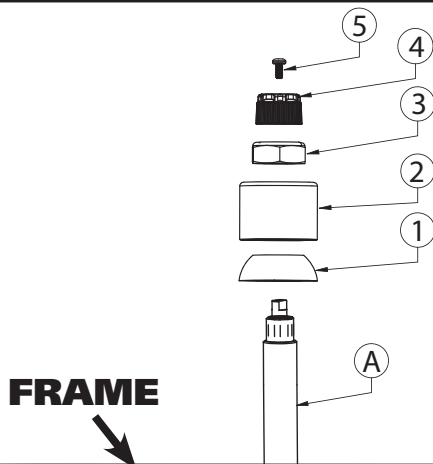

11. Hold the CoilOver in place. Install the Upper Delrin Ball (1), Aluminum Upper Cap (2), 9/16"-18 Nylok Nut (3), Adjuster Knob (4), & Adjuster Knob Retaining Screw (5) on the Stud Top (A) that is sticking through the frame. See below for nut tightening.

TIGHTENING THE TOP 9/16"-18 NUT: SNUG THE NUT DOWN AGAINST THE TOP CAP. YOU NEED TO BE ABLE TO ARTICULATE THE SHOCK BY HAND. WE TORQUE THE NUT TO 80 INLBS USING A 7/8" CROWS FOOT WRENCH ON A TORQUE WRENCH.



Part # 11372899 - 1988-1998 GM C1500 Front Lower StrongArms



Recommended Tools

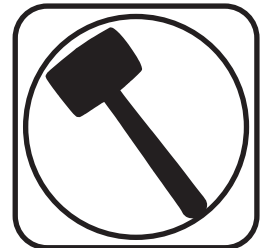

1988-1998 GM C1500 Lower StrongArms Installation Instructions

Table of contents

- Page 8..... Lower Control Arm Components
- Page 9..... Getting Started & Installation
- Page 10..... Installing Spindles



Lower Control Arm ComponentsIn the box

Item #	Part Number	Description	QTY
1	90001335	Driver Lower Control Arm (Shown)	1
1	90001336	Passenger Lower Control Arm	1
2	90000897	Lower Ball joint Assembly - Proforged # 101-10054	2
3	90000198	Rear Inner Sleeve - 3.0" Long	2
4	70010759	Delrin Bushing - with 2" Diameter Ledge	8
5	90000199	Front Inner Sleeve - 3.5" Long	2
PARTS NOT SHOWN IN DIAGRAM			
	90002043	CoilOver Bearing Spacers	4
	99501050	1/2"-13 x 2 1/2" Hex Bolt	2
	99502009	1/2"-13 Nylok Nut	2
	99503014	1/2" SAE Flat Washer	4

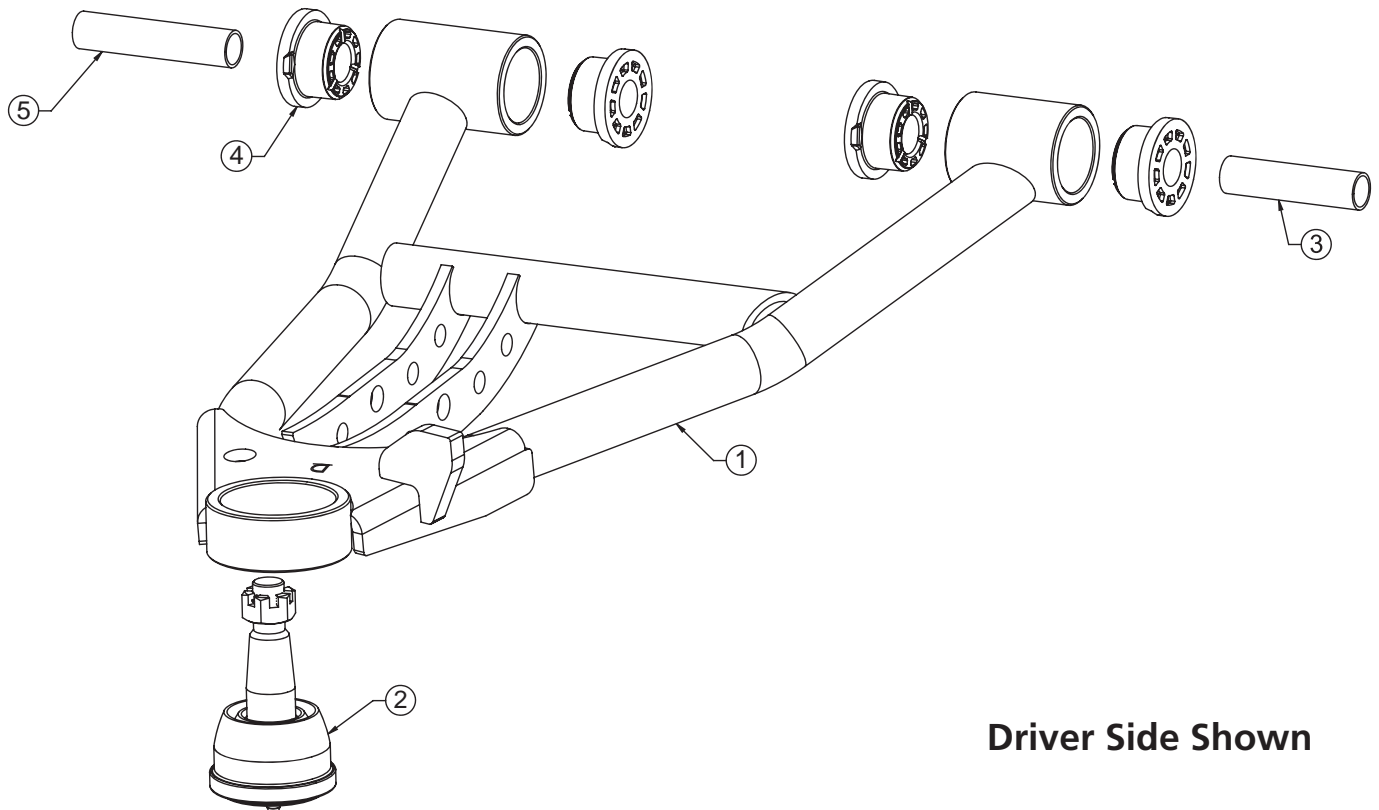



Getting Started.....

Congratulations on your purchase of the Ridetech C1500 StrongArms. These StrongArms have been designed to give your C1500 excellent handling along with a lifetime of enjoyment. Some of the key features of these StrongArms: Balljoint angles have been optimized for the lowered ride height, Delrin bushings are used to eliminate bushing deflection along with providing free suspension movement through the entire travel. The Delrin bushings are made from a material that is self lubricating so no grease zerks are needed.

Note: These control arms are designed for use with the Ridetech CoilOvers and the MuscleBar swaybar. **The factory shocks and springs will not fit these arms.**

Installation

1. Remove the lower control arms from the truck. If you are replacing the upper control arms and spindle, remove them too. Refer to a Factory Service Manual for the proper method.

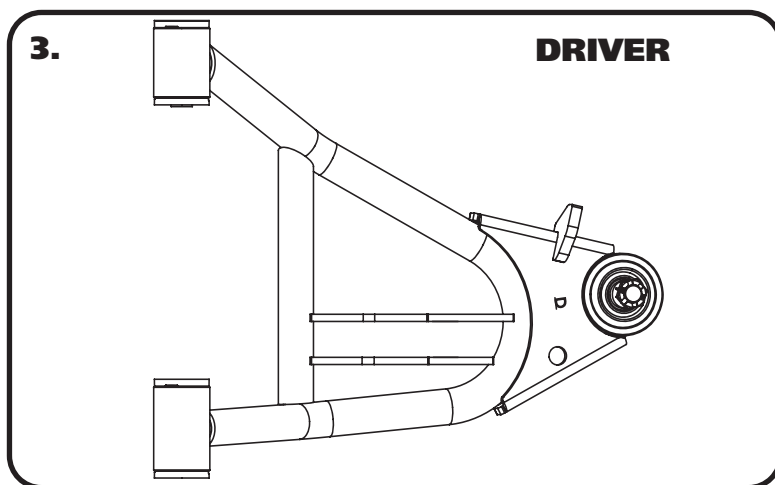

3. After removing the factory lower control arm, clean the bushing mounting surfaces on the frame. The Control Arms are marked "D" for Driver and "P" for Passenger. The Ball joint Pin points up and the steering stop is positioned to the rear of the truck. Fasten the lower arm to the frame with the OEM hardware. Torque to 120 ft-lbs.

Note: On some trucks the frame brackets may be pinched and will need to be spread back apart to allow the bushing to slide in.

Install the CoilOvers at this time. Refer to the CoilOvers instructions for Assembly.

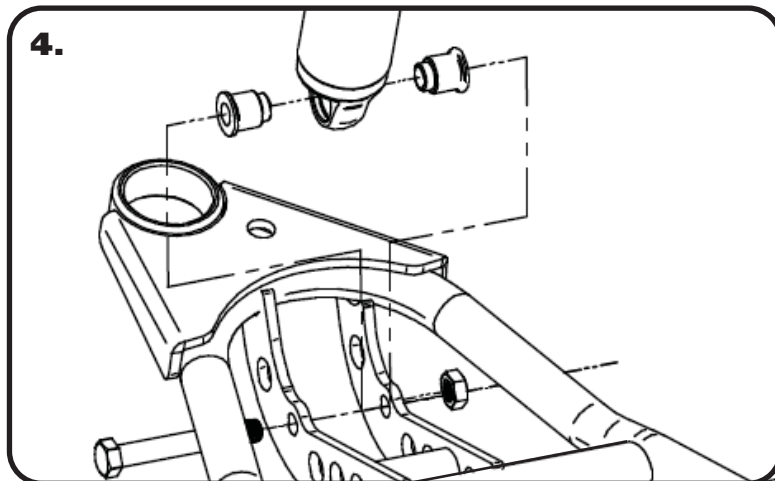

4. Insert the Bearing Spacers into the lower shock bearing. The SMALL end goes into the bearing. Swing the Control Arm up, line up the 1/2" holes with the bearing spacers. Install a 1/2" flat washers on a 1/2"-13 x 2 1/2" hex bolt, insert it through the hole. Install a 1/2" flat washer and nylok nut. Torque the hardware to 75 ftlbs.



Installing Spindle



5. Attach the Spindle to the control arms.

Torque Specs:

Lower Balljoint - 94 ftlbs and tighten to line up cotter pin.

Install the Cotter Pin after tightening the ball joint nut.

6. Tighten all fasteners. If you are going to install the Ridetech MuscleBar, now is a good time to do it.

Suggested Alignment Specs:

Camber:	Street: -.5 degrees
Caster:	Street: +3.0 to + 5.0 degrees
Toe:	Street: 1/16" to 1/8" toe in



Part # 11373699 - 88-98 GM C1500 Front Upper StrongArms



Recommended Tools

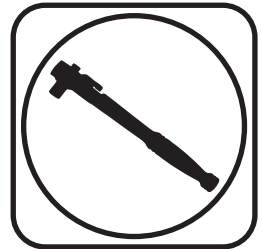

1988-1998 GM C1500 Upper StrongArms Installation Instructions

Table of contents

Page 12..... Included Components & Getting Started
Page 13-15..... StrongArm Installation





Lower Control Arm ComponentsIn the box

Item #	Part Number	Description	QTY
1	90001333	Driver Upper Control Arm	1
1	90001334	Passenger Upper Control Arm	1
2	90000900	Upper Ball Joint - Proforged # 101-10053	2
3	70010759	Delrin Control Arm Bushing	8
4	90001097	Delrin Bushing Inner Sleeve	4
	99251020	1/4"-20 X 1/2" Thread Forming Screw - Not Shown	4

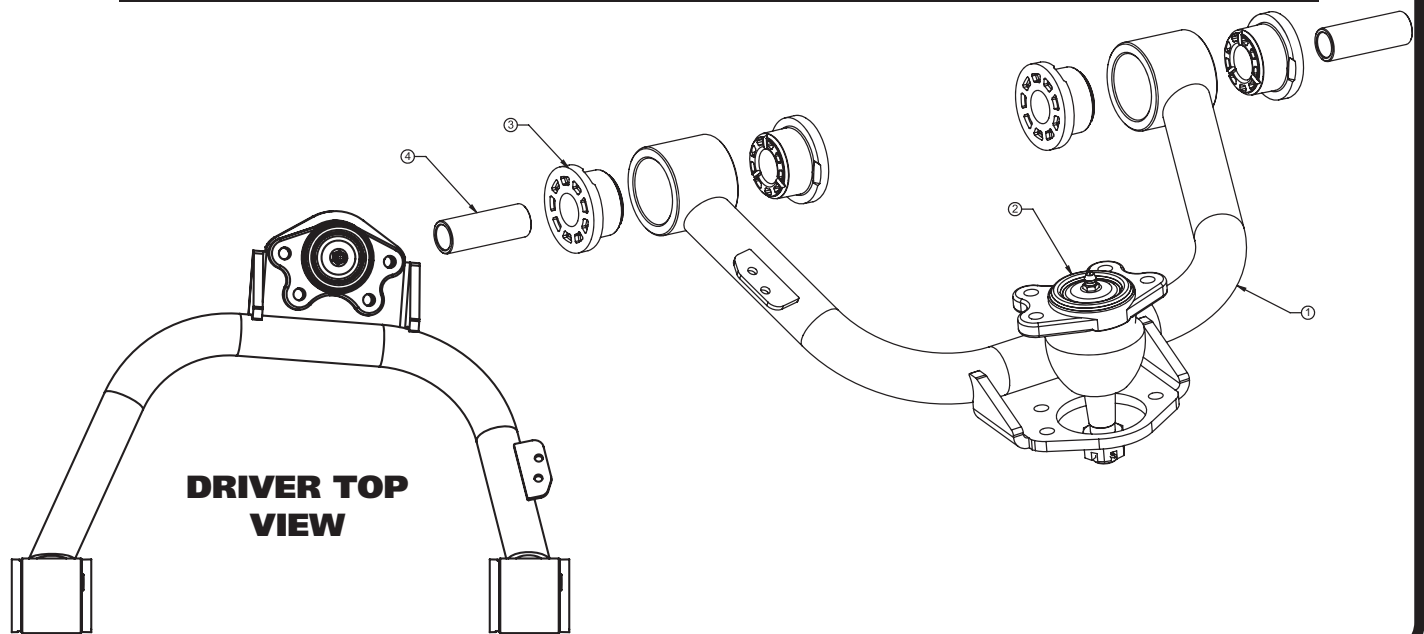

Getting Started.....



1. The OEM upper control arms will need to be removed from the truck. Start by disconnecting the brake line from the upper control arm. Disconnect the ABS cable from the control arm. You will need to remove one of the ball joint bolts to disconnect it.



StrongArm Installation



2. Remove the Upper Control Arms. The Camber Bolts need to be reinstalled in the same positions they are removed from. We recommend marking their positions for reassembly. Refer to the factory service manual for disassembly procedure. After removing the factory upper control arm, clean the bushing mounting surfaces on the frame.



3. If your truck has never needed the caster or camber changed, it may still have the locating slugs in the upper control arm mounts. **See Image 3.** Skip to Step 6 if your truck has already had the locating slugs removed.



4. They make a tool for removing the locating slugs or you can knock them out with an air chisel. It is best to use a blunt tool in the air chisel to knock them out. If you are having a shop align your truck, they will have the tool needed to knock the slugs out.



StrongArm Installation

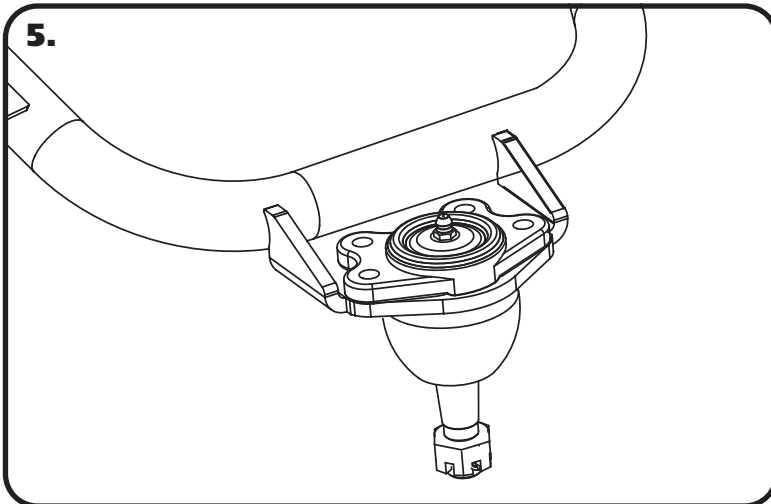

5. Install the Ball Joint using the supplied 5/16" Hardware. Insert the ball joint into the arm using **Image 5** as a reference. Insert a 5/16"-18 x 1 1/4" Bolt through the ball joint and plate. The threads should pointing the same direction as the ball joint pin. Install a 5/16" Flat Washer and 5/16"-18 Nylok Nut on the threads of each bolt. Torque to 25 ftlbs.



6. Insert the control arm into the OEM location. **The Brake Line Tab is positioned to the front of the vehicle. Use the Illustration on page 2 to help aid in installing the correct control arm in the correct location.**



7. Bolt the arm to the frame using the factory camber bolts. If you marked the bolts during disassembly, reinstall them in the correct position and tighten. Torque to 140 ft-lbs.



StrongArm Installation



8. Slide the ball Joint pin into the spindle and install the castle nut on each one. Torque the ball Joint nuts and install cotter pins in each one.

Ball Joint nut Torque Specs:

Torque to 50 ft lbs and then tighten nut to align cotter pin hole not exceeding 90 ft lbs.



9. Attach the ABS cable to the control arm by removing the nut/washer from the front, inner bolt. Slide the bracket onto the bolt and replace the washer & nut. Torque the nut to 25 ftlbs.



10. Attach the brake line bracket to the new upper control arm using the supplied thread forming bolts. Align the bracket with the tab on the control arm. Attach it using the thread forming bolts supplied with the kit. These can be threaded in using a ratchet. Put downward pressure on the bolt while turning them. Torque them to 15 inlbs.

11. Tighten all fasteners.

12. Have the front end aligned.

Suggested Alignment Specs:

Camber:	Street:	-.5 degrees
Caster:	Street:	+3.0 to + 5.0 degrees
Toe:	Street:	1/16" to 1/8" toe in



Part # 11379300 - 1988-1998 C1500 Drop Spindles

Recommended Tools

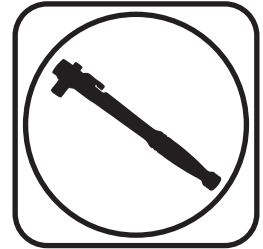

1988-1998 C1500 Drop Spindles Installation Instructions

Installation

Torque Specs:

Splash Shield to Spindle:	19 ftlbs
Upper Balljoint:	74 ft lbs and then tighten nut to align cotter pin.
Lower Balljoint:	94 ft lbs and then tighten nut to align cotter pin.
Outer Tie Rod:	46 ftlbs and then tighten nut to align cotter pin.

THESE SPINDLES ARE DESIGNED FOR THE HEAVY DUTY BRAKES, 1 1/4" THICK ROTORS.

NOTE

These spindles will increase your vehicle's track width by .200" per side.

15" wheels may require trimming of OEM lower control arms.



Part # 11379120 - 1988-1998 GM C1500 Front SwayBar



Recommended Tools



1988-1998 GM C1500 Front SwayBar Installation Instructions

Table of contents
Page 18..... Included Components and Hardware List
Page 19..... SwayBar Installation

Hardware Torque Specifications

M10-1.5.....	37 ftlbs
--------------	----------

Major ComponentsIn the box

Part #	Description	QTY
90001228	Front Sway Bar	1
90001258	Sway Bar End Link T-Bushing	4
70015016	Lined Sway Bar Bushing	2
90001346	Bushing Strap	2
90001257	Bushing Mount Adapter	2
70014491	Locking Ring	2

END LINK ASSEMBLY

Part #	Description	QTY
90003543	90 Degree End Link Spacer	2
90003842	90 Degree End Link	2
99115003	M10-1.5 x 115mm Fully Threaded Stud	2
90002930	End Link Kit	2
99112002	M10-1.5 Nylok Nut	2

HARDWARE KIT99010086

QTY	Part Number	Description
ADAPTER PLATE		
2	99111001	M10-1.5 x 30mm Flat Head
1	90002263	Red Loctite

QTY	Part Number	Description
BUSHING STRAP		
2	99111019	M10-1.5 x 40mm SHCS
2	99111018	M10-1.5 x 20mm SHCS
4	99113001	M10 Split Lock Washer
4	99113002	M10 Flat Washer

Getting Started.....

This sway bar kit utilizes a anti-friction lining in the sway bar bushing. The lining allows the sway bar to move freely and quietly in the bushing. No lubrication is required.

1. Jack the vehicle up to a safe working height and support with jack stands. Make sure the jack stands are stable before working under the car.
2. Remove the stock sway bar.



OEM FRAME BRACKET NOTE:

*Some 88-98 C1500's have an OEM frame bracket on the passenger side that the sway bar bushings attaches to. This bracket **MUST** be used with the Ridetech sway bar!*



4.

4. Open the sway bar bushing at the split and slide it **OVER** the swasy bar. Do this for both bushings.



5.

5. Slip the Bushing Straps over the Sway Bar Bushings.

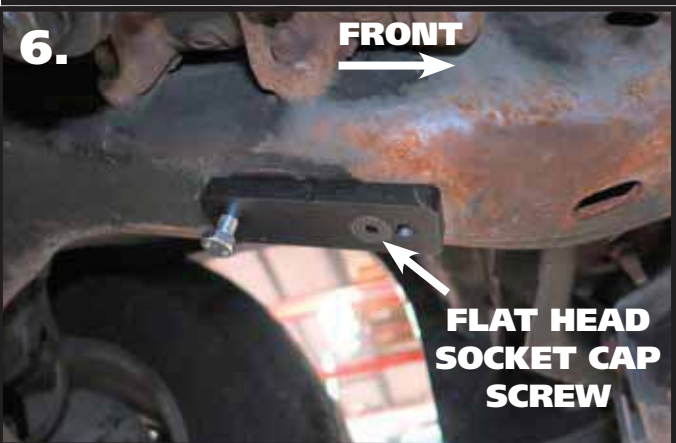

6.

FRONT
→

FLAT HEAD
SOCKET CAP
SCREW

6. Hold the Frame Plate up to the OEM holes, the Counter Sunk hole will be positioned over the front hole with the slot to the rear. Apply Red Loctite to the Flat Head Bolt. Thread a Bolt into the rear hole to help keep the plate straight. Torque the flat head bolt and remove the rear bolt.



7.

7. Slide the SwayBar into position on the truck with the SwayBar arms above the tie rods. Install a Lock Washer & Flat Washer on the each M10 Hex Bolts. A 30mm goes in the front, with a 40mm going in the rear. Do **NOT** complete tighten the hardware at this time.



8.

8. Install a T-Bushing on each of the 90 degree end links. The t-bushings are installed with the large diameter against the shoulder of the end link.



9.

9. Insert the 90 degree end link/t-bushing into the swaybar end with the threads pointing toward the coilspring. Install a 2nd t-bushing with the small diameter into the swaybar. Install the nut and torque. Do this for both sides.

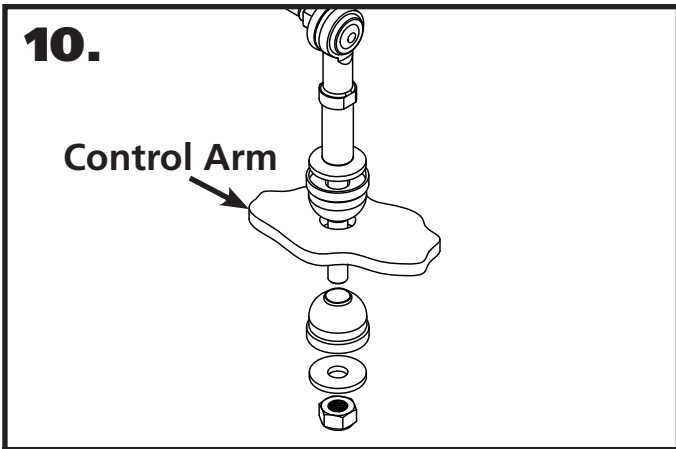

10. Install the End Links using **Diagram 10** as a reference. Install both end links before tightening the end link hardware. Tighten the end link nut until it is flush with the end of the bolt, and then tighten it 2 more complete rounds.



11. Center the swaybar and torque the strap hardware. Install the stop rings against the swaybar bushing. The stop rings will go against the inner side of the bushing. Take the stop rings apart and reassemble them against the bushing and tighten.



Part # 11377199

1988-1998 C1500 Rear Bolt-On Wishbone Suspension System

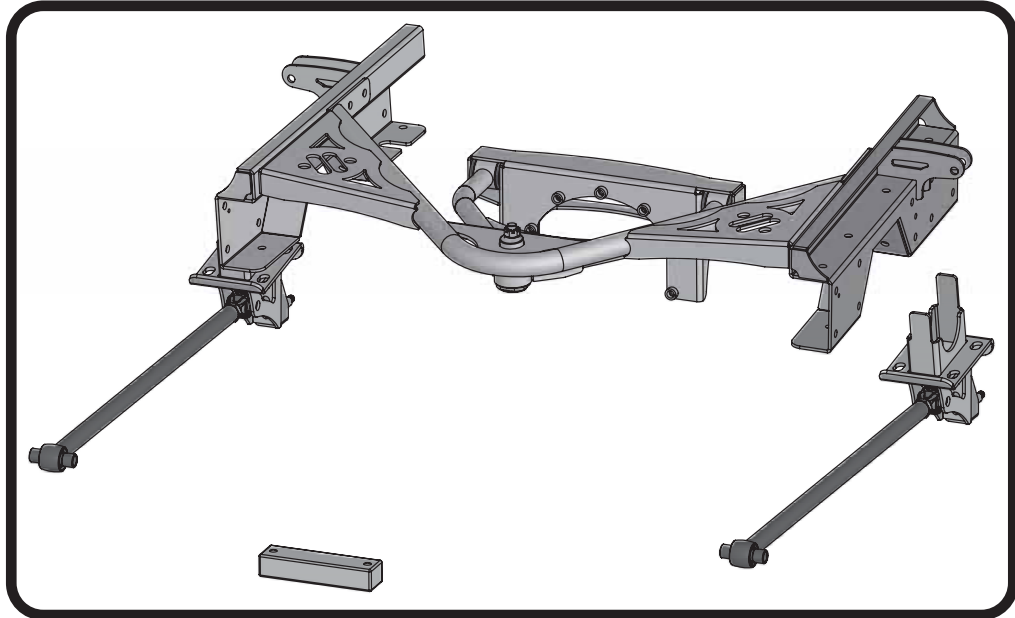

Recommended Tools

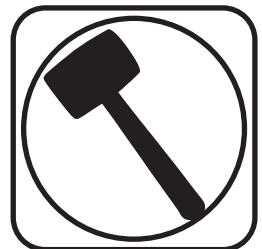

1988-1998 C1500 Rear Suspension Installation Instructions

Table of contents

Page 22-23.....	Included Components
Page 24.....	Hardware List & Disassembly
Page 25.....	Disassembly & Getting Started
Page 26-28.....	C-Notch Installation
Page 29.....	Lower Axle Mount Installation
Page 30.....	Installing Lower Bars
Page 31.....	Installing Lower Bars & Wishbone Assembly
Page 32-33.....	Wishbone Axle Mount Installation
Page 34.....	Wishbone Installation
Page 35.....	Shockwave/CoilOver Mounting
Page 36.....	Carrier Bearing Mount
Page 37.....	E-Brake Cable Relocation
Page 38.....	Bed Modification





Major ComponentsIn the box

Item #	Part #	Description	QTY
1	90001271	Driver C-Notch	1
2	90001272	Passenger C-Notch	1
3	90001273	Rear Upper Control Arm Mount Crossmember	1
4	90001274	Rear Upper Wishbone	1
5	90001275	Rear Upper Control Arm Differential Mount	1
6	90001276	Lower Axle Bracket	2
7	90001277	Lower Bars - Set to 31 3/4"	2
8	90001329	Carrier Bearing Spacer - used on carrier bearing equipped trucks	1
9	70013364	RH R-Joint Threaded Housing	2
10	70002825	5/8" Shock Stud	2
11	90001624	Aluminum Lower Shock Mount	2
12	70013334	R-Joint Spacers - rear lower bar	4
13	70013768	R-Joint Spacer - Lower Bars - Front	4
14	70010759	Delrin Bushings - installed in upper control arm	4
15	90000549	Delrin Bushing Inner Sleeves - installed in upper control arm	2
16	90000895	Ball Joint - Upper Wishbone	1
17	99752004	3/4"-16 Jam Nut - Installed on Lower Bars	2
	90001082	Short Bump Stops with Hardware - Not Shown	2
	90003081	Brake Line Bracket - Not shown	1
	90002067	Lower Shock Bearing Spacers - Not Shown	4
	70013497	U-Bolt- 5/8-18 x 3.13 x 5 w/2" Thread - Not Shown	4
	70014580	Driver C-Notch Template - Not Shown	1
	70014581	Passenger C-Notch Template - Not Shown	1
R-Joint Components - (Installed in bar ends and front of wishbone)			
	70013279	Retaining Ring	4
	70013280	Wavo Wave Spring	4
	70013275	R-Joint Center Ball	4
	70013276	R-Joint Composite Center Ball Cage	4

New R-Joints will be quite stiff (75-90 in/lbs breakaway torque) until they "break in" after a few miles of use. After the break in period they will move much more freely. Because the composite bearing race contains self lubricating ingredients, no additional lubrication is needed or desired. Any additional lubrication will only serve to attract more dirt and debris to the R-Joint and actually shorten its life.



Major ComponentsIn the box

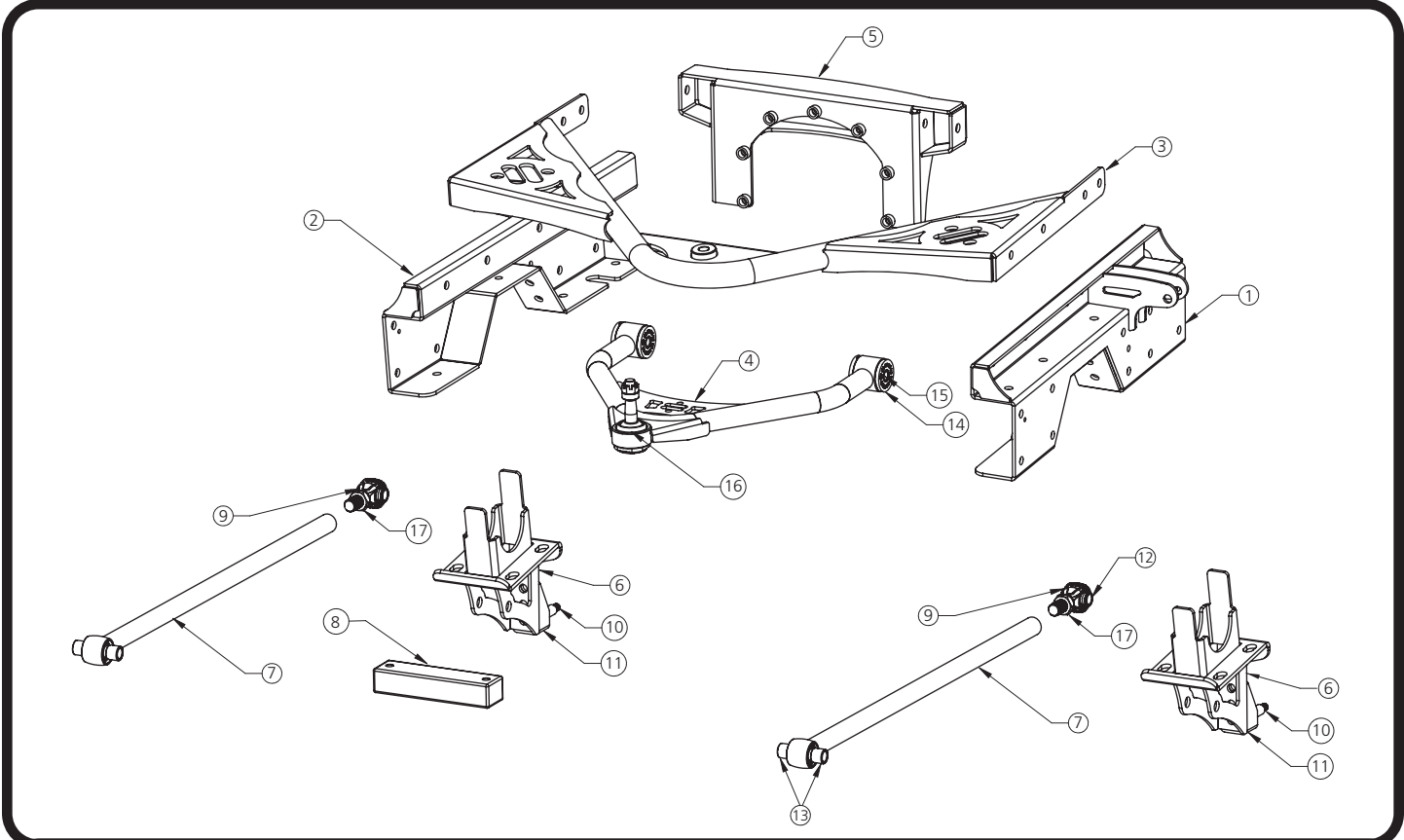

R-JOINT SPACER INSTALLATION

Install the Spacers by inserting the SMALL side of the SPACER into the Center Pivot Ball. Push them in until they bottom out and stop.

LOWER FRONT R-JOINT

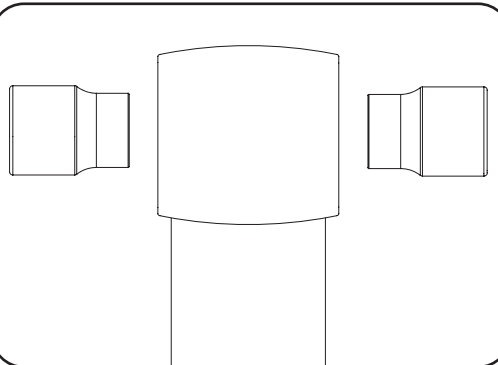

LOWER REAR R-JOINT

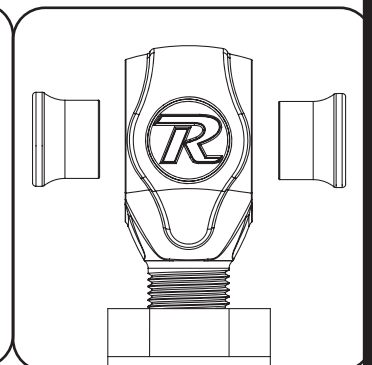

New R-Joints will be quite stiff (75-90 in/lbs breakaway torque) until they "break in" after a few miles of use. After the break in period they will move much more freely. Because the composite bearing race contains self lubricating ingredients, no additional lubrication is needed or desired. Any additional lubrication will only serve to attract more dirt and debris to the R-Joint and actually shorten its life.



Hardware ListIn the box (Kit# 99010087)

The Hardware Kit contains bags to help aid in selecting the correct hardware for the component being installed. The hardware list shows how the hardware is bagged.

QTY	Part Number	Description
"C" NOTCH MOUNTING		
1	99431022	7/16" x 1 1/2" USS Bolt
33	99431021	7/16" x 1 1/4" USS Bolt
34	99432010	7/16" USS Nylok Nut
68	99433005	7/16" SAE Flat Washer
UPPER CONTROL ARM CROSSMEMBER		
8	99431021	7/16" x 1 1/4" USS Bolt
8	99432010	7/16" USS Nylok Nut
16	99433005	7/16" SAE Flat Washer
AXLE BRACKET TO AXLE		
8	99622013	5/8" SAE High Nut
8	99623010	5/8" SAE Flat Washer
LOWER 4LINK BARS TO OEM MOUNT		
2	99561004	9/16"-18 x 5" GR8 Bolt
2	99562001	9/16"-18" Nylok Jam Nut
4	99566003	9/16" SAE Flat Washer
LOWER 4LINK BARS TO AXLE MOUNT		
2	99621004	5/8"-18 x 3" Gr. 8 Bolt
2	99622006	5/8"-18 Nylok Jam Nut
4	99623001	5/8" SAE Flat Washer
BRAKE LINE JUNCTION BLOCK		
1	99311003	5/16"-18 x 1 1/2" Hex Bolt
2	99313002	5/16" Flat Washer
1	99312003	5/16"-18 Nylok Nut
SHOCK STUD		
2	99432002	7/16"-20 Nylok Nut
2	99433002	7/16" SAE Flat Washer
2	99623004	5/8" SAE Flat Washer

QTY	Part Number	Description
UPPER CONTROL ARM DIFFERENTIAL MOUNT		
7	99315004	5/16"-18 x 2 1/4" Stud
7	99313001	5/16" SAE Flat Washer
7	99312002	5/16"-18 Nylok Nut
2	99312007	5/16"-18 Hex Nut
1	90002263	Red Loctite
UPPER CONTROL ARM MOUNTING		
2	99501025	1/2"-13 x 3 1/4" Hex Bolt
2	99502009	1/2"-13 Nylok Nut
4	99503014	1/2" SAE Flat Washer
LOWER SHOCK MOUNT		
2	99501019	1/2"-13 x 1 1/4" Hex Bolt
2	99501046	1/2"-13 x 1 3/4" Hex Bolt
4	99502001	1/2"-13 Nylok Nut
4	99503001	1/2" SAE Flat Washer
UPPER SHOCK MOUNTING		
2	99501064	1/2" x 2 3/4" USS Bolt Gr. 8
2	99502009	1/2" USS Nylok Nut Gr. 8
4	99503014	1/2" SAE Flat Washer Gr. 8
CARRIER BEARING MOUNT		
2	99371062	3/8"-16 X 2 1/2" Hex Bolt
2	99372002	3/8"-16 Nylok Nut
4	99373003	3/8" SAE Flat Washer
BRKE LINE FRAME BRACKET		
1	99311033	5/16"-18 X 1 1/2" Button Head
2	99311011	5/16"-18 x 1 1/4" Hex Bolt
6	99313001	5/16" SAE Flat Washer
3	99312007	5/16"-18 Nylok Nut

Disassembly

Congratulations on your purchase of the Ridetech Rear Wishbone System. This system has been designed to give your truck excellent handling along with a lifetime of enjoyment. Some of the key features of this system: C-notches to give your suspension the travel it needs at the lowered height, 3Link setup to replace the leaf spring and provide better control of the rear axle, upper wishbone to eliminate the side-to-side movement of the differential, and the biggest feature of all, it allows the use of ShockWaves or CoilOvers.

Note: This system is designed for use with the Ridetech ShockWaves or CoilOvers. **The factory shocks and springs or the factory sway bar will not fit this 4Link.**



Disassembly

1. Raise the vehicle to a safe and comfortable working height and support it by the frame. You will need to be able to move the rear differential up and down. Use a jack under the rear axle so it can be raised and lowered as needed during the install.
2. **Remove the bed, retaining the hardware for reassembly. This kit can NOT be installed with the bed on. The bed requires minor modifications before reinstalling.**
3. Remove the leaf springs and shock absorbers. Refer to the factory service manual for proper disassembly procedures.

Getting Started.....



4. The brake line/wire clamp will need to be removed from the inside of the driver side frame rail. This will allow you to move it out of the way when cutting the frame for the c-notch.



5. Unbolt the brake line bracket from the inside of the driver side frame rail.



"C" Notch Installation

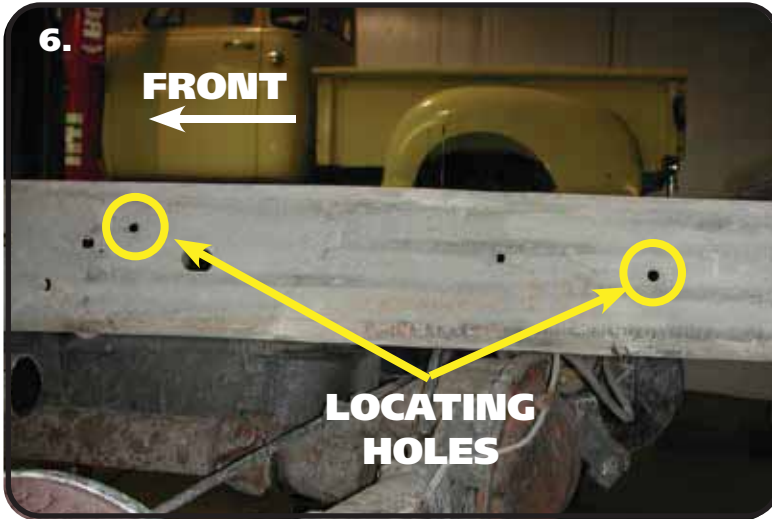

6. To allow maximum drop on this truck, the frame must be notched. The template for the notch will locate off of the 2 existing holes. **Image 6** illustrates the holes used. Use the supplied "C" Notch template to mark out the frame for cutting. Before cutting out the frame, support the frame in front of and behind the "C" Notch area. We suggest doing one side at a time.

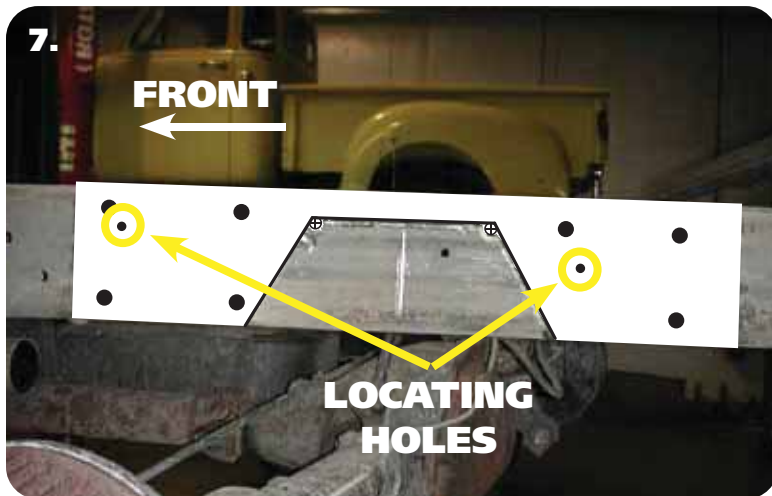

7. Use the supplied Template to mark the cut lines on the frame. Center Punch the "⊕" in the corners of the cut area.

NOTE: IF YOU WOULD HAPPEN TO NEED A NEW TEMPLATE, IT CAN BE FOUND ON OUR WEBSITE. GO TO www.ridetech.com, ENTER THE KIT NUMBER IN THE SEARCH BAR. THE TEMPLATE CAN THEN BE DOWNLOADED OR PRINTED.

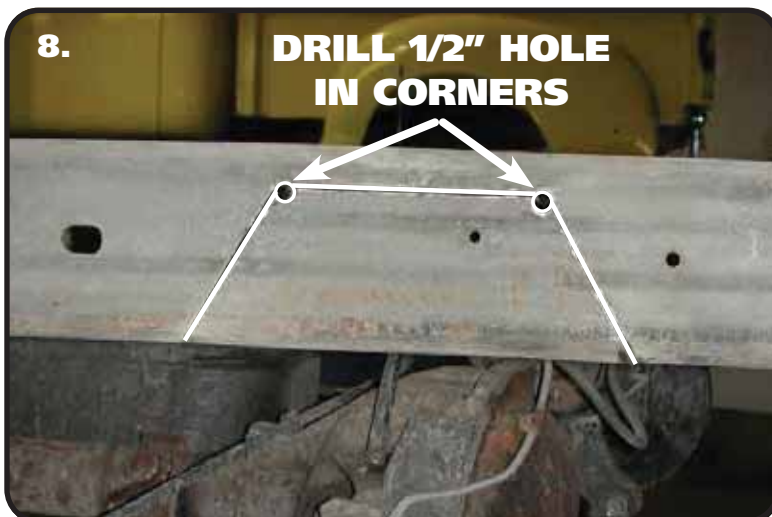

8. Drill out the two corners with a 1/2" drill bit. This will give the cut a round edge and eliminate the possibility for stress fractures. Then cut the notch with a saw-z-all, cutoff wheel, or plasma cutter. Grind all edges smooth. Check the inside of the frame for wires or lines before drilling or cutting.



"C" Notch Installation

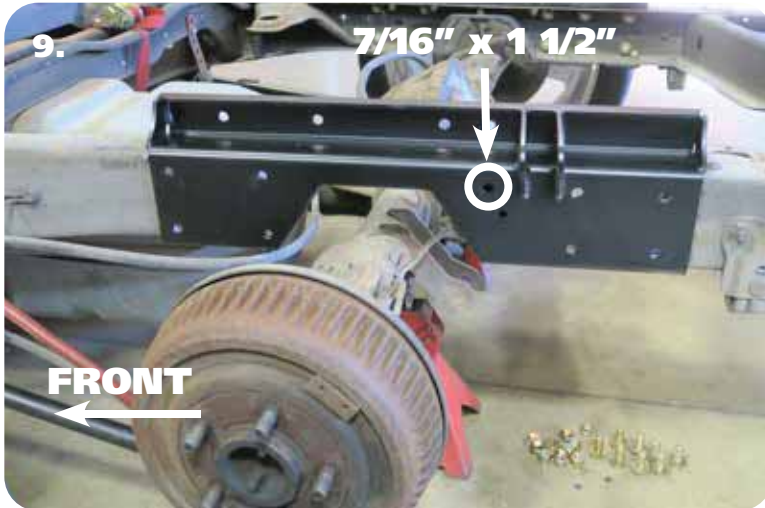

9. Slip the C-Notch over the frame rail. Use the C-Notch as a template to drill the (9) holes in the side of the frame. Use a 7/16" drill bit to drill the holes. The side holes use 7/16"-14 x 1 1/4" bolts except for the circled hole in **Image 9**, it uses 7/16"-14 x 1 1/2". The passenger side uses all 7/16"-14 x 1 1/4". Install a 7/16" Flat Washer on each of (9) 7/16"-14 Bolts. Insert a bolt/washer in each hole. Install a 7/16" Flat Washer and 7/16"-14 Nylok Nut on the threads of each bolt/washer and tighten. Torque the hardware to 50 ftlbs.

IT IS IMPORTANT TO TIGHTEN THE SIDE HARDWARE BEFORE DRILLING THE TOP AND BOTTOM HOLES.

10. Bolt the Bumpstop into the C-notch using the hardware included on the bumpstop.

REPEAT STEPS 6-10 for the 2nd C-Notch.

STEPS 11-13 ARE DRIVER SIDE ONLY!

11. Drill out the small rear locating hole to 5/16". Also, remove the nut from the 7/16" Bolt above the small hole. Insert a 5/16"-18 x 1 1/4" BUTTUN HEAD into the drilled hole.

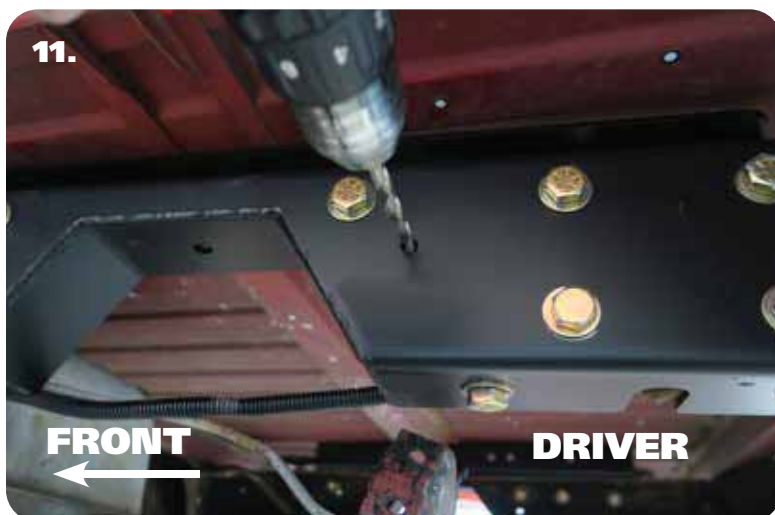



"C" Notch Installation



12. Slip the Brake Line Bracket over the 7/16" and 5/16" Bolts sticking through the back side of the frame. Install a Flat Washer & Nut on each and tighten.



13. Install a 5/16" Flat Washer on each of (2) 5/16" x 1 1/4" Bolts. Install the bolts/washers in the Brake Line Bracket and slip the OEM brake line bracket over the (2) bolts. Install a 5/16" Flat washer & 5/16" Nylok Nut on each bolt and tighten.



14. Use a 7/16" Drill bit to drill the remaining holes in the top and bottom of the frame. Install a 7/16" Flat Washer on the remaining 7/16" x 1 1/4" Bolts. Insert bolt/washers in the drilled holes of the c-notch. Install a 7/16" Flat washer and 7/16" Nylok Nut on the threads sticking through the c-notch/frame. Torque the hardware to 50 ftlbs.



Lower Axle Mount Installation



15. Insert the upper wishbone crossmember between the c-notches. The bung in the center of the cross member is tapered, the large side of the taper will need to be down. The gusset in the center will also be bent downward. Insert the cross member in position, lining up the 4 holes in the side flanges with the 4 bolt holes in each c-notch. Install a 7/16" flat washer on each of (8) 7/16"-14 x 1 1/2" bolts. Line up bolt holes and insert a bolt/washer in each one. Install a 7/16" flat washer on the threads of the bolts that is sticking through the flanges. Torque to 50 ftlbs.

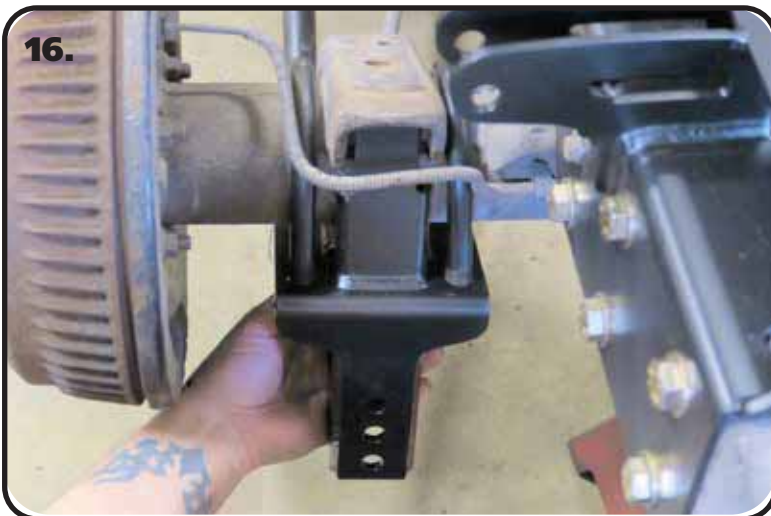

16. The Axle Mounts are the same for driver and passenger sides. Install a supplied 5/8" U-bolt on each side of the OEM leaf spring pad. Slide an Axle Mount on the U-bolts with the top tabs inserted into the leaf spring pad. Hold the mount in place and install a 5/8" Flat Washer and 5/8" High Nut on the threads of the u-bolts sticking through the axle mount. Tighten the nuts evenly in a criss-cross fashion making sure the tabs of the axle mount are touching the leaf spring pad evenly. Torque the nuts in a criss-cross fashion to 60 ftlbs. Repeat on the other side.



17. The Lower Shock Mount attaches with (1) 1/2"-13 x 1 1/4" Hex Bolt, (1) 1/3"-13 x 1 3/4" Hex Bolt, & (2) 1/2" Flat Washer, & (2) 1/2"-13 Nylok Nuts. The Lower Mount gets attached to the 2nd and 3rd hole up from the bottom of the Axle Mount. When the Shock Mount is installed correctly, the bottom of the Lower Shock Mount is approx. 3/8" below the bottom of the Axle Mount. Insert the Bolts through the Aluminum Shock Mount with the 1 1/4" long bolt in the top hole, 1 3/4" in the bottom hole. Insert the bolts through the Axle Mount and install the Flat Washers & Nylok Nuts on the Threads sticking through. Repeat on both sides and torque the Bolts/Nuts to 75 ftlbs. Install a 5/8" Flat Washer onto the 5/8"-18 threads of the shock stud. Apply Red Loctite to the 5/8" threads of the stud. Thread the Shock Stud into the threaded hole of the Lower Mount. Repeat on both sides and torque the Shock Stud to 65-75 ftlbs.



Installing Lower Bars

18.



18. Insert (2) Narrow R-Joint Spacers into each side of the R-Joint with the small OD inserting into the R-Joint.

19.



19. Insert the Rear Lower Bar R-Joint into the Lower Axle Bracket. Line up the through hole of the R-Joint with the of holes of the Axle Bracket.

20.



20. Install a 5/8" Flat Washer on to a 5/8"-18 x 3" Hex Bolt, insert into the lined up holes. Install a 5/8" Flat Washer followed by a 5/8"-18 Thin Jam Nylok Nut. Repeat on both sides and tighten the Bolts/Nuts enough to eliminate any gaps.



Installing Lower Bars & Wishbone Assembly



21. Insert the long R-Joint Spacers into the front of the lower bar with the small OD inserted into the R-joint. Insert the Front Lower Bar R-Joint into the Front Leaf Spring Mount. Line the through hole of the R-Joint with the of holes of the leaf spring mount. Install a 9/16" Flat Washer on to a 9/16"-18 x 5" Hex Bolt, insert into the lined up holes. Install a 9/16" Flat Washer followed by a 9/16"-18 Thin Jam Nylok Nut. Repeat on both sides and tighten the Bolts/Nuts enough to eliminate any gaps.



22. Insert the rear of the Wishbone into the Axle Bracket lining up the holes. The ball joint pin needs to be pointing UP. Use **Images 22 & 23** to assist you with positioning of the ball joint pin. Install a 1/2" Flat Washer on each of (2) 1/2"-13 x 3 1/4" Bolts. Insert them into each Bracket/Bushing hole from the outside with the threads pointing to the center. Install a 1/2" Flat Washer and 1/2"-13 Nylok Nut on the threads of each bolt and tighten to 50 ftlbs.



23. **Image 23** illustrates a correctly installed upper wishbone.



Wishbone Axle Mount Installation



24. Remove the bolt that attaches the brake line junction block to the bracket. The junction block will be reattached later.

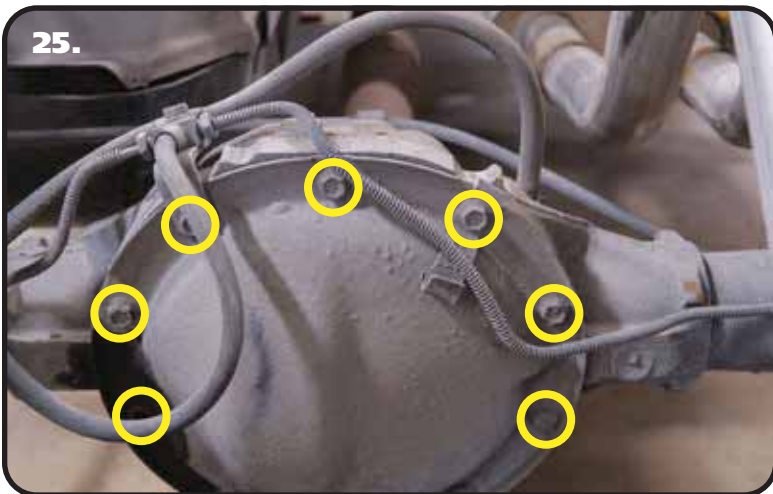

25. Remove the top (7) bolts of the differential cover leaving in the bottom (3).

IF THE DIFFERENTIAL COVER HAS A GASKET BETWEEN IT AND THE HOUSING, IT WILL NEED TO BE REMOVED AND SEALED WITH RTV SEALANT. Be sure to refill the differential with the correct gear oil before driving.

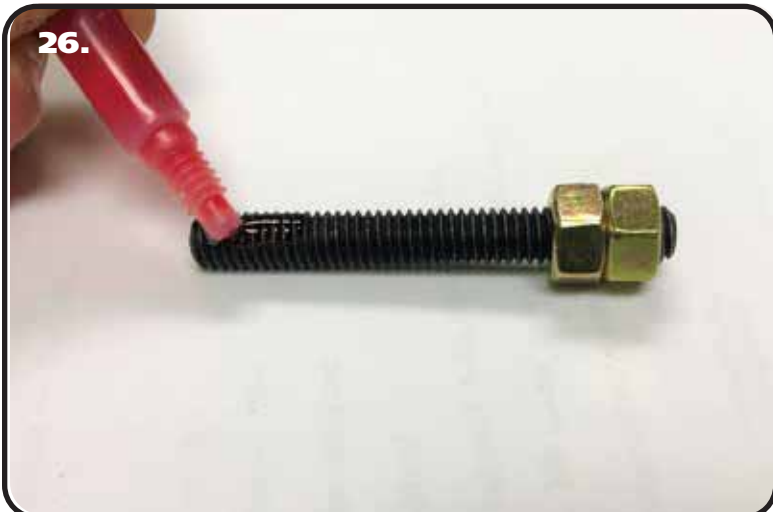

26. The 7 OEM bolts that were removed from the top of the differential cover will be replaced with 5/16"-18 x 2 1/4" Studs. These Studs and the nuts used to install them are supplied in the Hardware Bag labeled "Upper Wishbone Differential Mount". Thread the (2) 5/16"-18 Hex Nuts on one of the studs. Using (2) wrenches, tighten the nuts against each other locking them together. Apply Red Loctite to the other end of the stud.



Wishbone Axle Mount Installation



27. Thread the Stud into one of the 7 threaded holes in the axle housing. Torque the Stud to 25 ftlbs. Use 2 wrenches to unlock the nuts from each other and remove them from the stud. Repeat the process on the remaining 6 studs.



28. Position the Axle Bracket/Wishbone in place with the wishbone to the front of the truck. Line up the (7) holes in the axle bracket with the (7) threaded studs of the Differential.



29. Using the Hardware Bag "Upper Wishbone Differential Mount", install a 5/16" Flat Washer & 5/16"-18 Nylok Nut on each of (7) 5/16" Studs. Torque to 25 ftlbs



Wishbone Installation



30. Using the Hardware Bag "Brake Line Junction Block", install a 5/16" Flat Washer on a 5/16"-18 x 1 1/2" Bolts. Insert the bolt/washer through the junction block and mounting hole in the differential bracket. Install a 5/16" Flat Washer & 5/16"-18 Nylok Nut on the threads of the bolt. The brake lines will need to be tweaked to get the distribution block in position. Torque the bolts to 25 ftlbs.



31. Install the Rubber Boot on the Ball Joint. **If the rubber boot has a plastic protector on it, discard the plastic protector.** Insert the ball joint pin into the opening of the upper bridge. Push it up in the hole and install the castle nut supplied in the kit.



32. Torque the ball joint nut to 50 ftlbs. Verify if the hole in the ball joint pin aligns with any of the slots of the castle nut. Tighten the castle nut to align them. **DO NOT LOOSEN THE CASTLE NUT.** Install the supplied cotter pin. Thread the grease zerk into the ball joint and grease it.



Shockwave/Coilover Mounting



33. Insert the 1/2" ID Shock Bearing Spacer into each side of the ShockWave/CoilOver Bearing. Install a 1/2" Flat Washer on a 1/2"-13 x 2 3/4" Bolt. If installing ShockWaves, insert the top of the shock into the shock mount on the c-notch with the adjusting knob to the outside. If installing CoilOver, insert the bottom of the shock into the shock mount on the c-notch. Line up the holes and insert the bolt/washer. Install a 1/2" Flat Washer and 1/2"-13 Nylok Nut on the threads and tighten to 50 ftlbs.



34. The Shock Stud requires spacers that are .400" long (90002067). Install a 5/8" ID 90002067 spacer (**Small side towards shock body**) onto the lower Shock Stud. Slide the bottom of the Shock onto the Stud. Install a second 5/8" ID 90002067 Spacer onto the Stud (**small side towards shock**). You may need to jack the rearend up to Slide the Shock onto the Stud.

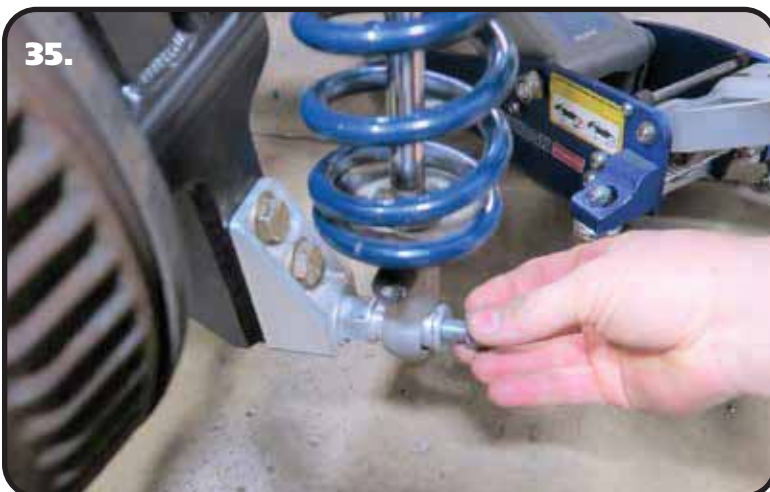

35. Install the 7/16" Flat washer and 7/16" Nylok nut. Tighten the upper and lower shock bolts. Torque the Upper Bolt to 50 ftlbs and the Lower Nut to 40 ftlbs. The designed ride height of the CoilOver/Shockwave is 14 1/2" center to center.



Carrier Bearing, Emergency Brake Cable Relocation



36.

**TRUCKS WITH CARRIER BEARINGS ONLY!
IF YOUR TRUCK DOESN'T HAVE A CARRIER
BEARING, SKIP TO STEP 38**

36. The driveshaft carrier bearing will need to be relocated to optimize driveline angles at your new lower ride height. Unbolt the carrier bearing.



37.

37. Install carrier bearing spacer between carrier bearing housing and cross member. Secure with 3/8" x 2 1/2" bolts, 3/8" flat washers, & 3/8" nylok nuts.



38.

38. On some years, the emergency brake cable mounting will need to be modified for clearance. If your cable mount on the snout of the differential looks like **Image 38**, no changes will be needed. If it looks like **Image 39**, the mount will need to be flipped around.



Emergency Brake Cable Relocation, Bed Modification



39. If your emergency brake cable mount looks like **Image 39**, the mount will need to be flipped around. Start by removing the nut from the attaching bolt. Next, remove the bolt to detach the mount from the snout of the differential.



40. Use a flat bladed screwdriver to remove the mount from the emergency brake cable. Flip it around so that the bolt hole is to the rear of the truck. Use a pair of pliers to snap the mount back onto the cable.



41. Slip the mount back in position on the snout of the differential. Reattach it with the OEM hardware that was removed previously. Push the cable down as far as it will go before tightening the hardware. With it in position, tighten the hardware.



Bed Modification



42. Trimming of the bed brace that is in between the wheel wells is necessary to clear the c-notches and wishbone. We cut ours with a die grinder and cut off wheel. **Image 42** illustrates the bed brace cut out. The cut starts 3 1/2" from the end of the brace and runs all the way across leaving 3 1/2" on the other end. It needs to be cut even with the flange that attaches the brace to the bed floor.



43. Your bed brace should look like **Image 43** after cutting.



44. If you haven't already, install the bump stops into the c-notch above the axle using the 3/8" flat washer and 3/8"-16 nylok nut supplied. A bumpstop will need to be installed in each c-notch.

45. Reinstall the bed.

46. Set ride height on the truck. The ride height of the Shockwave/CoilOver is approximately 14 1/2". If you are using ShockWaves, this is done by changing the air pressure in the ShockWaves. If you are using CoilOvers, the ride height is done by using the adjuster nut for the coil spring. The coil spring on the CoilOver will have some preload in the spring to get ride height, this is normal.



Part # 11376510 - 88-98 GM C1500 Rear HQ Series CoilOvers

Recommended Tools

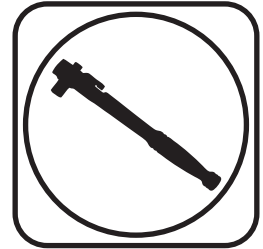

1988-1998 GM C1500 HQ Series Rear CoilOvers Installation Instructions

Table of contents

Page 40..... Included components

Page 41-42.... Assembly

Page 43-47.... Preloading, Ride Height and Shock Tuning

ShockWave Dimensions:

Center of bearing to Center of bearing:

Compressed: 11.23"

Ride Height: 14.50"

Extended: 16.43"





Major ComponentsIn the box

Item #	Part #	Description	QTY
1	892-10-805	5.2" Stroke HQ Series Shock	2
2	815-05-022-KIT	1.7" Shock Eyelet	2
3	803-00-199(kit)	Upper CoilSpring Retainer (803-00-199 kit)	2
4	59120200	Coilspring 12" 200lb	2
5	70010828	Delrin Spring Washer	4
6	803-00-199(kit)	Lower Spring Adjuster Nut (803-00-199 kit)	2
7	803-00-199(kit)	Adjuster Nut Locking Screw (803-00-199 kit)	2
8	803-00-199(kit)	Retaining Ring (803-00-199 kit)	2
9	90002043	1/2" ID Upper Bearing Spacers	4
	90001994	5/8" ID Bearing (installed in shock and eyelet)	4
	90001995	Bearing Snap Ring (installed in shock and eyelet)	8

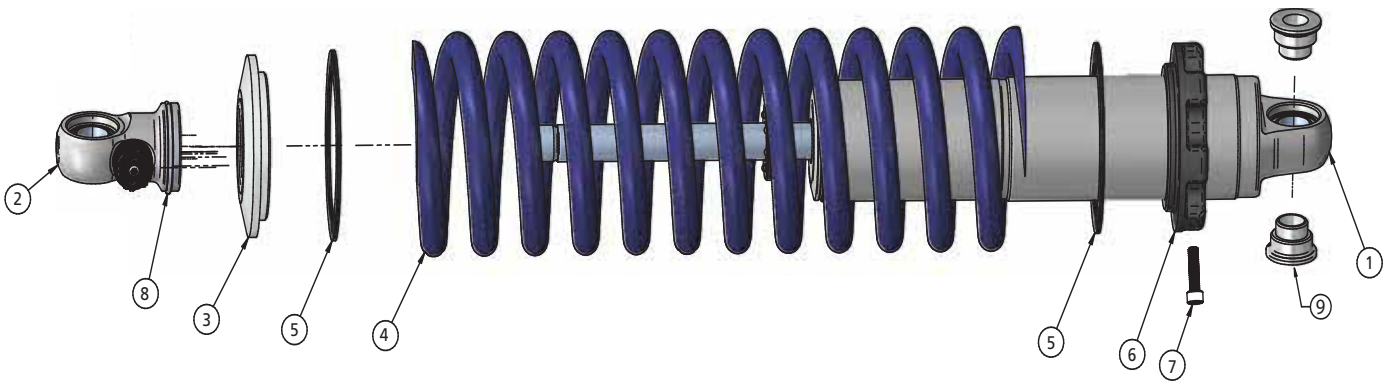



COILOVER ASSEMBLY INSTRUCTIONS



1. Thread the preload adjustment nut onto the shock from the bottom (Figure 1). A few threads of engagement is ok for now.



Figure 1

2. The rebound adjustment knob must be removed prior to installing the upper spring mount in step 4. Turn the adjustment knob clockwise until it stops, then remove the torx screw and the knob (Figure 2).



Figure 2

3. Slide a Delrin washer over the shock and onto the adjustment nut, followed by the coil spring (Figure 3).



Figure 3

4. With the adjustment knob removed, slide a Delrin washer over the eyelet and place on top of the coil spring, followed by the upper spring mount (Figure 4).



Figure 4



COILOVER ASSEMBLY INSTRUCTIONS



5. Slide the retainer clip over the upper eyelet and into the groove at the base of the eyelet. Make sure it snaps into place and is fully seated in the groove (Figure 5).



Figure 5

6. Reinstall the adjustment knob (Figure 6).

Once you have reinstalled the knob, you may want to turn the knob about 12 clicks counterclockwise since the rebound is currently set at "full stiff".



Figure 6

7. Thread the adjustment nut up the shock body to remove the slack and secure the spring and upper mount against the eyelet. Install the locking screw in the adjustment nut, but do not tighten yet (Figure 7). This screw will be tightened after your preload has been set.



Figure 7

8. Your assembled coilover is ready to be installed on the vehicle.



Figure 8

SETTING PRELOAD

1. Before adding any preload to your coilover, ensure that you are starting with zero preload on the spring. The adjustment nut should be snug against the coil spring, but not compressing it. The locking screw should be installed, but not yet tightened.



2. With zero preload on the spring, measure the distance from the bottom of the adjustment nut to the flat of the shock body. This is your starting point of reference.



3. Using a spanner wrench (Figure 3), apply preload by threading the adjustment nut up the shock an additional 1/2" from the measurement you took in Step 2. This is your initial preload setting.



4. Tighten the locking screw to secure the adjustment nut in its preloaded position. Torque to **18 in-lbs**.



ADJUSTING RIDE HEIGHT

NOTE: Optimal ride quality and handling typically occurs when the shock absorber is sitting between 40-60% of its full travel at ride height. However, measuring the shock can be difficult on some applications. If you do not wish to measure your shocks, an easier method that is still quite effective is to measure wheel travel. See Steps 1-4 below for this alternate method. If you've determined that your shock travel is good, you may skip to Step 5 to jump straight to making any necessary ride-height adjustments.

1. With coilovers installed and the preload set, lower the vehicle to the ground. With the entire weight of the vehicle on the wheels, jounce the suspension and roll the vehicle forward and backward to release any suspension bind.

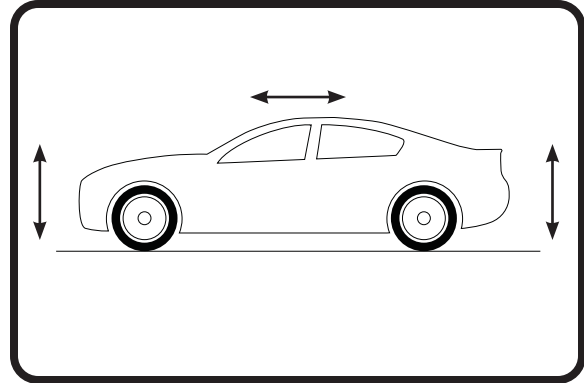

Figure 1

2. At the centerline of the wheel, take a measurement from the fender lip to the ground (Figure 2).

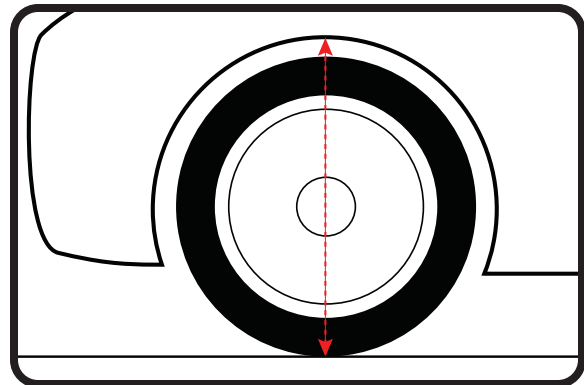

Figure 2

3. Lift the vehicle by the frame until the wheel is barely touching the ground. Take another measurement from the fender lip to the ground (Figure 3).

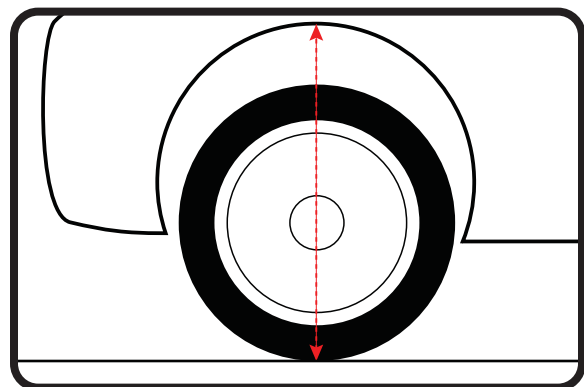

Figure 3

4. The difference between the measurements taken in Steps 2 and 3 is your **extension travel** at the wheel. A minimum of 1.5" of extension travel (at the wheel) is typically needed to prevent the shock from topping out. If you have more than 3" of extension travel, you may be at risk of bottoming out the shock and need to increase the ride height.

ADJUSTING RIDE HEIGHT

5. With coilovers installed and the preload set, lower the vehicle to the ground. With the entire weight of the vehicle on the wheels, jounce the suspension and roll the vehicle forward and backward to release any suspension bind. Evaluate your ride height.

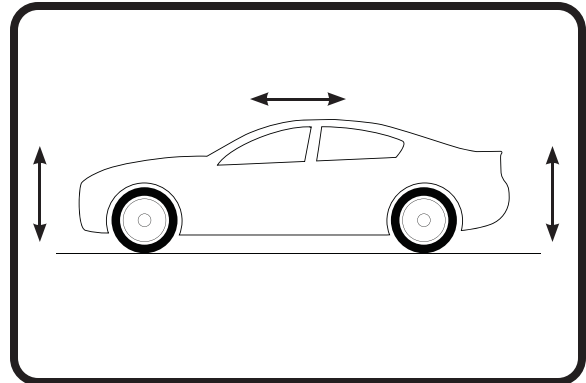

Figure 4

6. If you determine you need to adjust the ride height, raise the vehicle by the frame and allow the suspension to hang freely.

7. Loosen the locking screw on the coilover adjustment nut just enough to be able to turn the nut. **Do not remove the locking screw.** (Figure 5).



Figure 5

8. Measure the distance from the bottom of the adjustment nut to the flat of the shock body. We recommend recording this measurement for reference (Figure 6).

9. Using a spanner wrench, thread the nut up or down the shock body to achieve the desired ride height (Figure 7). Tighten the locking screw to secure the adjustment nut in place. Torque to **18 in-lbs.**



Figure 6

10. Lower the vehicle to the ground, jounce the suspension and roll the vehicle forward and backward to release any suspension bind.

11. Recheck your ride height. If you need to adjust, repeat Steps 6-10.

12. Once your desired ride height has been achieved, refer to the Shock Tuning Guide to dial in your shocks.



Figure 7



TUNING GUIDE

SINGLE-ADJUSTABLE SHOCKS



The Basics...

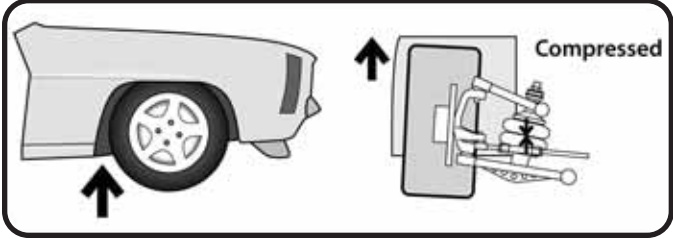

COMPRESSION

This typically occurs when you hit a bump in the road. The bump forces the wheel/tire/suspension assembly to "compress" or move upwards into the car.

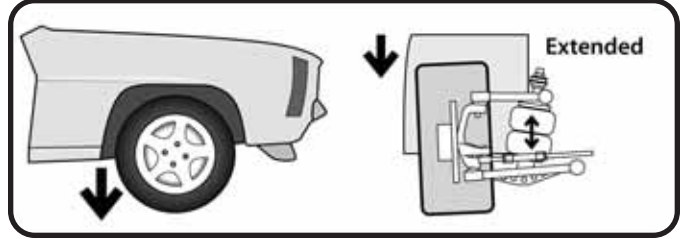

REBOUND

Rebound is the opposite of compression. This occurs when the wheel/tire/suspension assembly falls into a pothole, or simply "rebounds" from being compressed.

Where Are The Knobs?

HQ Series Shocks

- The adjustment knob is located on the top of the shock, either protruding from the side of the eyelet, or atop the stud.
- This knob provides rebound adjustment only.

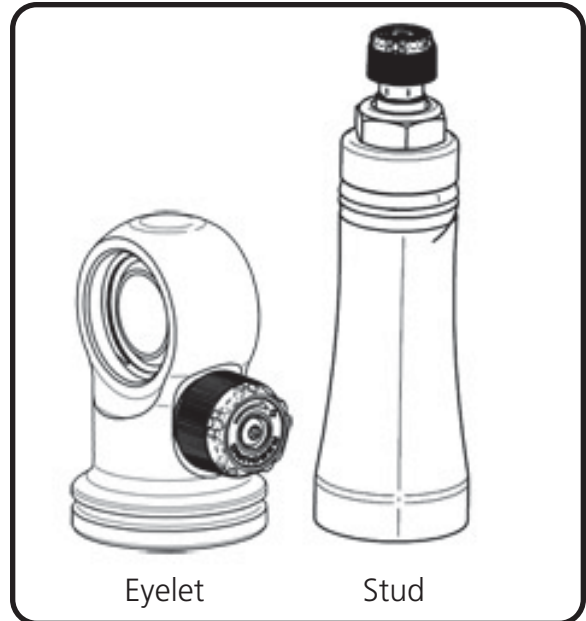

Knob Function

Counterclockwise

=
Softer

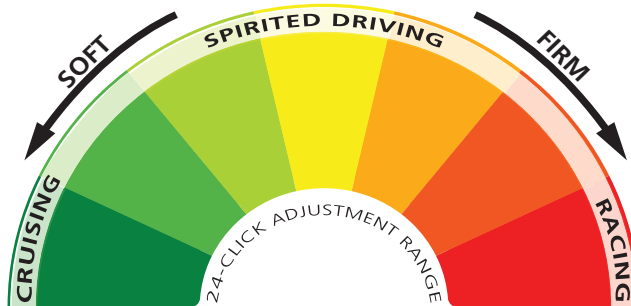

Clockwise

=
Firmer





TUNING GUIDE

SINGLE-ADJUSTABLE SHOCKS



Initial Rebound Setting

NOTE: Before jumping straight to a middle-of-the-road shock setting, we recommend you experience the full range of adjustment potential of your new shocks by first driving your vehicle at both the “full stiff” and “full soft” settings. Understanding how your shocks behave at these extremes will provide recognizable reference points as you attempt to dial in your settings.

1. Begin by setting your shocks to the “full stiff”, or minimal rebound position. You do this by turning the adjustment knob clockwise until it stops.

2. Now turn the adjustment knob counterclockwise 12 clicks. This is the approximate center of the adjustment range.

3. Take the vehicle for a test drive. Try to determine if you are experiencing any of the unwanted behaviors found at the extremes of the adjustment range. If you are satisfied with the ride quality and handling, you’re all set. Enjoy the ride!

4. If the vehicle feels too “floaty” or soft, turn the knob a few clicks clockwise to increase the damping effect.

If the ride quality is still too harsh or stiff, turn the knob a few more clicks counterclockwise to decrease the damping effect.

5. Take the vehicle for another test drive. If necessary, repeat the steps above until your desired optimal ride quality has been achieved.



General Guidelines

- The rear shocks typically have the most influence on ride quality. This is due to your seating position being closer to the rear than the front.
- Adjustments to the front shocks will generally require 3-4 clicks in any direction to be noticeable, while adjustments to the rear shocks may only require 1-2 clicks to be felt.
- Don’t be afraid to turn the knobs and experience the full adjustment range. You are not going to hurt anything and you can always go back if you adjust too far one way or the other.