



Part # 11380297 - 99-06 Silverado HQ ShockWave System

Front Components:

- 11382899 Front Lower StrongArms
- 11383699 Front Upper StrongArms
- 11389300 Front Spindles and Caliper Brackets
- 11383001 Front ShockWave
- 11389100 Front MuscleBar

Rear Components:

- 11387199 Rear StrongArm System
- 21150801 Rear ShockWave Instructions

Recommended Tools

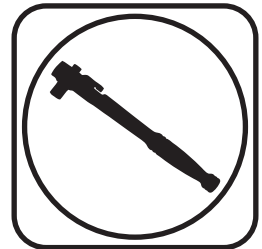

**99-06 Silverado ShockWave System
Installation Instructions**

Table of contents

- Pages 2-4..... Front ShockWaves
- Pages 5-8.....Lower StrongArms
- Pages 9-11..... Upper StrongArms
- Pages 12.....Spindles
- Pages 13-15..... Front MuscleBar
- Pages 16-37..... Rear 4Link
- Pages 38-39.....Rear ShockWaves
- Pages 40-41.....Care of your ShockWaves and Adjusting

THIS KIT WILL NOT WORK ON TRUCKS WITH TORSION BARS!!





Part # 11383001 - 99-06 Silverado Front HQ Series Shockwave

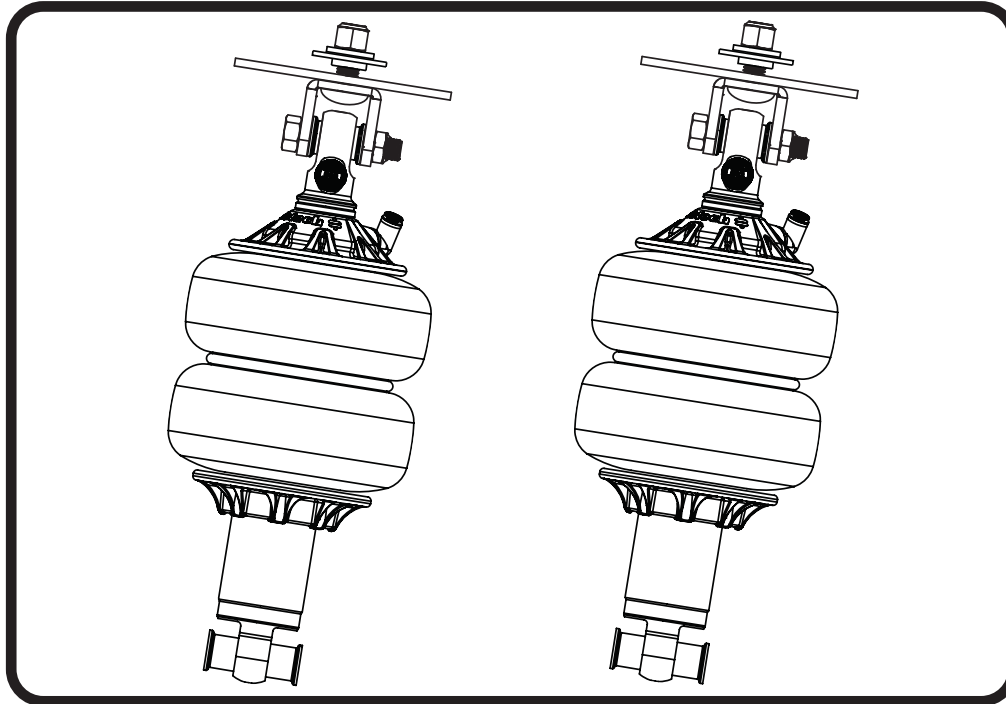

Recommended Tools

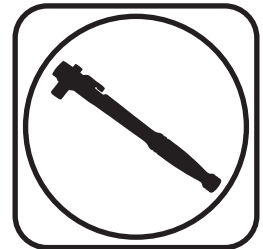

1000 Series Bellow, 1.7" Eye/Eye 4.1" Shock Installation Instructions

Table of contents

Page 3..... Included components

Page 4..... Shockwave Installation

ShockWave Dimensions:

Center of bearing to Center of bearing:

Compressed: 10.75"

Ride Height: 13.10"

Extended: 14.25"

www.ridetech.com
812-482-2932





Major ComponentsIn the box

Item #	Part #	Description	QTY
1	982-10-804	4.1" Stroke HQ Series Shock	2
2	815-05-022-KIT	1.7" Upper Shock Eyelet	2
3	24090199	6.5" Diameter Air Spring 1000 Series	2
4	234-00-153	Air Spring Locking Ring	2
5	99055000	Locking Ring Set Screw	2
6	90000097	Upper Mounting Plate	2
7	90002043	Upper Shock Bearing Spacers	4
8	90002062	Lower Bearing Spacers (INCLUDED WITH STROGARMS)	4
9	90000359	Upper Shock Mount T-Bushing	2
10	99501018	1/2"-13 x 1 1/2" Carriage Bolt	2
11	99501010	1/2"-20 x 2 1/4" Hex Bolt	2
12	99502003	1/2"-20 Thin Nylok Nut	2
13	99502001	1/2"-13 Nylok Nut	2
14	99503001	1/2" Flat Washer	4

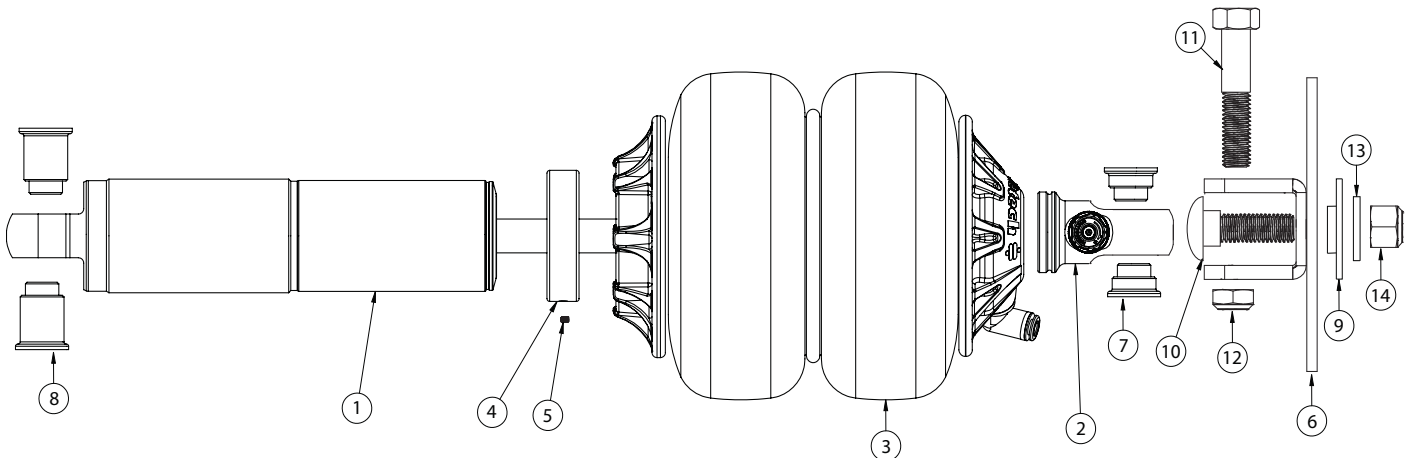

WARNING: ATTEMPTING TO REMOVE THE AIR FITTING WILL DAMAGE IT AND VOID THE WARRANTY.



ShockWave Installation

3.



4.



5.

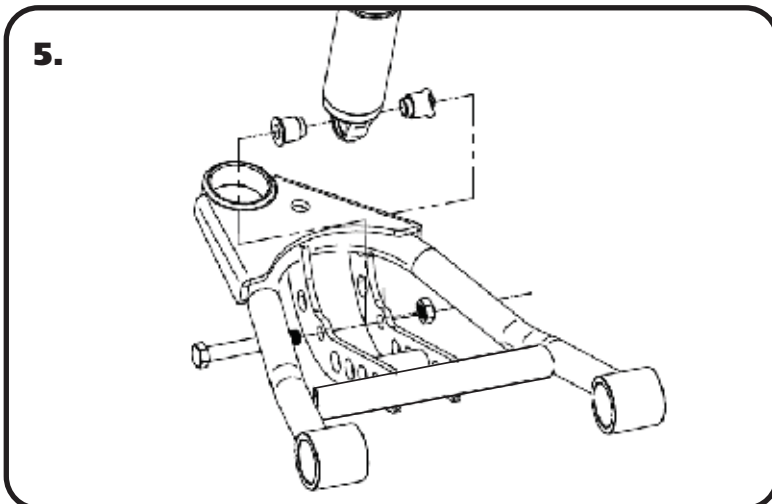

1. Raise and support truck at a safe, comfortable working height. Let the front suspension hang freely.

2. Remove the coil spring, shock absorber, bump stop, upper control arm, and lower control arm. Refer to factory service manual for proper disassembly procedure.

3. Insert the carriage bolt through the square hole in the upper mount. Insert a NARROW Bearing Spacer into each side of the Upper Eyelet. Slide the Eyelet of the ShockWave with the Spacers installed into the Upper Mount. Bolt the top of the ShockWave to the upper mount using a 1/2" x 2 1/4" bolt and Nylok jam nut.

4. Raise the Shockwave up to the coil spring mount with the carriage bolt sticking through the factory shock hole. The hole in the frame is larger than the bolt, so a step washer is supplied. This should be installed on top of the frame, followed by a 1/2" Nylok nut.

Note: The kidney bean shaped cutout in the upper bracket will match a protrusion in the coil spring pocket. This will clock the Shockwave so that when the suspension moves the bearing will rotate on the bolt. **If this is not installed properly it will damage the Shockwave.**

5. Raise the lower arm up to the Shockwave and bolt them together using the 1/2" x 3 1/4" bolt and Nylok supplied w/ the lower arms. An aluminum spacer will be on each side of the bearing. Torque to 75 ftbs.

6. Raise the lower control arm to full compression and double-check to make sure the Shockwave does not rub on anything at anytime. Allowing the Shockwave to rub on anything will cause failure and is not a warrantable situation.



Part # 11382899

1999-2006 Silverado Lower ShockWave/CoilOver StrongArms

Recommended Tools

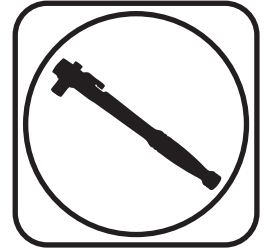

1999-2006 Silverado Lower StrongArms Installation Instructions

Table of contents

- Page 6..... Included components
- Page 7..... Getting Started
- Page 8..... PosiLink Installation

THIS KIT IS DESIGNED TO RAN WITH A 2" DROP SPINDLE.
RIDETECH PART #: 11389300

www.ridetech.com
812-482-2932





Lower Control Arm ComponentsIn the box

Item #	Part Number	Description	QTY
1	90000106	Driver Lower Control Arm (Shown)	1
1	90000107	Passenger Lower Control Arm	1
2	90000198	3.0" Inner Sleeve	4
3	90000199	3.5" Inner Sleeve	4
4	70010759	Delrin Bushing - with 2" Diameter Ledge	8
5	90002062	ShockWave/CoilOver Bearing Spacers	4
6	90000901	Lower Balljoint Assembly - Proforged # 101-10073	2
7	90000095	PosiLink T-Bushing	2
PosiLink Assembly			
8	90000921	12mm 90 Degree PosiLink	2
9	90000922	12mm Straight PosiLink	2
10	90000096	PosiLink Spacer	2
11	99125002	M12 - 1.75 x 65mm Threaded Rod	2
Hardware Kit # 99010212			
12	99502009	1/2" Nylok Nut	2
13	99501005	1/2"-13 x 3 1/2" Hex Bolt	2
14	99503014	1/2" SAE Flat Washer	2
15	99433002	7/16" Flat Washer	6
16	99122001	M12 - 1.75 Nylok Nut	4
17	99371014	3/8"-24 x 1 1/4" Hex Bolt	4
18	99372006	3/8"-24 Jam Nut	4

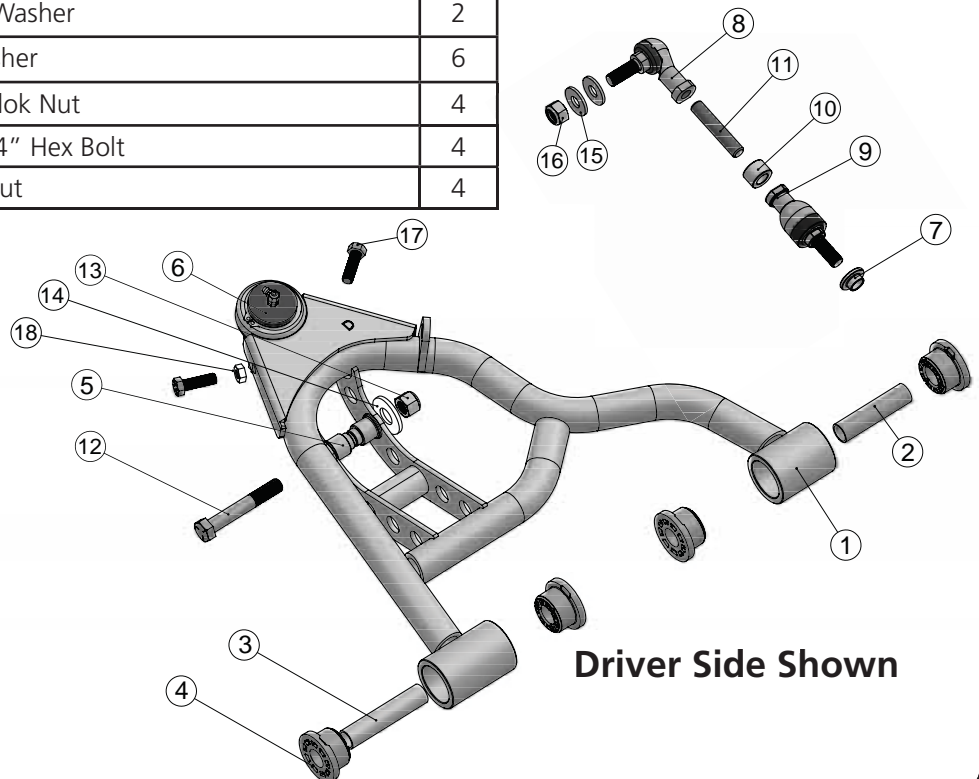



Getting Started.....

2.

SWAY BAR TAB

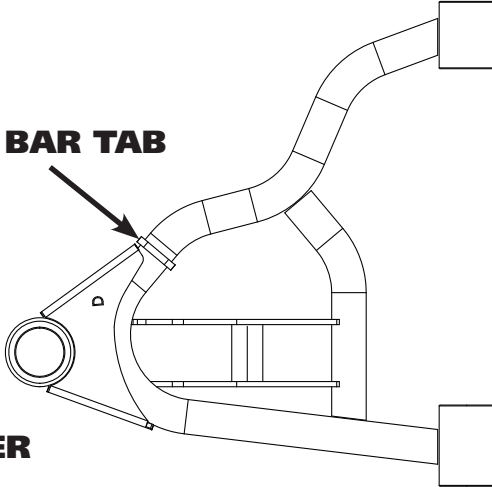

DRIVER

1. Remove the Lower Control Arms, CoilSprings, Shocks, and sway bars linkage. Refer to the factory service manual for disassembly procedure.

2. After removing the factory lower control arm, clean the bushing mounting surfaces on the frame. The Control Arms are marked "D" for Driver and "P" for Passenger. The Balljoint Pin points down and the Sway bar mount is on the front side of the arm. Fasten the lower arm to the frame with the OEM hardware. Torque to 120 ft-lbs.

Note: On some trucks the frame brackets may be pinched and will need to be spread back apart to allow the bushing to slide in.

3.

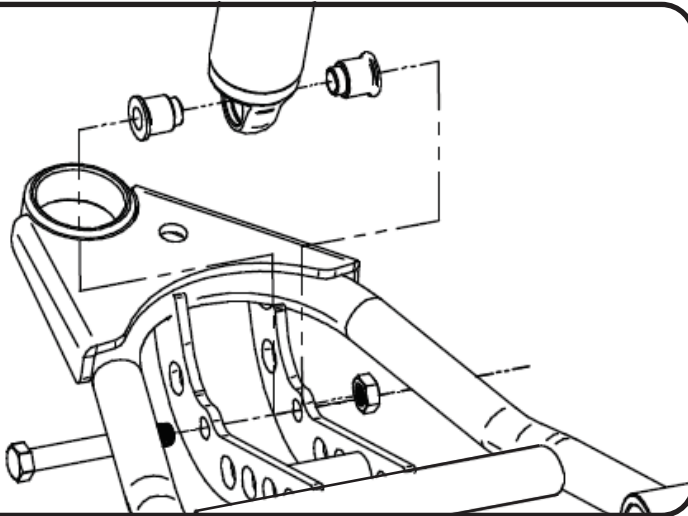

Install the ShockWaves/CoilOvers at this time. Refer to the CoilOver instructions for Assembly.

3. Insert the Bearing Spacers into the lower shock bearing. Swing the Control Arm up, line up the 1/2" holes with the bearing spacers, insert 1/2"-13 x 3 1/2" bolt. Install a 1/2" flat washer and nylok nut.

4.



4. Install the T-Bushing on the Straight PosiLink end with the Large OD against the PosiLink. Insert the assembly into the swaybar with the threads pointing up. Install a 7/16" Flat Washer followed by a M12-1.75 Nylok Nut. Torque to 50 ftlbs.



PosiLink Installation



5. Install a 7/16" Flat Washer onto the threads of the 90 Degree PosiLink. Insert the PosiLink into the swaybar tab on the control arm with the threads pointing to the FRONT of the truck. Install a 7/16" Flat Washer and M12 - 1.75 Nylok Nut and torque to 50 ftlbs.

5. **Image 6** illustrates the correct assembly and orientation of the PosiLink.

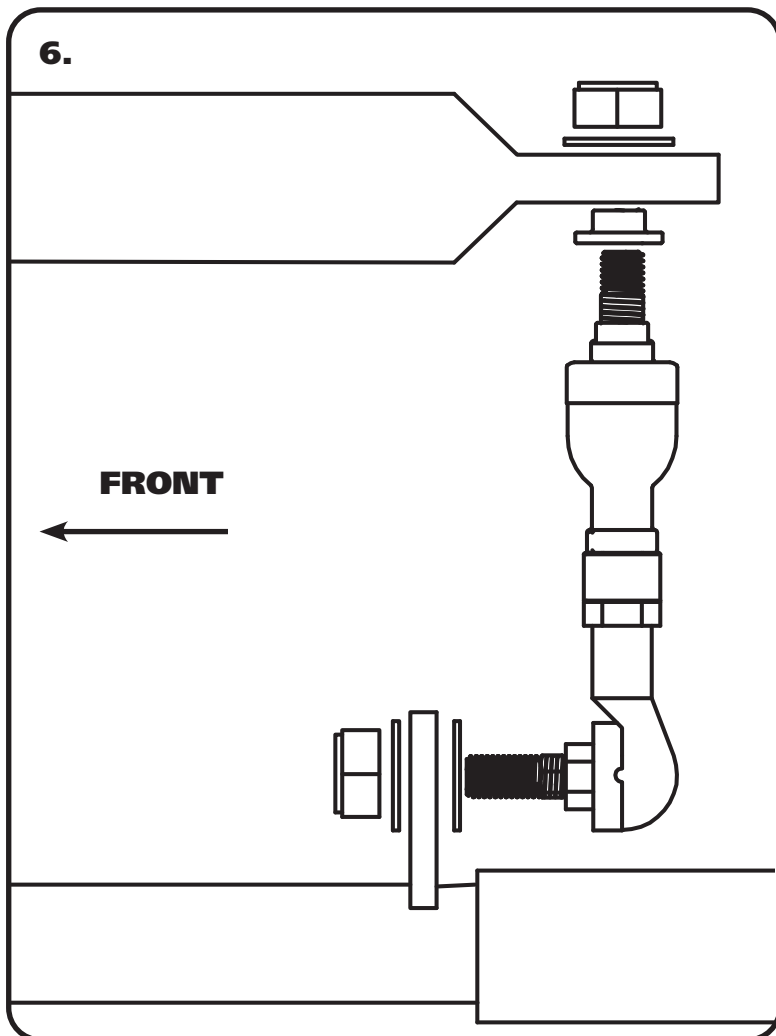



Part # 11383699

1999-2006 Silverado Upper StrongArms

Recommended Tools

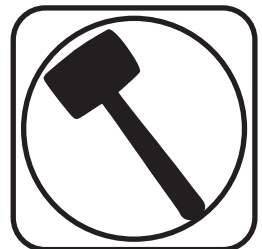
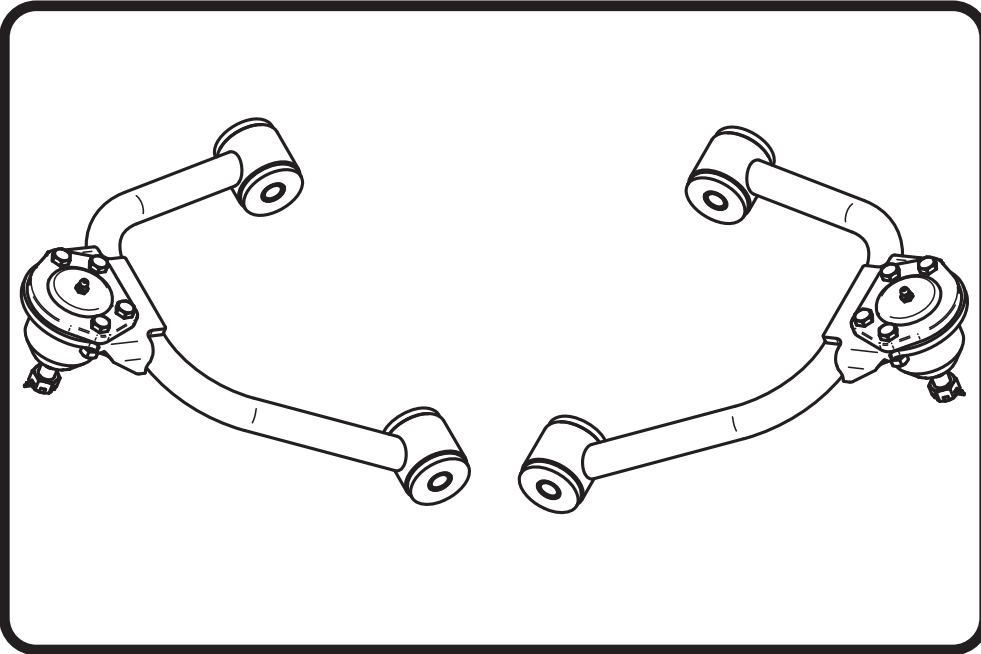

1999-2006 Silverado Upper StrongArms Installation Instructions

Table of contents

Page 10.....	Included components
Page 11.....	Getting Started
Page 12.....	PosiLink Installation





Upper Control Arm ComponentsIn the box

Item #	Part Number	Description	QTY
1	90000630	Upper Control Arms	2
2	90000902	Upper Balljoint - Proforged # 101-10044	2
3	70010759	Delrin Control Arm Bushing	8
4	90001097	Delrin Bushing Inner Sleeve	4
5	90000902 KIT	Upper Balljoint Bolts	8
6	90000902 KIT	Upper Balljoint Hex Nuts	8
7	90000902 KIT	Upper Balljoint Lock Washers	8

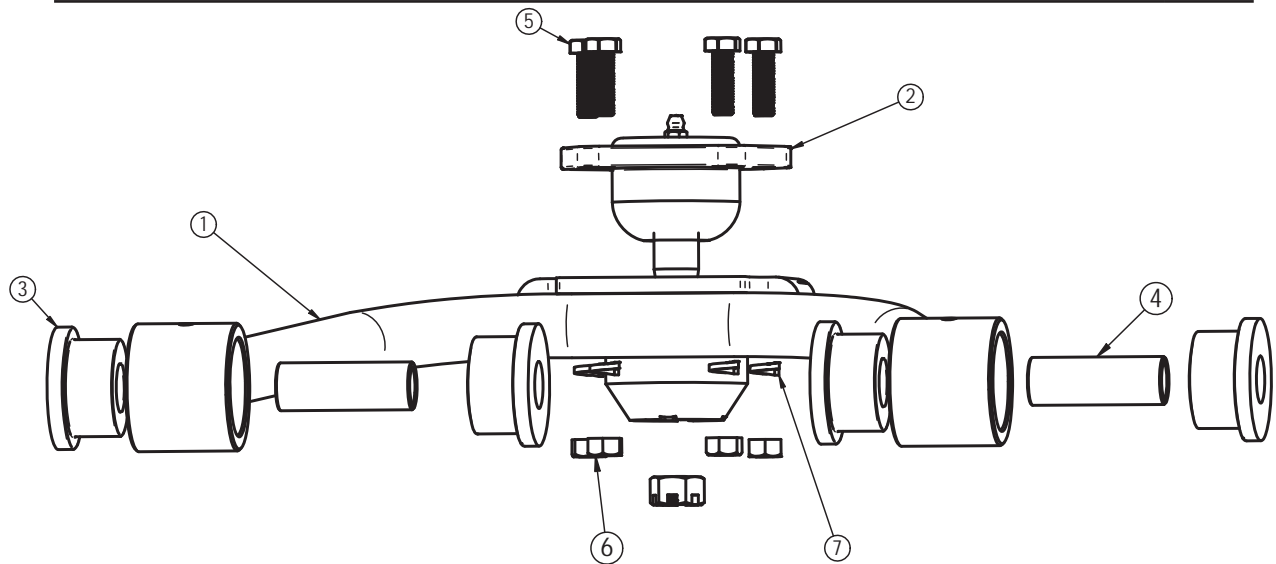

Getting Started.....

2.

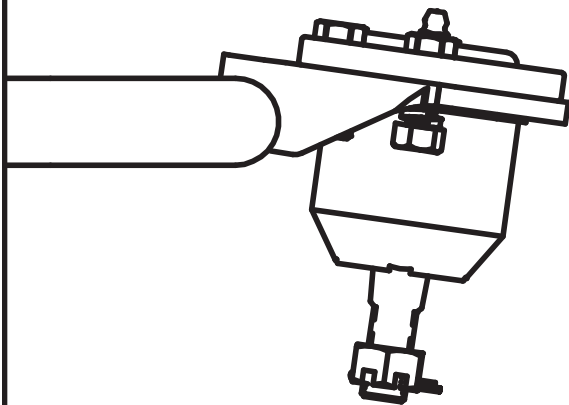

1. Remove the Upper Control Arms. The Camber Bolts need to be reinstalled in the same positions they are removed from. We recommend marking their positions for reassembly. Refer to the factory service manual for disassembly procedure. After removing the factory upper control arm, clean the bushing mounting surfaces on the frame.

2. Insert the Ball Joint into the Control Arm from the TOP side with the Stud pointing downward. Insert the supplied Bolts from the top side. Install a Lock Washer and Hex Nut on the threads of each bolt. Torque the hardware to 20 ftlbs.



Getting Started.....



3. The Driver and Passenger Control Arms are identical. Insert the Control Arm into the OEM frame mount with the balljoint stud pointing down. The Gussets of the Balljoint Plate should also point down.



4. Bolt the arm to the frame using the factory camber bolts. Torque to 140 ft-lbs.

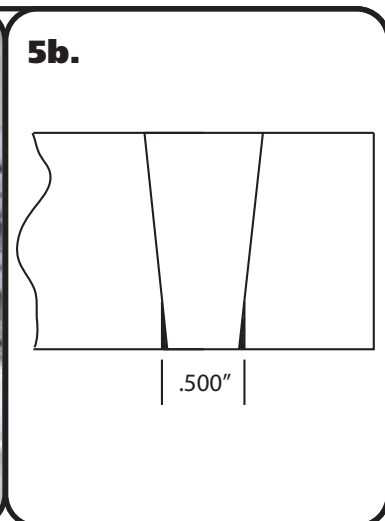

5. Insert the balljoint into the spindle. You will need to clearance the bottom of the taper with a 1/2" Drill bit. Refer to **Images 5a & 5b**. **Image 5b** illustrates the cleared spindle taper. The drawing is exaggerated for illustration purposes.

6. Slide the balljoint pin into the spindle and install the castle nut on each one. Torque the balljoint nuts and install cotter pins in each one.

Balljoint nut Torque Specs:

Torque to 50 ft lbs and then tighten nut to align cotter pin hole not exceeding 90ft lbs.



Part # 11389300 - 1999-2006 Silverado Drop Spindles



Recommended Tools

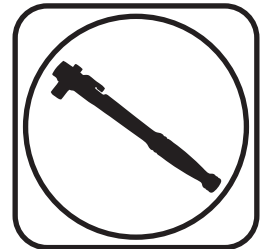

1999-2006 Silverado Drop Spindles Installation Instructions

Installation

Refer to the instructions included with the spindles except;

Balljoint nut Torque Specs:

Upper: Torque to 50 ft lbs and then tighten nut to align cotter pin hole not exceeding 90ft lbs.





Part # 11389100 - 1999-2006 Silverado Front MuscleBar



Recommended Tools



1999-2006 Silverado Front MuscleBar Installation Instructions

Table of contents	
Page 14.....	Included Components and Hardware List
Page 15.....	MuscleBar Installation



Major ComponentsIn the box

Part #	Description	QTY
90001768	Front MuscleBar	1

HARDWARE KIT COMPONENTS #90002759

Description	QTY
Frame Bushing	2
Frame Bushing Strap	2
Lithium Grease	1
End Link Kit (for OEM Arms only)	2
End Link Bushings	8
End Link Spacer	2
End Link Bushing Washers	8
End Link Bolt & Nut Kit	2

Getting Started.....

Remove the OEM Swaybar to prepare for the MuscleBar SwayBar installation.

If using Ridetech StrongArms, the PosiLink Assembly is included with the lower StrongArms.

If you are using the OEM control arms, the end link kit provided with this kit will be used.

1. Use the supplied grease for the poly frame bushings. Apply a thin coat of grease to the inside of the bushings.



2. Open up the Poly SwayBar Bushings and install them over the MuscleBar.



MuscleBar Installation



3. Slide the MuscleBar into position on the truck. The SwayBar Arms will be above the steering linkage. Install Bushing Straps Over the Poly MuscleBar Bushing and bolt them in place using the OEM hardware. Do not tighten the hardware until the PosiLinks are hooked up to the MuscleBar.



STRONGARM LINKAGE

4. Install the T-Bushing on the Straight PosiLink end with the Large OD against the PosiLink. Insert the assembly into the swaybar with the threads pointing up. Install a 7/16" Flat Washer followed by a M12-1.75 Nylok Nut. Torque to 50 ftlbs. Next, tighten the bushing mount hardware to 30 ftlbs.

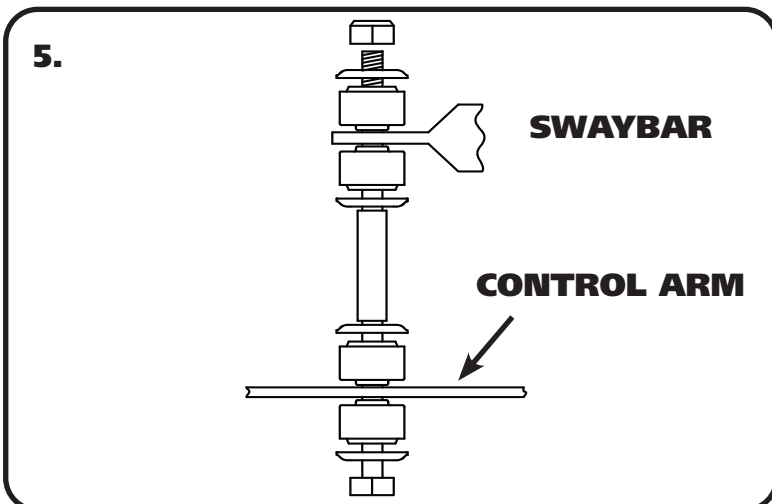

OEM CONTROL ARM LINKAGE

5. Install the End Links. Use Diagram "5" for proper installation. Tighten the Hex Nut enough to slightly compress the Bushings.



Part # 11387199

1999-2006 Silverado Rear Bolt-On 4-Link Suspension System



Recommended Tools

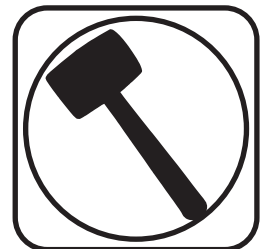
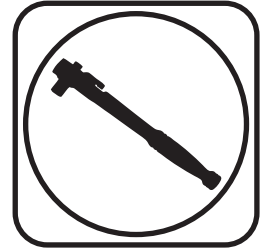

1999-2006 Silverado Rear Suspension Installation Instructions

Table of contents

Page 17-18.....	Included Components
Page 19-20.....	Hardware List & Disassembly
Page 21-25.....	C-Notch Installation
Page 26.....	Axle Mount & Lower Shock Mount Installation
Page 27.....	Installing Lower Bars
Page 28.....	Upper Bar Installation
Page 28-31.....	Panhard Mount Installation
Page 32.....	Panhard Bar Installation
Page 33.....	Shockwave/CoilOvers Installation
Page 34.....	Carrier Bearing Mount
Page 35-36.....	E-Brake Cable Relocation
Page 37.....	Bed Modification & Bumpstop Installation





Major ComponentsIn the box

Item #	Part #	Description	QTY
1	90003234	Driver C-Notch	1
2	90003235	Passenger C-Notch	1
3	90003236	Lower Axle Bracket	2
4	90001411	Upper Axle Mount	2
5	90003237	Panhard Axle Mount	1
6	90003238	Panhard Mount Clamp	1
7	90002804	C-Notch Nut Plate - Driver	1
8	90002805	C-Notch Nut Plate - Passenger	1
9	90001038	Lower Bars - 33.250" center to center	2
10	90003239	Upper Bars - 16.125" center to center	2
11	90003247	Panhard Bar - 35.00" center to center	1
12	90000311	C-Notch Spacer Plate - 1999 & 2000 Trucks	2
13	90000209	Carrier Bearing Spacer - used on carrier bearing equipped trucks	1
14	90000310	Transmission Spacer	1
15	90001318	RH R-Joint Threaded Housing	3
16	70002825	5/8" Shock Stud	2
17	90001624	Aluminum Lower Shock Mount	2
18	90002883	Lower 4 Link Bar Front T-Bushing	4
19	70013334	R-Joint Spacers - Panhard - .625" ID x .620" long	2
20	70013769	R-Joint Spacer - Lower Bars - Front - .625" ID x 1.240" Long	4
21	70013882	R-Joint Spacers - Upper Bars & Lower Rear - .625" ID x .740" long	12
22	70013949	R-Joint Spacers - Panhard Bar - .500" ID x .620" long	2
23	90000461	Panhard Stud	1
24	99752004	3/4"-16 Jam Nut - Installed on Upper Control Arm	3
25	70013322	Short Bumpstops	2
26	99626005	U-Bolt 5/8-18 3.13W x 6.06L, Square Shoulder	4
27	90002067	Lower Shock Bearing Spacers	4
28	70013683	C-Notch Template - Driver - NOT SHOWN	1
29	70013682	C-Notch Template - Passenger - NOT SHOWN	1
R-Joint Components - (Installed in bar ends)			
	70013279	Retaining Ring	7
	70013280	Wavo Wave Spring	7
	70013275	R-Joint Center Ball	7
	70013276	R-Joint Composite Center Ball Cage	7



Major ComponentsIn the box

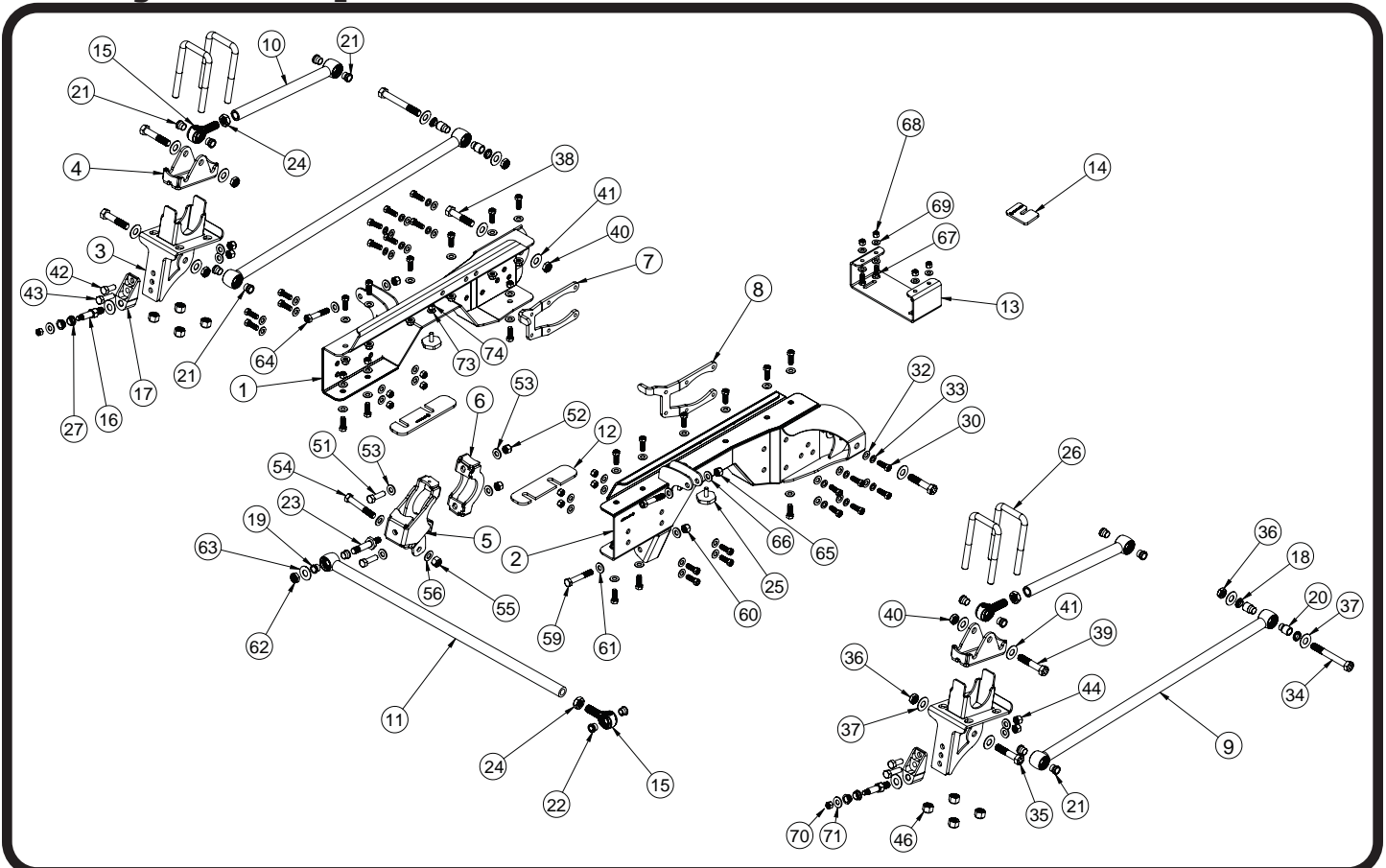

R-JOINT SPACER INSTALLATION

Install the Spacers by inserting the SMALL side of the SPACER into the Center Pivot Ball. Push them in until they bottom out and stop.

LOWER FRONT R-JOINT

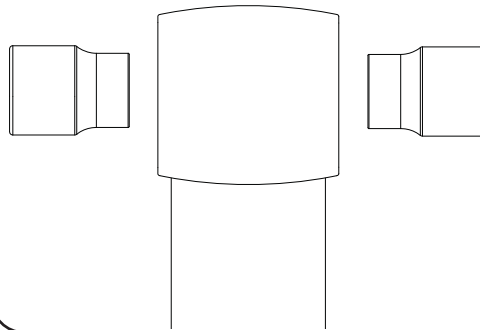

ALL OTHER R-JOINTS

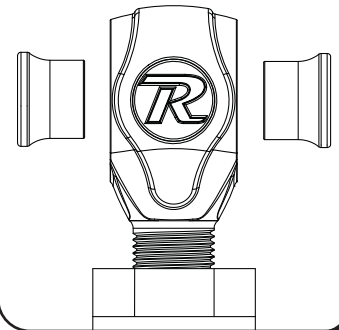

New R-Joints will be quite stiff (75-90 in/lbs breakaway torque) until they "break in" after a few miles of use. After the break in period they will move much more freely. Because the composite bearing race contains self lubricating ingredients, no additional lubrication is needed or desired. Any additional lubrication will only serve to attract more dirt and debris to the R-Joint and actually shorten its life.



Hardware ListIn the box (Kit# 99010160)

The Hardware Kit contains bags to help aid in selecting the correct hardware for the component being installed. The hardware list shows how the hardware is bagged.

Item #	QTY	Part Number	Description	Item #	QTY	Part Number	Description
"C" NOTCH MOUNTING				PANHARD AXLE BRACKET			
30	34	99431021	7/16" x 1 1/4" USS Bolt	51	2	99501046	1/2-13 X 1 3/4 Hex Bolt
30	4	99431032	7/16" x 1 1/4" USS BHCS	52	2	99502009	1/2-13 Nylok Nut
31	26	99432010	7/16" USS Nylok Nut	53	4	99503001	1/2 Flat Washer
32	64	99433005	7/16" SAE Flat Washer	54	1	99561002	9/16-18 X 3 1/2 Hex Bolt
33	16	99433003	7/16" Split Lock Washer	55	1	99562001	9/16-18 Nylok Nut
LOWER 4LINK BARS				56	2	99566003	9/16 Flat Washer
34	2	99621007	5/8" x 5" SAE GR8 Bolt	PANHARD STUD			
35	2	99621004	5/8" x 3" SAE Gr. 8 Bolt	57	1	99562001	9/16-18 Nylok Nut
36	4	99622006	5/8" SAE Nylok Jam Nut	58	1	99566003	9/16 Flat Washer
37	8	99623001	5/8" SAE Flat Washer	PANHARD BAR MOUNTING			
UPPER 4LINK BARS				59	1	99501025	1/2-13 X 3 1/4 Hex Bolt
38	2	99621004	5/8" x 3" SAE Bolt	60	1	99502009	1/2-13 Nylok Nut
39	2	99621018	5/8" x 3 1/4" SAE Bolt	61	2	99503001	1/2 Flat Washer
40	4	99622006	5/8" SAE Nylok Jam Nut	62	1	99622006	5/8-18 Thin Nylok Nut
41	8	99623001	5/8" SAE Flat Washer	63	1	99623001	5/8 Flat Washer
LOWER SHOCK MOUNT				UPPER SHOCK MOUNTING			
42	2	99501019	1/2"-13 x 1 1/4" Hex Bolt	64	2	99501064	1/2" x 2 3/4" USS Bolt
43	2	99501046	1/2"-13 x 1 3/4" Hex Bolt	65	2	99502009	1/2" USS Nylok Nut
44	4	99502001	1/2"-13 Nylok Nut	66	4	99503012	1/2" SAE Flat Washer
45	4	99503001	1/2" SAE Flat Washer	CARRIER BEARING MOUNT			
AXLE BRACKET TO AXLE				67	4	99371003	3/8"-16 X 1" Hex Bolt
46	8	99622013	5/8" SAE High Nut	68	4	99372002	3/8"-16 Nylok Nut
47	8	99623010	5/8" SAE Flat Washer	69	8	99373003	3/8" SAE Flat Washer
BRAKE JUNCTION BLOCK				SHOCK STUD			
48	1	99311013	5/16-24 X 1 Hex Bolt	70	2	99432002	7/16"-20 Nylok Nut
49	1	99313002	5/16 Flat Washer	71	2	99432002	7/16" SAE Flat Washer
50	1	99313003	5/16 Split Lock Washer	72	4	99623004	5/8" SAE Flat Washer
				BUMP STOPS			
				73	2	99373003	3/8" SAE Flat Washer
				74	2	99372002	3/8"-16 Nylok Nut

Disassembly

Congratulations on your purchase of the Ridetech Rear 4 Link System. This system has been designed to give your truck excellent handling along with a lifetime of enjoyment. Some of the key features of this system: C-notches to give your suspension the travel it needs at the lowered height, 4Link setup to replace the leaf spring and provide better control of the rear axle, and the biggest feature of all, it allows the use of Shockwaves or CoilOvers.



Disassembly

Note: This system is designed for use with the Ridetech Shockwaves or CoilOvers. **The factory shocks and springs or the factory sway bar will not fit this 4Link.**

1. Raise the vehicle to a safe and comfortable working height and support it by the frame. You will need to be able to move the rear differential up and down. Use a jack under the rear axle so it can be raised and lowered as needed during the install.
2. **Remove the bed, retaining the hardware for reassembly. This kit can NOT be installed with the bed on. The bed requires minor modifications before reinstalling it.**
3. Remove the leaf springs and shock absorbers. Refer to the factory service manual for proper disassembly procedures.



4. The brake line bracket will need to be removed from the top of the driver side frame rail. This will be reattached later.



5. Unbolt the emergency brake cable bracket from the driver side frame rail. It is located between the axle and the front leaf spring hanger. Retain the hardware for reassembly.



"C" Notch Installation



6. To allow maximum drop on this truck, the frame must be notched. The template for the notch will locate off of the 2 large oval holes. Use the supplied "C" Notch template to mark out the frame for cutting. Before cutting out the frame, support the frame in front of and behind the "C" Notch area. We suggest doing one side at a time. The tall end of the template is located to the front of the truck.

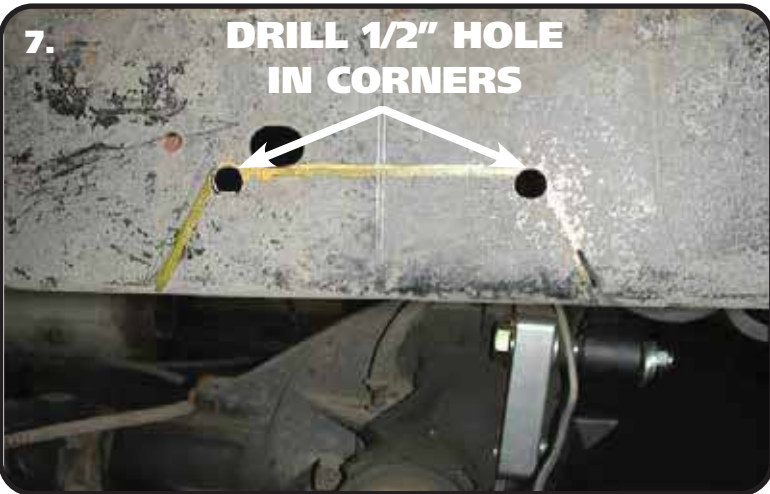

7. Use the supplied Template to mark the cut lines on the frame, then drill out the two corners with a 1/2" drill bit. This will give the cut a round edge and eliminate the possibility for stress fractures. Then cut the notch with a saw-z-all, cutoff wheel, or plasma cutter. Grind all edges smooth. Check the inside of the frame for wires or lines before drilling or cutting.



99 ONLY!!!

8. We have come across some frames that have a protrusion stamped in the frame above the axle. This will need to be flattened out to get the c-notch fitting tightly. We did this by extending the horizontal cut forward to the end of the protrusion then cutting straight down to the bottom of the frame. After the frame is cut, use a hammer or vise grips to bend the protrusion flat. Refer to **Image 8**.



"C" Notch Installation

9.



9. After cutting, slip the c-notch over the frame to check the fitment.

10.



10. The front edge of the c-notch should be 4 1/2" from the oval hole in front of it. Trim the opening to move the c-notch forward or backward to achieve 4 1/2".

11.



11. Use a 7/16" Drill bit to drill the holes in the side of the frame. DO NOT DRILL THE HOLES WHERE THE EMERGENCY BRAKE CABLE BRACKET IS BOLTED, OR THE TOP AND BOTTOM OF THE C-NOTCH. There are 10 holes in the side that need to be drilled.



"C" Notch Installation



12. After drilling the holes in the side of the frame, remove the C-notch to insert the front nut plate. **Image 12** shows the Driver Nut Plate. The top tab is bent to the inside of the frame to allow it to be held in place. After inserting the nut plate, reinstall the C-notch. Install a 7/16" Lock Washer, & 7/16" Flat Washer on (6) 7/16" x 1 1/4" Bolts. Hold the nut plate in place and insert the bolts/washer through the c-notch and frame threading them into the nut plate. Repeat on the other side. **LEAVE THE HARDWARE LOOSE.**

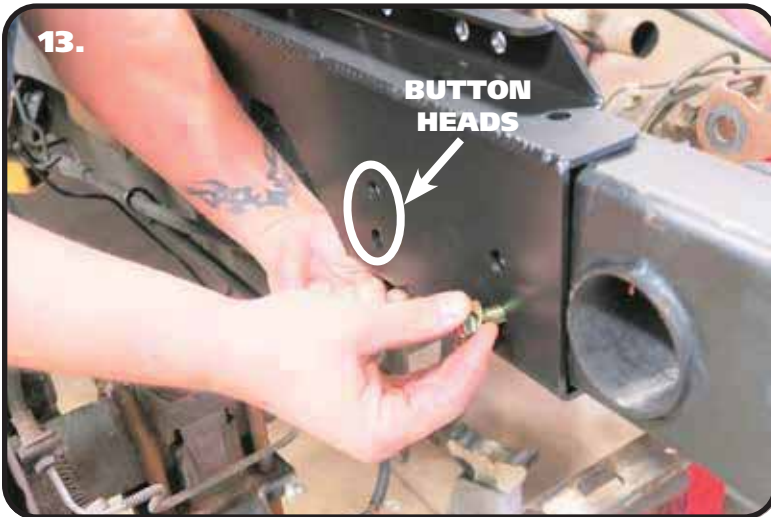

13. Install a 7/16" lock washer, & 7/16" flat washer on (2) 7/16" x 1 1/4" Bolts & **(2) 7/16" x 1 1/4" BUTTON HEAD CAP SCREWS.** This hardware gets installed in the rear section of the c-notch. **THE 7/16" BUTTON HEADS NEED TO BE INSTALL IN THE 2 FRONT HOLES CIRCLED IN IMAGE 13.** The 2 regular 7/16" bolts will be installed in the rear holes. Install a 7/16" flat washer and 7/16" nylok nut on each bolt sticking through the frame. Repeat on the other side.

Repeat Steps 6-13 on the other side.



14. Tighten all of the c-notch side bolts. Torque to 50 ftlbs.



"C" Notch Installation



15. Reinstall the emergency brake cable bracket using the OEM hardware.



16. Use a 7/16" drill bit to drill the remaining holes in the top and bottom of the frame. Install a 7/16" Flat Washer on the remaining 7/16" x 1 1/4" Bolts. Insert bolt/washers in the drilled holes of the c-notch. Install a 7/16" Flat washer and 7/16" Nylok Nut on the threads sticking through the c-notch/frame. **DO NOT TIGHTEN.**



17. Use a 7/16" drill bit to drill out the rear hole of the OEM brake line bracket.



"C" Notch & Axle Mount Installation



18. Remove the nut and washer from the 2nd from rear top bolt of the driver side c-notch. Install the brake line bracket on the bolt and reinstall the nut and washer. If your truck is 2001 and newer, tighten the top and bottom c-notch hardware to 50 ftlbs then skip to step 20. If you have a 1999 - 2000, proceed to step 19.



1999-2000 ONLY

19. The 1999 & 2000 model year trucks have a slightly shorter frame rail height than the newer trucks. The kit includes (2) spacers to fill the gap that is on the bottom rear of the c-notch. Insert a spacer in the gap of the driver and passenger side c-notches. Tighten the top and bottom hardware to 50 ftlbs.



20. Sit the upper bar mount on the leaf spring pad of the axle. The locating pin needs to insert into the leaf spring locating hole of the leaf spring pad.



Axle Mount & Lower Shock Mount Installation



21. The axle mounts are the same for driver and passenger sides. Install a supplied 5/8" u-bolt in each side of the upper bar mount. The u-bolts will nest in the slots of the upper mount. Slide an axle mount on the U-bolts with the top tabs inserted into the leaf spring pad.



22. Hold the mount in place and install a 5/8" flat washer and 5/8" high nut on the threads of the u-bolts sticking through the axle mount. Tighten the nuts evenly in a criss-cross fashion making sure the tabs of the axle mount are touching the leaf spring pad evenly. Torque the nuts in a criss-cross fashion to 60 ftlbs. Repeat on the other side.



23. The lower shock mount attaches with (1) 1/2"-13 x 1 1/4" hex bolt, (1) 1/3"-13 x 1 3/4" hex bolt, & (2) 1/2" flat washer, & (2) 1/2"-13 nylok nuts. The lower mount gets attached to the 2nd and 3rd hole up from the bottom of the axle mount. When the shock mount is installed correctly, the bottom of the lower shock mount is 1/8" above the bottom of the axle mount. Insert the bolts through the aluminum shock mount with the 1 1/4" long bolt in the top hole, 1 3/4" in the bottom hole. Insert the bolts through the axle mount and install the flat washers & nylok nuts on the threads sticking through. Repeat on both sides and torque the bolts/nuts to 75 ftlbs. Install a 5/8" flat washer onto the 5/8"-18 threads of the shock stud. Apply Red Loctite to the 5/8" threads of the stud. Thread the shock stud into the threaded hole of the lower mount. Repeat on both sides and torque the shock stud to 65-75 ftlbs.



Installing Lower Bars



24. Insert (2) .625" ID x .740" long R-Joint spacers into the R-Joint of one end of each lower bar. The small diameter of the spacer goes into the R-joint. Insert the rear of the lower bar R-Joint into the lower axle bracket. Line the through hole of the R-Joint with the of holes of the axle bracket. Install a 5/8" flat washer on to a 5/8"-18 x 3" hex bolt, insert into the lined up holes. Install a 5/8" flat washer followed by a 5/8"-18 THIN nylok nut. Repeat on both sides and tighten the bolts/nuts enough to eliminate any gaps.



25. The kit includes (4) t-busings for the front leaf spring mount. Insert a t-bushing in each front leaf spring mounting hole with the small OD inserted into the hole. The large OD needs to be on the outside of the brackets.



26. Insert the .625" ID x 1.240" long R-Joint spacers into the front of the lower bar (33.250") with the small OD inserted into the R-joint. The small diameter of the spacer goes into the R-joint. Insert the front lower bar R-Joint into the front leaf spring mount. Line the through hole of the R-Joint with the of holes of the leaf spring mount. Install a 5/8" flat washer on to a 5/8"-18 x 5" hex bolt, insert into the lined up holes. Install a 5/8" flat washer followed by a 5/8"-18 THIN nylok nut. Repeat on both sides and tighten the bolts/nuts enough to eliminate any gaps.



Upper Bars & Panhard Mount Installation



27. Insert (2) .625" ID x .740" long R-Joint spacers into the R-Joint of one end of each upper bar (16.125"). The small diameter of the spacer goes into the R-joint. Insert the front upper bar R-Joint into the upper bar mount built into the c-notch. Line the through hole of the R-Joint with the of holes of the bar mount. Install a 5/8" flat washer on to a 5/8"-18 x 3" Hex bolt, insert into the lined up holes. Install a 5/8" flat washer followed by a 5/8"-18 THIN nylok nut. Repeat on both sides and tighten the bolts/nuts enough to eliminate any gaps.



28. Insert (2) .625" ID x .740" long R-Joint spacers into the rear R-Joint of each upper bar. The small diameter of the spacer goes into the R-joint. Insert the rear upper bar R-Joint into the upper axle bracket. Line the through hole of the R-Joint with the of holes of the axle bracket. Install a 5/8" flat washer on to a 5/8"-18 x 3 1/4" hex bolt, insert into the lined up holes. Install a 5/8" flat washer followed by a 5/8"-18 THIN nylok nut. Repeat on both sides and tighten the bolts/nuts enough to eliminate any gaps.



29. Depending on the year of your truck, it may have the rear brake hose attached to the axle above the driver side shock mount. If your truck doesn't have the brake line mounted in this location, skip to **Step 33**. If your truck has the brake line mounted in this location, continue to **Step 30**.



Panhard Mount Installation



30. Remove the bolt that attaches the brake hose to the bracket. This will allow you to move the brake line out of the way to cut the bracket off the axle tube.



31. We used a die-grinder with a cutoff wheel to cut the brake line bracket off the axle tube. Be careful to not cut into the axle tube.



32. With both sides of the bracket cut, remove it from the axle tube. Grind the area smooth.



Panhard Mount Installation



33. Unbolt the emergency brake cable clamp from the outside of the driver shock bracket. We will cover reattaching it later in the instructions.



34. Position the panhard mount in the driver side shock bracket. The bottom mounting hole of the panhard bracket will align with the factory shock mounting hole.



35. Install a 9/16" SAE flat washer on a 9/16"-18 x 3 1/2" bolt. Insert the bolt through the OEM lower shock mount and panhard bar bracket. Install a 9/16" flat washer and 9/16"-18 nylok nut on the threads of the bolt. Do not tighten the hardware at this time.



Panhard Mount Installation



36. Position the panhard mount axle clamp on the front side of the axle tube, aligning it with the panhard mount that is already in position.



37. Install a 1/2" SAE flat washer on each of (2) 1/2"-13 x 1 3/4" bolts. Insert the bolt/washers in the top and bottom mounting holes of the clamp/mount. Install a 1/2" SAE flat washer and 1/2"-13 nylok nut on the threads of each bolt. Torque these bolts to 75 ftlbs. You can now torque the 9/16" hardware that was installed previously. Torque the 9/16" hardware to 110 ftlbs.



38. If your truck required the brake line bracket to be cutoff the axle tube, reattach it to the top of the panhard mount. Use the 5/16"-24 x 1" bolt, 5/16" split lock washer, & 5/16" SAE flat washer that's supplied in the kit.



Panhard Bar Installation



39. Insert the short side of the panhard stud into the rear hole of the panhard axle mount. Install a 9/16" SAE flat washer and 9/16"-18 nylok nut on the threads that are sticking through the bracket. Torque to 95 ftlbs.



40. Insert (2) .500" ID x .620" long R-Joint spacers into the R-Joint of one end of the panhard bar (35.00"). The small diameter of the spacer goes into the R-joint. Insert the panhard bar R-Joint into the panhard mount that is on the passenger c-notch. Line the through hole of the R-Joint with the of bottom holes of the panhard bracket. Install a 1/2" flat washer on to a 1/2"-13 x 3 1/4" hex bolt, insert into the lined up holes. Install a 1/2" flat washer followed by a 1/2"-13 nylok nut. Tighten the bolts/nuts enough to eliminate any gaps.

NOTE: The panhard mount has 2 sets of mounting holes to help set the panhard bar as level as possible depending on your ride height. We start out in the bottom hole.



41. Install a .625" ID x .740" long R-joint spacer into each side of the R-joint of the axle end of the panhard bar. The small diameter of the spacer goes into the R-joint. Slide the R-joint onto the stud and fasten in place with a 5/8" flat washer and 5/8"-18 THIN nylok nut. Torque to 95 ftlbs.



Shockwave/Coilover Installation



42. Insert the 1/2" ID Shock Bearing Spacers into the Bearing of the ShockWave/CoilOver. Install a 1/2" Flat Washer on a 1/2"-13 x 2 3/4" Bolts. Insert the top of the shock into the shock mount on the c-notch with the adjusting knob to the outside. Line up the holes and insert the bolt/washer. Install a 1/2" Flat Washer and 1/2"-13 Nylok Nut on the threads and tighten to 50 ftlbs.



43. The Shock Stud requires spacers that are .400" long (90002067). Install a 5/8" ID 90002067 spacer (**Small side towards shock body**) onto the lower Shock Stud. Slide the bottom of the Shock onto the Stud. Install a second 5/8" ID 90002067 Spacer onto the Stud (**small side towards shock**). You may need to jack the rear end up to Slide the Shock onto the Stud.



44. Install the 7/16" Flat washer and 7/16" Nylok nut. Tighten the upper and lower shock bolts. Torque the Upper Bolt to 50 ftlbs and the Lower Nut to 40 ftlbs. The designed ride height of the CoilOver/Shockwave is 14 1/2" center to center.



Carrier Bearing Mount



45.

TRUCKS WITH CARRIER BEARINGS ONLY! IF YOUR TRUCK DOESN'T HAVE A CARRIER BEARING, SKIP TO STEP 48

35. The driveshaft carrier bearing will need to be relocated to optimize driveline angles at your new lower ride height. Refer to steps 35-37 for carrier bearing mount installation. Unbolt the carrier bearing retaining the OEM hardware. Center the new mount on the OEM mount. Use the OEM slots as a reference. Mark the holes and the inner edge of the mount.

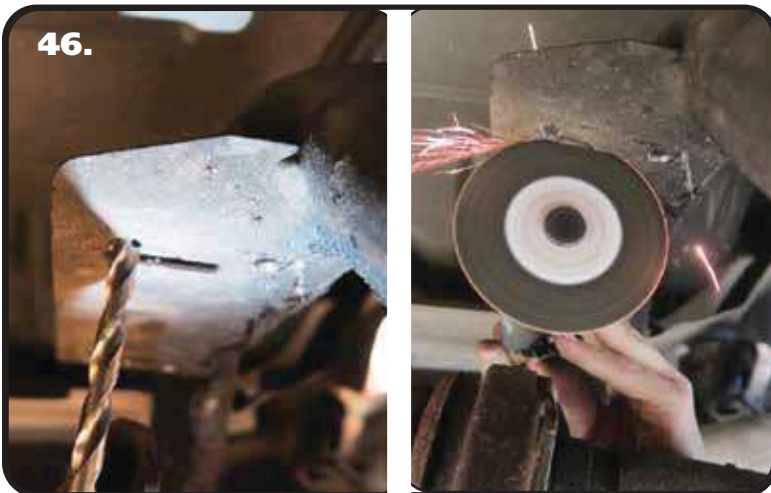

46.

46. Image 46 illustrates drilling and cutting the OEM carrier bearing mount. Drill the (4) marked holes using a 3/8" drill bit. Cut along the line that was marked along the inner edge of the new mount. This will remove the center of the OEM mount.



47.

47. The new carrier bearing bracket is then bolted onto the remaining tabs. Attach the bracket using 3/8"-16 x 1" Bolts, Flat Washers, & 3/8"-16 Nylok Nuts. The carrier bearing mount is rotated 180 degrees and attached to the supplied bracket with the OEM hardware as shown in the picture in **Image 47**. The kit includes a Transmission Spacer that will need to be used in conjunction with the carrier bearing mount. Install it by loosening the hardware that attaches the transmission mount to the transmission crossmember. Jack up the rear of the transmission just enough to slide the spacer in and tighten the hardware.



Emergency Brake Cable Relocation



48. Steps 48-52 cover the emergency brake cable relocation. The cables need to be relocated to gain Shockwave/CoilOver clearance. Start by removing the bolt that clamps the passenger side cable to the driver side axle tube. Spread out the clamp to remove it from the cable. Retain the clamp, it will be reinstalled.



49. Disconnect the top cable from the cable yoke. This can be done by twisting the top of the yoke to the rear enough to get the cable out.



50. Disengage the cable from the frame mount and pull it out. The cable runs over the top of the axle from the factory, it needs to be pulled out and rerouted under the axle. Reroute the cable under the axle and reinsert in into the frame mount and connect to the yoke.



Emergency Brake Cable Relocation & Bed Modification



51. Reinstall the removed clamp with the ears pointing upward. Install the clamp on the cable and close it with a pair of pliers. Reattach the clamp to the OEM mount using the OEM hardware.



52. The Driver side emergency brake cable only requires the clamp be moved on the cable. Remove the attaching bolt and spread out the clamp enough to allow it to be moved. Move the clamp from the metal area to the rear edge of the plastic sheath. The rear edge of the clamp will line up with the rear edge of the sheath. Use the OEM bolt to reattach it.



53. The passenger emergency brake cable will get attached to the rear bolt of the passenger c-notch. Use the OEM clamp that attached it to the axle housing.



Bed Modification & Bumpstop Installation

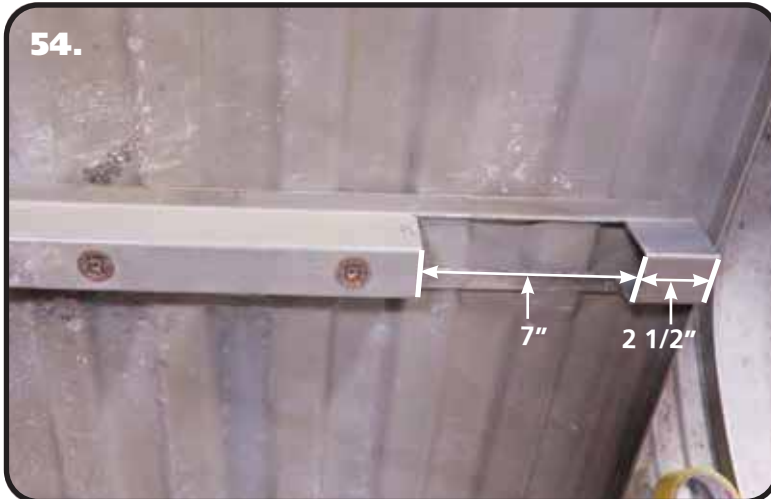

54. Trimming of the bed brace that is in between the wheel wells is necessary to clear the c-notches and wishbone. We cut ours with a die-grinder. **Image 54** shows the passenger side, the dimensions are the same for both driver and passenger. The first notch starts 2 1/2" from the end of the brace. The notch is 7" long. Trim the driver and passenger side using these dimensions. **Image 55** shows the driver and passenger sides cut out.



55. Your bed brace should look like **Image 55** after cutting.



56. Install the Bumpstops into the C-Notch above the axle using the 3/8" Flat Washer and 3/8"-16 Nylok Nut supplied. A bumpstop will need to be installed in each c-notch.

57. Reinstall the bed.

58. Verify all hardware is tight.

59. Set ride height on the truck. The ride height of the Shockwave/CoilOver is approximately 14 1/2". If you are using Shockwaves, this is done by changing the air pressure in the Shockwaves. If you are using CoilOvers, the ride height is done by using the adjuster nut for the coil spring. The coil spring on the CoilOver will have some preload in the spring to get ride height, this is normal.



Part # 21150801 - 5.2" Stroke HQ Series Shockwave

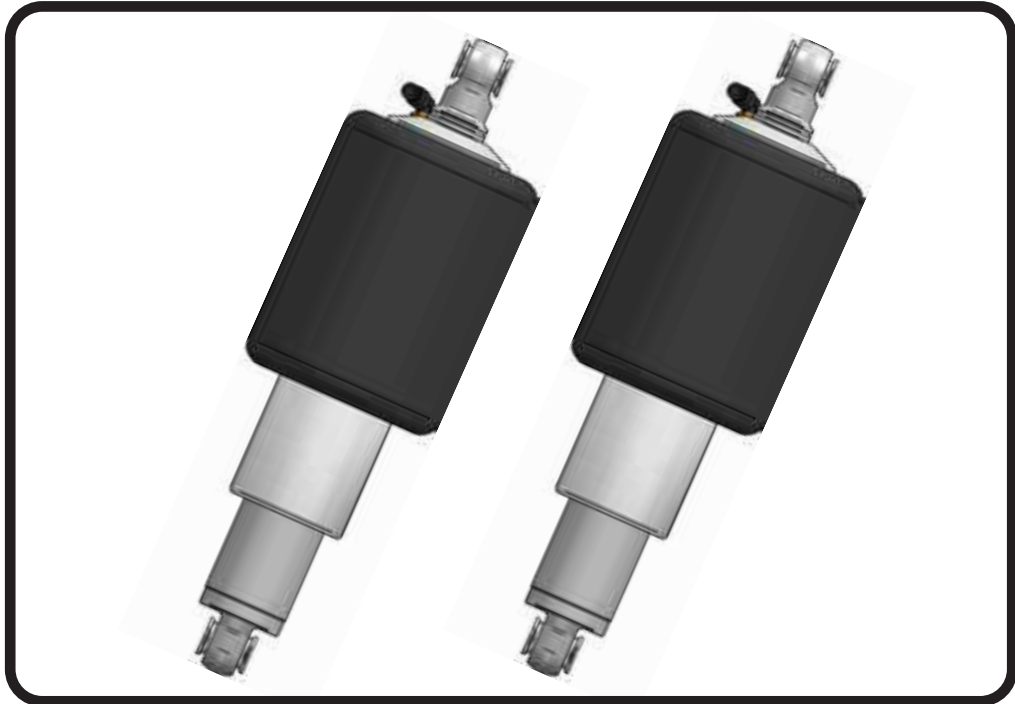

Recommended Tools

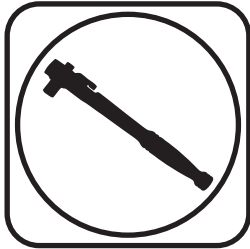

8000 Series Bellow, Eye/Eye 5.2" Shock Installation Instructions

Table of contents

Page 39..... Included components

Page 40..... Notes and Care of Your Shockwave

Page 41..... Shock Adjustment

ShockWave Dimensions:

Center of bearing to Center of bearing:	
Compressed:	11.85"
Ride Height:	14.60"
Extended:	16.42"



Major ComponentsIn the box

Item #	Part #	Description	QTY
1	982-10-805	5.2" Stroke HQ Series Shock	2
2	815-05-022-KIT	1.7" Shock Eyelet	2
3	24090899	8000 Series, 5" Diameter AirSpring	2
4	234-00-153	AirSpring Locking Ring (Installed on Shock)	2
5	90002044	Spacer kit - 1/2" ID and 5/8" ID	4
	90001994	5/8" ID Bearing (installed in shock and eyelet)	4
	90001995	Bearing Snap Ring (installed in shock and eyelet)	8

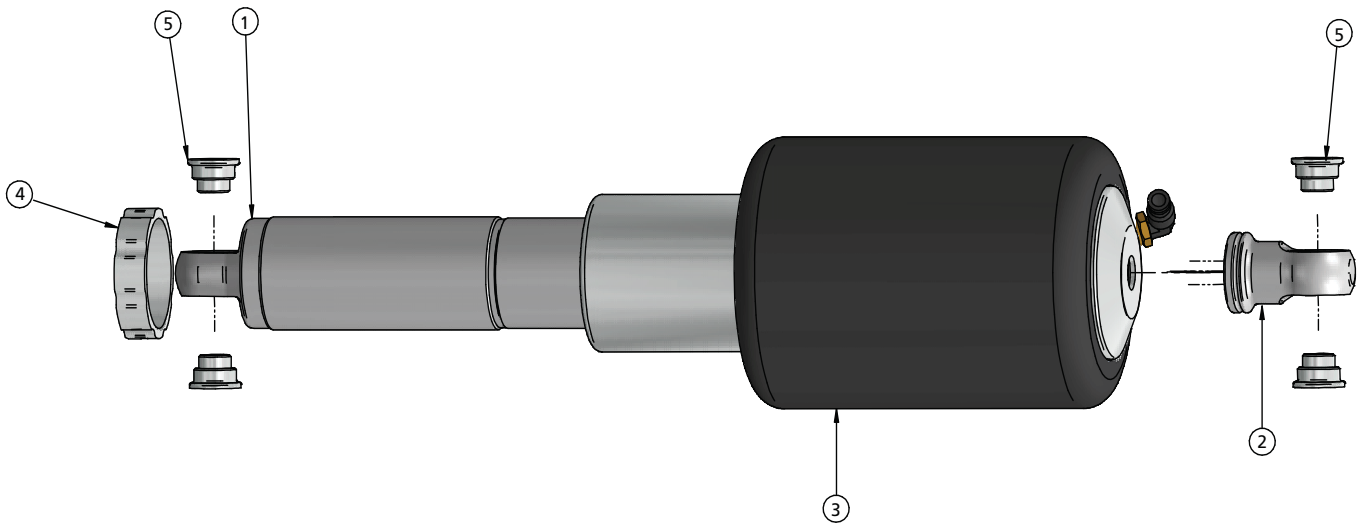

WARNING: ATTEMPTING TO REMOVE THE AIR FITTING WILL DAMAGE IT AND VOID THE WARRANTY.



Notes and Care of your Shockwaves

NOTES:

WARNING: ATTEMPTING TO REMOVE THE AIR FITTING WILL DAMAGE IT AND VOID THE WARRANTY.

You can clock the airfitting location on the ShockWave by turning the AirSpring assembly of the shock. Make sure the fitting doesn't contact the frame.

When cutting the airline, use a razor blade. The cut needs to be a clean cut and square for the airline to seal properly.

The Locking ring on the shock is NOT adjustable. These rings are set at the factory to optimize the AirSpring stroke with the shock stroke.

The care and feeding of your new ShockWaves

1. Although the ShockWave has an internal bumpstop, **DO NOT DRIVE THE VEHICLE DEFLATED RESTING ON THIS BUMPSTOP. DAMAGE WILL RESULT.** The internal bumpstop will be damaged, the shock bushings will be damaged, and the vehicle shock mounting points may be damaged to the point of failure. This is a non warrantable situation.
2. Do not drive the vehicle overinflated or "topped out". Over a period of time the shock valving will be damaged, possibly to the point of failure. This is a non warrantable situation! If you need to raise your vehicle higher than the ShockWave allows, you will need a longer unit.
3. The ShockWave is designed to give a great ride quality and to raise and lower the vehicle. **IT IS NOT MADE TO HOP OR JUMP!** If you want to hop or jump, hydraulics are a better choice. This abuse will result in bent piston rods, broken shock mounts, and destroyed bushings. This is a non warrantable situation.
4. Do not let the ShockWave bellows rub on anything. Failure will result. This is a non warrantable situation.
5. The ShockWave product has been field tested on numerous vehicles as well as subjected to many different stress tests to ensure that there are no leakage or durability problems. Failures have been nearly nonexistent unless abused as described above. If the Shockwave units are installed properly and are not abused, they will last many, many years. ShockWave units that are returned with broken mounts, bent piston rods, destroyed bumpstops or bushings, or abrasions on the bellows will not be warrantied.



Shock Adjustment

Shock Adjustment 101- Single Adjustable

Rebound Adjustment:

How to adjust your new shocks.

The rebound adjustment knob is located on the top of the shock absorber protruding from the eyelet.

You must first begin at the ZERO setting, then set the shock to a medium setting of 12.



-Begin with the shocks adjusted to the ZERO rebound position (full stiff). Do this by rotating the rebound adjuster knob clockwise until it stops.

-Now turn the rebound adjuster knob counter clock wise 12 clicks. This sets the shock at 12. (settings 21-24 are typically too soft for street use).

Take the vehicle for a test drive.



-if you are satisfied with the ride quality, do not do anything, you are set!

-if the ride quality is too soft increase the damping effect by rotating the rebound knob clock wise 3 clicks.

Take the vehicle for another test drive.



-if the vehicle is too soft increase the damping effect by rotating the rebound knob clock wise 3 additional clicks.

-If the vehicle is too stiff rotate the rebound adjustment knob counter clock wise 2 clicks and you are set!

Take the vehicle for another test drive and repeat the above steps until the ride quality is satisfactory.

Note:

One end of the vehicle will likely reach the desired setting before the other end. If this happens stop adjusting the satisfied end and keep adjusting the unsatisfied end until the overall ride quality is satisfactory.