

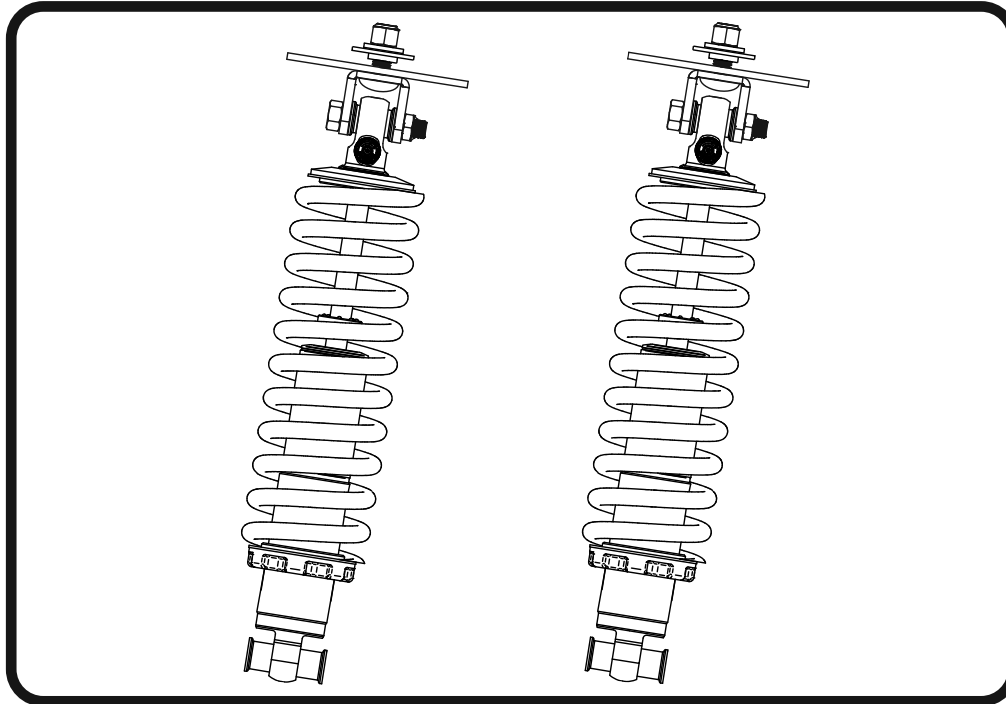

**Part # 11383510** - 99-06 Silverado Front HQ Series CoilOvers



Recommended Tools



## 1999-2006 Silverado HQ Series Front CoilOvers Installation Instructions

### Table of contents

Page 2..... Included Components

Page 3..... CoilOver Installation

Page 4-5..... Final Adjusting and Preloading the Spring

### CoilOver Dimensions:

Center of bearing to Center of bearing:

Compressed: 10.13"

Ride Height: 12.50"

Extended: 14.23"





### Major Components .....In the box

Item #	Part #	Description	QTY
1	982-10-804	4.1" Stroke HQ Series Shock	2
2	815-05-022-KIT	1.7" Upper Shock Eyelet	2
3	59100800	CoilSpring 10" 800lb	2
4	70010828	Delrin Spring Washer	2
5	803-00-109(kit)	Lower Spring Adjuster Nut (803-00-199 kit)	2
6	803-00-199(kit)	Adjuster Nut Locking Screw (803-00-199 kit)	2
7	803-00-199(kit)	Upper CoilSpring Retaining Plate (803-00-199 kit)	2
8	803-00-199(kit)	CoilSpring Plate Retaining Ring (803-00-199 kit)	2
9	90000097	Upper Mounting Plate	2
10	90002043	Upper Shock Bearing Spacers	4
11	90002062	Lower Bearing Spacers (INCLUDED WITH STROGARMS)	4
12	90000359	Upper Shock Mount T-Bushing	2
13	99501018	1/2"-13 x 1 1/2" Carriage Bolt	2
14	99501010	1/2"-20 x 2 1/4" Hex Bolt	2
15	99502003	1/2"-20 Thin Nylok Nut	2
16	99502001	1/2"-13 Nylok Nut	2
17	99503001	1/2" Flat Washer	4
	90001994	5/8" ID Bearing (installed in shock body & eyelet)	4
	90001995	Bearing Snap Ring (installed in shock & eyelet body)	8

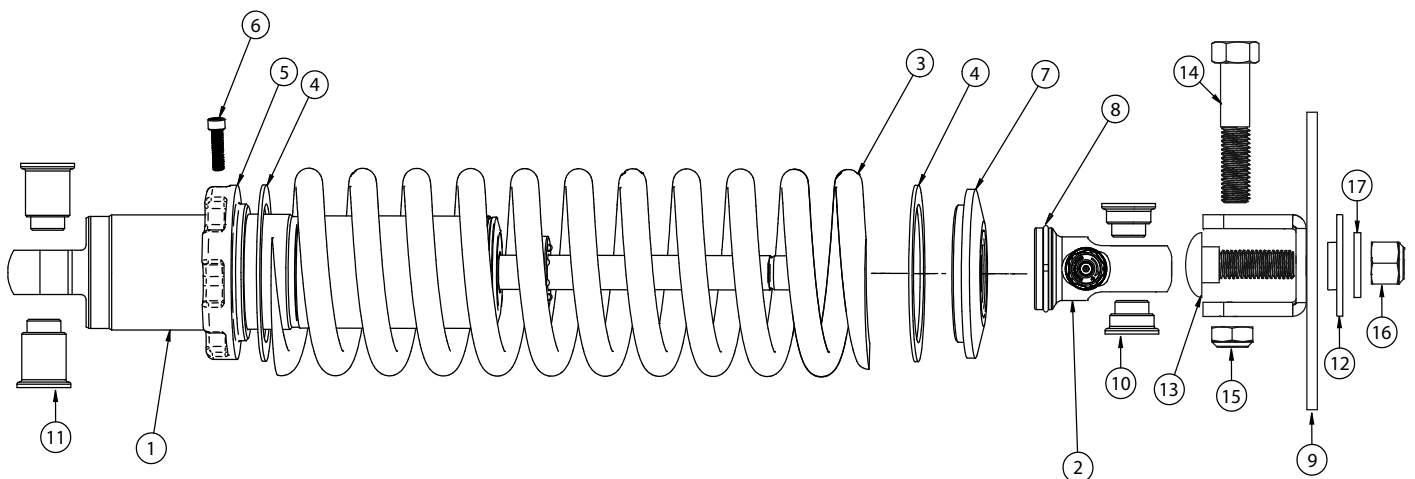



### CoilOver Installation

4.



5.

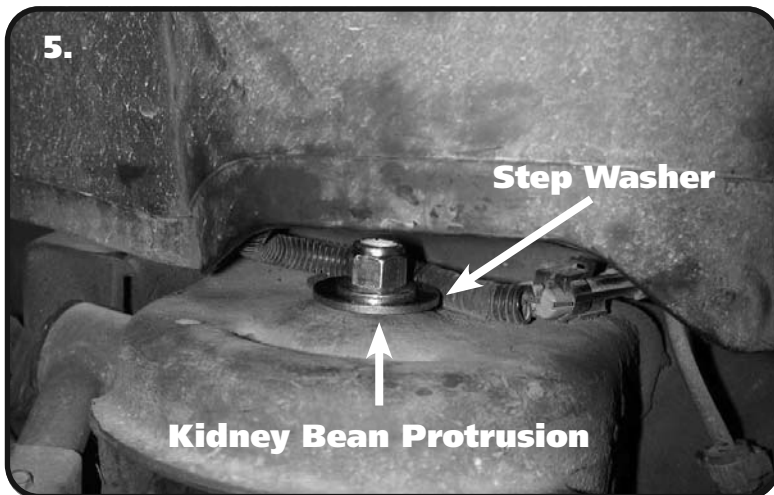

6.

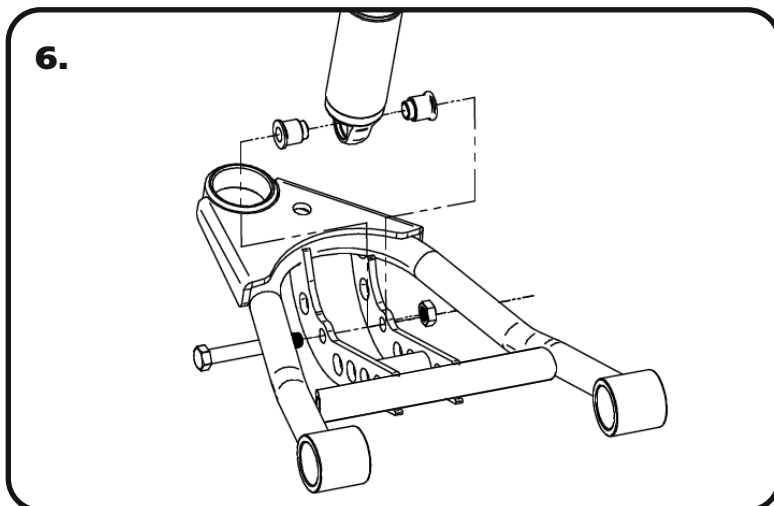

1. Raise and support truck at a safe, comfortable working height. Let the front suspension hang freely.

2. Remove the coil spring, shock absorber, bump stop, upper control arm, and lower control arm. Refer to factory service manual for proper disassembly procedure.

3. Install the CoilSpring on the CoilOver per the instructions on Page 4.

4. Insert the carriage bolt through the square hole in the upper mount. Insert a NARROW Bearing Spacer into each side of the Upper Eyelet. Slide the Eyelet of the CoilOver with the Spacers installed into the Upper Mount. Bolt the top of the CoilOver to the upper mount using a 1/2" x 2 1/4" bolt and Nylok jam nut.

5. Raise the CoilOver up to the coil spring mount with the carriage bolt sticking through the factory shock hole. The hole in the frame is larger than the bolt, so a step washer is supplied. This should be installed on top of the frame, followed by a 1/2" Nylok nut.

**Note:** The kidney bean shaped cutout in the upper bracket will match a protrusion in the coil spring pocket. This will clock the CoilOver so that when the suspension moves the bearing will rotate on the bolt. **If this is not installed properly it will damage the CoilOver.**

6. Raise the lower arm up to the CoilOver and bolt them together using the 1/2" x 3 1/4" bolt and Nylok supplied w/ the lower arms. An aluminum spacer will be on each side of the bearing. Torque to 75 ftbs.

## CoilOver Assembly...



1

First, using the supplied lower adjuster nut (803-00-199) thread the nut onto the shock from the bottom side as seen in figure 1. Remove the plastic pellet that is in the split of the adjuster nut.



4

Once the knob is removed slide a Delrin washer over the eyelet. Next, slide the upper spring mount (803-00-199) over eyelet as seen in figure 4.



2

Next, install a delrin washer then coil spring over the top of the shock as seen in figure 2.



5

Install upper spring mount retainer clip (803-00-199) into the groove on the upper eyelet as seen in figure 5. Then, reinstall adjuster to complete assembly.



3

Before the upper spring mount can be installed screw the adjuster knob on the upper eye mount to the firmest setting (clockwise) as seen in figure 3. Then remove the Knob by holding it while removing the center screw.

**Install the locking screw in the adjuster nut before setting spring preload, but DO NOT tighten until the spring preload has been set.**

**NOTE:** Remember to adjust the shock valving before driving, the shock is currently set to full stiff.

## Shock Adjustment 101- Single Adjustable

### Rebound Adjustment:

How to adjust your new shocks.

The rebound adjustment knob is located on the top of the shock absorber protruding from the eyelet.

You must first begin at the ZERO setting, then set the shock to a medium setting of 12.



-Begin with the shocks adjusted to the ZERO rebound position (full stiff). Do this by rotating the rebound adjuster knob clockwise until it stops.



-Now turn the rebound adjuster knob counter clock wise 12 clicks. This sets the shock at 12. (settings 21-24 are typically too soft for street use).

Take the vehicle for a test drive.



-if you are satisfied with the ride quality, do not do anything, you are set!

-if the ride quality is too soft increase the damping effect by rotating the rebound knob clock wise 3 clicks.

Take the vehicle for another test drive.



-if the vehicle is too soft increase the damping effect by rotating the rebound knob clock wise 3 additional clicks.

-If the vehicle is too stiff rotate the rebound adjustment knob counter clock wise 2 clicks and you are set!

Take the vehicle for another test drive and repeat the above steps until the ride quality is satisfactory.

### Note:

**One end of the vehicle will likely reach the desired setting before the other end. If this happens stop adjusting the satisfied end and keep adjusting the unsatisfied end until the overall ride quality is satisfactory.**



## Final Tightening and Adjusting

### Ride Height

We have designed most cars to have a ride height of about 2" lower than factory. To achieve the best ride quality & handling, the shock absorber needs to be at 40-60% overall travel when the car is at ride height. This will ensure that the shock will not bottom out or top out over even the largest bumps. Measuring the shock can be difficult, especially on some front suspensions. Measuring overall wheel travel is just as effective and can be much easier. Most cars will have 4-6" of overall wheel travel. One easy way to determine where you are at in wheel travel is to take a measurement from the fender lip (center of the wheel) to the ground. Then lift the car by the frame until the wheel is just touching the ground, re-measure. This will indicate how far you are from full extension of the shock. A minimum of 1.5" of extension travel (at the wheel) is needed to ensure that the shock does not top out. If you are more than 3" from full extension of the shock then you are in danger of bottoming out the shock absorber.

### Adjusting Spring Height

When assembling the CoilOver, screw the spring retainer tight up to the spring (0 preload). After entire weight of car is on the wheels, jounce the suspension and roll the car forward and backward to alleviate suspension bind.

- If the car is too high w/ 0 preload then a smaller rate spring is required. Although threading the spring retainer down would lower the car, this could allow the spring to fall out of its seat when lifting the car by the frame.
- If the car is too low w/ 0 preload, then preload can then be added by threading the spring retainer up to achieve ride height. On 2.6" - 4" stroke shocks, up to 1.5" of preload is acceptable. On 5-7" stroke shocks, up to 2.5" of preload is acceptable. If more preload is needed to achieve ride height a stiffer spring rate is required. Too much preload may lead to coil bind, causing ride quality to suffer.