



350 S. St. Charles St. Jasper, In. 47546
Ph. 812.482.2932 Fax 812.634.6632

www.ridetech.com

Part # 11393699
82-03 S-10 Upper StrongArms

Components:

1	90000429	Drivers side arm
1	90000430	Passenger side arm
2	90000899	Upper ball joint (includes boot, grease fitting, castle nut & cotter pin)
2	90003375	Caster Adjustable Cross shaft
2	70010827	Delrin Bushing – no ledge
2	70010826	Delrin Bushing – small ledge
4	70010759	Delrin Bushing – large ledge
4	90002737	Cross shaft T-washer
4	70011955	Zero Offset Caster Slugs
2	90003934	WASHER; 1.70OD
2	90003933	WASHER; 1.45OD

Hardware:

4	99622005	5/8"-18 Lock Nut	Cross shaft
4	99433004	7/16" USS Flatwasher	Cross shaft to Frame
4	99431009	7/16"-14 x 2 1/2" Bolt	Cross shaft to Frame
4	99432001	7/16"-14 Nylok Nut	Cross shaft to Frame

STRONGARMS



1. Fasten the upper arm to the frame using the supplied 7/16" hardware. Reinstall the current alignment shims, but **vehicle must be realigned**. Torque to 55 ft-lbs.

2. Drop ball joint down through upper arm. Slide ball joint boot over stud, then place boot retainer over the boot.

Torque Specs:

Upper Ball joint - 61 ftlbs and tighten to line up cotter pin.

3. Fasten the ball joint to the spindle w/ the new castle nut and cotter pin supplied.

4. Tighten the cross shaft nuts enough to create drag on the delrin bushings, the arm should still move.

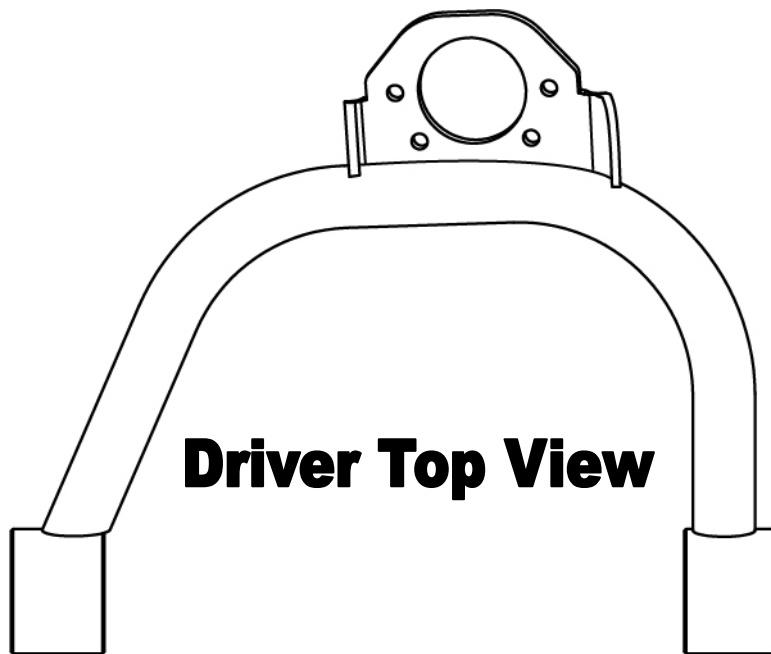

Driver Top View

Front →

STRONGARMS

Item #	Description	Qty.
1.	Driver side arm	1
	Passenger Arm – NOT SHOWN	1
2.	Caster Adjustable Cross shaft	2
3.	Delrin bushing with Large Ledge	4
4.	Delrin bushing with Small Ledge	2
5.	Inner Delrin bushing no ledge	2
6.	WASHER; 1.70OD	2
7.	WASHER; 1.45OD	2
8.	T-Washer	4
9.	5/8 – 18 Toplock Jam Nut	4
10.	Caster Slug – NOT SHOWN	4

Driver Top View

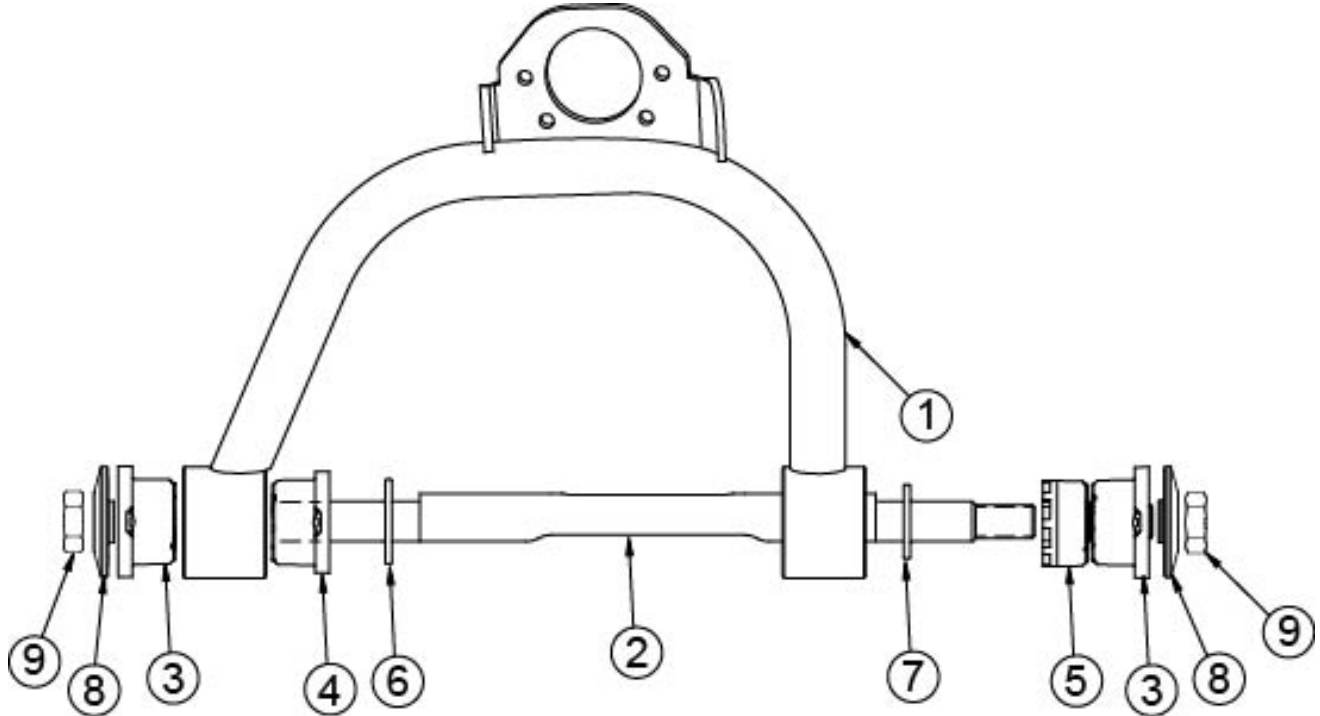

STRONG ARMS

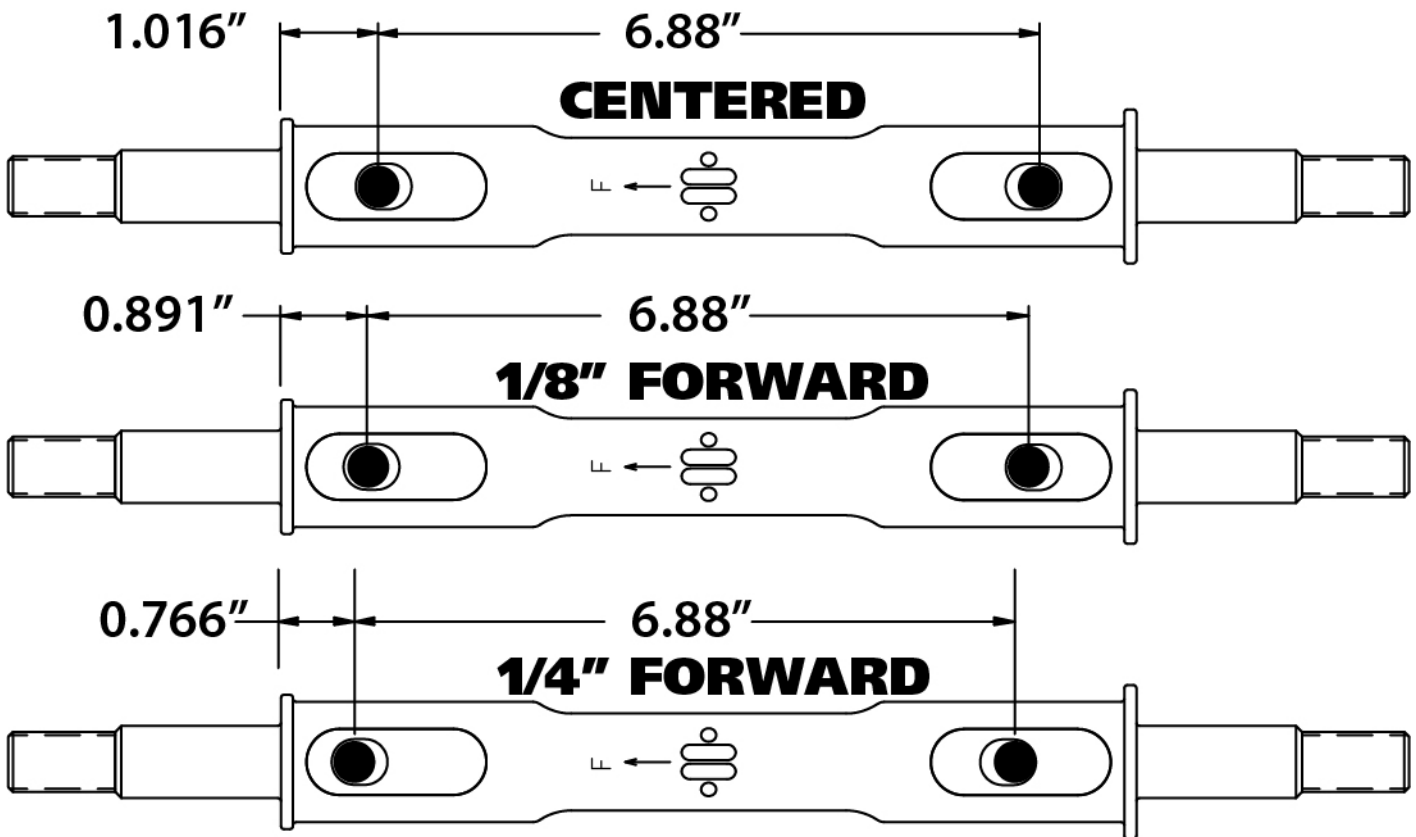

These Strong Arms come equipped with a changeable caster slug setup. This allows you to add or remove caster from the front suspension, if desired. The caster slugs that come in the kit are setup to put the control arm in the centered position, which is approximately 5 degrees of caster. The caster slugs allow you to add or remove caster without having to use a stack of shims. If more or less caster is desired, optional caster slugs can be purchased from your Ridetech dealer or Ridetech.

Caster Explained:

To understand caster you need to picture an imaginary line that runs through the upper ball joint and extends through the lower ball joint. From the side view the imaginary line will tilt forward or backward. The tilting of this imaginary line is defined as caster.

Caster is measured in degrees by using a caster camber gauge. If the imaginary line described above tilts towards the back of the car, at the top, then you will have positive caster. If the imaginary line tilts forward then you would have negative caster.

Positive caster provides the directional stability in your car. Too much positive caster will make the steering effort difficult. Power steering will allow you to run more positive caster. Negative caster requires less steering effort but can cause the car to wander down the highway.

STRONG ARMS

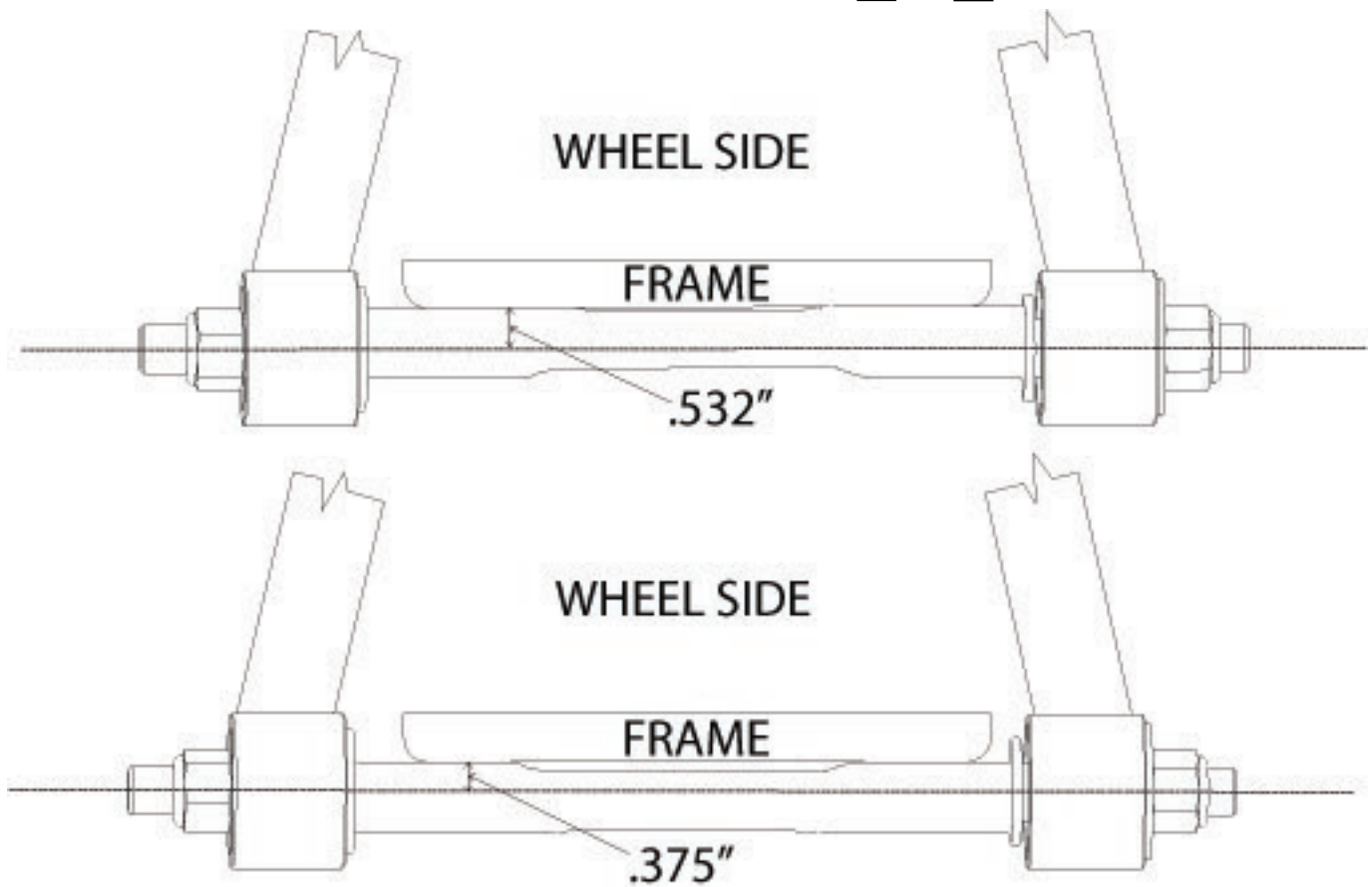

Offset Upper Cross Shaft

The cross shaft that is used in the upper control arm is offset. The offset combined with the caster slug option allows you to achieve the alignment setting you desire with minimal shims. To change the direction that the Icon faces, simply spin the cross shaft in the control arm.

If you are after an aggressive **Track or Autocross Alignment**, bolt the control arm to the frame bracket with the arm offset to the inside of the car (like the top illustration). The Ridetech Icon will be facing the engine.

If a **Street Alignment** is desired, bolt the control to the frame bracket with the arm offset to the outside of the car (like the bottom illustration). The Ridetech Icon will be facing the wheel.