

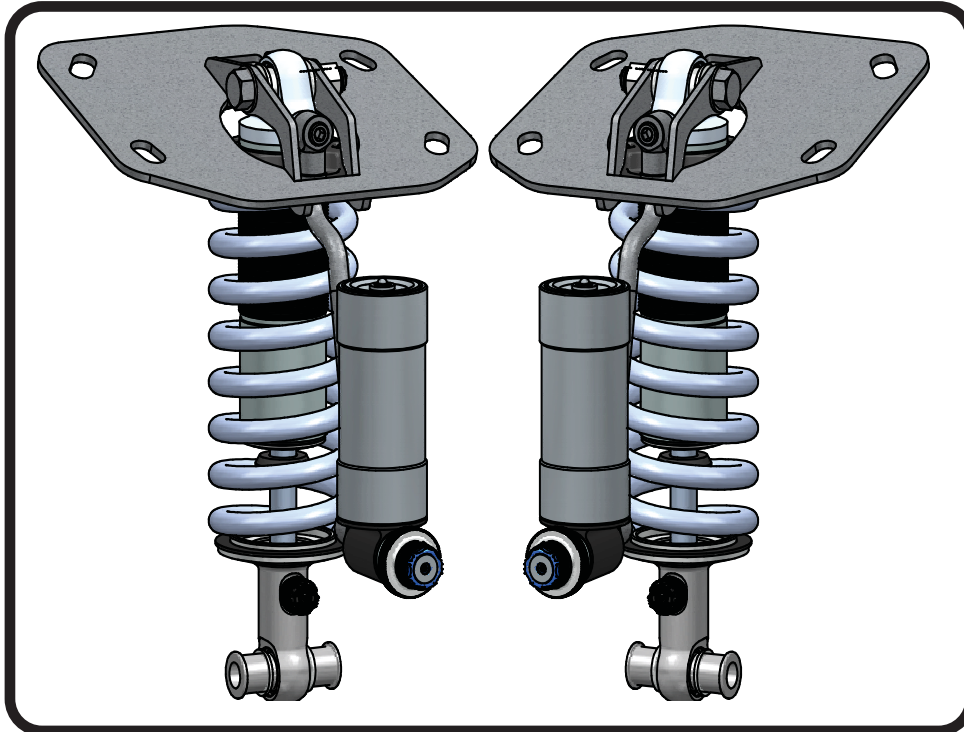

Part # 11506111 -2010-2015 Camaro

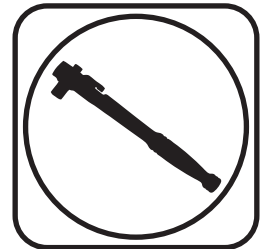

Recommended Tools



2010-2015 Camaro TQ Rear CoilOver Installation Instructions

Table of contents

Page 2.....	Included components
Page 3.....	Disassembly and CoilOver Assembly
Page 4.....	Installation of CoilOver Assembly
Page 5.....	Final Assembly
Page 6.....	CoilSpring Adjustment
Page 7-8.....	Shock Adjustment





Included ComponentsIn the box

Item #	Part #	Description	QTY
1	986-10-070	3.6" Stroke TQ Series Shock	2
2	90002025	2.7" Shock Eyelet	2
3	90002382	Driver Upper CoilOver Mount	1
3	90002383	Passenger Upper CoilOver Mount	1
4	59080500	CoilSpring 8" 500lb	2
5	70010828	Delrin Spring Washer	4
6	803-00-199(kit)	Lower Spring Adjuster Nut (803-00-199 kit)	2
7	803-00-199(kit)	Adjuster Nut Locking Screw (803-00-199 kit)	2
8	803-00-199(kit)	Upper CoilSpring Mount (803-00-199 kit)	2
9	90002043	Upper 1/2" ID Shock Spacer (NARROW)	4
10	90002381	Lower 1/2" ID Shock Spacer (WIDE)	4
	90001994	5/8" ID Bearing (installed in shock and eyelet)	4
	90001995	Bearing Snap Ring (installed in shock and eyelet)	8
	026-05-000	Reservoir Mounts (Not Shown)	4
	85000003	Hex Wrench for Reservoir Mounting Screws (Not Shown)	1
13	99501011	1/2-20 x 2 1/2" Hex Bolt	2
14	99503001	1/2" SAE Flatwasher	4
15	99502008	1/2"-20 Hex Nut	2
	99050000	5mm Socket Head Cap Screws-Reservoir Mounting (Not Shown)	12

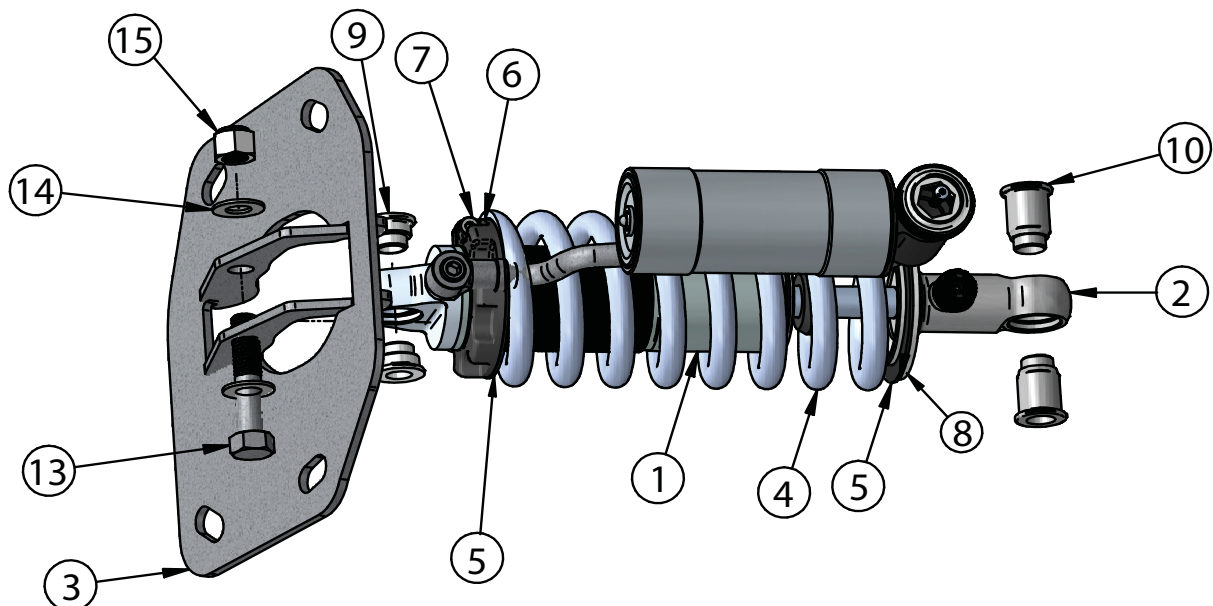



Disassembly

1. Raise the vehicle off the ground and safely support it by something other than the suspension.
2. Disconnect the swaybar linkage from the lower Control Arm.
3. Remove the bolt attaching the OEM shock setup from the lower control arm and retain it for reassembly.
4. Remove the (4) bolts attaching the upper shock mount. **Retain the bolts for reassembly,**
5. Remove the bolt that attaches the spindle to the lower control arm.
6. Swing the lower control arm down and remove the OEM shock setup.

Getting Started.....

7. The CoilOvers need to be assembled before installing the shocks in the mounts. Follow steps 8-12 below to assemble the shocks and springs.

CoilOver Assembly...



First, using the supplied lower adjuster nut (803-00-199) thread the nut onto the shock from the bottom side as seen in figure 8. Remove the plastic pellet that is in the split of the adjuster nut.



Once the knob is removed slide a Delrin washer over the eyelet. Next, slide the upper spring mount (803-00-199) over eyelet as seen in figure 11.



Next, install a delrin washer then coil spring over the top of the shock as seen in figure 9.



Install upper spring mount retainer clip (803-00-199) into the groove on the upper eyelet as seen in figure 12. Then, reinstall adjuster to complete assembly.



Before the upper spring mount can be installed screw the adjuster knob on the upper eye mount to the firmest setting (clockwise) as seen in figure 10. Then remove the Knob by holding it while removing the center screw.

Install the locking screw in the adjuster nut before setting spring preload, but DO NOT tighten until the spring preload has been set. Set the spring preload after the CoilOver has been installed.

NOTE: Remember to adjust the shock valving before driving, the shock is currently set to full stiff.



Installation of CoilOver Assembly

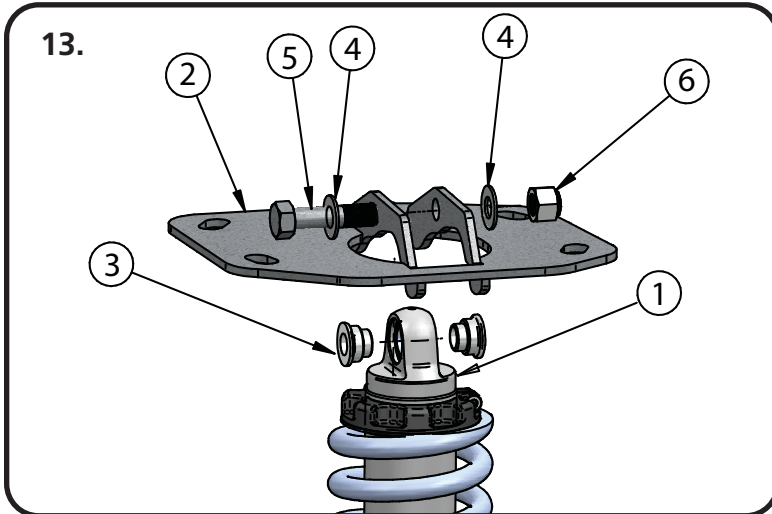

13. Install the shock body side of the CoilOver Assembly(1) into the upper mount(2) using a (90002403) spacer(3) installed into the bearing. With the spacers installed into the shock bearing, insert the Coilover into the mount aligning the holes in the mount with the thru hole in the bearing spacers. Install a 1/2" Flatwasher(4) on the 1/2 x 2 1/2" Hex bolt(5) and insert in the aligned holes. Finish by installing a 1/2" Flatwasher(4) and 1/2" Nylok nut(6) and torque the nut/bolt to 50 ftlbs.



14. Install the Coilover/Upper Mount assemble into the car using the factory hardware. There is a Driver and Passenger upper bracket. These brackets are marked accordingly. Once the assembly is installed in the car, rotate the shock eyelet so that the adjuster knob is towards the outside of the car.

Note: You will have to swing the lower arm down to get the assembly into the car.



15. Install the (90002381) spacers(1) into the bearing in the shock eyelet(2). Align the shock eyelet with the factory mounting hole. Reinstall the factory hardware and torque to 50 ftlbs to eliminate any gaps between the spacers and control arm.



Final Assembly

- 16.** Reassemble car by reinstalling the lower control arm bolt through the spindle and reattaching the swaybar linkage to the lower control arm. Tighten hardware.
- 17.** Preload the springs of the CoilOver. Follow steps **17a - 17e**.
 - 17a.** Verify the adjuster nut locking screw is installed in the adjuster nut, but not tight.
 - 17b.** Screw the spring adjuster nut up the shock body until it is snug against the spring. You should NOT be able to move the spring up and down on the shock (0 preload). Verify the upper coilspring cap is seated correctly on the upper shock eyelet.
 - 17c.** Measure from the bottom of the adjuster nut to the flat of the shock. You may want to record the measurement for reference.
 - 17d.** Using a spanner wrench, thread the adjuster nut up the shock an additional 1/2" (from the measurement you took in step 2) to preload the spring.
 - 17e.** Lock the adjusting nut in place by tightening the adjuster nut locking screw.
- 18.** Repeat steps 2-17 on the other side.
- 19.** Reinstall the rear wheels and tires and slowly lower the car to the ground.
- 20.** After the entire weight of the car is on the wheels, jounce the suspension and roll the car forward and backward to alleviate suspension bind. **THIS IS NECESSARY BEFORE MEASURING RIDE HEIGHT.**

Determining Ride Height

To achieve the best ride quality & handling, the shock absorber needs to be at 50-60% overall travel at ride height. This will ensure that the shock will not bottom out or top out over even the largest bumps. Measuring overall wheel travel is an easy, effective method of determining shock travel.

Most cars will have 4-6" of overall wheel travel. To determine where you are at in wheel travel, take a measurement from the fender lip (centerline of the wheel) to the ground. Then lift the car by the frame until the wheel is barely touching the ground and remeasure. This will indicate how far you are from full extension of the shock.

A minimum of 1.5" of extension travel (at the wheel) is needed to ensure that the shock does not top out. If you are more than 3" from full extension of the shock, then you are in danger of bottoming out the shock absorber.



CoilSpring Adjustment

- 21.** If you determine you need to adjust the ride height of the rear suspension after getting the car on the ground, follow **Steps 21a - 21e** for adjusting the ride height. This kit is designed to lower the ride height of this car approximately 1 1/2".
- 21a.** Raise the vehicle and support it by the frame, allowing the suspension to hang freely. You do NOT need to remove the rear wheels.
 - 21b.** Loosen the locking screw in the adjuster nut, but do not remove the locking screw.
 - 21c.** Measure from the bottom of the adjuster nut to the flat of the shock. You may want to record the measurement for reference.
 - 21d.** Using a spanner wrench, thread the adjuster up or down the shock to obtain the correct ride height. One complete revolution of the adjuster nut is approximately 3/32" at the wheel. Threading the adjuster nut up the shock will raise the ride height, threading it down will lower the ride height.
 - 21e.** Lock the adjusting nut in place by tightening the adjuster nut locking screw.
- 22.** Set the vehicle back on the ground, jounce the suspension and roll the car forward and backward to alleviate suspension bind. **THIS IS NECESSARY BEFORE MEASURING RIDE HEIGHT.**
- 23.** Recheck your ride height. If you need to readjust, repeat **Steps 21-22**.
- 24.** Once your desired ride height has been achieved, you may need to adjust your shocks to achieve your desired ride quality. See pages 7 and 8.



Shock Adjustment

Shock Adjustment 101- Single Adjustable

Rebound Adjustment:

How to adjust your new shocks.

The rebound adjustment knob is located on the top of the shock absorber protruding from the eyelet.

You must first begin at the ZERO setting, then set the shock to a soft setting of 20.



-Begin with the shocks adjusted to the ZERO rebound position (full stiff). Do this by rotating the rebound adjuster knob clockwise until it stops.



-Now turn the rebound adjuster knob counter clock wise 20 clicks. This sets the shock at 20. (settings 21-24 are typically too soft for street use).

Take the vehicle for a test drive.



-if you are satisfied with the ride quality, do not do anything, you are set!

-if the ride quality is too soft increase the damping effect by rotating the rebound knob clock wise 3 clicks.

Take the vehicle for another test drive.



-if the vehicle is too soft increase the damping effect by rotating the rebound knob clock wise 3 additional clicks.



-If the vehicle is too stiff rotate the rebound adjustment knob counter clock wise 2 clicks and you are set!

Take the vehicle for another test drive and repeat the above steps until the ride quality is satisfactory.

Note:

One end of the vehicle will likely reach the desired setting before the other end. If this happens stop adjusting the satisfied end and keep adjusting the unsatisfied end until the overall ride quality is satisfactory.



Shock Adjustment

Shock Adjustment 101-Triple Adjustable

Triple Adjustable:

Step One: High Speed Compression



- High speed compression adjustments are used in both street driving and track tuning.
- Begin with the shocks adjusted to the ZERO high speed compression position (full stiff). Do this by rotating the high speed compression adjuster (large knob) clockwise until it stops.
- Now turn the high speed compression adjuster knob counter clock wise 20 clicks. This sets the shock at 20. (settings 21-24 are typically too soft for street use. For typical street driving the high speed compression adjuster will remain at setting 20.

Step Two: Low Speed Compression

Low speed compression adjustment is what is typically felt during street driving.



- Begin with the shocks adjusted to the ZERO low speed compression position (full stiff). Do this by rotating the low speed compression adjuster (small knob) clockwise until it stops.
- Now turn the low speed compression adjuster knob counter clock wise 20 clicks. This sets the shock at 20. (settings 21-24 are typically too soft for street use). Take the vehicle for a test drive.
- if you are satisfied with the ride quality, do not do anything, you are set!
- if the ride quality is too soft increase the damping effect by rotating the low speed compression knob clock wise 3 clicks.

Take the vehicle for another test drive.



- if the vehicle is too soft increase the damping effect by rotating the low speed compression knob clock wise 3 additional clicks.
- If the vehicle is too stiff rotate the low speed compression adjustment knob counter clock wise 2 clicks and you are set!

Take the vehicle for another test drive and repeat the above steps until the ride quality is satisfactory.

Step 3:

Adjust rebound according to Single Adjustable instructions.

Note:

One end of the vehicle will likely reach the desired setting before the other end. If this happens stop adjusting the satisfied end and keep adjusting the unsatisfied end until the overall ride quality is satisfactory.