



Part # 11510101- 1997-2013 C5/C6 Corvette Touring Package

Recommended Tools

Kit Components:

11519500	Delrin Control Arm Bushing Kit
11510110	HQ Smooth Body Shock Kit
11519120	Front SwayBar Instructions
11519122	Rear SwayBar Instructions

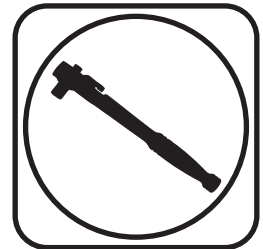

1997-2013 Corvette Touring Package Installation Instructions

Table of contents

Pages	2-8.....	Delrin Bushing Kit
Pages	9-14.....	Smooth Body Shocks
Pages	15-17.....	Front SwayBar
Pages	18-20.....	Rear SwayBar





Part # 11519500 - 97-13 Corvette Delrin Bushing Kit



Recommended Tools

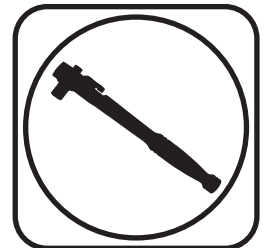

1997-2013 Delrin Control Arm Bushing Kit Installation Instructions

Table of contents

- Page 3..... Included components
- Page 4..... Bushing Dimensions
- Page 5..... Disassembly and Front Upper
- Page 6..... Front Upper Bushing Installation
- Page 7..... Front Lower
- Page 8..... The Finish





Included ComponentsIn the box

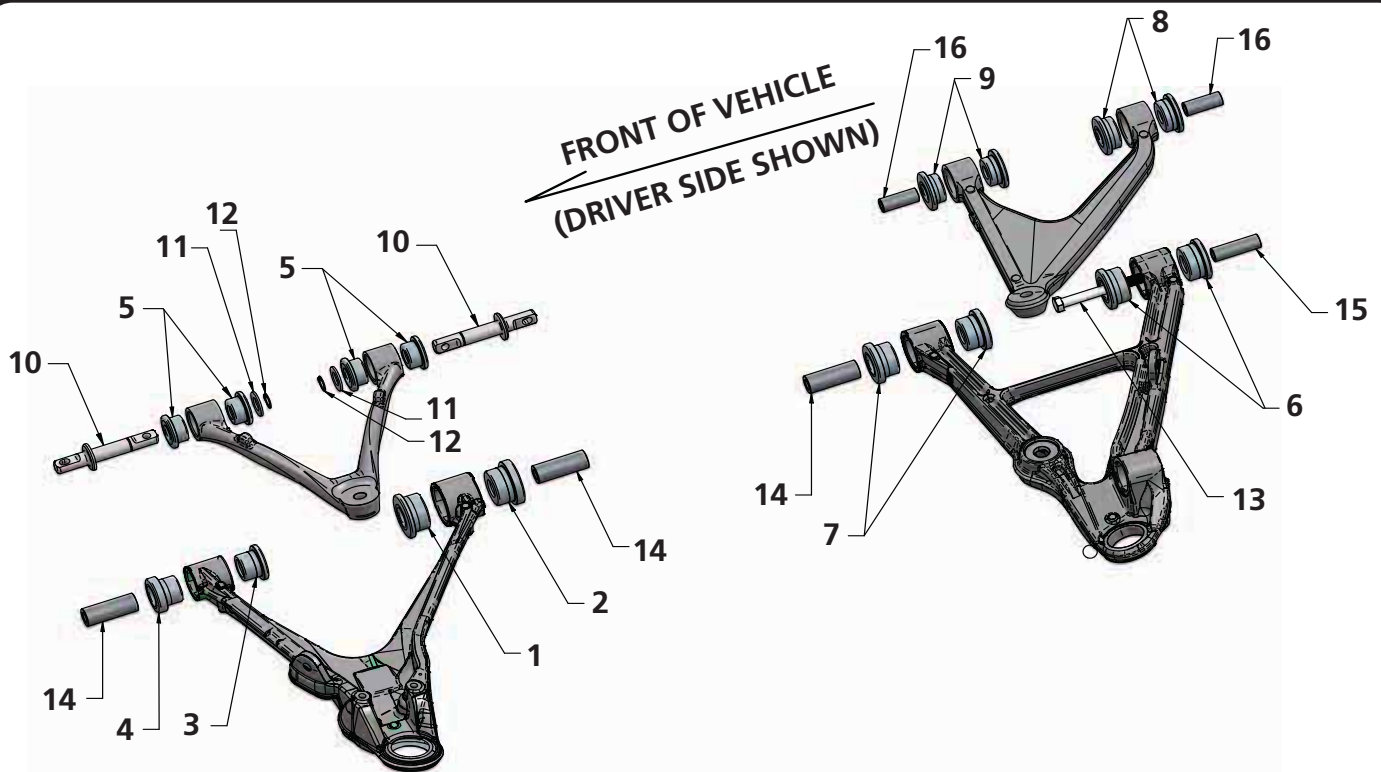

Item #	Part #	Description	QTY
1	70012110	Front Lower Control Arm Large Inner Bushing	2
2	70012111	Front Lower Control Arm Large Outer Bushing	2
3	70012112	Front Lower Control Arm Small Inner Bushing	2
4	70012113	Front Lower Control Arm Small Outer Bushing	2
5	70012114	Front Upper Control Arm Bushing	8
6	70012115	Rear Lower Control Arm Bushing; Large	4
7	70012116	Rear Lower Control Arm Bushing; Small	4
8	70012117	Rear Upper Control Arm Bushing; Large	4
9	70012118	Rear Upper Control Arm Bushing; Small	4
10	90002125	Front Upper Trunnion	4
11	99753006	3/4" I.D. Washer	4
12	90001634	3/4" Snap Ring	4
13	99501034	1/2"-13 x 4 1/2" Hex Bolt, Flat Washer, & Nylok Nut	2
14	90002544	Inner Sleeve; 1.00" OD x .562" ID x 2.717" OAL	6
15	90002545	Inner Sleeve; 1.00" OD x .500" ID x 2.480" OAL	2
16	90002546	Inner Sleeve; .750" OD x .482" ID x 1.929" OAL	4



Bushing & Sleeve Dimensions

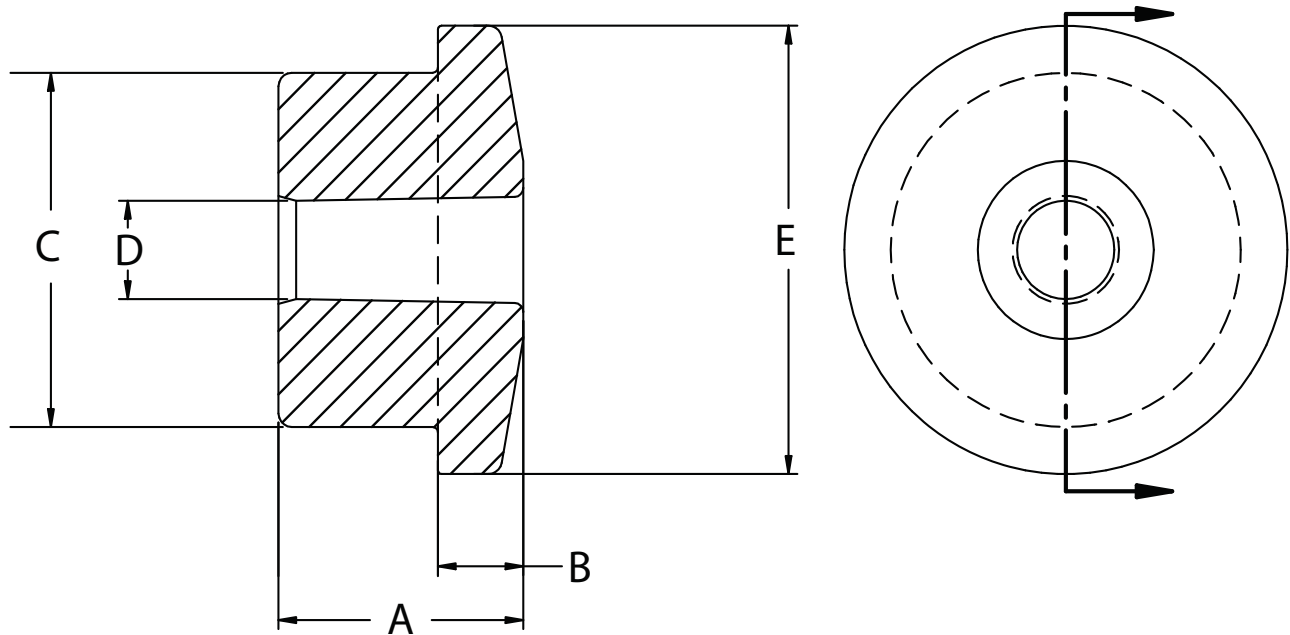

Bushing Dimensions

Item #	Part #	A	B	C	D	E
1	70012110	1.271	.371	1.975	1.00	2.500
2	70012111	1.381	.481	1.975	1.00	2.500
3	70012112	1.252	.315	1.464	1.00	1.950
4	70012113	1.454	.516	1.464	1.00	1.950
5	70012114	.900	.250	1.418	.750	1.850
6	70012115	1.162	.337	1.895	1.00	2.250
7	70012116	1.275	.400	1.777	1.00	2.250
8	70012117	.895	.295	1.737	.750	2.142
9	70012118	.895	.295	1.580	.750	2.142

Inner Sleeve Dimensions

Item #	Part #	OD	ID	Over All Length
14	90002544	1.00"	.562"	2.717"
15	90002545	1.00"	.500"	2.480"
16	90002546	.750"	.482"	1.929"



Disassembly

Congratulations on your purchase of the Ridetech C5/C6 Control Arm Delrin Bushing Kit. This kit has been designed to help improve your Corvette's handling along with providing a lifetime of enjoyment. The Delrin Bushing Kit will improve your Cars handling characteristics by eliminating the deflection at the bushing.

1. We recommend doing one Control Arm at a time to simplify installation of the bushings.

A Bench Vise is needed for the removal and installation of the Bushings.

2. Raise the vehicle and support it by the frame or rear crossmember, allowing the suspension to hang freely.
3. With the Wheels and Tires removed, disconnect the Shocks, Springs, and Sway Bar Linkage from the Lower Control Arms, retaining the hardware.
4. Support the Rotor Assembly when removing any of the Control Arms to prevent unnecessary strain on the Brake Lines and ABS Sensor Wires.

Ridetech sells a Tool, part number 85000006, to aid in the removal of the bushings.

Front Upper Trunnion & Bushing Removal

5. With the Rotor and Hub supported, remove the Front Upper Control Arm by , first removing the balljoint nut and using a balljoint separator to release the balljoint from the Control Arm.
6. Next, remove the (4) bolts attaching the Trunnion to the car. Mark any shims that may be behind the Trunnion. You will need to put these back in the same location when reinstalling the Control arm.
7. With the end of the Trunnion clamped in a Bench Vise, use a twisting motion to remove the Trunnion and Bushing assembly from the Control Arm. Do this for both Trunnions.

Note: The use of Penetrating Oil can help with the removal of the Trunnion and Bushing.

8. Once the Bushing Assembly is removed from the arm, prep the bushing opening by cleaning it to remove any debris that may be left in the opening.
9. Use the Illustration on Page 2 to determine the parts needed for the Delrin Bushing & Trunnion installation in the upper arm. To do (1) Arm, you will need (4) Front Upper Control Arm Bushings[5]. There are (8) of these Bushings in the kit. You will also need (2) Trunnions[10], (2) 3/4" ID Washers[11], and (2) Snap Rings[12].



Front Upper Bushing Installation

10.

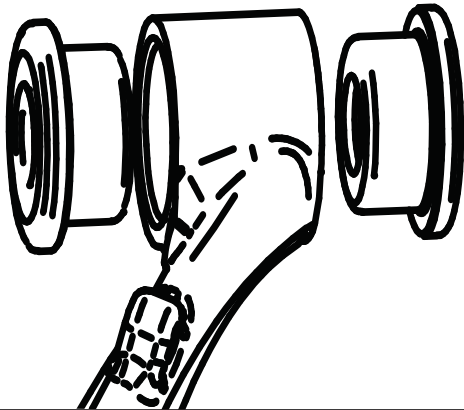

10. Press a set of bushings into each opening of the upper control arm. A bench vise can be used to do this.

11.

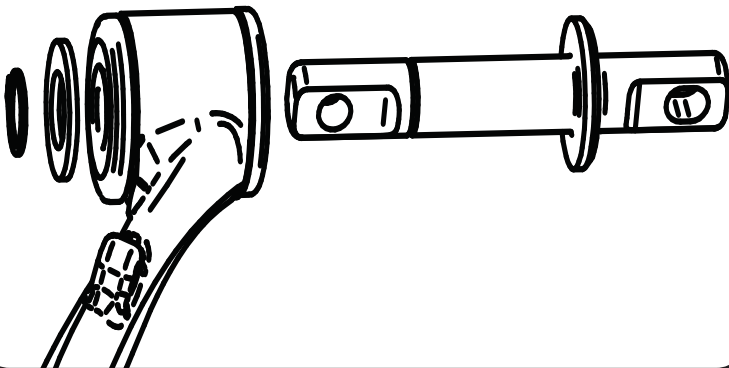

11. Install a Trunnion into each set of Bushings installed in the Control Arm. The Trunnions are inserted with the Shoulder to the outside of the Control Arm. Install a 3/4" Washer followed by a Snap Ring on each Trunnion.

12.

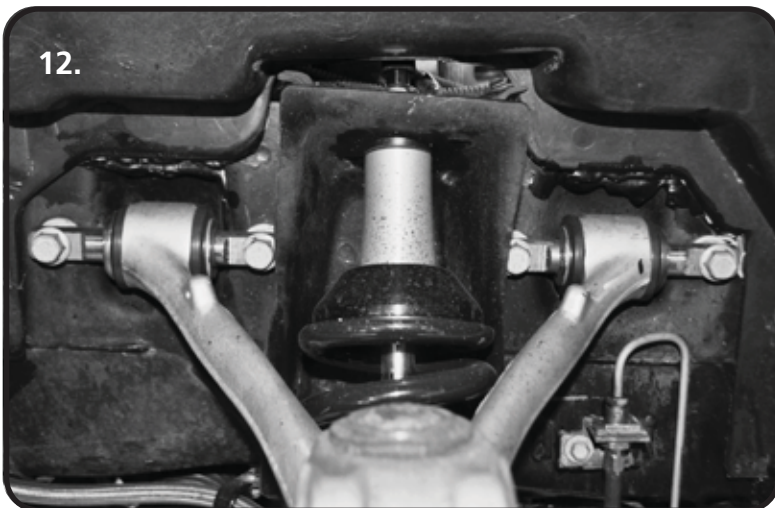

12. Reinstall the Control Arm on the car with any shims back into their previous location. Tighten all Fasteners.

**Control Arm Mounting Bolts Torque Spec:
48 ftlbs**

Repeat on other side.



Front Lower

13.



13. With the upper reattached, it is time to do the Lower Control Arm. Ridetech sells tool 85000006 to aid in removal of the bushings. The Tool is 2-sided with a large opening for the Lower Bushings and the opposite side being smaller for the Rear Upper Bushings. It comes with a Mandrel to insert into the center sleeve for pushing the Bushings out of the Control Arm.

14.



14. Before removing the Lower Control Arms, **use a Marker or something similar to mark the Lower Control Arm Eccentrics.** Also, mark the location of the bolts. The marks will get the Alignment close, but Ridetech recommends getting the alignment checked after the install is completed.

15.

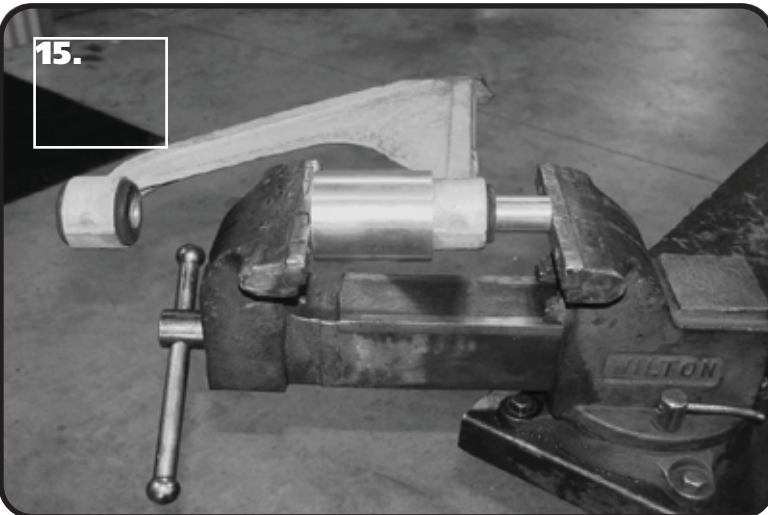

15. Remove the Lower Control Arm. Using the Ridetech tool (with large side over bushing) and a Bench Vise, push out the original Bushings. Clean out the opening of any debris that may have been left behind.



Finishing

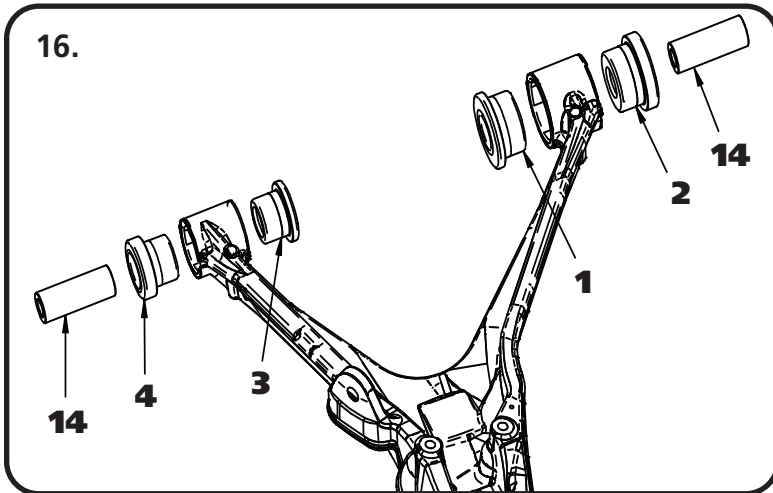

16. Using the Diagrams on Page 2 & 3, Insert the correct Bushings in the correct locations using a Bench Vise to push them in. Push the Bushings in followed by the correct Inner Sleeve. The Front Lower uses Bushing 1, 2, 3, 4, and Inner Sleeve 14

Reinstall Arm and repeat for other side. Align the marks that were put on the Eccentric in Step 14 and tighten the Hardware.

17. Repeat Steps 13-16 on the remainder of the Control Arms and Bushings using the Diagrams on Page 2 & 3 for Bushing Location. Install 1/2" x 4 1/2" Bolt, washers and Nylok Nut in the Rear Bushing of the Rear Lower Control Arm. **Be sure to mark the Eccentrics and Bolt location.** The simplest way to do the install is to do one arm at a time.

Torque Specs:

Front Lower Control Arm Cam Nuts	-	125 ftlbs
Rear Upper Control Arm Mounting Bolts	-	81 ftlbs
Rear Lower Control Arm, Front Cam Nut	-	107 ftlbs
Rear Lower Control Arm, Rear Cam Nut	-	70 ftlbs

WAIT UNTIL REAR SWAYBAR INSTALL

18. Reattach the Springs and install the NEW Smooth Body Shocks and SwayBars.

19. After installing all Bushings, it is recommended to get the Corvette Alignment checked.



Part # 11510110 - 1998-2013 C5/C6 HQ Series Shocks

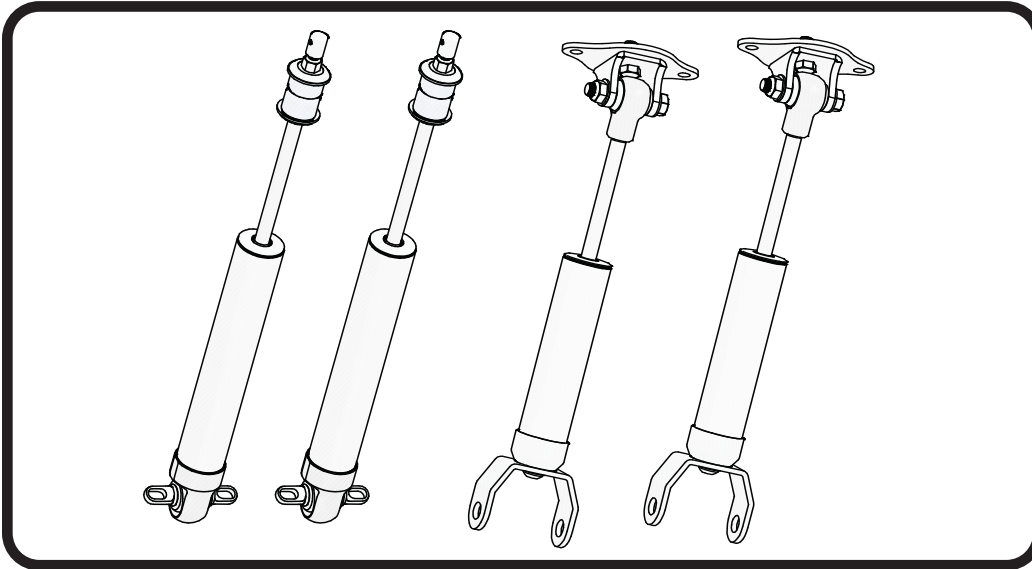

Recommended Tools

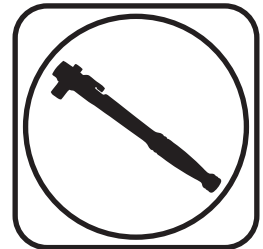

1998-2013 C5/C6 HQ Series Shocks Installation Instructions

Table of contents

Pages	10-11.....	Front HQ Shocks
Pages	12-13.....	Rear HQ Shocks
Page	14.....	Shock Adjustment





1998-2013 C5/C6 HQ Front Smooth Body Shocks

Major ComponentsIn the box

Item #	Part #	Description	QTY
1	22879599	6.5" Stroke Shock	2
2	70011139	5/8" ID Shock Bushing	2
3	90002068	Wide Trunnion	2
4	70012188(kit)	Bushing Support Washer	4
5	70012188(kit)	Stem Bushing	4
6	99372006	3/8"-24 Thin Jam Nut	4

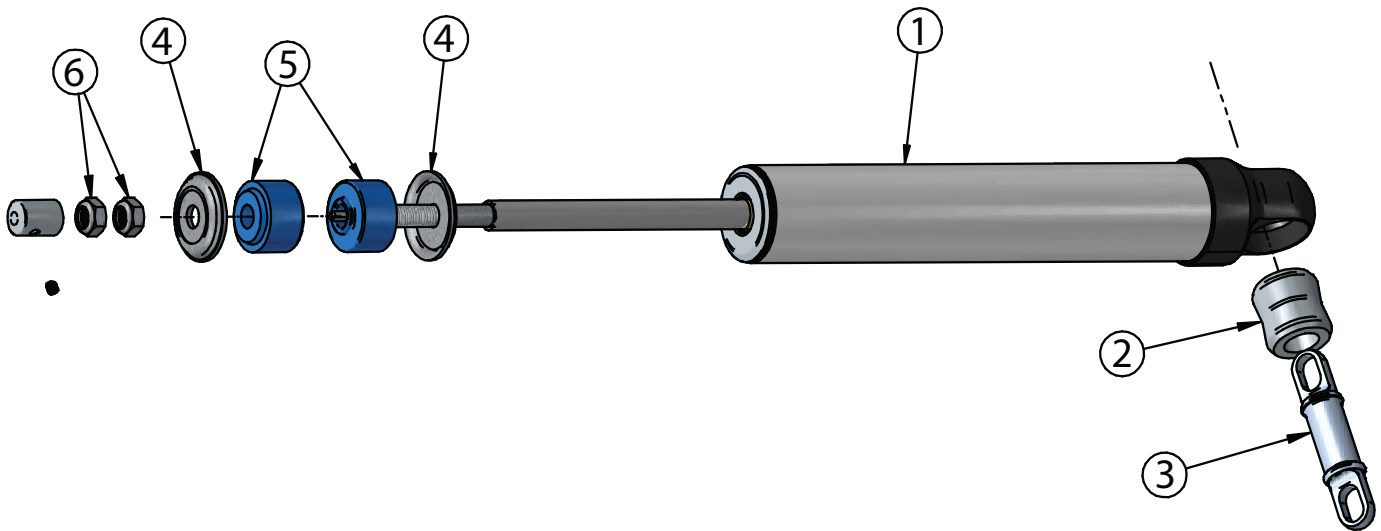



CoilOver Installation

1.

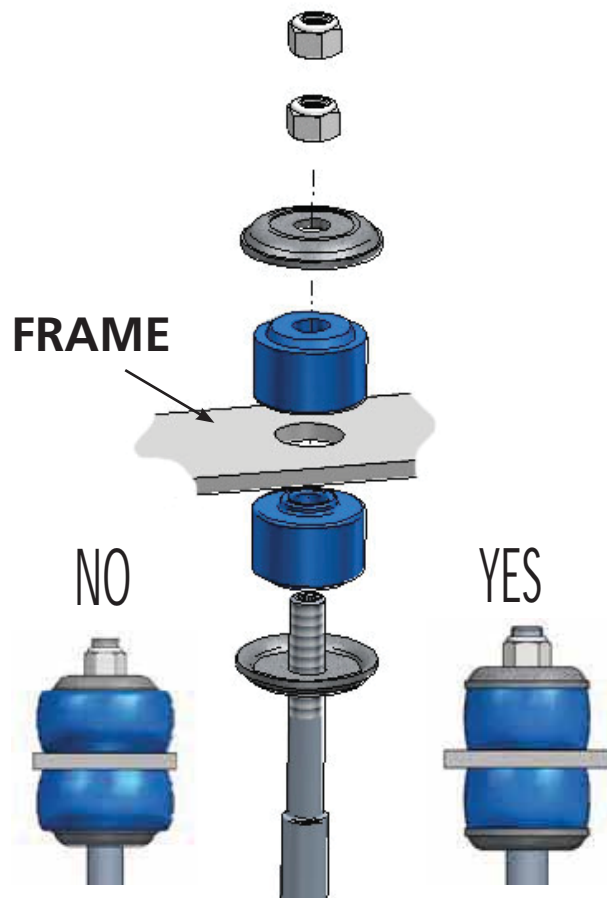

1. With the OEM Shock removed, install the RideTech shock. Install a Bushing Support Washer on to the shock shaft followed by a Shock Stem Bushing. Insert the assembly through the factory shock hole in the frame. With the shock stud sticking through the frame, install a Shock Stem Bushing on to the shock stud followed with a Bushing Support Washer. Install a 3/8"-24 Thin Jam nut onto the threads and tighten. Tighten until the bushing is tight, but not to the point to where the bushing is bulging past the Support Washer. Install the 2nd 3/8-24 Thin Jam nut and tighten it against the first nut.

2.

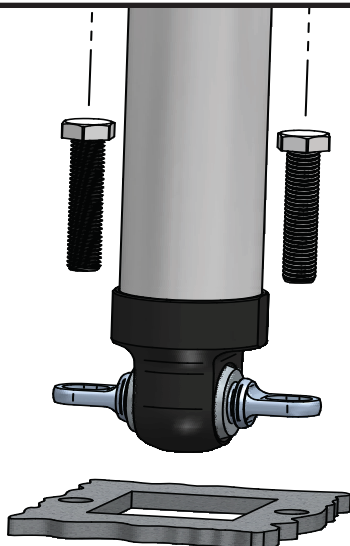

2. Attach the Trunnion to the OEM Control arm using the OEM hardware. It may be necessary to rotate the Trunnion to get it in the correct position. This can be done by sticking a screwdriver in one of the slots and spinning the trunnion in the shock bushing.



1998-2013 C5/C6 HQ Rear Smooth Body Shocks

Major ComponentsIn the box

Item #	Part #	Description	QTY
1	986-10-038	3.85" Stroke HQ Series Shock	2
2	70011489	Lower Shock Mount (Attached to Shock)	2
3	90002128	Upper Shock Mount - Driver	1
3	90002129	Upper Shock Mount - Passenger (Not Shown)	1
4	70011138	3/4" ID Shock Bushing	2
5	90002106	1/2" ID Shock Sleeve	2
6	99371040	3/8"-24 x 5/8" S.S. Button Head (Installed in shock)	2
7	99501032	1/2"-13 x 2 1/2" S.S. Hex Bolt	2
8	99502011	1/2"-13 S.S. Nylok Locknut	2

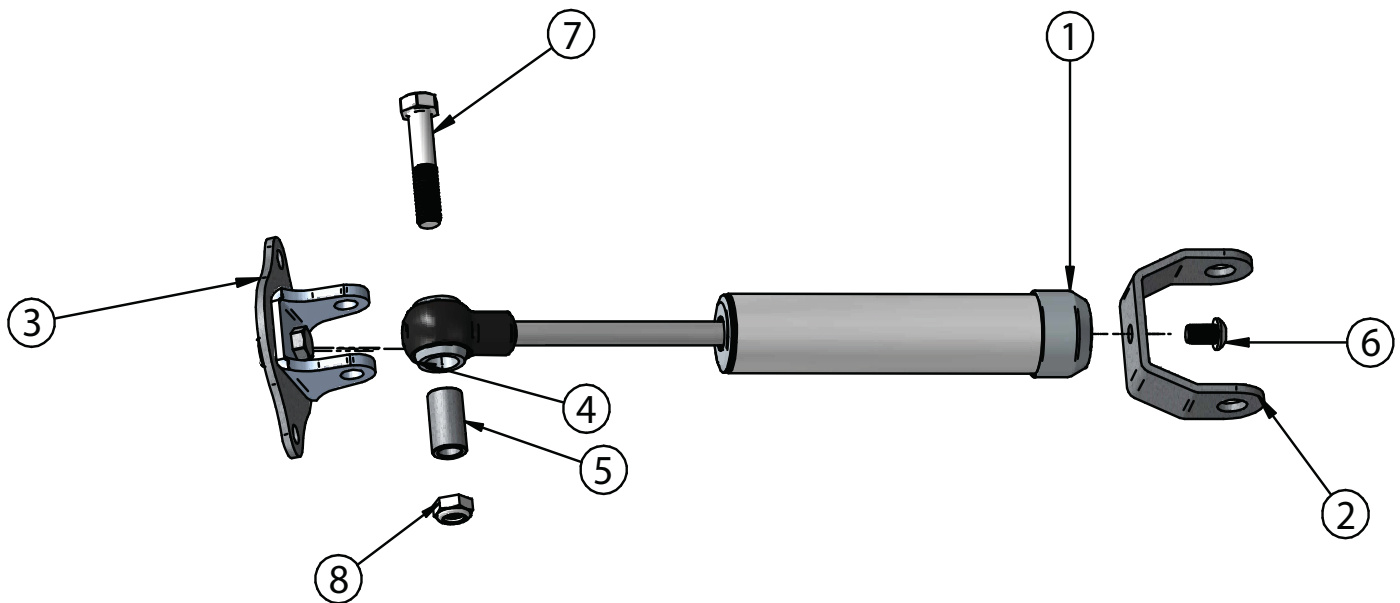



CoilOver Assembly

1.

PASSENGER

DRIVER



2.

FRONT

OFFSET

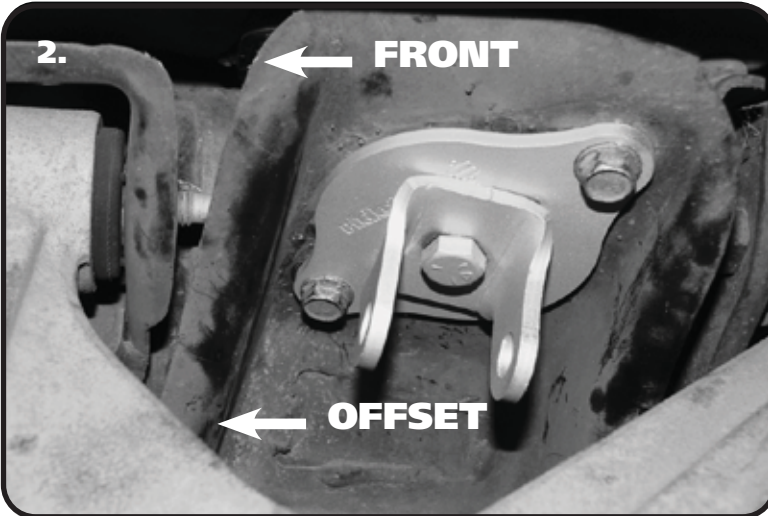

3.

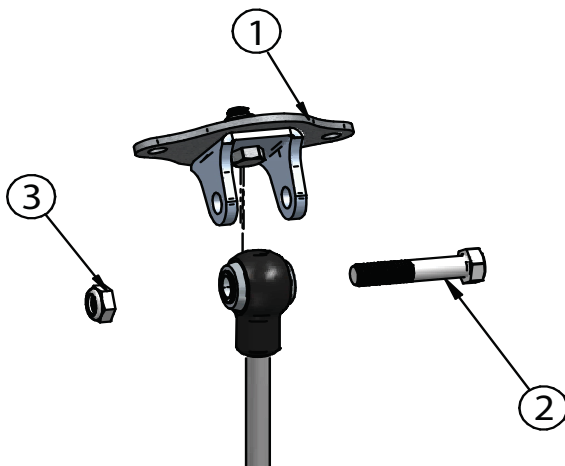

1. Start by removing the OEM shock. With the shock removed start installing the New HQ Series shocks. The Upper Mount will be replaced with mounts included in the Shock Kit. The new Upper Mounts will offset the Shock to the front of the Corvette. When these mounts are installed correctly, the Upper Mounting Bolt will be PARALLEL with the Lower Mounting Bolt.

2. Install the upper mount into the car using the factory hardware. The Mount will have the top of the Shock OFFSET TO THE FRONT OF THE CAR.

3. With the upper mount installed insert the Shock assembly into the upper shock mount(1). Align the holes in the bracket with the hole in the Shock sleeve and insert the 1/2" Bolt(2). With the Bolt insert install a 1/2" Nylok Nut(3) and tighten. With the upper Shock installed, attach the lower mount to the OEM mount on the Control arm and attach with the OEM hardware.



Shock Adjustment

Shock adjustment 101- Single Adjustable

Rebound Adjustment:

How to adjust your new shocks.

The rebound adjustment knob is located on the top of the shock absorber protruding from the eyelet or stud top. You must first begin at the ZERO rebound position, then set the shock to a street setting of 12.



-Begin with the shocks adjusted to the ZERO rebound position (full stiff). Do this by rotating the rebound adjuster knob clockwise until it stops.

-Now turn the rebound adjuster knob counter clock wise 12 clicks. This sets the shock at 12. (settings 21-24 are typically too soft for street use).

Take the vehicle for a test drive.



-if you are satisfied with the ride quality, do not do anything, you are set!

-if the ride quality is too soft increase the damping effect by rotating the rebound knob clock wise 3 clicks.

Take the vehicle for another test drive.



-if the vehicle is too soft increase the damping effect by rotating the rebound knob clock wise 3 additional clicks.

-If the vehicle is too stiff rotate the rebound adjustment knob counter clock wise 2 clicks and you are set!

Take the vehicle for another test drive and repeat the above steps until the ride quality is satisfactory.

Note:

One end of the vehicle will likely reach the desired setting before the other end. If this happens stop adjusting the satisfied end and keep adjusting the unsatisfied end until the overall ride quality is satisfactory.



Part # 11519120 - 1997-2013 C5/C6 Front SwayBar



Recommended Tools



1997-2013 C5/C6 Front SwayBar Installation Instructions

Table of contents
Page 16..... Included Components and Hardware List
Page 17..... SwayBar Installation

Hardware Torque Specifications

Bushing Strap	43 ftlbs
End Link Nuts.....	53 ftlbs

Major ComponentsIn the box

Part #	Description	QTY
90001231	Front Sway Bar	1
70012394	Delrin Sway Bar Bushing Liner	2
70014280	Sway Bar Bushing	2
90001443	Bushing Strap Spacer	4
90001265	12mm End Link Adapter Bushing - Thin	2
90001264	End Link Adapter Spacer - Thick	2

END LINK ASSEMBLY

Part #	Description	QTY
90002573	12mm 90 Degree End Link	4
90001263	End Link Spacer	2

Getting Started.....

FOR THE BEST PERFORMANCE, WE RECOMMEND USING RIDETECH'S REAR SWAYBAR. THE PART NUMBER FOR THE REAR SWAYBAR IS 11519122.

This Sway Bar Kit utilizes a Delrin Liner in the Sway Bar Bushing. The Delrin Liner allows the Sway Bar to move freely and quietly in the Bushing. The Delrin is self-lubricating, no lubrication is required.

NOTE: THIS KIT UTILIZES THE OEM BUSHING STRAPS AND MOUNTING HARDWARE.

1. Jack the vehicle up to a safe working height and support with jack stands. Make sure the jack stands are stable before working under the car.

2. Remove the stock sway bar.

3. Remove the OEM end links.



4. Open the Delrin Liner at the split and slip it over the Sway Bar. Position it in the area that the bushing will ride based on the location of the stock swaybar. Do this on both ends of the swaybar.



5. Open the Sway Bar Bushing at the split and slide it **OVER** the Delrin Liner. The Bushing needs to be installed with the TAB upward and the radius to the rear. Do this on both Delrin Liners. **Images 5 & 6** illustrate the correct positioning of the bushings.

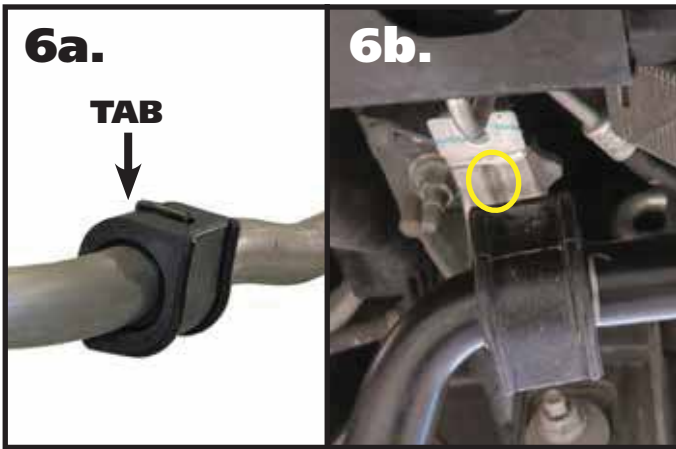

6a & 6b. Image 6a illustrates the proper positioning of the swaybar bushing. **6b.** Slide the Sway Bar into position on the car with the Sway Bar arms below the tie rods. The TAB of the bushing will nest into a SLOT in the cradle.



7. While holding the swaybar in position, reinstall the OEM bushing straps using the OEM hardware. Leave the hardware loose until the linkage is attached to the swaybar.



8. If you are experiencing an excessive gap between the cradle and bushing straps, install the (4) supplied spacers between the strap and cradle. Excessive gap would be 5/16" or more.



9. Thread the jam nuts all the way up the threads of the 90 degree ends. Evenly thread an end link into each end of the spacer until they bottom out. Adjust the endlinks out until they are pointing in opposite directions of each other. Attach the Linkage to the OEM sway bar tab on the lower control arm with the threads pointing forward. Torque the hardware.

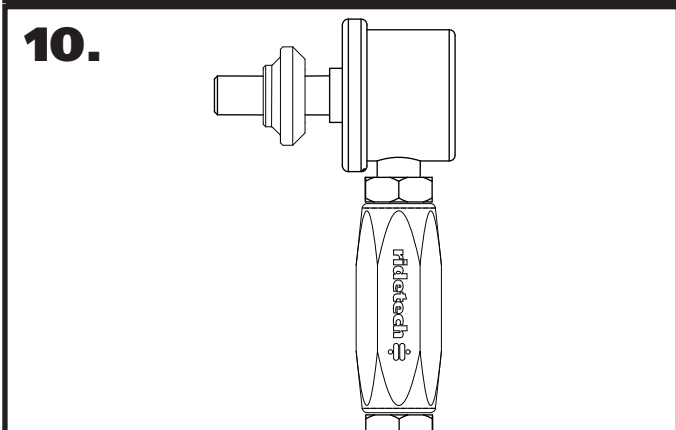

10. Slide the THICK T-bushing onto the stud of the loose end link. Use **Image 10** as a reference for proper direction of the t-bushing. The end links are supplied with the jam nuts, you will need to tighten the jam nuts once the end links are installed. They can be adjusted to ensure zero preload on the bar.

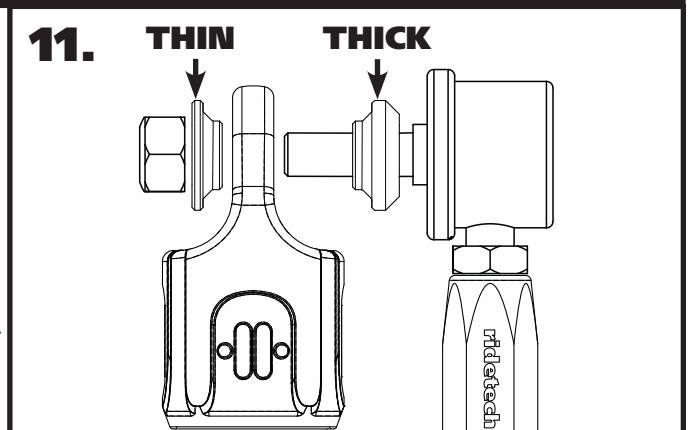

11. Insert the T-bushing/End link into the end of the swaybar. Install the THIN T-bushing onto the threads of the end link that are sticking through the swaybar end. Install the Nut supplied on the end link and torque the nuts. Torque the bushing strap hardware and tighten the end link jam nuts.



Part # 11519122 - 1997-2013 C5/C6 Rear SwayBar



Recommended Tools

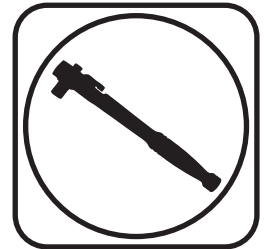

1997-2013 C5/C6 Rear SwayBar Installation Instructions

Table of contents	
Page 19.....	Included Components and Hardware List
Page 20.....	SwayBar Installation

Hardware Torque Specifications	
Upper Bushing Strap	49 ftlbs
Lower Bushing Strap	70 ftlbs
End Link Nuts.....	53 ftlbs
Clamp On Ends.....	35 ftlbs

Major ComponentsIn the box

Part #	Description	QTY
90001232	Rear SwayBar	1
70015012	Lined Sway Bar Bushing	2
90001250	Sway Bar Bushing Strap	2
90001266	Clamp On End	2
70014301	Clamp Collars	2

END LINK ASSEMBLY

Part #	Description	QTY
90002573	12mm 90 Degree End Link	4
90001263	End Link Spacer	2

HARDWARE

Part #	Description	QTY
99371054	3/8"-16 x 7/8" Socket Head Cap Screw	4
90002276	Antisieze	1

Getting Started.....

This SwayBar is adjustable to help tune the handling of your Corvette. You can adjust it by loosening the Clamp On End and sliding it in or out on the bar. With the Clamp On End slide out even with the end, the bar rates at 400 lbs. With the Clamp on end slid in 3" from the end, it rates at 775 lbs. It changes approximately 125 lbs each inch slid in from the ends. The position is going to vary depending other suspension components installed and driving style. It is safest to start with the clamp on mount even with the end and tune from there.

This sway bar kit utilizes a anti-friction lining in the sway bar bushing. The lining allows the sway bar to move freely and quietly in the bushing. No lubrication is required.

NOTE: THIS KIT UTILIZES THE OEM BUSHING STRAP MOUNTING HARDWARE.

1. Jack the vehicle up to a safe working height and support with jack stands. Make sure the jack stands are stable before working under the car.
2. Remove the stock sway bar.
3. Remove the OEM end links.



4. Open the Sway Bar Bushing at the split and slide it on the sway bar.. Position it in the area that the bushing will ride based on the location of the stock swaybar. Do this on both ends of the swaybar.



5. Slip the Bushing Straps over the SwayBar Bushings.

Note: Our Optional Billet Mount is shown in the pictures.



6.

6. Insert the swaybar into position with the center bending down and the ends going forward. Use the OEM hardware to hold the swaybar in place. Center the bar side to side before tightening the hardware. Torque the lower nut to 70 ftlbs, torque the upper bolt to 49 ftlbs.



7.

7. Install the locking rings on the outside of each bushing assembly. Use a hex key to take the locking ring apart. Reassemble it on the bar positioned next to the outside of the bushing assembly. Push the locking ring up against the bushing assembly and tighten.



8.

8. Apply Antisieze to the (4) 3/8"-16 x 7/8" Socket Head Cap Screws, thread them into the Clamp-On Ends. Install a clamp-on end on each end of the bar. The End Link mounting hole should be mounted to the outside of the bar and pointing up. Start with the mount flush with the end of the bar. Do not tighten the mount at this time.



9

9. Thread the jam nuts all the way up the threads of the 90 degree ends. Evenly thread an end link into each end of the spacer until they bottom out. Adjust the endlinks out until they are pointing in opposite directions of each other. Install the end links using **Image 10** as a reference. Install both end links before tightening the end link hardware.



10.

10. Sit the car on the ground to tighten the clamp on mounts. With the car on the ground, position the clamp ends so that the end link studs are parallel with each other. Torque the end link mounting nuts to 53 ftlbs. Torque the clamp ends evenly to 35 ftlbs. Tighten linkage jam nuts. Retorque the clamp ends anytime you do a rate adjustment.