

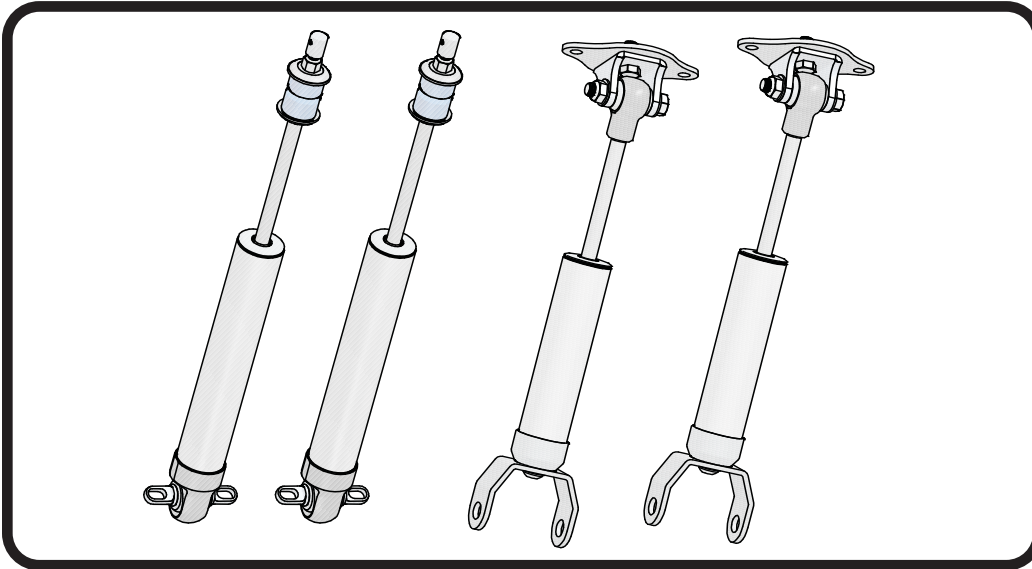

**Part # 11510110 - 1998-2013 C5/C6 HQ Series Shocks**

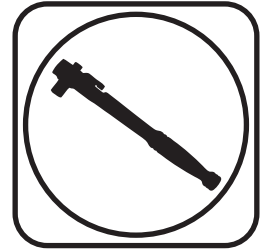

Recommended Tools



## 1998-2013 C5/C6 HQ Series Shocks Installation Instructions

### Table of contents

Pages	2-3.....	Front HQ Shocks
Pages	4-5.....	Rear HQ Shocks
Page	6.....	Shock Adjustment





### 1998-2013 C5/C6 HQ Front Smooth Body Shocks

#### Major Components .....In the box

Item #	Part #	Description	QTY
1	22879599	6.5" Stroke Shock	2
2	70011139	5/8" ID Shock Bushing	2
3	90002068	Wide Trunnion	2
4	70012188(kit)	Bushing Support Washer	4
5	70012188(kit)	Stem Bushing	4
6	99372006	3/8"-24 Thin Jam Nut	4
	008-03-012	Bumpstop (installed on shock shaft)	2

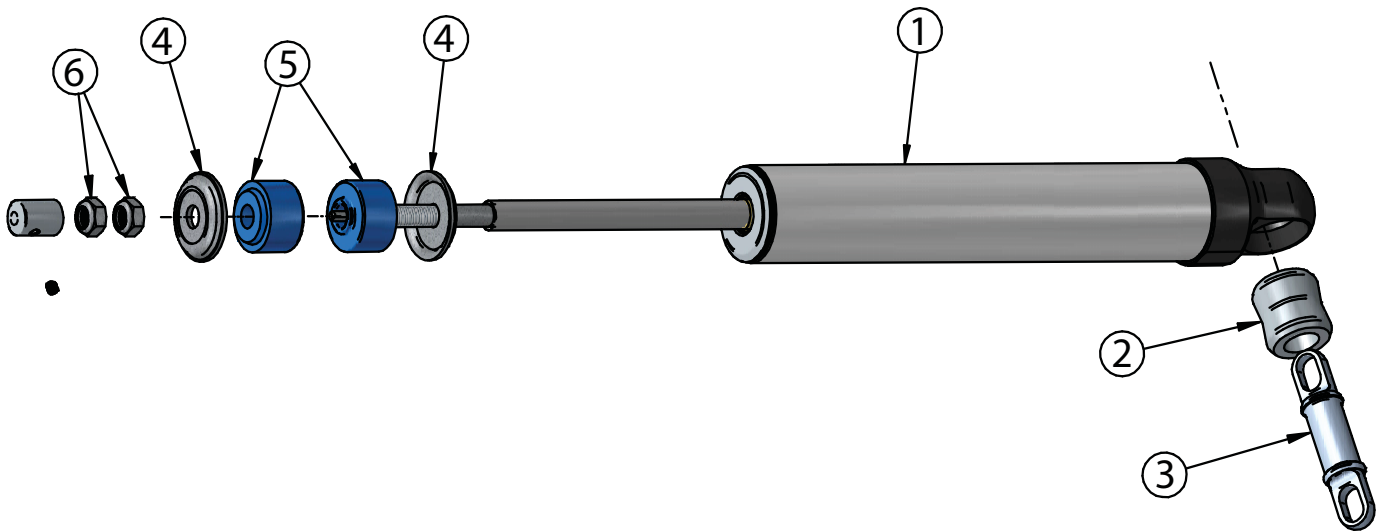



### CoilOver Installation

1.

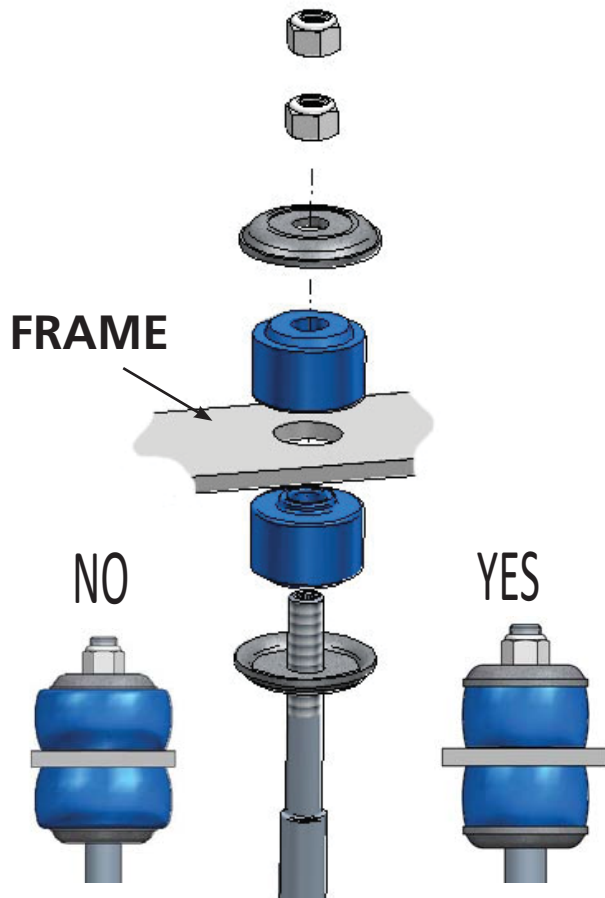

1. With the OEM Shock removed, install the RideTech shock. Install a Bushing Support Washer on to the shock shaft followed by a Shock Stem Bushing. Insert the assembly through the factory shock hole in the frame. With the shock stud sticking through the frame, install a Shock Stem Bushing on to the shock stud followed with a Bushing Support Washer. Install a 3/8"-24 Thin Jam nut onto the threads and tighten. Tighten until the bushing is tight, but not to the point to where the bushing is bulging past the Support Washer. Install the 2nd 3/8-24 Thin Jam nut and tighten it against the first nut.

2.

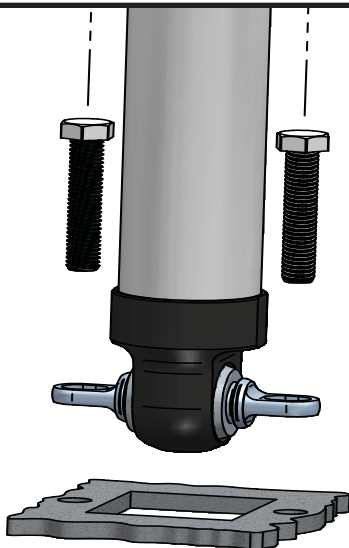

2. Attach the Trunnion to the OEM Control arm using the OEM hardware. It may be necessary to rotate the Trunnion to get it in the correct position. This can be done by sticking a screwdriver in one of the slots and spinning the trunnion in the shock bushing.



### 1998-2013 C5/C6 HQ Rear Smooth Body Shocks

#### Major Components .....In the box

Item #	Part #	Description	QTY
1	986-10-038	3.85" Stroke HQ Series Shock	2
2	70011489	Lower Shock Mount (Attached to Shock)	2
3	90002128	Upper Shock Mount - Driver	1
3	90002129	Upper Shock Mount - Passenger (Not Shown)	1
4	70011138	3/4" ID Shock Bushing	2
5	90002106	1/2" ID Shock Sleeve	2
6	99371040	3/8"-24 x 5/8" S.S. Button Head (Installed in shock)	2
7	99501032	1/2"-13 x 2 1/2" S.S. Hex Bolt	2
8	99502011	1/2"-13 S.S. Nylok Locknut	2
	008-03-012	Bumpstop (installed on shock shaft)	2

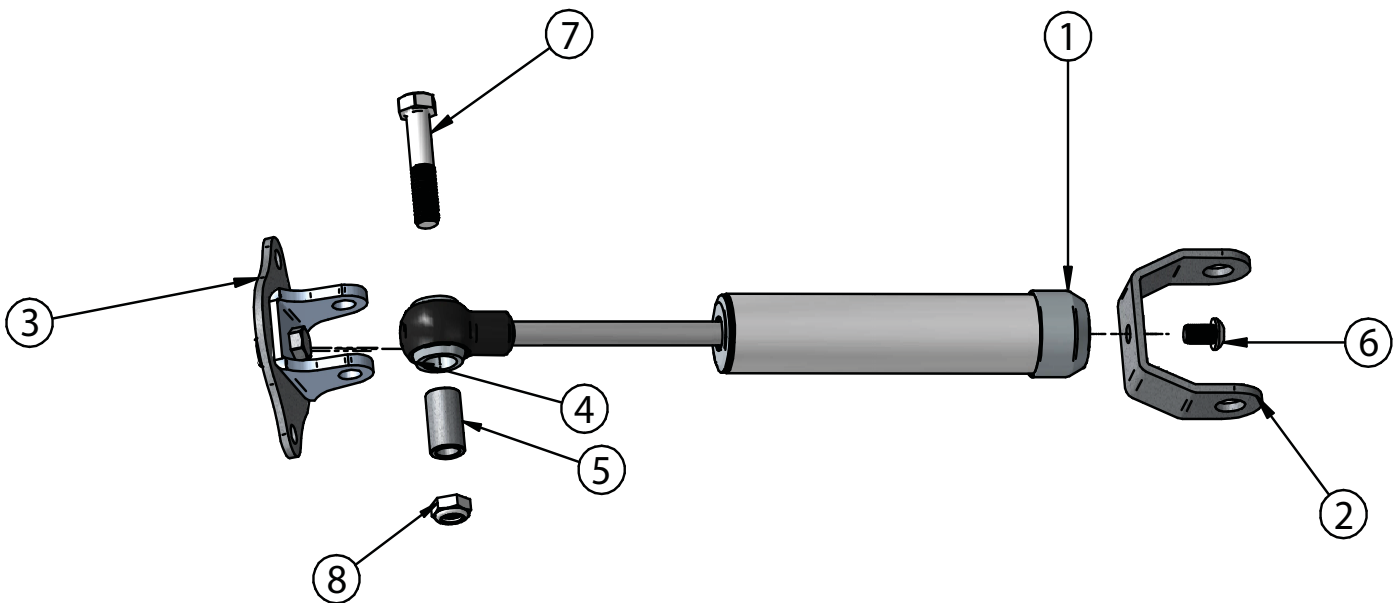



### CoilOver Assembly

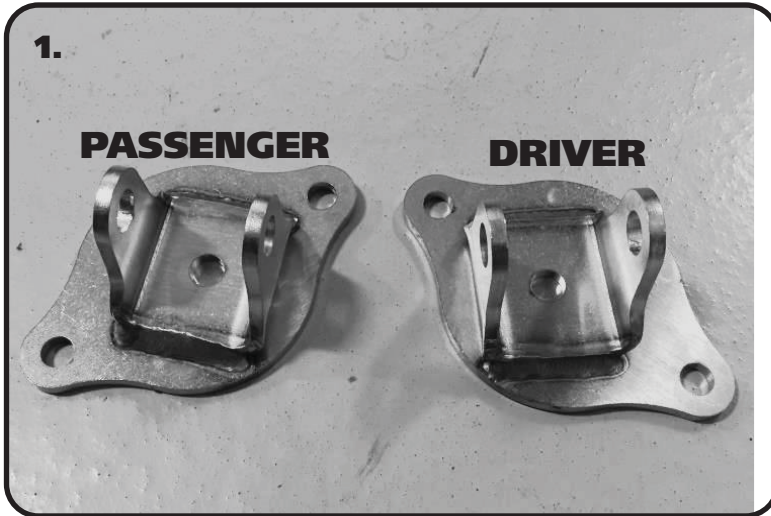

1. Start by removing the OEM shock. With the shock removed start installing the New HQ Series shocks. The Upper Mount will be replaced with mounts included in the Shock Kit. The new Upper Mounts will offset the Shock to the front of the Corvette. When these mounts are installed correctly, the Upper Mounting Bolt will be PARALLEL with the Lower Mounting Bolt.

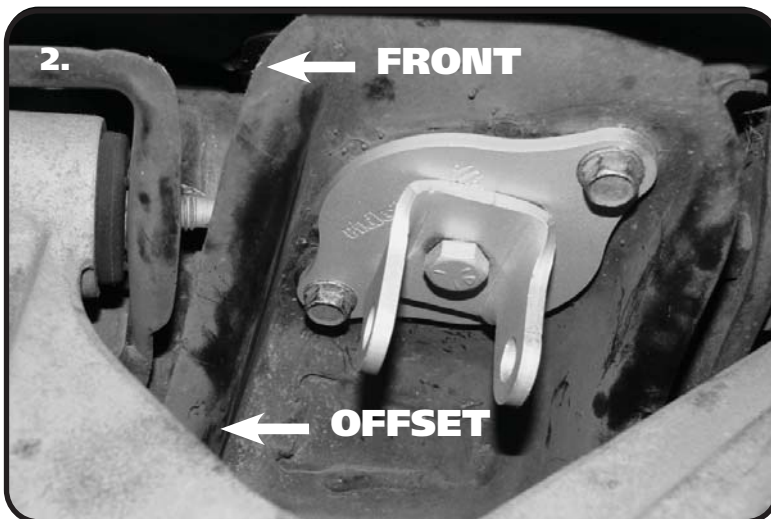

2. Install the upper mount into the car using the factory hardware. The Mount will have the top of the Shock OFFSET TO THE FRONT OF THE CAR.

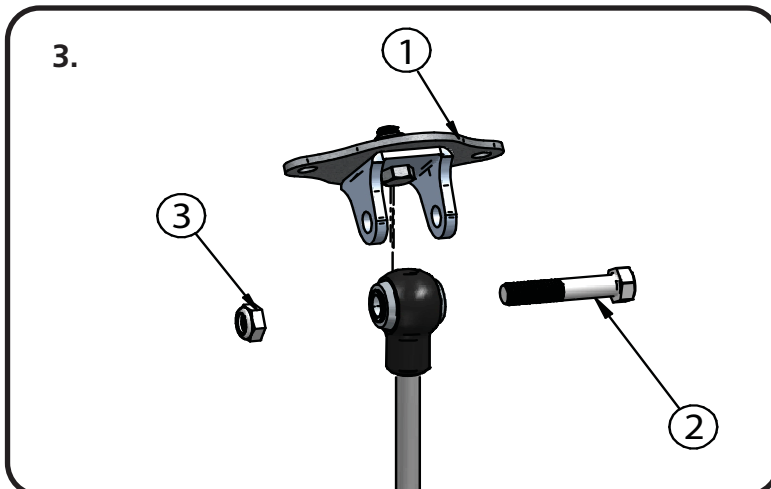

3. With the upper mount installed insert the Shock assembly into the upper shock mount(1). Align the holes in the bracket with the hole in the Shock sleeve and insert the 1/2" Bolt(2). With the Bolt insert install a 1/2" Nylok Nut(3) and tighten. With the upper Shock installed, attach the lower mount to the OEM mount on the Control arm and attach with the OEM hardware.



### Shock Adjustment

#### Shock adjustment 101- Single Adjustable

##### Rebound Adjustment:

How to adjust your new shocks.

The rebound adjustment knob is located on the top of the shock absorber protruding from the eyelet or stud top. You must first begin at the ZERO setting, then set the shock to a street setting of 12.



-Begin with the shocks adjusted to the ZERO rebound position (full stiff). Do this by rotating the rebound adjuster knob clockwise until it stops.

-Now turn the rebound adjuster knob counter clock wise 12 clicks. This sets the shock at 12. (settings 21-24 are typically too soft for street use).

##### Take the vehicle for a test drive.

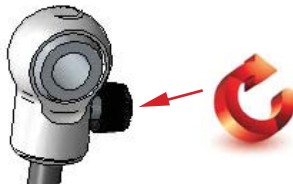

-if you are satisfied with the ride quality, do not do anything, you are set!

-if the ride quality is too soft increase the damping effect by rotating the rebound knob clock wise 3 clicks.

##### Take the vehicle for another test drive.

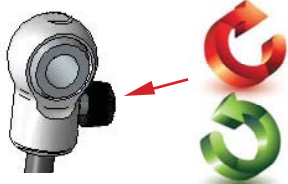

-if the vehicle is too soft increase the damping effect by rotating the rebound knob clock wise 3 additional clicks.

-If the vehicle is too stiff rotate the rebound adjustment knob counter clock wise 2 clicks and you are set!

Take the vehicle for another test drive and repeat the above steps until the ride quality is satisfactory.

##### Note:

**One end of the vehicle will likely reach the desired setting before the other end. If this happens stop adjusting the satisfied end and keep adjusting the unsatisfied end until the overall ride quality is satisfactory.**

### STILL HAVE QUESTIONS?

#### Tech line hours

Monday - Friday

8AM - 6PM (EST) ..... 812-482-2932