

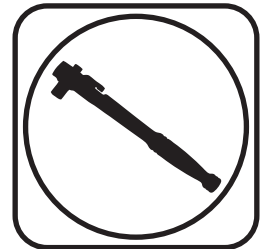

### Part # 1151611 - 1998-2013 C5/C6 TQ Rear CoilOvers

#### Recommended Tools

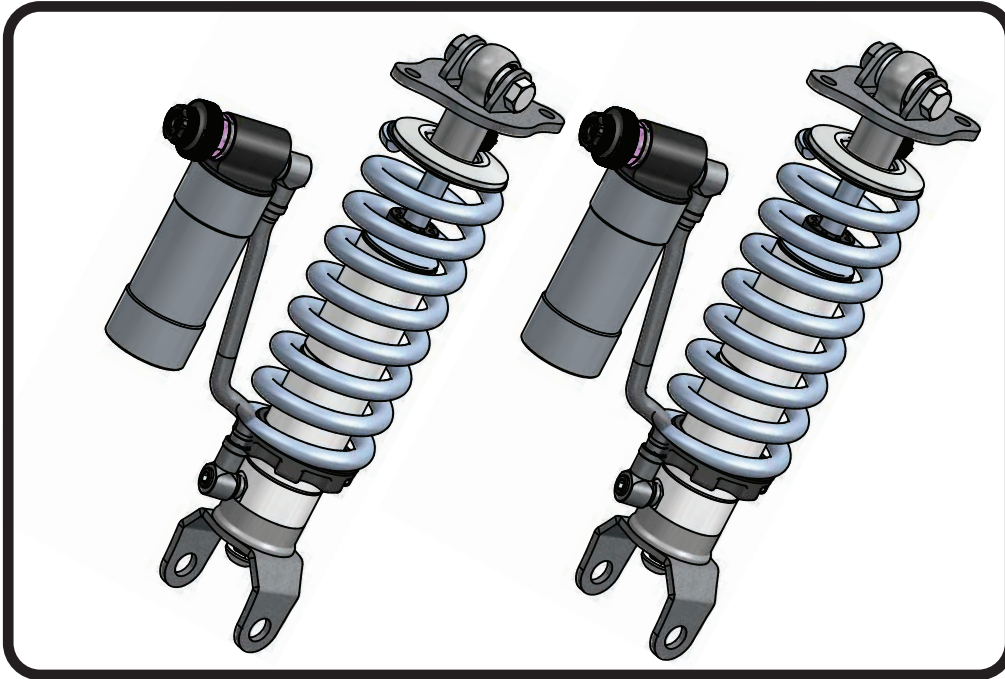

## 1998-2013 C5/C6 TQ Series Rear CoilOvers Installation Instructions

#### Table of contents

Page 2.....	Included components
Page 3.....	Hardware List and Getting Started
Page 4.....	CoilOver Assembly and Installation
Page 5.....	Upper Mount Assembly and Installation
Page 6.....	CoilSpring and Shock Adjustment
Page 7&8.....	Shock Adjustment





### Major Components .....In the box

Item #	Part #	Description	QTY
1	24639999	3.6" Stroke TQ Series Shock	2
2	70011446	Lower Shock Mount (Attached to Shock)	2
3	90002397	Adapter Puck (Attached to Shock)	2
4	90002636	Adapter Ring (Attached to Shock)	2
5	70010828	Delrin Spring Washer	4
6	803-00-199(kit)	Lower Spring Adjuster Nut (803-00-199 kit)	2
7	803-00-199(kit)	Adjuster Nut Locking Screw (803-00-199 kit)	2
8	803-00-199(kit)	Upper CoilSpring Retaining Plate (803-00-199 kit)	2
9	803-00-199(kit)	CoilSpring Plate Retaining Ring (803-00-199 kit)	2
10	90002025	2.7" Upper Shock Eyelet	2
11	90002043	Upper Eyelet Bearing Spacers	2
12	90002584	Upper Shock Mount Assembly - Driver	1
12	90002585	Upper Shock Mount Assembly - Passenger	1
	90001994	5/8" ID Bearing (installed in shock eyelet)	2
	90001995	Bearing Snap Ring (installed in shock eyelet)	4
	90002221	Reservoir Clamps (Not Shown)	4
	99050000	Reservoir Socket Head Cap Screws (Not Shown)	12
	59070600	7" 600lb CoilSpring	2

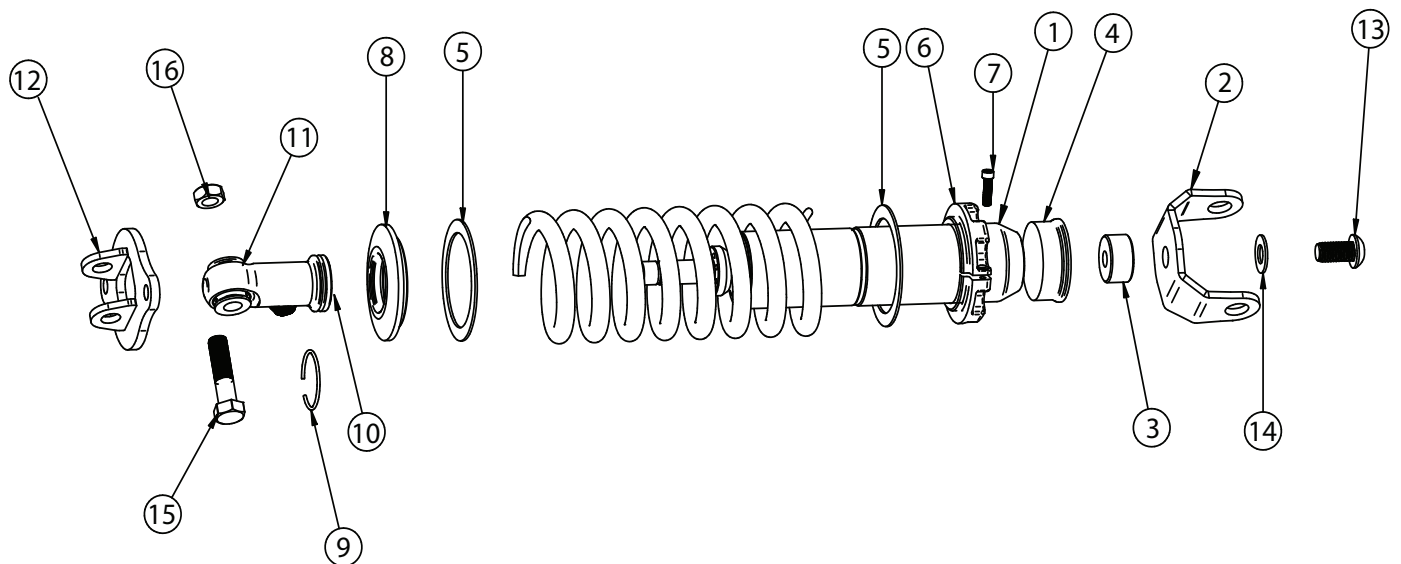



### Hardware List ....In the box

QTY	Part Number	Description	
2	99501031	1/2:-13 x 3/4" Button Head	Lower Shock Mount to Shock (13)
2	99503006	1/2" SAE Flatwasher	Lower Shock Mount to Shock (14)
2	99501041	1/2"-20 x 2" Hex Bolt	Upper Shock To Mount (15)
2	99502016	1/2"-20 Nylok Nut	Upper Shock to Mount (16)

### Getting Started.....

Congratulations on your purchase of the Ridetech C5/C6 CoilOver System. This system has been designed to give your Corvette excellent handling along with a lifetime of enjoyment. The CoilOver System provides flexibility that can not be achieved with Leaf Springs. The CoilOver System will give you the flexibility of adjusting your ride height along with numerous spring options to dial in your ride quality to your personal preference.

#### **This CoilOver System is Designed to replace the factory Shock and Leaf Springs.**

1. The rear OEM Shocks and Leaf Spring will need to be removed from the rear of the car.
2. Raise the vehicle and support it by the frame or rear crossmember allowing the suspension to hang freely.
3. Remove the shocks from both sides retaining the hardware.
4. Relieve all the tension on the springs. Place a 21 mm wrench on the top nut on one of the spring adjuster bolts, and then use an 18mm socket wrench on the head of the bolt to loosen it. Do this step on both sides.
5. With the tension relieved from the spring, remove the (4) bolts that hold the spring retaining straps and remove the spring from the car
6. With the Shocks and Leaf Springs removed you are ready to start assembling the CoilOvers and install them in your Corvette.

To get Started refer to the page 4 on how to assemble the CoilOver



### CoilOver Assembly...



1

First, using the supplied lower adjuster nut (803-00-199) thread the nut onto the shock from the bottom side as seen in figure 1. Remove the plastic pellet that is in the split of the adjuster nut.



2

Next, install a delrin washer then coil spring over the top of the shock as seen in figure 2.

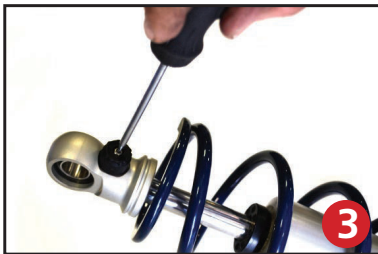

3

Before the upper spring mount can be installed screw the adjuster knob on the upper eye mount to the firmest setting (clockwise) as seen in figure 3. Then remove the Knob by holding it while removing the center screw.



4

Once the knob is removed slide a Delrin washer over the eyelet. Next, slide the upper spring mount (803-00-199) over eyelet as seen in figure 4.



5

Install upper spring mount retainer clip (803-00-199) into the groove on the upper eyelet as seen in figure 5. Then, reinstall adjuster to complete assembly.

**Install the locking screw in the adjuster nut before setting spring preload, but DO NOT tighten until the spring preload has been set.**

**NOTE:** Remember to adjust the shock valving before driving, the shock is currently set to full stiff.

### CoilOver Installation

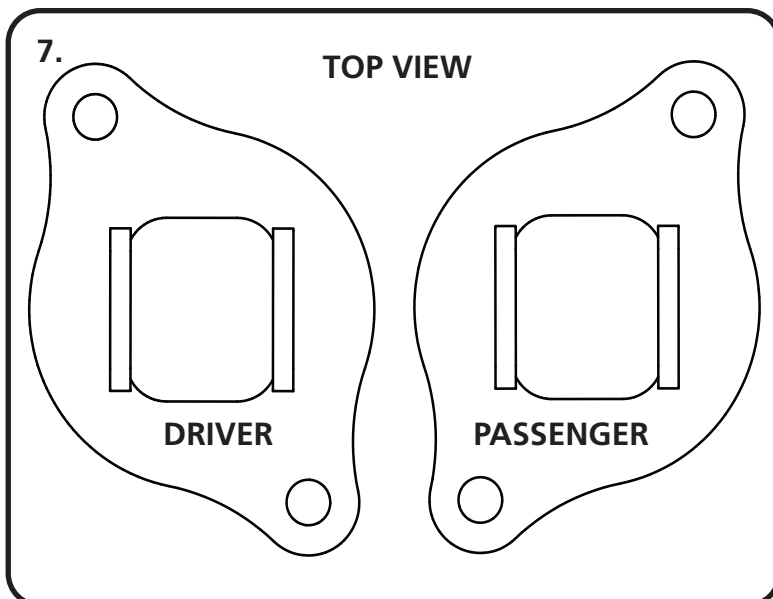

7. New Upper Mounts are included to replace the OEM mounts. The Upper Mount will be replaced with mounts included in the Shock Kit. When these mounts are installed correctly, the Upper Mounting Bolt will be PARALLEL with the Lower Mounting Bolt.



### Upper Mount Fitting and Installation



8. Insert the 1/2" x 2" Bolt through the holes in the tabs of the Upper Mount. Test fit the Upper Mount to see if any clearancing is necessary. The Mount needs to sit tight against the OEM shock mount with the mounting holes aligned. You may have to clearance the hole for the bolt to fit through it.



9. Clearance the hole if the Mount doesn't sit correctly.

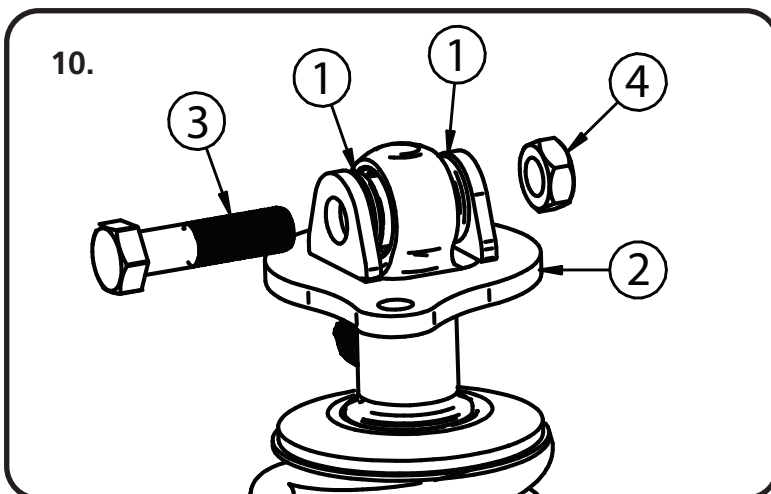

10. With the CoilOver assembled insert the upper spacers(1) into the upper shock bearings. With the spacers installed insert the CoilOver assembly into the upper shock mount(2). Align the holes in the bracket with the hole in the Shock spacers and insert the 1/2" Bolt(3) and secure with the 1/2" Nylok Nut(4). Once the Mounts are assembled on the CoilOvers, install the assembly into the car making sure they are on the correct sides. The attaching bolt should run front parallel with the lower shock mount.



### Attaching Lower

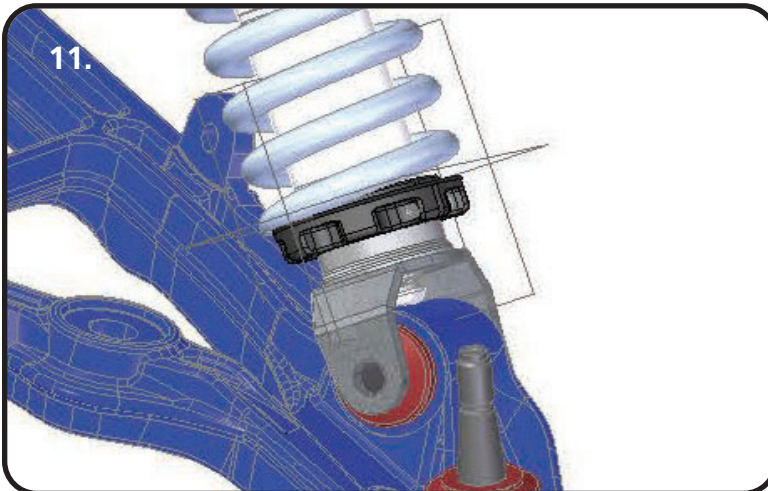

**11.** Attach the lower CoilOver mount to the OEM Shock Mount on the Lower Control Arm using the factory hardware. It may be necessary to raise the lower control arm up to align the CoilOver with the OEM Mount. Tighten the lower Coilspring Adjusting nut until the Coilspring is sitting snugly on the CoilOver. Using the Spanner wrench add another 1/2" of preload in the spring by threading the adjuster nut up the Shock Body. Be sure that the locking screw is lightly tightened in the adjuster nut. Once you have preloaded tighten the locking screw. It may be necessary to add more preload, this will be determined once the car is setting on the ground.

### CoilSpring Adjusting

#### Ride Height

We have designed most cars to have a ride height of about 1 1/2" lower than factory. To achieve the best ride quality & handling, the shock absorber needs to be at 40-60% overall travel when the car is at ride height. This will ensure that the shock will not bottom out or top out over even the largest bumps. Measuring the shock can be difficult, especially on some front suspensions. Measuring overall wheel travel is just as effective and can be much easier. Most cars will have 4-6" of overall wheel travel. One easy way to determine where you are at in wheel travel is to take a measurement from the fender lip (center of the wheel) to the ground. Then lift the car by the frame until the wheel is just touching the ground, re-measure. This will indicate how far you are from full extension of the shock. A minimum of 1.5" of extension travel (at the wheel) is needed to ensure that the shock does not top out. If you are more than 3" from full extension of the shock then you are in danger of bottoming out the shock absorber.

#### Adjusting Spring Height

When assembling the CoilOver, screw the spring retainer tight up to the spring (0 preload). After entire weight of car is on the wheels, jounce the suspension and roll the car forward and backward to alleviate suspension bind.

- If the car is too high w/ 0 preload then a smaller rate spring is required. Although threading the spring retainer down would lower the car, this could allow the spring to fall out of its seat when lifting the car by the frame.
- If the car is too low w/ 0 preload, then preload can then be added by threading the spring retainer up to achieve ride height. On 2.6" - 4" stroke shocks, up to 1.5" of preload is acceptable. On 5-7" stroke shocks, up to 2.5" of preload is acceptable. If more preload is needed to achieve ride height a stiffer spring rate is required. Too much preload may lead to coil bind, causing ride quality to suffer.



### Shock Adjustment

#### Shock Adjustment 101- Single Adjustable

##### Rebound Adjustment:

How to adjust your new shocks.

The rebound adjustment knob is located on the top of the shock absorber protruding from the eyelet.

You must first begin at the ZERO setting, then set the shock to a soft setting of 20.



-Begin with the shocks adjusted to the ZERO rebound position (full stiff). Do this by rotating the rebound adjuster knob clockwise until it stops.



-Now turn the rebound adjuster knob counter clock wise 20 clicks. This sets the shock at 20. (settings 21-24 are typically too soft for street use).

##### Take the vehicle for a test drive.



-if you are satisfied with the ride quality, do not do anything, you are set!



-if the ride quality is too soft increase the damping effect by rotating the rebound knob clock wise 3 clicks.

##### Take the vehicle for another test drive.



-if the vehicle is too soft increase the damping effect by rotating the rebound knob clock wise 3 additional clicks.



-If the vehicle is too stiff rotate the rebound adjustment knob counter clock wise 2 clicks and you are set!

Take the vehicle for another test drive and repeat the above steps until the ride quality is satisfactory.

##### Note:

**One end of the vehicle will likely reach the desired setting before the other end. If this happens stop adjusting the satisfied end and keep adjusting the unsatisfied end until the overall ride quality is satisfactory.**



## Shock Adjustment

### Shock Adjustment 101- Triple Adjustable

#### Triple Adjustable:

#### Step One: High Speed Compression



- High speed compression adjustments are used in both street driving and track tuning.
- Begin with the shocks adjusted to the ZERO high speed compression position (full stiff). Do this by rotating the high speed compression adjuster (large knob) clockwise until it stops.
- Now turn the high speed compression adjuster knob counter clock wise 20 clicks. This sets the shock at 20. (settings 21-24 are typically too soft for street use. For typical street driving the high speed compression adjuster will remain at setting 20.

#### Step Two: Low Speed Compression

Low speed compression adjustment is what is typically felt during street driving.



- Begin with the shocks adjusted to the ZERO low speed compression position (full stiff). Do this by rotating the low speed compression adjuster (small knob) clockwise until it stops.
- Now turn the low speed compression adjuster knob counter clock wise 20 clicks. This sets the shock at 20. (settings 21-24 are typically too soft for street use). Take the vehicle for a test drive.
- if you are satisfied with the ride quality, do not do anything, you are set!
- if the ride quality is too soft increase the damping effect by rotating the low speed compression knob clock wise 3 clicks.

#### Take the vehicle for another test drive.



- if the vehicle is too soft increase the damping effect by rotating the low speed compression knob clock wise 3 additional clicks.
- If the vehicle is too stiff rotate the low speed compression adjustment knob counter clock wise 2 clicks and you are set!

Take the vehicle for another test drive and repeat the above steps until the ride quality is satisfactory.

#### Step 3:

Adjust rebound according to Single Adjustable instructions.

#### **Note:**

**One end of the vehicle will likely reach the desired setting before the other end. If this happens stop adjusting the satisfied end and keep adjusting the unsatisfied end until the overall ride quality is satisfactory.**