

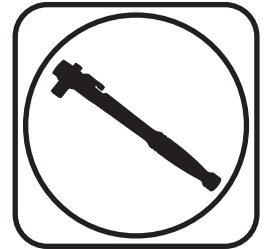

**Part # 11519501 - 06-13 C6 Z06 Corvette Delrin Bushing Kit**



Recommended Tools



## 2006-2013 C6 Z06 Delrin Control Arm Bushing Kit Installation Instructions

### Table of contents

- Page 2..... Included components
- Page 3..... Bushing Dimensions
- Page 4..... Disassembly and Front Upper
- Page 5..... Front Upper Bushing Installation
- Page 6..... Front Lower
- Page 7..... The Finish





### Included Components ....In the box

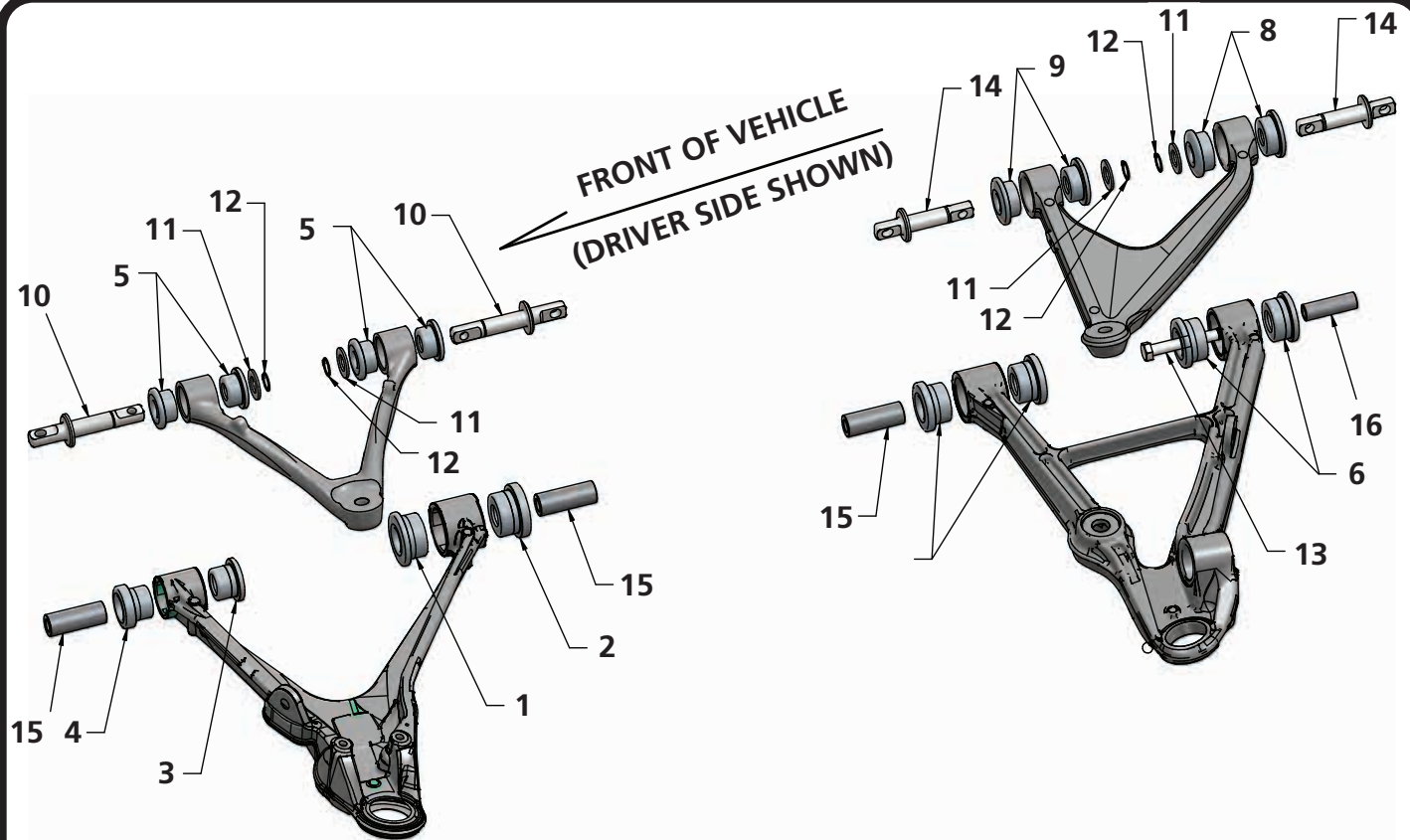

Item #	Part #	Description	QTY
1	70012110	Front Lower Control Arm Large Inner Bushing	2
2	70012111	Front Lower Control Arm Large Outer Bushing	2
3	70012112	Front Lower Control Arm Small Inner Bushing	2
4	70012113	Front Lower Control Arm Small Outer Bushing	2
5	70012114	Front Upper Control Arm Bushing	8
6	70012115	Rear Lower Control Arm Bushing; Large	4
7	70012116	Rear Lower Control Arm Bushing; Small	4
8	70012197	Rear Upper Control Arm Bushing; Large	4
9	70012198	Rear Upper Control Arm Bushing; Small	4
10	90002125	Front Upper Trunnion <b>(Long)</b>	4
11	99753006	3/4" I.D. Washer	8
12	90001634	3/4" Snap Ring	8
13	99501034	1/2"-13 x 4 1/2" Hex Bolt, Flat Washer, & Nylok Nut	2
14	90002200	Rear Upper Trunnion <b>(Short)</b>	4
15	90002544	Inner Sleeve; 1.00" OD x .562" ID x 2.717" OAL	6
16	90002545	Inner Sleeve; 1.00" OD x .500" ID x 2.480" OAL	2



### Bushing Dimensions

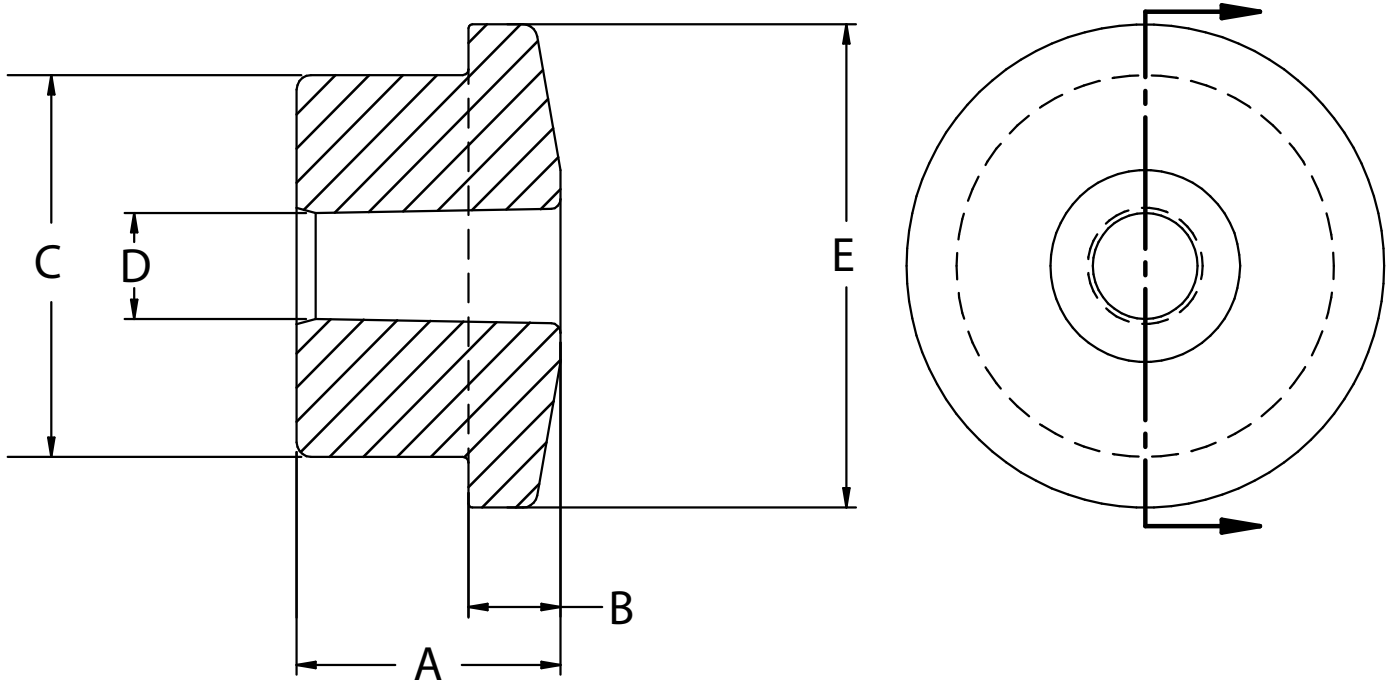

### Bushing Dimensions

Item #	Part #	A	B	C	D	E
1	70012110	1.200	.295	1.975	.995	2.450
2	70012111	1.390	.490	1.975	.995	2.450
3	70012112	1.230	.295	1.454	.995	1.950
4	70012113	1.430	.495	1.454	.995	1.950
5	70012114	.900	.250	1.408	.745	1.850
6	70012115	1.140	.320	1.885	.995	2.240
7	70012116	1.260	.385	1.767	.995	2.240
8	70012197	.895	.295	1.737	.745	2.140
9	70012198	.900	.295	1.580	.745	2.140

**NOTE:** These are nominal dimensions. Due to manufacturing tolerances, these dimensions can vary slightly.

### Inner Sleeve Dimensions

Item #	Part #	OD	ID	Over All Length
15	90002544	1.00"	.562"	2.717"
16	90002545	1.00"	.500"	2.480"



### Disassembly

Congratulations on your purchase of the Ridetech C5/C6 Control Arm Delrin Bushing Kit. This kit has been designed to help improve your Corvette's handling along with providing a lifetime of enjoyment. The Delrin Bushing Kit will improve your Cars handling characteristics by eliminating the deflection at the bushing.

We recommend doing one Control Arm at a time to simplify installation of the bushings.

Raise the vehicle and support it by the frame or rear crossmember, allowing the suspension to hang freely.

With the Wheels and Tires removed, disconnect the Shocks, Springs, and Sway Bar Linkage from the Lower Control Arms, retaining the hardware. Support the Rotor Assembly when removing any of the Control Arms to prevent unnecessary strain on the Brake Lines and ABS Sensor Wires.

With the Rotor and Hub supported, remove the Upper Control Arm by , first removing the balljoint nut and using a balljoint separator to release the balljoint from the Control Arm.

Next, remove the (4) bolts attaching the Trunnion to the car. Mark any shims that may be behind the Trunnion. You will need to put these back in the same location when reinstalling the Control arm.

### Front & Rear Upper Trunnion & Bushing Removal

With the end of the Trunnion clamped in a Bench Vise, use a twisting motion to remove the Trunnion and Bushing assembly from the Control Arm. Do this for both Trunnions.

Once the Bushing Assembly is removed from the arm, prep the bushing opening by cleaning it to remove any debris that may be left in the opening.

Use the Illustration on Page 2 & 3 to determine the parts needed for the Delrin Bushing & Trunnion installation in the upper arms. To do (1) Arm, you will need (4) Upper Control Arm Bushings[5]Front, [8 & 9]Rear. You will also need (2) Trunnions[10 Long]Front, [13 Short]Rear, (2) 3/4" ID Washers[11], and (2) Snap Rings[12].



### Front Upper Bushing Installation

10.

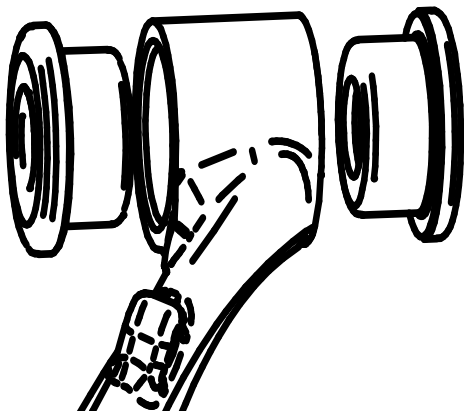

**10.** Press a set of bushings into each opening of the upper control arm. A bench vise can be used to do this.

Note: Front Upper Uses all the same bushings

11.

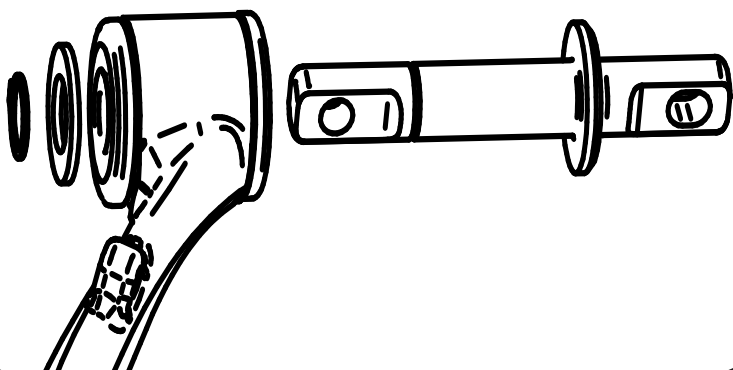

**11.** Install a Trunnion into each set of Bushings installed in the Control Arm. The Trunnions are inserted with the Shoulder to the outside of the Control Arm. Install a 3/4" Washer followed by a Snap Ring on each Trunnion.

12.



**12.** Reinstall the Control Arm on the car with any shims back into their previous location. Tighten all Fasteners.

**Control Arm Mounting Bolts Torque Spec:  
48 ftlbs**

Repeat on other side.



### Front Lower

13.



13. With the upper reattached, it is time to do the Lower Control Arm. Ridetech sells tool 85000006 to aid in removal of the bushings. The Tool is 2-sided with a large opening for the Lower Bushings and the opposite side being smaller for the Rear Upper Bushings. It comes with a Mandrel to insert into the center sleeve for pushing the Bushings out of the Control Arm.

14.



14. Before removing the Lower Control Arms, use a Marker or something similar to mark the Lower Control Arm Eccentrics. The marks will get the Alignment close, but Ridetech recommends getting the alignment checked after the install is completed.

15.

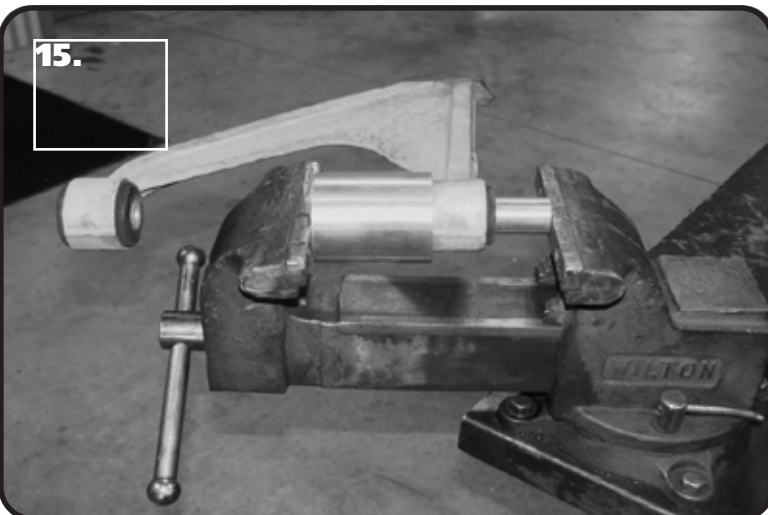

15. Remove the Lower Control Arm. Using the Ridetech tool (with large side over bushing) and a Bench Vise, push out the original Bushings. Clean out the opening of any debris that may have been left behind.



### Finishing

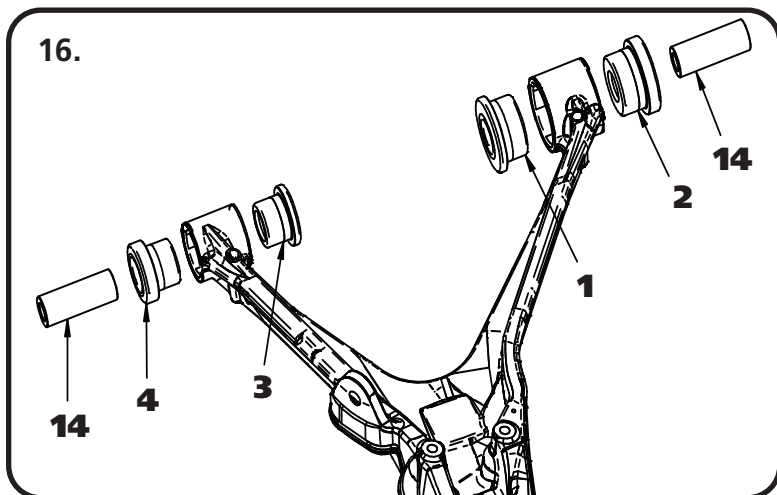

**16.** Using the Diagrams on Page 2 & 3, Insert the correct Bushings in the correct locations using a Bench Vise to push them in. Push the Bushings in followed by the correct Inner Sleeve. The Front Lower uses Bushing 1, 2, 3, 4, and Inner Sleeve 14

Reinstall Arm and repeat for other side. Align the marks that were put on the Eccentric in Step 14 and tighten the Hardware.

**17.** Repeat Steps 13-16 on the remainder of the Control Arms and Bushings using the Diagrams on Page 2 & 3 for Bushing Location. Install 1/2" x 4 1/2" Bolt, washers and Nylok Nut in the Rear Bushing of the Rear Lower Control Arm. **Be sure to mark the Eccentrics.** The simplest way to do the install is to do one arm at a time.

#### Torque Specs:

Front Lower Control Arm Cam Nuts	-	125 ftlbs
Rear Lower Control Arm, Front Cam Nut	-	107 ftlbs
Rear Lower Control Arm, Rear Cam Nut	-	70 ftlbs

**18.** Reattach the Shocks, Springs, and Sway Bar Linkage.

**19.** After installing all Bushings, it is recommended to get the Corvette Alignment checked.