

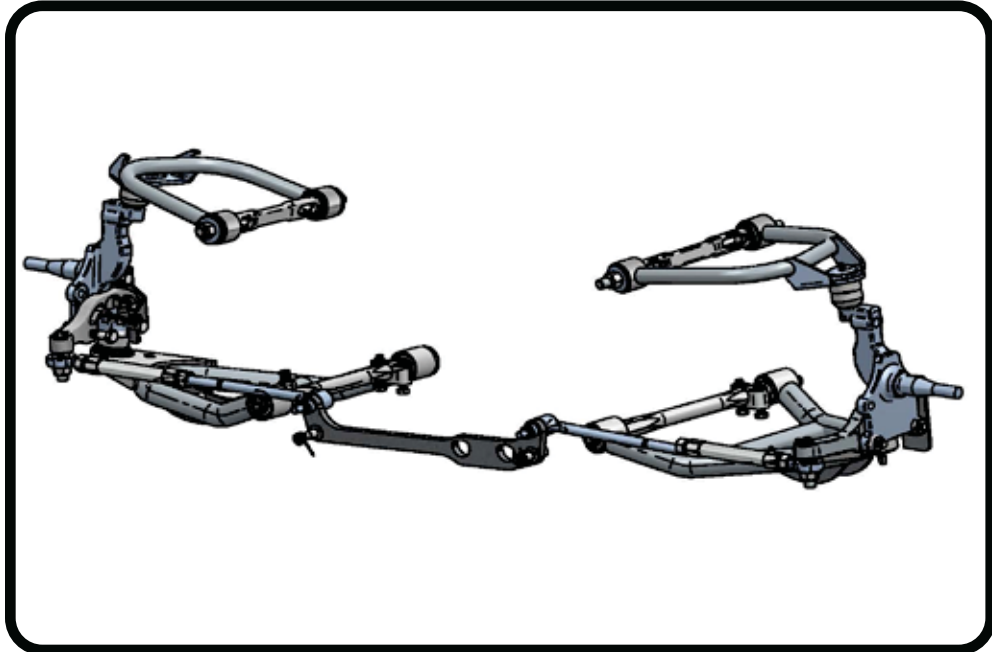

Part # 11539599

1963-1967/1968-1981 C2/C3 Corvette Front TruTurn System



Recommended Tools

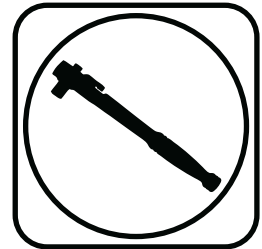

C2/C3 Corvette Front TruTurn System

Installation Instructions

Table of contents

- Page 2..... Included components
- Page 3..... Upper Control Arm Components
- Page 4..... Lower Control Arm Components
- Page 5..... TruTurn Steering Components
- Page 6..... Misc Hardware List and Getting Started
- Page 7..... Installing Lower and Upper Control Arm
- Page 8..... Caster Explained
- Page 9..... Offset Upper Cross Shaft
- Page 10..... Installing Upper Control Arm and Spindle
- Page 11..... Installing TruTurn System
- Page 12..... Tie-Rod Assembly and Installation
- Page 13..... The Finish

The OEM Front Brakes will not work with this kit.
(See Page 6 for details)



Major ComponentsIn the box

Item #	Part #	Description	QTY
1	90002161	Driver Upper Control Arm	1
1	90002162	Passenger Upper Control Arm (Not Shown)	1
2	90002159	Driver Lower Control Arm	1
2	90002160	Passenger Lower Control Arm (Not Shown)	1
3	11009300	Tall Spindle (Driver and Passenger)	1pr
4	90002173	Driver Steering Arm	1
4	90002174	Passenger Steering Arm (Not Shown)	1
5	90003187	Driver Steering Stop	1
5	90003188	Passenger Steering Stop (Not Shown)	1
6	90002170	Draglink Adapter	1
7	90003053	Inner Tie-Rod	2
8	90002652	Tie-Rod Adjuster	2
9	90001582	Heim End (used On Tie-Rod)	2
10	90009931	Outer Tie Rod Stud	2
11	90009932	Steering Arm Tapered Nut	2
12	90009933	Draglink Stud	2
13	90002373	Tie Rod Stud Lock Nut Spacer	2

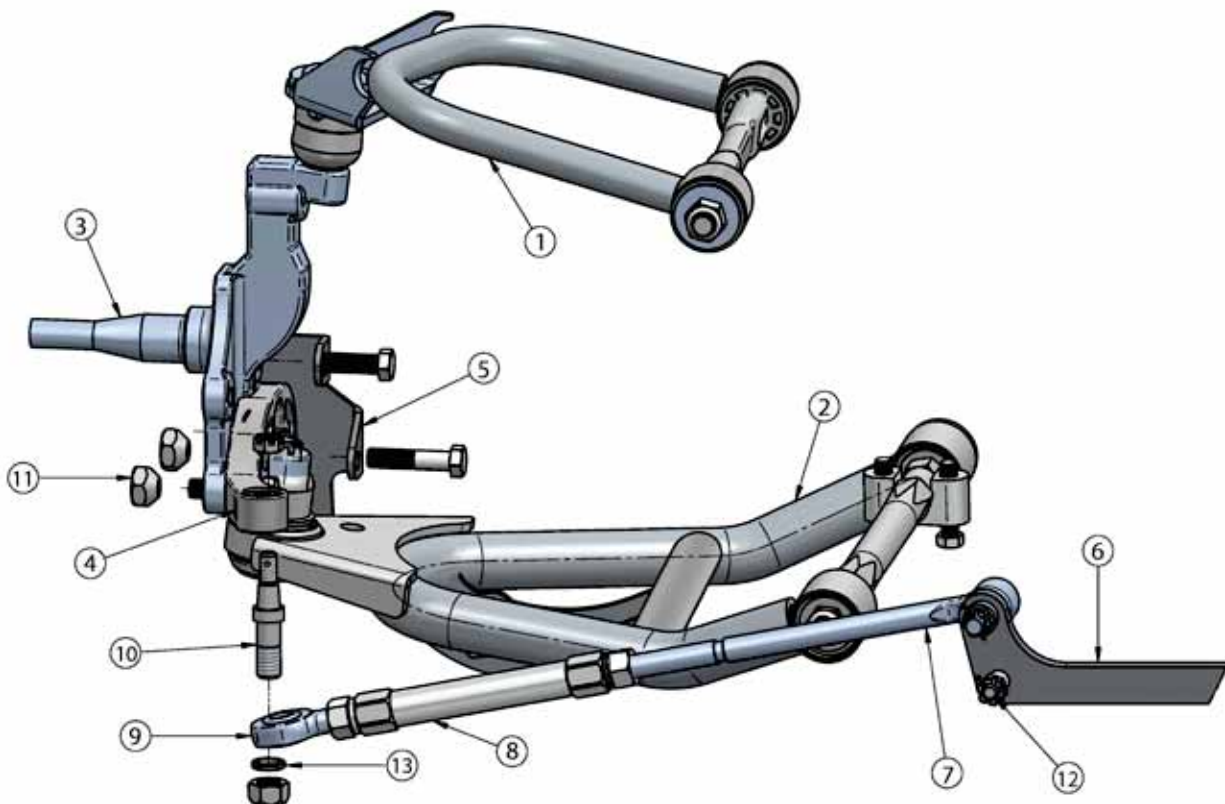



Upper Control Arm ComponentsIn the box

Item #	Part Number	Description	QTY
1	90002161	Driver Upper Control Arm (Shown)	1
1	90002162	Passenger Upper Control Arm	1
2	90000908 Kit	Upper Ball joint Assembly - Proforged # 101-10015	2
3	70010826	Inner Delrin Bushing - No Ledge	2
4	70010759	Outer Delrin Bushing	4
5	90003375	Caster Adjustable Upper Control Arm Shaft	2
6	70011955	Caster Slug	4
7	90002737	T-Washer	4
8	70010827	Inner Delrin Bushing - with Ledge	2
9	99753007	3/4" x 1 3/4" Flat Washer	2
10	99753005	3/4" SAE Flat Washer	2
11	99622005	5/8 - 18 Thin Locknut	4

Driver Side Shown

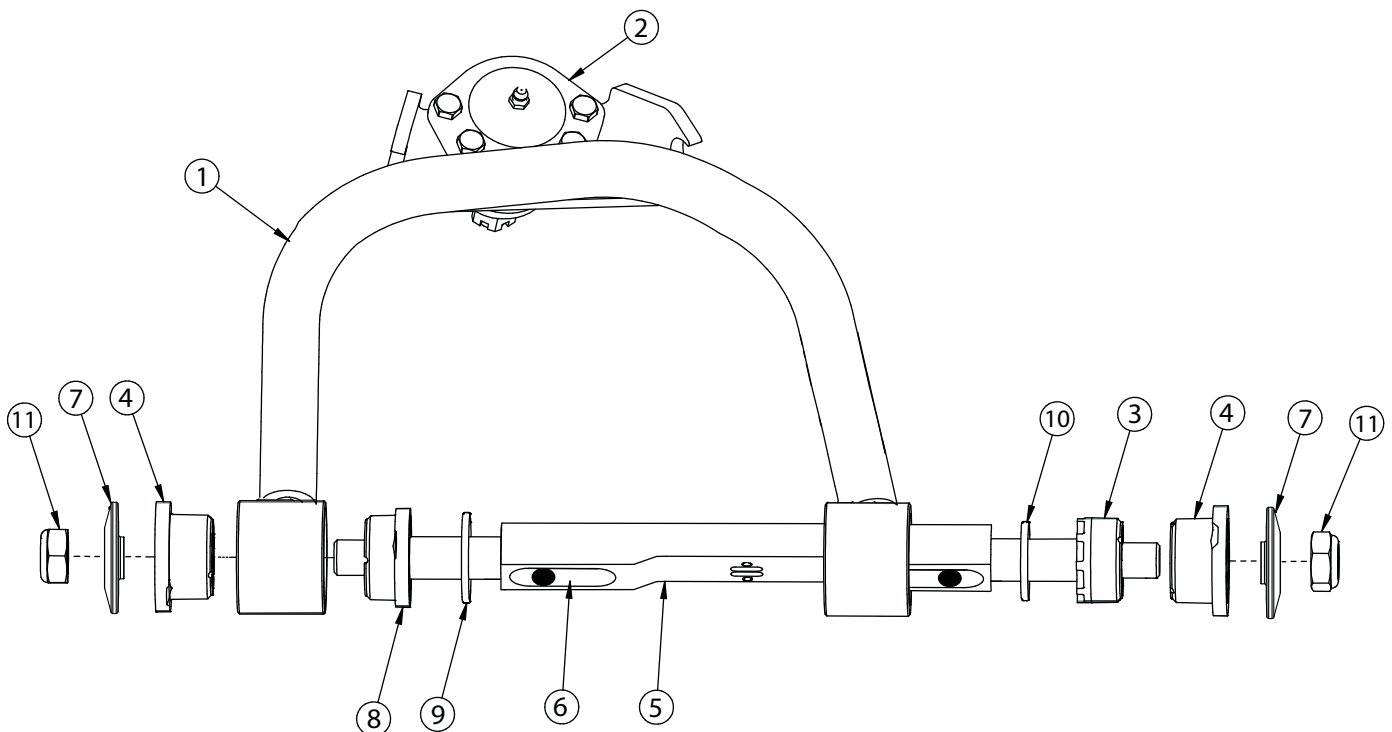

HARDWARE LISTED ON PAGE 6



Lower Control Arm ComponentsIn the box

Item #	Part Number	Description	QTY
1	90002159	Driver Lower Control Arm (Shown)	1
1	90002160	Passenger Lower Control Arm	1
2	90002179	Lower Control Arm Cross Shaft	2
3	90000898	Lower Ball joint Assembly - Proforged # 101-10013	2
4	90000677	Lower Cross Shaft Clamp	2
5	70010827	Delrin Bushing - with 1 3/4" Diameter Ledge	4
6	70010826	Delrin Bushing - no Ledge	2
7	70010759	Delrin Bushing - with 2" Diameter Ledge	2
8	72000257	Outer 1.5" OD Washer	2
9	99622005	5/8"-18 Thin Locknut	4
10	99753005	Flatwasher	4
11	99501005	1/2"-13 x 3 1/2" Hex Bolt	2
12	99502009	1/2"-13 Nylok Nut	2
13	99163001	Outer 2.0" OD Washer	2
	99503014	1/2" SAE Flat Washer (not shown)	4
	90002062	CoilOver Spacers (not shown)	4

Driver Side Shown

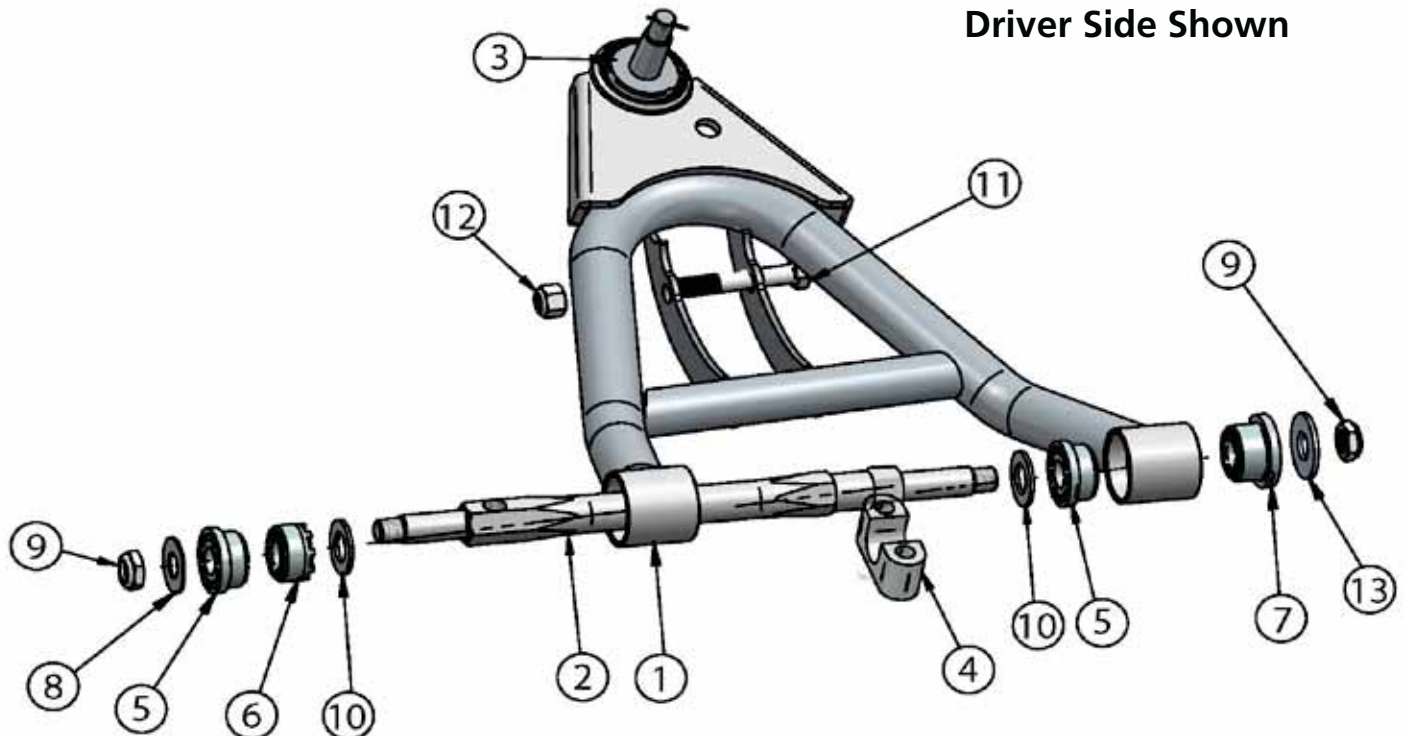



TruTurn Steering ComponentsIn the box

Item #	Part Number	Description	QTY
1	11009300	Ridetech Tall Spindle	1pr.
2	90002173	Driver Steering Arm	1
2	90002174	Passenger Steering Arm (not shown)	1
3	90002170	Draglink Adapter	1
4	90002652	Tie-Rod Adjuster	2
5	90003187	Driver Steering Stop	1
5	90003188	Passenger Steering Stop (not shown)	1
6	90003053	Inner Tie-Rod End	2
7	90009933	Draglink Adapter Stud	2
8	90009931	Outer Tie-Rod Stud	2
9	90001582	Outer Tie-Rod Heim End	2
10	90009932	Tapered Steering Arm Attaching Nut	4
11	99432005	7/16"-20 Castle Nut	4
12	99501008	1/2"-20 x 1 1/2" Hex Bolt	2
13	99502005	1/2"-20 x 2" Hex Bolt	2
14	99501010	1/2"-20 x 2 1/4" Hex Bolt	2
15	99502010	1/2"-20 Mechanical Locking Nut	2
16	99503001	1/2" SAE Flatwasher	4
17	99800002	5/8"-18 Jam Nut	2
18	99800003	5/8"-18 LH Jam Nut	2
19	99622003	5/8" 18 Mechanical Locking Nut	2
20	90002373	Tie-Rod Stud Lock Nut Spacer	2
	90002743	Spindle Nut Kit - 3/4"-20 - Not Shown	1

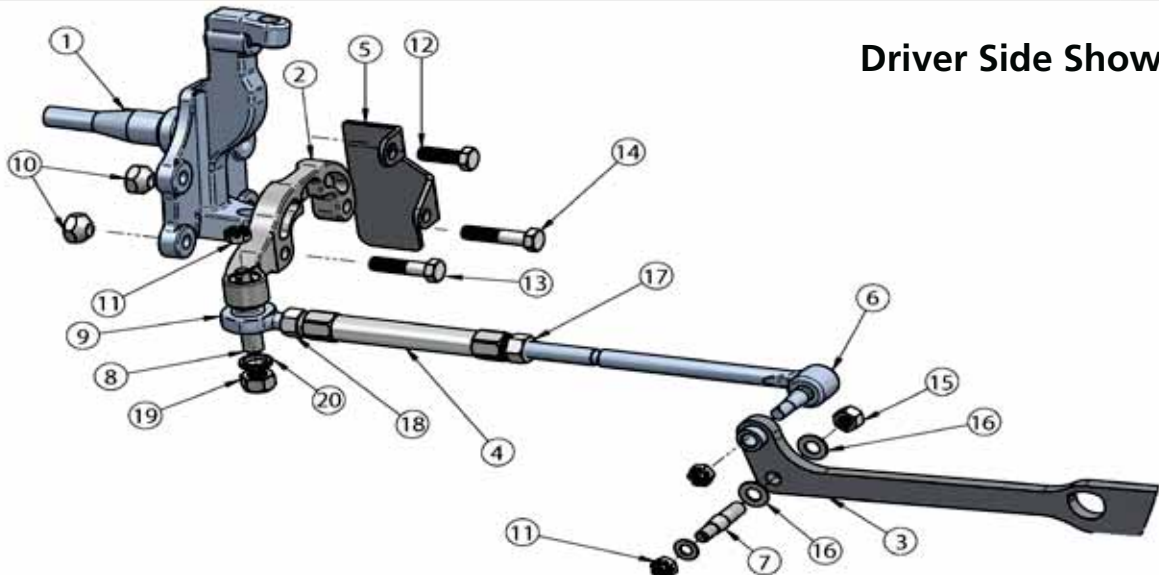

Driver Side Shown



Misc Hardware Not Shown in DiagramsIn the box

QTY	Part Number	Description	
4	99431015	7/16"-20 x 2 1/4" Hex Bolt	Lower Control Arm Clamp to Frame
8	99433005	7/16" Flat Washer	Lower Control Arm Clamp to Frame & Draglink
4	99432007	7/16"-20" Nylok Nut	Lower Control Arm Clamp to Frame
2	99561001	9/16"-18 x 2 1/2" Hex Bolt	Lower Control Arm Cross shaft to Frame
2	99562001	9/16"-18 Nylok Nut	Lower Control Arm Cross shaft to Frame
2	99566003	9/16" SAE Flat Washer	Lower Control Arm Cross shaft to Frame
2	99502003	1/2"-20 Thin Nylok Nut	Steering Stop to Spindle
6	99952002	3/32" Cotter Pin	Tie-Rod and Drag link Adapter Castle Nuts

Getting Started.....

Congratulations on your purchase of the Ridetech TruTurn System. This System have been designed to give your Corvette excellent handling along with a lifetime of enjoyment. Some of the key features of the TruTurn System: Balljoint angles have been optimized for the lowered ride height, Delrin bushings are used to eliminate bushing deflection along with providing free suspension movement through the entire travel. The Geometry has been optimized for excellent handling, driveability and minimal Bumpsteer. The Delrin bushings are made from a material that is self lubricating so no grease zerks are needed. Upper caster adjustable cross shaft is designed to allow you to run maximum caster angles with minimal shims.

Note: These control arms are designed for use with the Ridetech CoilOvers and the MuscleBar swaybar. **The factory shocks and springs or the factory sway bar will not fit these arms.**

Note: The Corvette TruTurn Suspension package uses a GM Spindle used on 67-69 F body, 64-72 A body, and 68-74 X body. Any Brake Kit designed to fit the OEM Disc Brake Spindle of the listed cars will fit the Spindle in your TruTurn System.

Ridetech offers a Front Brake Retention Kit to retain the OEM calipers and rotors for 65-82 Corvettes. This kit will allow you to run 65-82 calipers & rotors on the Ridetech spindle. Part Number for the kit is 11529595

When assembling the Control Arms tighten the cross shaft nuts enough to create drag on the delrin bushings, the arm should still move through its travel by hand.

Installation

1. Remove the entire front suspension from the car leaving the OEM center draglink. Refer to a Factory Service Manual for the proper method. The Control Arms, Spindles, and Tie rods will all be replaced with the TruTurn package.

2. Drill the factory upper shock mounting hole to 3/4". This can be done easily with a Unibit.



Installing Lower & Upper Control Arm

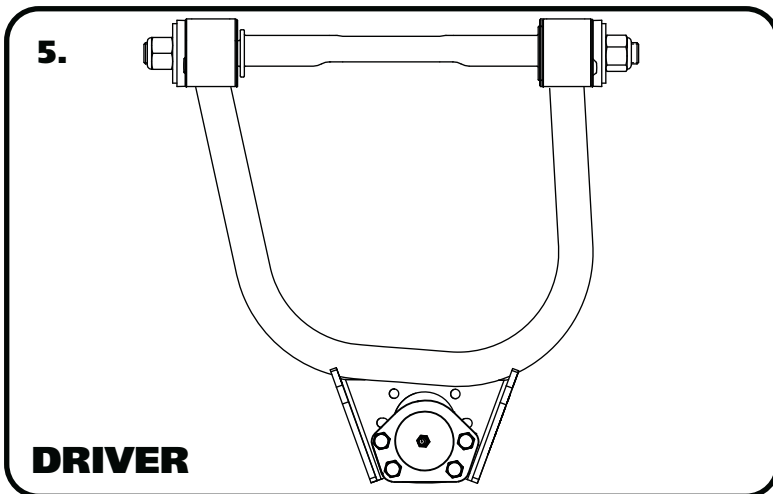
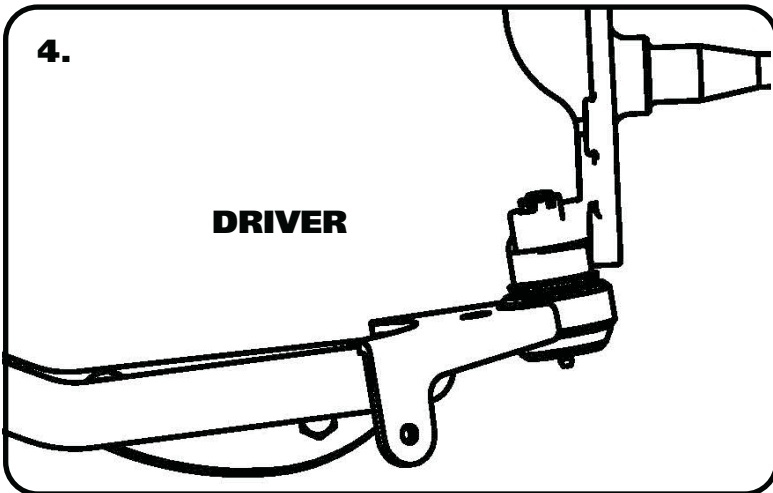

3. Your new lower control arms utilize a clamp for the front 2 mounting holes. The Clamp will slide into the machined groove in the Cross shaft. Attach the Lower Control Arms to the frame using (1) 9/16" x 2 1/2" Hex Bolt, (1) 9/16" Nylok Nut, (2) 7/16"x 2 1/4" Hex Bolt, and (2) 7/16" Flat washer. Tighten the Cross shaft mounting fasteners. Install the Cross shaft Washers and 5/8" Thin Lock Nuts on the Cross shaft. The Front Crossshaft thread uses (1) 2" OD Flat Washer and (1) 5/8" Thin Lock Nut. The rear Cross shaft thread uses (1) 1 1/2" OD washer and (1) 5/8" Thin Lock Nut. Tighten the cross shaft nuts enough to create drag on the Delrin bushings, the arm should still move up and down by hand.

4. The Control Arms are marked "D" for Driver and "P" for Passenger. The Balljoint Pin points up and the Sway bar mount is on the front side of the arm.

Install the CoilOvers at this time. Refer to the CoilOver instructions for Assembly.

5. Install the ball joints into the upper control arm with the hardware supplied with the ball joint. Use the information on the next two pages to help you determine which position will be the best for the alignment you desire. The upper ball joint goes in from the top side of the control arm. The gussets on the ball joint plate point up. Torque the hardware to 15 ftlbs. The Upper Control Arm is attached to the factory mount using factory hardware. The driver side arm is shown in Figure "5". The arrow on the cross shaft points to the front of the car. Pages 8 & 9 have information about caster and the caster slugs.



Caster Explained

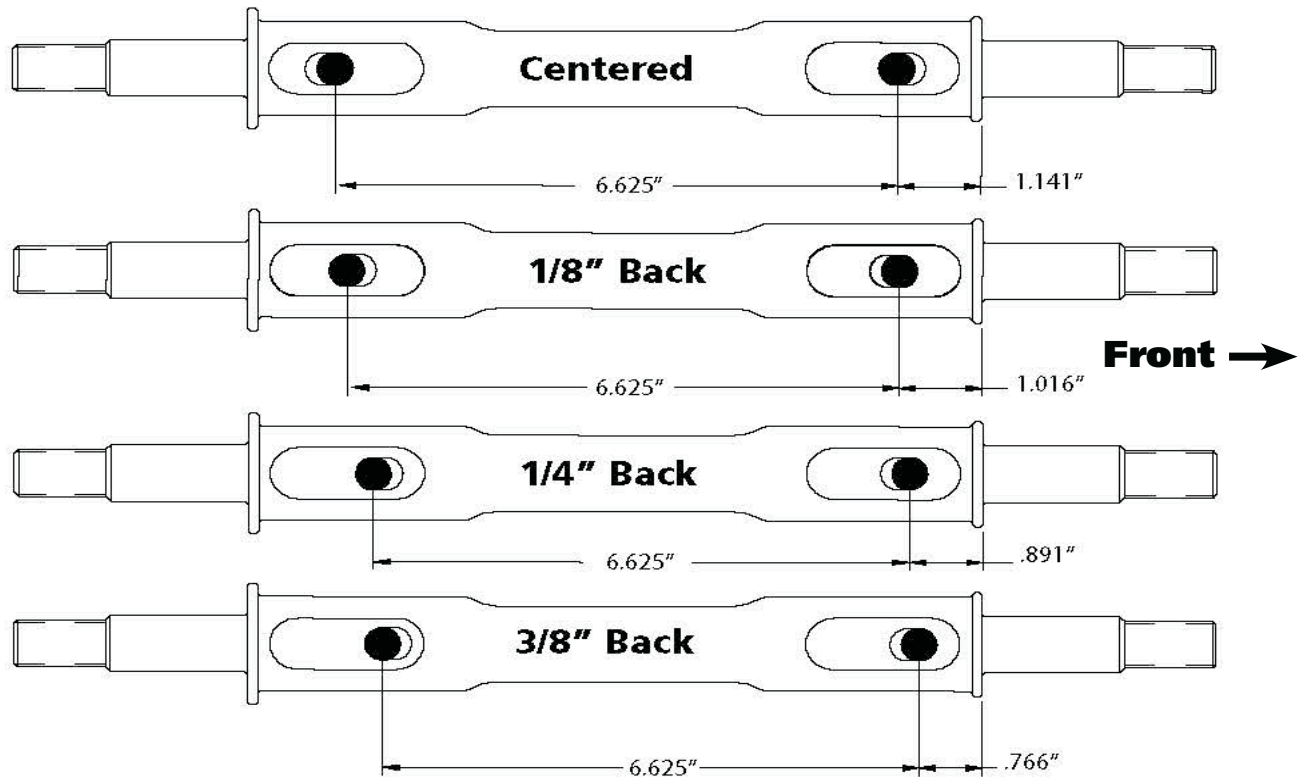

These StrongArms come equipped with a changeable caster slug setup. This allows you to add or remove caster from the front suspension, if desired. The caster slugs that come supplied in the kit are setup to be centered or 1/8" back. The caster slugs allow you to add or remove caster without having to use a stack of shims. If more or less caster is desired, optional slugs can be purchased from Ridetech or your Ridetech dealer.

Caster Explained:

To understand caster you need to picture an imaginary line that runs through the upper balljoint and extends through the lower balljoint. From the side view the imaginary line will tilt forward or backward. The tilting of this imaginary line is defined as caster.

Caster is measured in degrees by using a caster gauge. If the imaginary line described above tilts towards the back of the vehicle at the top, then you have positive caster. If the imaginary line tilts forward then you have negative caster.

Positive caster provides the directional stability in your vehicle. Too much positive caster will make the steering effort difficult. Power steering will allow you to run more positive caster. Negative caster requires less steering effort but will cause the vehicle to wander down the highway



Camber Adjustment

The upper control arms in this kit has 2 separate adjustments to help you get the camber setting you desire for your application. The upper cross shaft is offset and can be mounted in 2 different positions. Also, the upper ball joint can be bolted to the control arm in 2 different positions. The combination of the 2 will allow you to get the alignment you desire with a minimal amount of shims.

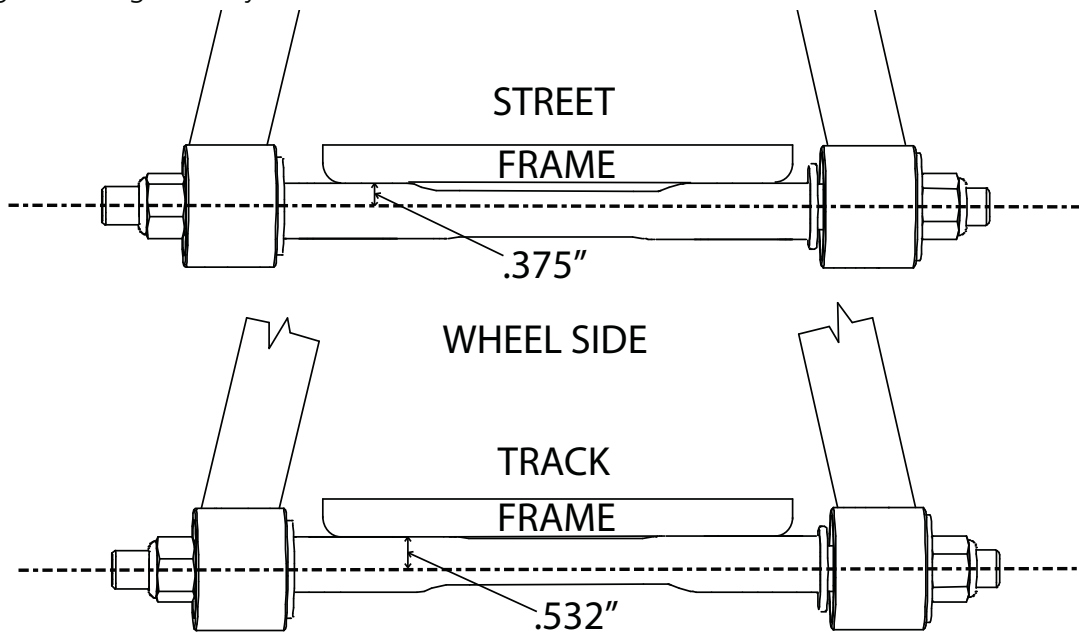

The cross shaft that is used in the upper control arms is offset. The offset combined with the caster slug option allows you to achieve the alignment setting you desire with minimal shims. To change the direction the Icon faces simply spin the cross shaft in the control arm.

If you are after a **Street Alignment** bolt the upper control arm to the frame mount with the arm offset to the outside of the car. The Ridetech icon and caster slugs will be facing the wheel.

If a more aggressive **Track or Autocross** alignment is desired, bolt the control arm to the frame bracket with the arm offset to the inside of the car. The Ridetech icon and caster slugs will be facing the engine.

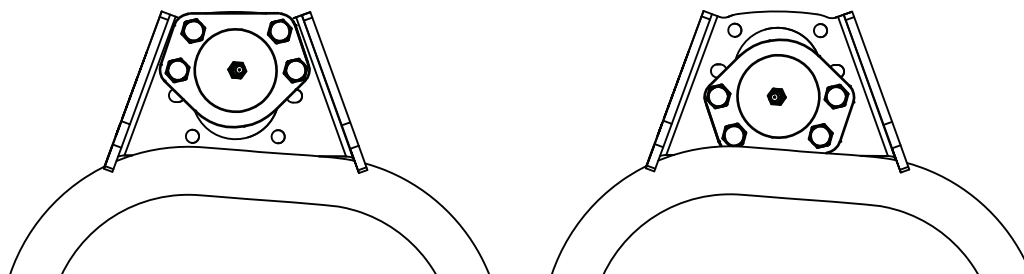

The ball joint can be bolted to the upper control arm in 2 different positions.

If you are after a **Street Alignment** bolt the ball joint to the control arm in the outer position.

If you are planning to run a lot of negative camber for **Track or Autocross**, bolt the ball joint to the control arm in the inner position.



Installing Upper Control Arm and Spindle



8. Bolt the upper Control arm to the car using the previous pages to assist you with Cross Shaft orientation and Caster Slug Location. Install (2) T-Washers and (2) 5/8" Thin Lock Nuts on each Crossshaft. Install the T-Washers with the SMALL RING TOWARD THE BUSHING. Tighten the cross shaft nuts enough to create drag on the delrin bushings, the arm should still move up and down by hand.

Note: The kit comes standard with centered Caster Slugs.

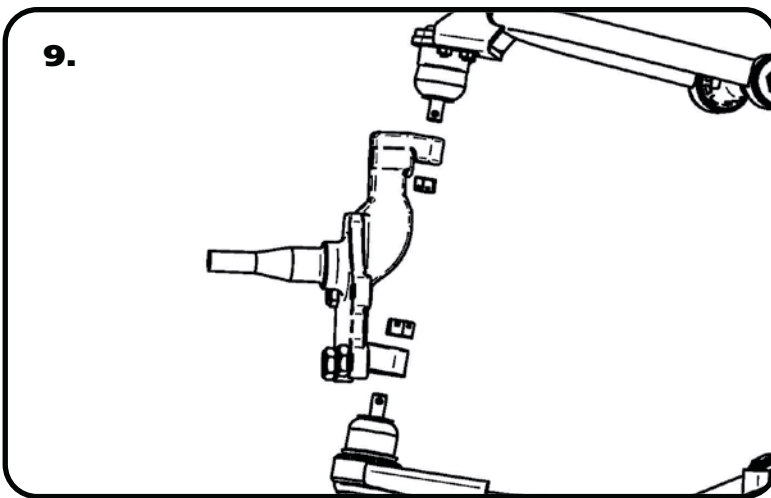

9. Attach the Spindle to the control arms. The Spindle is the same for Driver and Passenger.

Torque Specs:

Lower Balljoint - 65 ftlbs and tighten to line up cotter pin.

Upper Balljoint - 50 ftlbs and tighten to line up cotter pin.

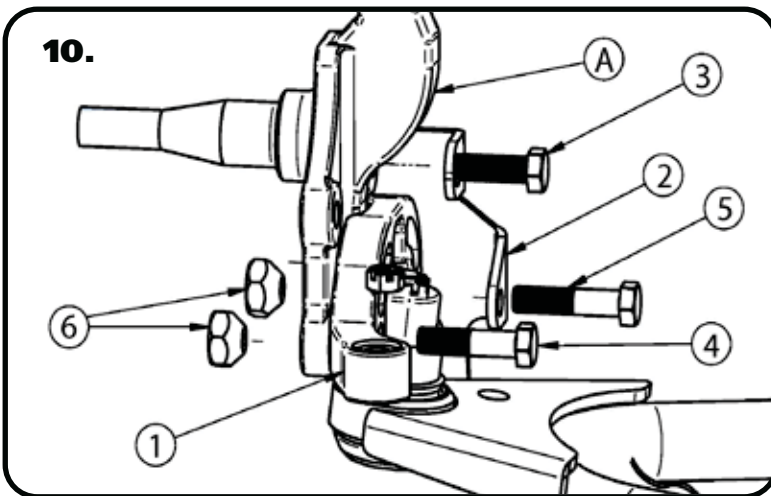

10. Attach Steering Arm(1) and Steering Stop(2) to Spindle(A). 1/2"x 1 1/4"(3), 1/2" x 2"(4), 1/2"x 2 1/2"(5) Hex Bolts, 1/2" Thin Nylok(Used on 3), & Tapered Nuts(6) are used to attach them. The Steering Arm is positioned with the Tie Rod End pointing to the rear of the car and toward the engine. Use Red Loctite (Supplied in the Kit) on the Bolts for the Tapered Nuts and Torque to 75 ftlbs.



Installing TruTurn System

11.

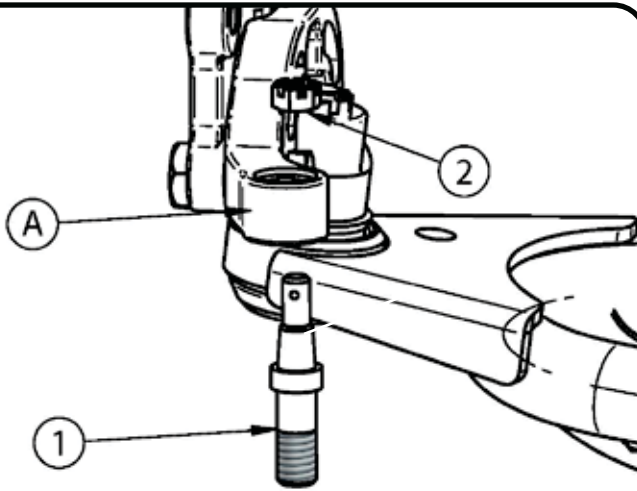

11. Install Outer Tie rod Stud into Steering arm using a 7/16" Castle Nut and 3/32" Cotter Pin. Insert the Tapered end of the Tie Rod Stud into the Taper of the arm. Thread the 7/16" Castle nut on the stud. Torque to 35 ftlbs and then tighten to align Cotter Pin hole with slot on Castle Nut. Install Cotter Pin.

Note: The Outer Tie Rod Stud is the LARGER of the tapered studs in the kit.

12.

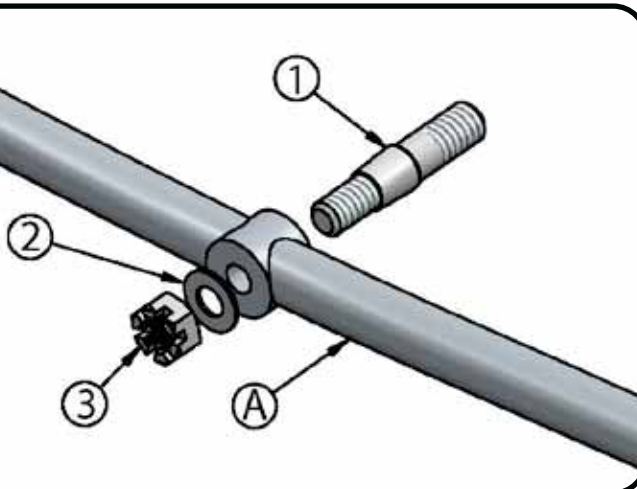

12. Install a Tapered Draglink Stud (1) into the OEM Inner Tie-Rod Hole on the OEM Draglink (A). Install a 7/16" Flatwasher (2) onto the threads. Thread a 7/16" Castle Nut (3) onto the threads to hold it in place. **Do Not Tighten Nut Yet.** It will be tightened after the Draglink Adapter is installed on the Studs. Install Driver and Passenger Studs.

Note: Due to variances in thickness of the OEM Draglink, it may be necessary to install another 7/16" Flatwasher under the Castle Nut to engage to Cotter Pin into the Castle Nut properly.

13.

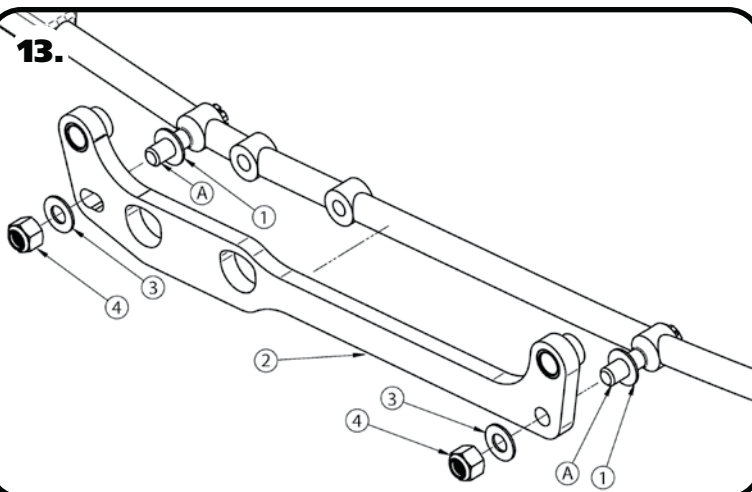

13. Slide a 1/2" Washer (1) onto the Draglink Studs (A). Next, slide the Draglink Adapter (2) onto the Studs (A). The Adapter is positioned with the 2 clearance holes to the Passenger side and the Inner Tie-Rod Mounting holes upward. Tighten the "2" 7/16" Castle Nuts to 35 ftlbs and then tighten to align the cotter pin hole. Install Cotter pin. Install the 1/2" Flatwasher (3) and 1/2" Mechanical Locking Nuts (4) onto the Studs and Torque to 50 ftlbs.



Tie-Rod Assembly and Installation

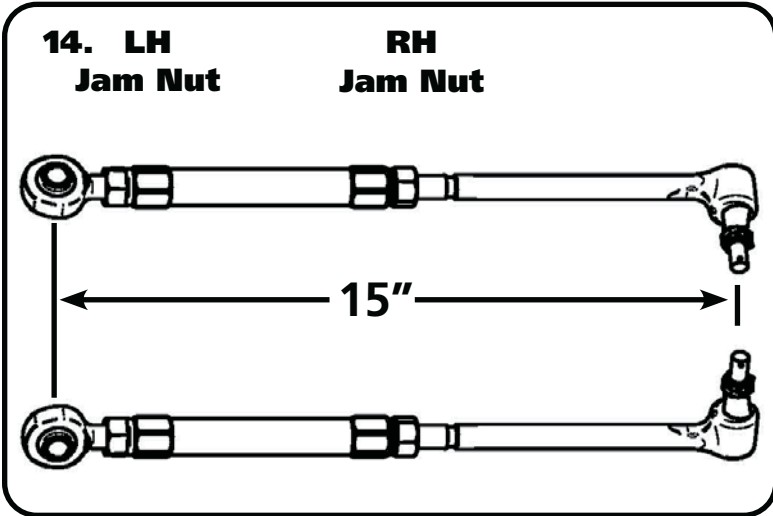

14. Assemble the Tie-Rod to a center to center length of 15" to start with, having equal amount of thread engagement on both ends. These Aluminum adjusters have a left hand thread on one end and a right hand thread on the other. Use anti-seize on the threads of the Tie Rod and Heim end before threading them into the adjuster. **FOR YOUR SAFETY, THE TIE ROD & HEIM NEED A MINIMUM 15/16" OF THREAD ENGAGEMENT INTO THE TIE ROD ADJUSTER.**

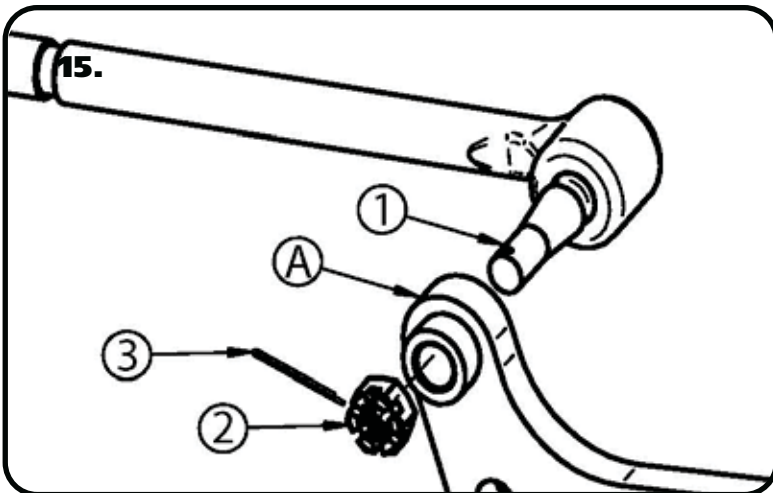

15. Insert the Inner Tie-Rod End(1) into the Draglink Adapter(A). Install the Castle Nut(2) supplied with the Tie-Rod End onto the threads. Torque Castle Nut to 35 ftlbs and tighten to align Cotter Pin hole. Install Cotter Pin(3).

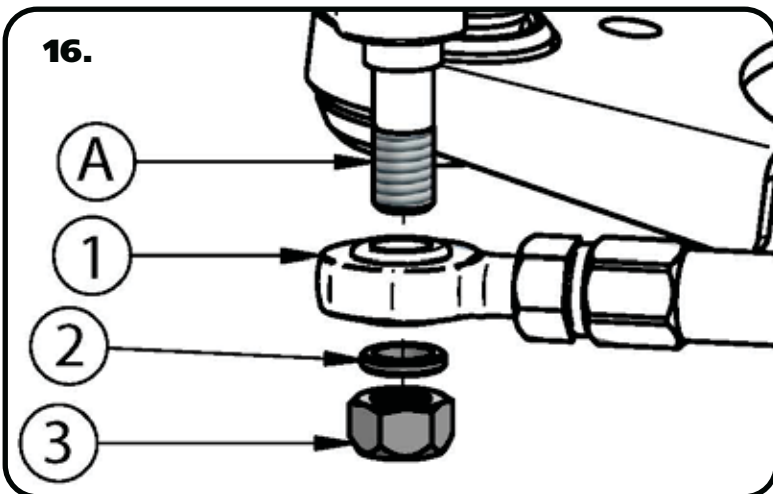

16. Slide the Heim End(1) onto the Tie-Rod Stud(A). Next, slide the Nut Spacer(2) onto the Stud. Thread the 5/8"-18 Mechanical Locking Nut(3) onto the Tie-Rod Stud. Torque nut to 100 ftlbs.



The Finish

15. Tighten all fasteners. If you are going to install the Ridetech MuscleBar, now is a good time to do it.

When assembling the Control Arms tighten the cross shaft nuts enough to create drag on the delrin bushings, the arm should still move through its travel by hand.

Suggested Alignment Specs:

Camber: Street: -.5 degrees
Caster: Street: +3.0 to + 5.0 degrees
Toe: Street: 1/16" to 1/8" toe in