

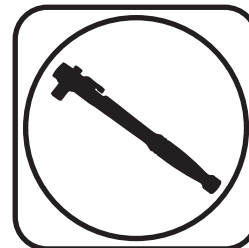

Part # 11569120 - 1990-1996 C4 Front SwayBar

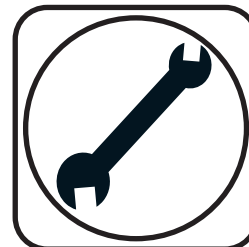

Recommended Tools



**1990-1996 C4 Front SwayBar
Installation Instructions**

Table of contents
 Page 2..... Included Components and Hardware List
 Page 3-5..... SwayBar Installation

Hardware Torque Specifications

5/16"-18	17 ftlbs
3/8"-16	30 ftlbs
M10-1.5.....	37 ftlbs

Major ComponentsIn the box

Part #	Description	QTY
90003165	Front SwayBar	1
90003167	Sway Bar Bushing Frame Spacer	2
90003159	Control Arm Linkage Mount - Driver	1
90003160	Control Arm Linkage Mount - Passenger	1
70015014	Lined Sway Bar Bushing	2
90002513	Sway Bar Bushing Strap	2
90001258	End Link Adapter Spacer	4
70014722	Locking Rings	2

END LINK ASSEMBLY

Part #	Description	QTY
70014735	10mm Female with Stud	2
70014736	10mm Male with Stud	2

HARDWARE KIT.....99010126

QTY	Part Number	Description
SWAYBAR BUSHING FRAME SPACER		
2	99111003	M10-1.5 X 40mm Hex Bolt
SWAYBAR BUSHING STRAP		
2	99111017	M10-1.5 X 60mm SHCS Bolt
8	99113002	M10 Flat Washer
2	99371003	3/8"-16 x 1" Hex Bolt
LINKAGE MOUNT TO CONTROL ARM		
2	99373006	3/8"-16 X 2 3/4" Hex Bolt
6	99373002	3/8" SAE Flat Washer
2	99372001	3/8"-16 Nylok Nut

QTY	Part Number	Description
SHOCK BOLTS TO CONTROL ARM		
4	99311031	5/16"-18 x 2 1/4" Hex Bolt
4	99313001	5/16" SAE Flat Washer
4	99312002	5/16"-18 Nylok Nut
END LINKS TO SWAYBAR AND FRAME MOUNT		
4	99112005	M10-1.5 Flange Lock Kit
2	99112001	M10-1.5 Jam Nuts

Getting Started.....

FOR THE BEST PERFORMANCE, WE RECOMMEND USING RIDETECH'S REAR SWAYBAR. THE PART NUMBER FOR THE REAR SWAYBAR IS 11569122.

This sway bar kit utilizes a anti-friction lining in the sway bar bushing. The lining allows the sway bar to move freely and quietly in the bushing. No lubrication is required.

- 1. Jack the vehicle up to a safe working height and support with jack stands. Make sure the jack stands are stable before working under the car.**
2. Remove the stock sway bar.
3. Remove the OEM end links.



4.

4. Open the Sway Bar Bushing at the split and slide it **OVER** the sway bar. Do this for both bushings.

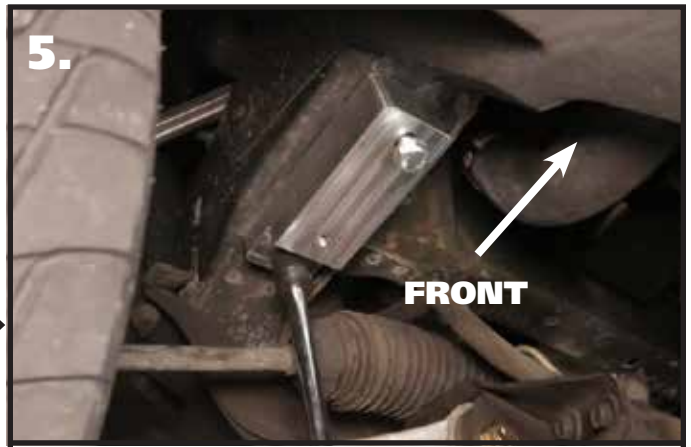

5.

5. Bolt the Aluminum Spacer Block to the frame. The spacer bolt is attached to the frame using a M10-1.5 x 40 bolt and M10 flat washer in the rear hole. A M10-1.5 x 60mm SHCS bolt will be used in the front hole for alignment purposes. Torque the rear bolt. Remove the front bolt, it will get reinstalled later.



6.

6. Slide the swaybar in place.



7.

7. Install the Bushing Straps on the swaybar bushings.



8.

8. Bolt the bushing straps in place using (1) M10-1.5 x 60mm socket head caps screw and M10 flat washer in the front hole. The rear holes uses (1) 3/8"-16 x 1" bolt and M10 flat washer. Insert the hardware through the bushing strap bolting the strap in place. **DO NOT TIGHTEN THE HARDWARE** at this time.



9.

9. Remove the front shock bolt. Slide the Control Arm Linkage Bracket in place. It will mount at the OEM linkage location with a tab that uses the front shock bolt. There is a Driver & Passenger bracket. They will only fit on their corresponding side.



10.

10. Install a 3/8"-16 x 2 3/4" bolts through the bracket and OEM linkage location. Install a 3/8" flat washer and 3/8"-16 nylok nut on the threads of the bolt that are sticking through the bracket. Do Not Tighten until the shock bolt has been installed.



11.

11. Install a 5/16"-18 x 2 1/4" bolt through the outer tab and through the shock t-bar/control arm. Install a 5/16" flat washer and 5/16"-18 nylok nut on the threads sticking through the control arm. Torque all hardware.

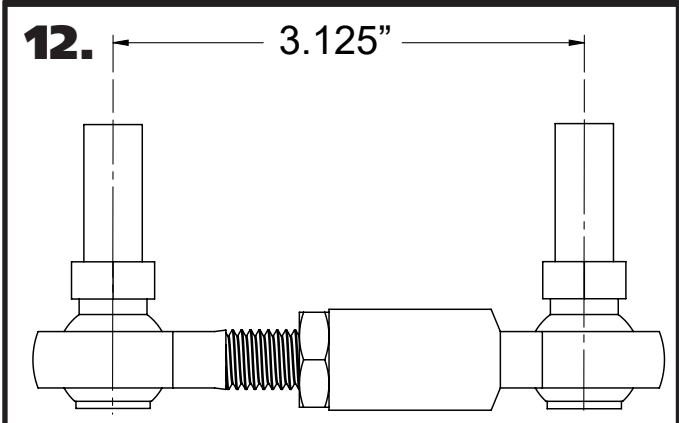

12. 3.125"

12. Assemble the end links. First, thread a M10-1.5 Jam Nut onto the threads of the male endlink body. Next, thread the male endlink body into the female endlink body. Set them to 3 1/8" center to center of the endlinks. Keep the end links parallel with each other and tighten the jam nut against the female endlink.



13.

13. Install a T-bushing on one end of the linkage (small diameter out), with a 3/8" flat washer on the other end. The end with the T-bushing will be the TOP end of the linkage that will be installed in the swaybar end.



14.

14. Install the Linkage with the Studs pointing to the wheel. The linkage will be installed with the previously installed t-bushing in the swaybar end.



15.

15. Install a 3/8" flat washer followed by a M10-1.5 serrated lock nut on the threads of the lower stud of the linkage.



16.

16. Install a 2nd T-bushing on the threads of the upper stud with the small diameter sticking into the swaybar end.



17.

17. Install a M10-1.5 serrated lock nut on the threads of the upper stud of the linkage. Repeat Steps 13-17 on the other side. Torque the hardware.



18.

18. Center the swaybar on the mounts and torque the bushing strap hardware.



19.

19. Disassemble the Locking Rings provided in the kit. The locking rings will need to be installed against the inside edge of the swaybar bushings. Assemble each locking ring against the swaybar bushing and tighten.