

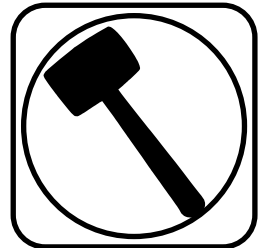

**Part # 11703699 - 2007-2018 Silverado Front Upper StrongArms**



**Recommended Tools**



**2007-2018 Silverado Upper StrongArms  
Installation Instructions**

**Table of contents**  
Page 2..... Upper Control Arm Components & Hardware Kit  
Page 3..... Getting Started  
Page 4..... Upper Control Arm Installation  
Page 5..... Upper Control Arm Installation & Alignment

**THESE CONTROLS ARMS ARE DESIGNED TO FIT TRUCKS WITH CAST STEEL OE CONTROL ARMS.**



### Upper Control Arm Components .....In the box

Item #	Part Number	Description	QTY
1	90001425	Driver Upper Control Arm	1
2	90001426	Passenger Upper Control Arm	1
3	70010827	Delrin Control Arm Bushing	8
4	90001429	Delrin Bushing T-Washer	8
5	90001430	Delrin Bushing Inner Sleeve	4
6	90000910	Upper Ball Joints - Proforged # 101-10046	2

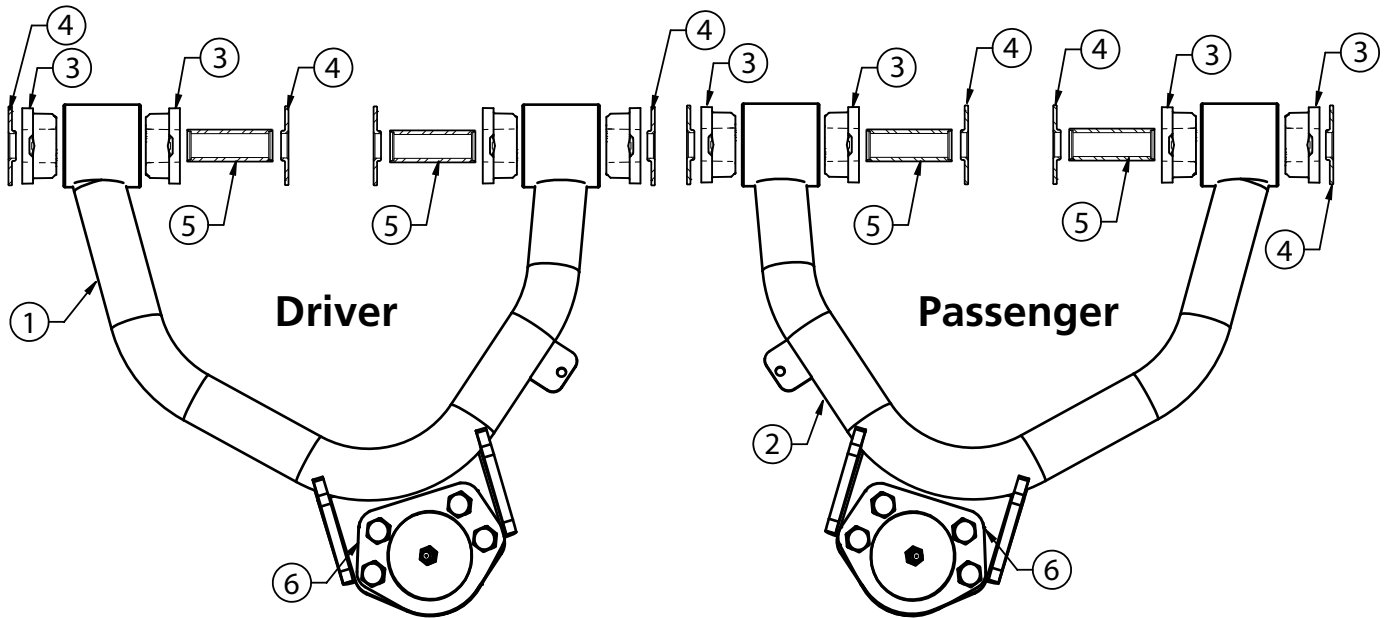

### HARDWARE LIST Kit # 99010156

Part Number	Description	QTY
<b>Upper Balljoint</b>		
99311011	5/16" -18 x 1 1/4" Hex Bolt	8
99312002	5/16" -18 Nylok Nut	8
99313001	5/16" SAE Flat Washer	16
<b>Brake Line Tab</b>		
99251020	1/4" -20 x 1/2" Thread Forming	2



### Getting Started.....

Congratulations on your purchase of the Ridetech 07-13 Silverado StrongArms. These StrongArms have been designed to give your Silverado excellent handling along with a lifetime of enjoyment. Some of the key features of the StrongArms: Ball Joint angles have been optimized for the lowered ride height, Delrin bushings are used to eliminate bushing deflection along with providing free suspension movement through the entire range of travel. The Delrin bushings are made from a material that is self lubricating, so no grease zerks are needed.

### Installation

1. Remove the entire upper control arms from the truck. If you are replacing the lower control arms and spindle, remove them too. Refer to a Factory Service Manual for the proper method.

**NOTE:** We recommend marking the location of the upper control arm adjusters before removing them.

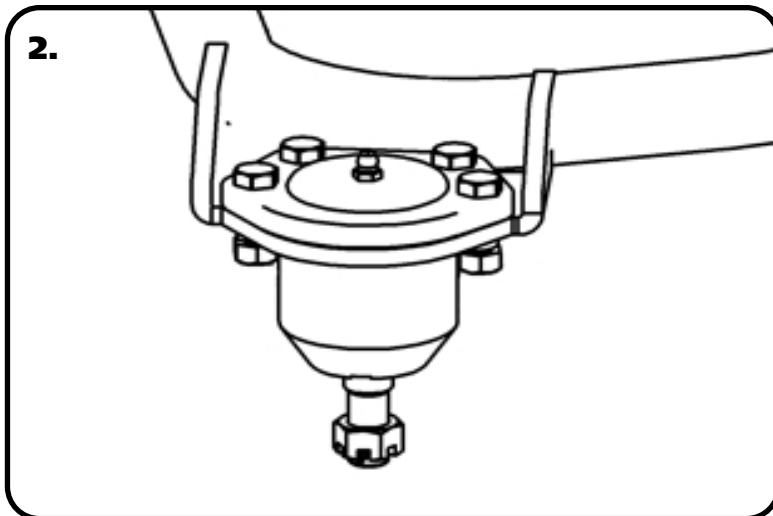

2. Install the ball joints into the upper control arm with the hardware supplied with the ball joint. The upper ball joint goes in from the top side of the control arm. The gussets on the ball joint plate point up. Torque the hardware to 18 ftlbs.

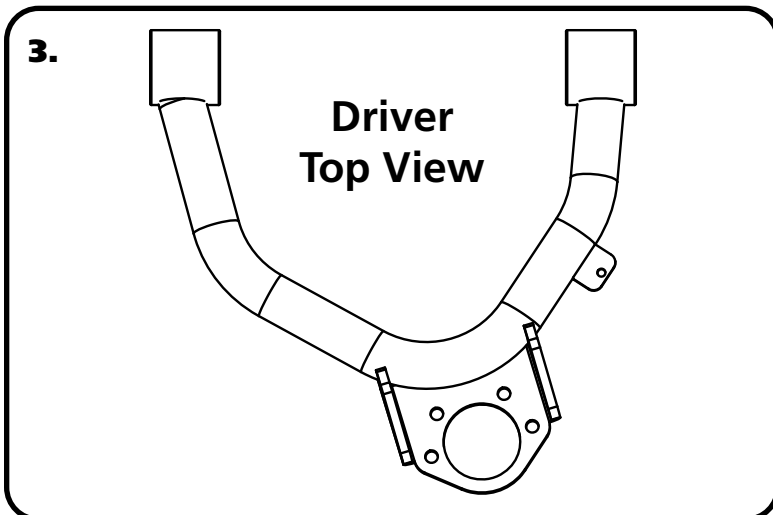

3. The upper control arm is attached to the factory mount using the factory hardware. The driver side arm is shown in **Figure "3"**. The ball joint on the arm is oriented to the rear of the truck. The brake line tab on the control arm will be to the REAR of the control arm.



### Upper Control Arm Installation



4. Insert a t-washer in each side of the control arm bushings. The small diameter of the t-washer goes into the bushing. You may have to tap it in the inner sleeve. The control arm mount will keep the t-washer seated.



5. The upper control arm is attached in the factory mount using factory hardware. The driver side arm is shown in **Figure "5"**. Line up the through holes of the bushings with the OEM slots.



6. Reinstall the OEM adjuster bolts. Make sure the PINS in the frame are located in the slots of the adjuster. Set the adjuster back to the marks made during disassembly and torque to 140 ftlbs.



### Upper Control Arm Installation

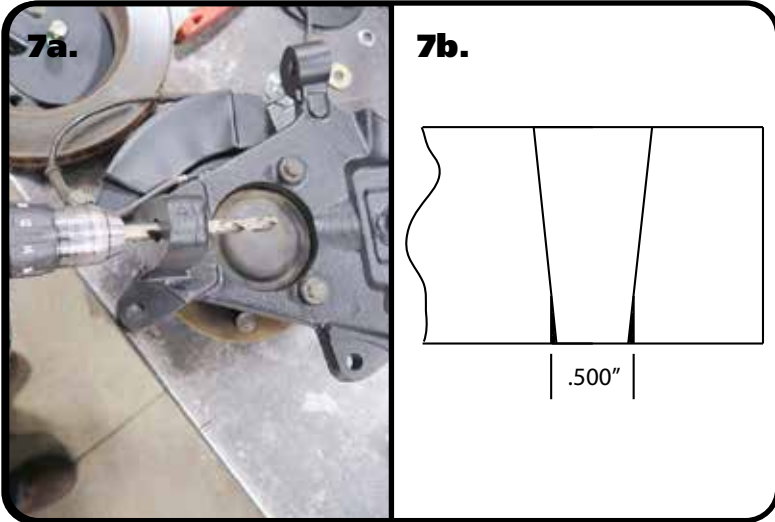

**7.** Before Inserting the pin of the upper balljoint into the spindle, you will need to clearance the bottom of the taper with a 1/2" drill bit. Refer to Images 7a & 7b. Image 7b illustrates the clearanced spindle taper. The drawing is exaggerated for illustration purposes.

- 8a.** Insert the ball joint pin into the spindle.
- 8b.** Install the castle nut on the ball joint pin.

**Torque Specs:**

Lower Ball joint - 50 ftlbs and tighten to line up cotter pin.



Install the cotter pin after tightening the ball joint nut.



**9.** Attach the brake line bracket to the new upper control arm using the supplied thread forming bolts. Align the bracket with the tab on the control arm. Attach it using the thread forming bolts supplied with the kit. These can be threaded in using a ratchet. Put downward pressure on the bolt while turning them. Torque them to 15 inlbs.

**10.** Tighten all fasteners and grease the ball joints.

**11.** Have the vehicle aligned.

Suggested Alignment Specs	
Street Driving	
Camber	-0.4° (+ or - 0.4°)
Caster	+4.0° (+ or - 0.5°)
Toe	+0.1° (+ or - 0.1°)