

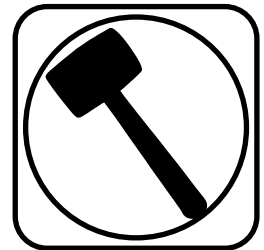

### Part # 11707199 - 2007-2018 Silverado Rear Bolt-in 4 Link

#### Recommended Tools

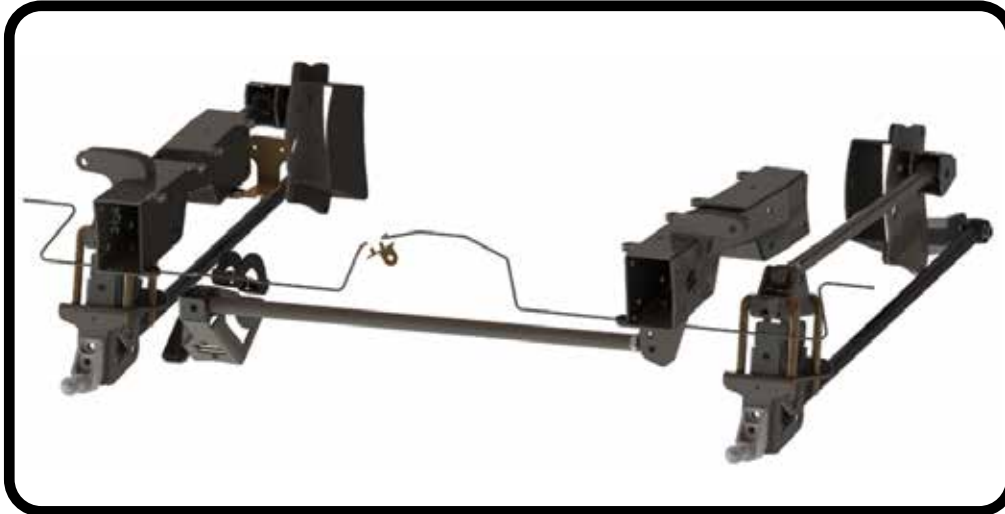

## 2007-2018 Silverado Rear Bolt-in 4 Link Installation Instructions

### Table of contents

Page 2-3.....	Major Components List & Diagram
Page 4.....	Hardware List & R-Joint Information
Page 5.....	Getting Started
Page 6-9.....	Disassembly
Page 9-16.....	C-Notch Installation
Page 16-19.....	Upper Bar Mount Installation
Page 19-22.....	Axle Mount Installation
Page 22-24.....	Lower & Upper Bar Installation
Page 25.....	Lower Shock Mount Installation
Page 25-27.....	Panhard Mount Installation
Page 27.....	Panhard Bar Installation
Page 28-29.....	Shock Installation
Page 29-31.....	Brake Line Installation
Page 32.....	Bed Modifications
Page 33-34.....	Brake Line Bracket Install
Page 34.....	Bumpstop Installation

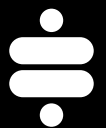



### Major Components ....In the box

Item #	Part #	Description	QTY
1	90001406	Upper Bar Mount - Driver	1
2	90001407	Upper Bar Frame Mount Retainer Plate - Driver	1
3	90001408	Upper Bar Mount - Passenger	1
4	90001409	Upper Bar Frame Mount Retainer Plate - Passenger	1
5	90001410	Lower Axle Mount	2
6	90001411	Upper Axle Mount	2
7	90001412	Frame C-Notch - Driver	1
8	90001413	C-Notch Inner Plate - Driver	1
9	90001414	Frame C-Notch - Passenger	1
10	90001415	C-Notch Inner Plate - Passenger	1
11	90001416	Axle Panhard Mount	1
12	90001417	Axle Panhard Mount Axle Strap	1
13	90001418	Panhard Axle Mount Clamp Plate	1
14	90001419	Upper Bar - 24.210 center to center	2
15	90001420	Lower Bar - 32.700 center to center	2
16	90001421	Panhard Bar - 33.720 center to center	1
17	90001367	Brake Line Relocation Bracket	1
18	90001422	Brake Line Relocation Bracket	1
19	70013322	Short Bumpstop - NOT SHOWN	2
20	90001624	Aluminum Lower Shock Mount	2
21	99626005	U-Bolt 5/8-18 3.13W x 6.06L, Square Shoulder	4
22	90001318	RH R-Joint Threaded Housing End (installed in bars)	5
23	70013949	R-Joint Spacer - .500 ID x .620" (Pair = 1.740" Total Width)	4
24	70013882	R-Joint Spacer - .625 ID x .740" (Pair = 1.980" Total Width)	12
25	70013408	R-Joint Spacer - .625 ID x 1.120" (Pair = 2.740" Total Width)	4
26	90002067	Aluminum Shock Bearing Spacer - Lower - .625" x .450" Long	4
27	70002825	Lower Shock Stud	2
28	99752004	3/4"-16 Jam Nut - installed on R-Joint ends	5
29	70014892	Axle Brake Line - Driver	1
30	70014889	Axle Brake Line - Passenger	1
31	70014885	Driver C-Notch Template - NOT SHOWN	2
32	70014886	Passenger C-Notch Template - NOT SHOWN	2
<b>R-Joint Components - (Installed in bar ends)</b>			
	70013279	Retaining Ring	5
	70013280	Wavo Wave Spring	5
	70013275	R-Joint Center Ball	5
	70013276	R-Joint Composite Center Ball Cage	5



### Part Diagram

**PASSENGER**

**DRIVER**

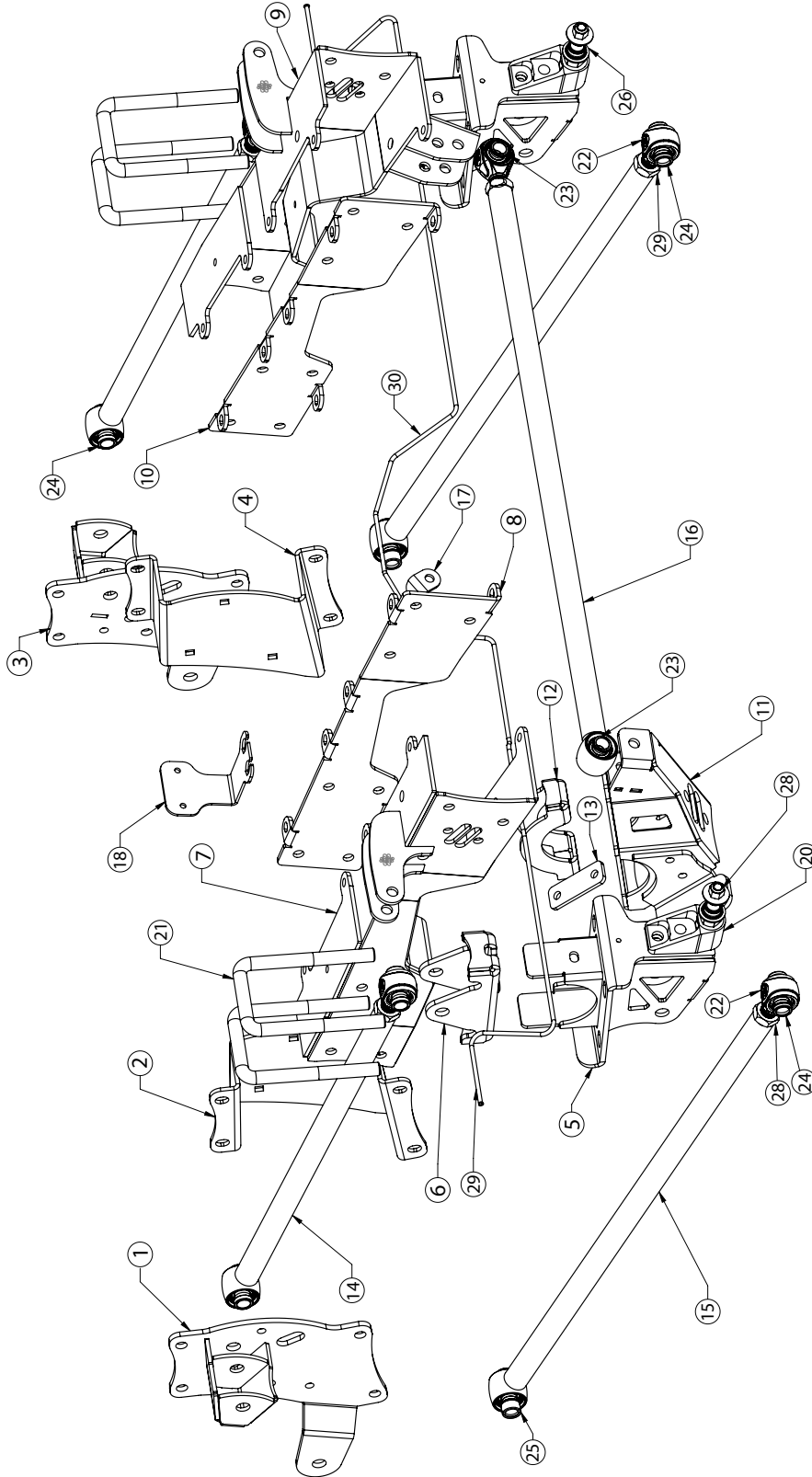



### Hardware List .....In the box (Kit# 99010155)

The 4-Link Kit is supplied with a hardware kit. This hardware kit contains individual bags for the different parts of the installation. The bags are labeled to help determine the correct hardware for the installation of the specific parts of the kit. The instructions will aid you in selecting the correct hardware during the installation.

C-Notches		QTY
99431028	7/16-14 X 4 IN GR. 8 HEX BOLT	8
99431029	7/16-14 X 4.5 IN GR. 8 HEX BOLT	6
99431030	7/16-14 X 5.5 IN GR. 8 HEX BOLT	2
99433005	7/16 SAE FLAT WASHER GR8	36
99432010	7/16-14 NYLOK NUT GR8	18
99371005	3/8-16 X 1.25 GR. 8 HEX BOLT	12
99373002	3/8 SAE FLAT WASHER GR. 8	24
99372001	3/8 -16 NYLOK NUT GR8	12
Frame Bar Mount		
99371070	3/8-16 X 4" CARRIAGE BOLT	6
99373002	3/8 SAE FLAT WASHER GR. 8	6
99372001	3/8 -16 NYLOK NUT GR8	6
99501053	1/2-13 X 1.5" GR. 8 HEX BOLT	8
99503014	1/2 SAE FLAT WASHER GR. 8	16
99502009	1/2-13 GR. 8 NYLOK NUT	8
Axle Lower Bar Mount		
99623001	5/8 SAE FLAT WASHER GR. 8	8
99622001	5/8-18 NYLOK NUT GR 8	8
Lower Bars		
99623001	5/8 SAE FLAT WASHER GR. 8	8
99622006	5/8-18 NYLOK JAM NUT	2
99622001	5/8-18 NYLOK NUT GR 8	2
99621015	5/8-18-4.5" GR. 8 HEX BOLT	2
99621018	5/8-18X 3.25" GR. 8 HEX BOLT	2
Upper Bars		
99621018	5/8-18X 3.25" GR. 8 HEX BOLT	4
99623001	5/8 SAE FLAT WASHER GR. 8	8
99622006	5/8-18 NYLOK JAM NUT	4

Panhard Bar		QTY
99503014	1/2 SAE FLAT WASHER GR. 8	4
99502009	1/2-13 GR. 8 NYLOK NUT	2
99501004	1/2-13 X 3" GR. 8 HEX BOLT	2
Panhard Bar Axle Mount		
99371007	3/8-16 X 1.5 GR. 8 HEX BOLT	4
99372001	3/8 -16 NYLOK NUT GR8	4
99373002	3/8 SAE FLAT WASHER GR. 8	8
99501069	1/2-13 X 1.75" GR. 8 HEX BOLT	2
99502009	1/2-13 GR. 8 NYLOK NUT	2
99503014	1/2 SAE FLAT WASHER GR. 8	4
Rear Shock Mounts		
99501007	1/2-20 X 1.25 GR. 8 HEX BOLT	2
99501009	1/2-20 X 1.75" GR. 8 HEX BOLT	2
99501011	1/2-20 X 2.5 GR. 8 HEX BOLT	2
99502002	1/2-20 GR. 8 NYLOK NUT	6
99503014	1/2 SAE FLAT WASHER GR. 8	8
Shock Stud		
99432002	7/16"-20 NYLOK NUT	2
99433002	7/16" SAE FLAT WASHER	2
99623004	5/8" SAE FLAT WASHER	2
Brake Line Brackets		
99311001	5/16-18 X 1 Hex Cap Screw GR 5	1
99312003	5/16-18 NYLON INSERT L/N ZINC	1
99313002	5/16 SAE FLAT WASHER ZINC	3
99081007	M8-1.25 X 20mm HEX CAP SCREW	1
99101009	#10 x 3/4" SELF DRILLING SCREW	2

## R-Joint Information

### R-JOINT SPACER INSTALLATION

Install the Spacers by inserting the SMALL side of the SPACER into the Center Pivot Ball. Push them in until they bottom out and stop.

### ALL R-JOINTS

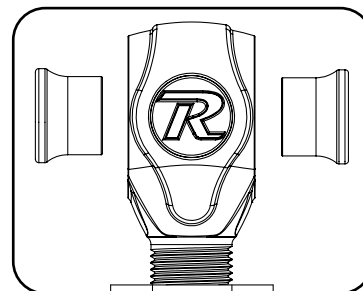

New R-Joints will be quite stiff (75-90 in/lbs breakaway torque) until they "break in" after a few miles of use. After the break in period they will move much more freely. Because the composite bearing race contains self lubricating ingredients, no additional lubrication is needed or desired. Any additional lubrication will only serve to attract more dirt and debris to the R-Joint and actually shorten its life.



### Getting Started.....

Congratulations on your purchase of the Ridetech Rear 4-link System. This system has been designed to give your Silverado excellent handling along with a lifetime of enjoyment. This system provides tunability, replaces the leaf springs, and allows the 4-Link to locate the rearend and the CoilOvers/ShockWaves to support the truck

**Note:** This system is designed for use with the Ridetech Shockwaves or CoilOvers. **The factory shocks and springs will not fit this setup.**

**THE BED AND FUEL TANK WILL NEED TO BE REMOVED TO INSTALL THIS 4-LINK SYSTEM!  
NEW REAR AXLE BRAKE LINES ARE INCLUDED IN THIS KIT. YOU WILL NEED TO BLEED THE  
BRAKES AFTER INSTALLING THIS KIT!**

**THE EXHAUST TAILPIPE MAY NEED MODIFIED TO CLEAR THE NEW REAR SUSPENSION.**

1. Raise the vehicle to a safe and comfortable working height. Use jack stands to support the vehicle with the suspension hanging freely.
2. Support the axle and remove the leaf springs, shocks and tail pipes. Refer to the factory service manual for proper disassembly procedures. The rear seat will also need to be removed.



3. The bed will need to be removed to install this kit. Start by removing the (3) screws around the filler neck. The 3 screws are circled in **Image 3**.



4. Remove the hardware that attaches the bed to the frame. Unplug the tail light wiring from the rear distribution block. We suggest recruiting a few friends to lift the bed off the truck. You will want to position the bed in a way that you have access to the bottom of the bed for later modifications.



### Disassembly



5. Remove the solenoid from the rear corner of the fuel tank. Remove the solenoid by releasing the locking tab and sliding it off the bracket.



6. Disconnect the lines from the top of the fuel pump module.

**COVER THE ENDS OF THE LINES TO PROTECT THEM!**



7. Disconnect the wires from the top of the fuel pump module.



### Disassembly



**8.** Some of the lines have a lock. It will need to be disengaged to remove the lines.



**9.** Unbolt the filler neck ground wire from the front side of the front bed mount.



**10.** Remove the gas tank shield hardware and remove the gas tank shield.



### Disassembly



**11.** Support the center of the fuel tank before removing the gas tank straps. We use a transmission jack to support it. Remove the gas tank strap hardware and straps. Slowly lower the gas tank.



**12.** Remove the brake line retainer from the top of the driver frame rail.



**13.** Remove the ABS sensor wire from the top of the driver frame rail.



### Disassembly & C-Notch Installation



**14.** Unbolt the brake line bracket from the top of the driver frame rail.



**15.** Unbolt the front emergency brake cable bracket from the driver frame rail. Retain the hardware for later reinstallation.



**16.** Unbolt the rear emergency brake cable bracket from the driver frame rail. Retain the hardware for later reinstallation.



### C-Notch Installation



17. To allow maximum drop on this truck, the frame must be notched. The kit includes templates to cut the outside and inside of the frame. The template for the notch will locate off of the large oval hole and top of the frame rail. Start by cutting the large oval hole out of the template. **DO NOT CUT THE NOTCH AREA OF THE TEMPLATE AT THIS TIME.** Line up the large hole of the template with the hole in the frame. At the same time, line the template up with the top of the frame and tape it in place.

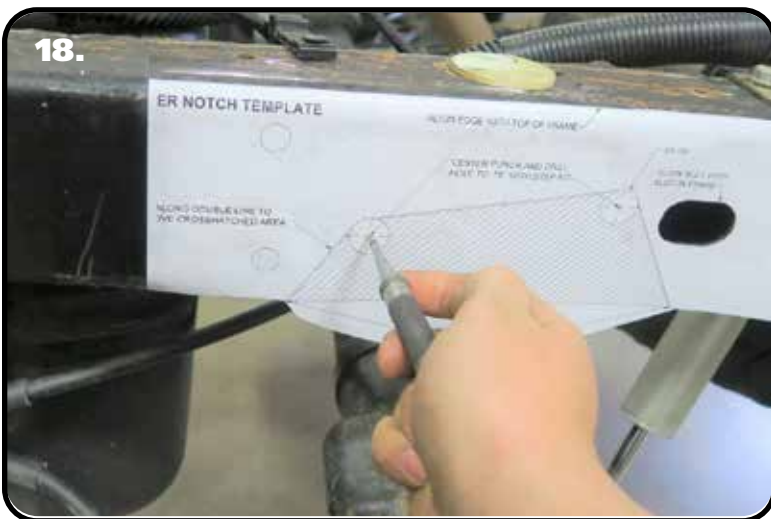

18. Center punch the drill marks of the c-notch corners.



19. We suggest drilling the corner holes with a smaller drill bit first.



### C-Notch Installation

20.

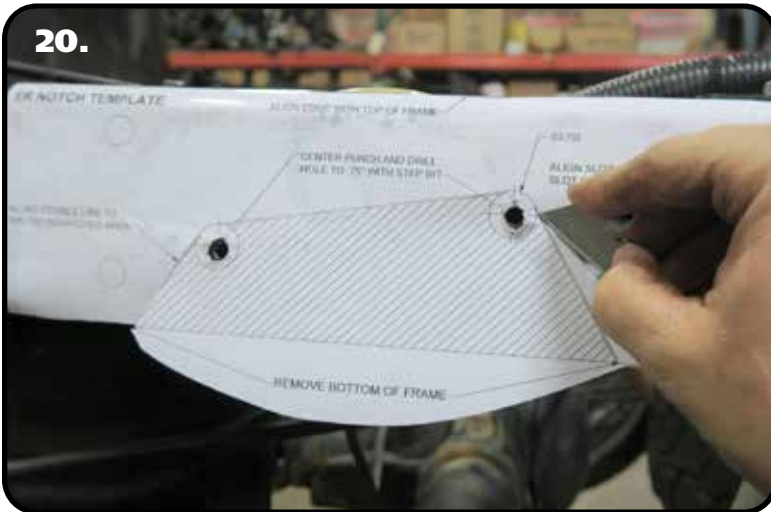

20. Use a razor blade to cut out the hashed area of the template.

21.



21. Trace along the area you just cut out.

22.



22. The corners will get drilled out to 3/4". A unibit works good for this.



### C-Notch Installation



23. Remove the template and cut the line you just traced.



24. Repeat **Steps 17-23** on the inside of the frame rail.



25. You will have to cut across the bottom of the frame rail, connecting the inner and outer cuts. At this point you should be able to remove the section of frame rail.



### C-Notch Installation



**26.** The c-notch will have a snug fit on the frame rail and will most likely need tapped in place with a dead blow hammer.



**27.** Position the inner c-notch plate flat against the inside of the frame with the bolt tabs away from the frame. The bolt tabs will line up with the tabs on the outer c-notch.



**28.** Install a 3/8" flat washer on each of (6) 3/8"-16 x 1 1/4" hex bolts. Insert a bolt/washer in each of the bolt tabs.



### C-Notch Installation



29. Install a 3/8" flat washer and 3/8"-16 nylok nut on each of the (6) bolts. Torque to 45 ftlbs.



30. Using the c-notch as a template, drill the (7) holes in the outside of the frame rail using a 7/16" drill bit.



31. Using the inner c-notch plate as a template, drill the (7) holes in the inside of the frame rail using a 7/16" drill bit.



### C-Notch Installation

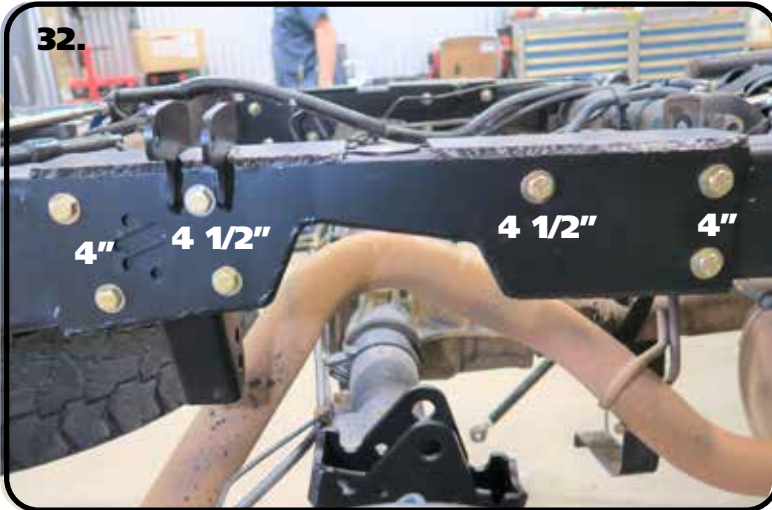

**32.** The c-notch uses 2 different lengths of bolts to bolt through the frame rail. The 2 front and 2 rear holes use 7/16"-14 x 4" hex bolts. The 4 middle holes use 7/16"-14 x 4 1/2" hex bolts. Install a 3/8" flat washer on each of (4) 7/16"-14 x 4" hex bolts and (3) 7/16"-14 x 4 1/2" hex bolts. Insert the bolts through the outer c-notch until they stick through the inner c-notch plate. **Image 32** illustrates the location and lengths of the bolts,



**33.** Install a 7/16" flat washer & 7/16"-14 nylok nut on the threads of the bolts sticking out of the inner c-notch plate. Torque to 70 ftlbs.



**34.** The c-notches require one hole to be drilled through the top and bottom of the frame rail. This hole is located behind the shock mount. Use the c-notch as a template to drill the hole in the top of the frame rail using a 7/16" drill bit.



### C-Notch & Upper Bar Mount Installation



35. Use the c-notch as a template to drill the hole in the bottom of the frame rail that is below the one drilled in **Step 34**. Again, use a 7/16" drill bit.



36. Install a 7/16" flat washer on a 7/16"-14 x 5 1/2" hex bolt. Insert the bolt/washer through the top and bottom of the c-notch. Install a 7/16" flat washer and 7/16"-14 nylok nut on the threads of the bolt. Torque the bolt/nut to 70 ftlbs.

**REPEAT STEPS 17 - 36 ON THE OTHER FRAME RAIL.**

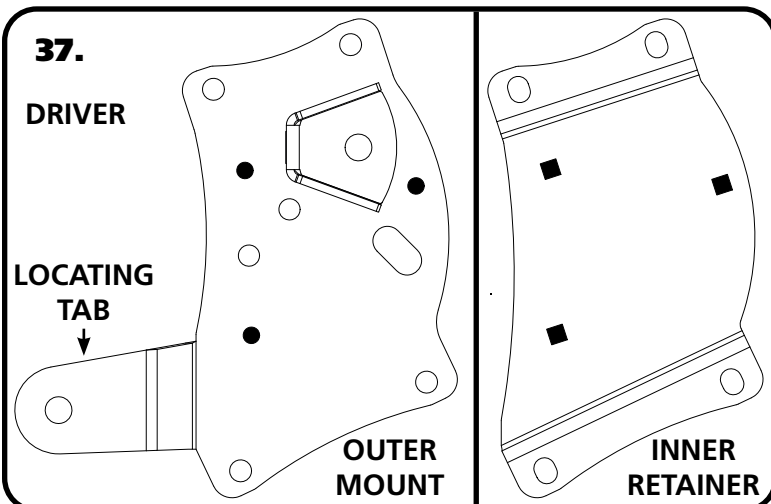

37. The upper bar mount consists of an outer mount and inner retainer. The outer mount has a forward locating tab that is located off the OEM front leaf spring mount. The inner retainer will wrap round the top and bottom of the frame rail. The frame rail will need to be drilled in the areas that are **SOLID BLACK** in **Image 37** after the mount is installed.



### Upper Bar Mount Installation



38. On the driver side, you can insert the emergency brake cable bracket bolt to help hold the mount in place.



39. Insert a 5/8"-18 x 4 1/2" bolt in the front leaf spring mount and front tab of the upper bar mount. The bolt is temporary to help locate the upper bar mount.



40. Slip the inner retainer over the frame rail, aligning the top and bottom mounting holes with the outer mount.



### Upper Bar Mount Installation



41. Install a 1/2" flat washer on each of (4) 1/2"-13 x 1 1/2" hex bolts. Insert the bolt/washer through the (2) top holes & (2) bottom holes of the outer mount and inner retainer. Install a 1/2" flat washer & 1/2"-13 nylok nut on each of the (4) bolts. Torque to 80 ftlbs.



42. Drill the (3) outer holes that are **BLACKED OUT** in **Image 37** using a 3/8" drill bit. Use the outer mount as a template.



43. Drill the (3) inner holes that are **BLACKED OUT** in **Image 37** using a 3/8" drill bit. Use the inner retainer as a template.



### Upper Bar Mount & Axle Mount Installation



**44.** Install the (3) 3/8"-16 x 4" carriage bolts from the **INSIDE** of the frame with the threads sticking through the outer mount. Make sure the square shoulders of the carriage bolts are engaged into the square openings of the inner retainer.



**45.** Install a 3/8" flat washer and 3/8"-16 nylok nut on each of the (3) bolts. Torque to 30 ftlbs. Remove the 5/8"-18 x 4 1/2" bolt from the front leaf spring mount that was used to locate the mount.

**REPEAT STEPS 37 - 45 ON THE OTHER SIDE. THE PASSENGER SIDE WILL NOT HAVE A EMERGENCY BRAKE CABLE BRACKET BOLT.**



**46.** Remove the bolt from the brake line retainer. The brake line retainer bolts to the bracket that is on the rear side of the leaf spring perch. Remove these from both sides of the axle.



### Axle Mount Installation



**47.** Remove the ABS cable from the retainer that is attached to the same bracket as the brake line retainer. Remove the ABS cable retainer from the bracket. These will be reinstalled later.



**48.** The bracket that is at the rear of the OEM leaf spring perch will need to be cut off of the axle tube. We use a saw-z-all to cut it off. It needs to be cut off even with the axle, perpendicular to the top of the leaf spring perch. Use **Images 48 & 49** as a reference.



**49.** **Image 49** illustrates the bracket cut off. Again, we use a saw-z-all to cut it off.



### Axle Mount Installation



**50.** Sit the upper bar mount on the leaf spring pad of the axle. The locating pin needs to insert into the leaf spring locating hole of the leaf spring pad. The upper bar mounts are the same for driver and passenger sides.



**51.** Install a supplied 5/8" u-bolt in each side of the upper bar mount. The u-bolts will nest in the front and rear slots of the upper mount.



**52.** The lower axle mounts are the same for driver and passenger sides. Slide an axle mount on the U-bolts with the top tabs inserted into the leaf spring pad.



### Axle Mount & Lower Bars Installation



**53.** Hold the mount in place and install a 5/8" flat washer and 5/8" high nut on the threads of the u-bolts sticking through the axle mount. Tighten the nuts evenly in a criss-cross fashion making sure the tabs of the axle mount are touching the leaf spring pad evenly. Torque the nuts in a criss-cross fashion to 60 ftlbs. Repeat on the other side.



**54.** Insert the .625" ID x 1.120" long R-Joint spacers into the front of the lower bar (32.700"). The small diameter of the spacer goes into the R-Joint. Insert the front lower bar R-Joint into the front leaf spring mount.



**55.** Line the through hole of the R-Joint with the holes of the leaf spring mount. Install a 5/8" flat washer on to a 5/8"-18 x 4.5" hex bolt, insert into the lined up holes. Install a 5/8" flat washer followed by a 5/8"-18 THIN nylok nut. Repeat on both sides and tighten the bolts/nuts enough to eliminate any gaps.



### Lower & Upper Bars Installation



56. Insert (2) .625" ID x .740" long R-Joint spacers into the R-Joint of one end of each lower bar. The small diameter of the spacer goes into the R-Joint. Insert the rear of the lower bar R-Joint into the lower axle bracket.



57. Line the through hole of the R-Joint with the holes of the axle bracket. Install a 5/8" flat washer on to a 5/8"-18 x 3 1/4" hex bolt, insert into the lined up holes. Install a 5/8" flat washer followed by a 5/8"-18 THIN nylok nut. Repeat on both sides and tighten the bolts/nuts enough to eliminate any gaps.



58. Insert (2) .625" ID x .740" long R-Joint spacers into the R-Joint of one end of each upper bar (24.210"). The small diameter of the spacer goes into the R-Joint. Insert the front upper bar R-Joint into the upper bar mount.



### Upper Bars Installation



59.

59. Line the through hole of the R-Joint with the holes of the bar mount. Install a 5/8" flat washer on to a 5/8"-18 x 3 1/4" Hex bolt, insert into the lined up holes. Install a 5/8" flat washer followed by a 5/8"-18 THIN nylok nut. Repeat on both sides and tighten the bolts/nuts enough to eliminate any gaps.



60.

60. Insert (2) .625" ID x .740" long R-Joint spacers into the rear R-Joint of each upper bar. The small diameter of the spacer goes into the R-Joint. Insert the rear upper bar R-Joint into the upper axle bracket.



61.

61. Line the through hole of the R-Joint with the holes of the axle bracket. Install a 5/8" flat washer on to a 5/8"-18 x 3 1/4" hex bolt, insert into the lined up holes. Install a 5/8" flat washer followed by a 5/8"-18 THIN nylok nut. Repeat on both sides and tighten the bolts/nuts enough to eliminate any gaps.



### Shock & Panhard Mount Installation



**62.** The lower shock mount attaches with (1) 1/2"-13 x 1 1/4" hex bolt, (1) 1/3"-13 x 1 3/4" hex bolt, & (4) 1/2" flat washers, & (2) 1/2"-13 nylok nuts. The lower mount gets attached to the TOP 2 HOLES of the axle mount. When the shock mount is installed correctly, the bottom of the lower shock mount is 1/8" above the bottom of the axle mount. Install a 1/2" flat washer on each bolt. Insert the bolts through the aluminum shock mount with the 1 1/4" long bolt in the top hole, 1 3/4" in the bottom hole. Insert the bolts through the axle mount and install the flat washers & nylok nuts on the threads sticking through. Repeat on both sides and torque the bolts/nuts to 75 ftlbs.



**63. Steps 63-68** cover the installation of the axle panhard mount. The mount will sit against the inside of the driver OEM shock mount. The outer tab will sit against the bottom of the OEM shock mount.



**64.** You will need to drill (2) holes in the side of the OEM shock mount. Hold the panhard mount in position to mark these holes. Drill the 2 holes with a 3/8" drill bit.



### Panhard Mount Installation



**65.** Install a 3/8" flat washer on each of (2) 3/8"-16 x 1 1/2" hex bolts. Hold the panhard mount in position and insert the bolt/washers through the mount and drilled holes. Install a 3/8" flat washer & 3/8"-16 nylok nut on each of the bolts. Do not tighten the hardware at this time.



**66.** Insert the (2) hole backer plate in the OEM shock mount. The hole of the backer will line up with the (2) holes of the panhard mount tab. Install a 3/8" flat washer on each of (2) 3/8"-16 x 1 1/2" hex bolts. Insert the bolts through the locating tab, through the slot in the OEM shock mount, and through the backer plate. Install a 3/8" flat washer & 3/8"-16 nylok nut on each of the bolts. Do not tighten the hardware at this time.



**67.** Position the panhard mount axle clamp on the front side of the axle tube, aligning it with the panhard mount that is already in position.



### Panhard Mount & Panhard Bar Installation



**68.** Install a 1/2" SAE flat washer on each of (2) 1/2"-13 x 1 3/4" bolts. Insert the bolt/washers in the top and bottom mounting holes of the clamp/mount. Install a 1/2" SAE flat washer and 1/2"-13 nylok nut on the threads of each bolt. Torque these bolts to 75 ftlbs. You can now torque the 3/8" hardware that was installed previously. Torque the 3/8" hardware to 45 ftlbs.



**69.** Insert (2) .500" ID x .620" long R-Joint spacers into the R-Joint of one end of the panhard bar (33.720"). The small diameter of the spacer goes into the R-Joint. Insert the panhard bar R-Joint into the panhard mount that is on the axle. Line the through hole of the R-Joint with the holes of the panhard bracket. Install a 1/2" flat washer on to a 1/2"-13 x 3 1/4" hex bolt, insert into the lined up holes. Install a 1/2" flat washer followed by a 1/2"-13 nylok nut. Tighten the bolts/nuts enough to eliminate any gaps.



**70.** Insert (2) .500" ID x .620" long R-Joint spacers into the R-joint in the other end of the panhard bar. The small diameter of the spacer goes into the R-Joint. Insert the panhard bar R-Joint into the panhard mount that is on the passenger c-notch.

**NOTE:** The panhard mount has 2 sets of mounting holes to help set the panhard bar as level as possible depending on your ride height. We start out in the bottom hole.



### Shock Installation



71.

71. Line up the through hole of the R-Joint with the bottom holes of the panhard bracket. Install a 1/2" flat washer on to a 1/2"-13 x 3 1/4" hex bolt, insert into the lined up holes. Install a 1/2" flat washer followed by a 1/2"-13 nylok nut. Tighten the bolts/nuts enough to eliminate any gaps.

**Note:** Steps 72-75 cover the CoilOver/ ShockWave installation. CoilOvers can be installed with the shock body up or down. ShockWaves **must** be installed with the shock body down.



72.

72. Ridetech CoilOvers or ShockWaves require a spacer on each side of the bearing. The upper shock uses a 1/2" ID spacer that is 3/8" long (90002043). The overall width with a spacer on each side will be 1 1/4". **The small side of the spacer goes into the shock bearing.**



73.

73. Insert the Shock with the 1/2" ID Spacers into the shock mount. Install a 1/2" flat washer on a 1/2"-2- x 2 1/2" hex bolt. Line up the holes in the mount with the spacers and shock bearing. Insert the bolt/washer into the lined up holes. Install a 1/2" flat washer & 1/2"-20 Nylok Nut. Torque to 75 ftlbs

**Note:** If installing Shockwaves and you want to locate the air fitting in a different location, the air spring assembly can be rotated on the shock by grabbing the shock and air spring assembly by hand and spinning the shock in the air spring assembly.



### Shock & Brake Line Installation



74.

74. Install a 5/8" flat washer onto the 5/8"-18 threads of the shock stud. Apply Red Loctite to the 5/8" threads of the stud. Thread the shock stud into the threaded hole of the lower mount. Repeat on both sides and torque the shock stud to 65-75 ftlbs. The shock stud requires spacers that are .400" long (90002067). Install a 5/8" ID 90002067 spacer (**small side towards shock body**) onto the lower shock stud. Slide the bottom of the shock onto the stud. Install a second 5/8" ID 90002067 Spacer onto the stud (**small side towards shock**). You may need to jack the rear end up to slide the shock onto the Stud.



75.

75. Install the 7/16" flat washer and 7/16" nylok nut. Tighten the upper and lower shock bolts. Torque the upper bolt to 50 ftlbs and the lower nut to 40 ftlbs. The designed ride height of the CoilOver/Shockwave is 14 1/2" center to center.



76a.

76a & 76b. Your truck could have 2 different brake line setups depending on the brake package the truck came with. **Images 76a & 76b** show each setup. This does not affect the mounting of the brake bracket. Remove the OEM brake line bracket that attaches to the differential cover bolt and brake line mount. Attach the new brake line bracket to the differential using the supplied M8-1.25 x 20mm bolt and 5/16" flat washer. Attach the brake line mount to the new brake line tab using (1) 5/16"-18 x 1" bolt, (1) 5/16"-18 nylok nut, and (2) 5/16" flat washers. Torque the M8 to 225 inlbs and the 5/16" to 17 ftlbs.



### Brake Line Installation

76b.



**76b.** This is the other brake line possibility. Remove the OEM brake line bracket that attaches to the differential cover bolt and brake line mount. Attach the new brake line bracket to the differential using the supplied M8-1.25 x 20mm bolt and 5/16" flat washer. Attach the brake line mount to the new brake line tab using (1) 5/16"-18 x 1" bolt, (1) 5/16"-18 nylok nut, and (2) 5/16" flat washers. Torque the M8 to 225 inlbs and the 5/16" to 17 ftlbs.

77.



**77.** The kit includes new brake lines for the rear axle. We recommend removing and installing (1) brake line at a time. Start by removing the plastic brake line clamps from the axle tubes.

**NOTE:** The new supplied brake lines are designed to be compatible with drum brakes. If you have or will be running disc brakes, an extra bend will need to be added to the supplied brake lines as shown on the right side in Figure 79 on the next page.

78.



**78.** Remove the bolt from the clamp on the passenger axle tube. Retain the bolt for installation of the new brake line. The brake line clamp that is on the OEM line will need to be removed to be reinstalled on the new brake line.



### Brake Line Installation



**79.** Remove the OEM brake line from the wheel cylinder using a line wrench.

**NOTE:** If you have or will be running disc brakes, an extra bend will need to be added to the supplied brake lines as shown on the right side in Figure 79.



**80.** Remove the opposite end that is threaded into the rubber hose. Replace the line with the new one supplied. Replace the other axle brake line. Use a line wrench to tighten the brake lines. Reinstall all of the clamps that were removed previously.

**NOTE:** If your truck has a single rubber line attaching to the axle, see **Step 81**.

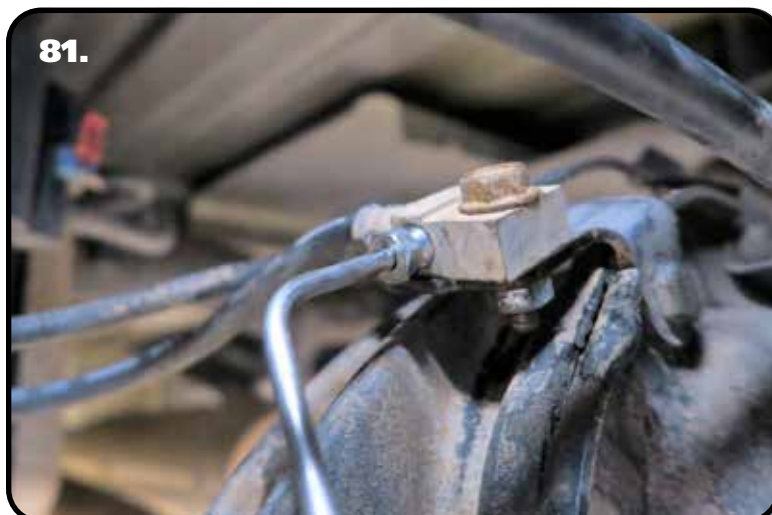

**81.** If your truck has a single rubber line attached to the axle, you will need to tweak the end of the brake line to thread it into the hose end.

**REINSTALL THE GAS TANK IN REVERSE ORDER OF REMOVING IT.**



### Bed Modifications

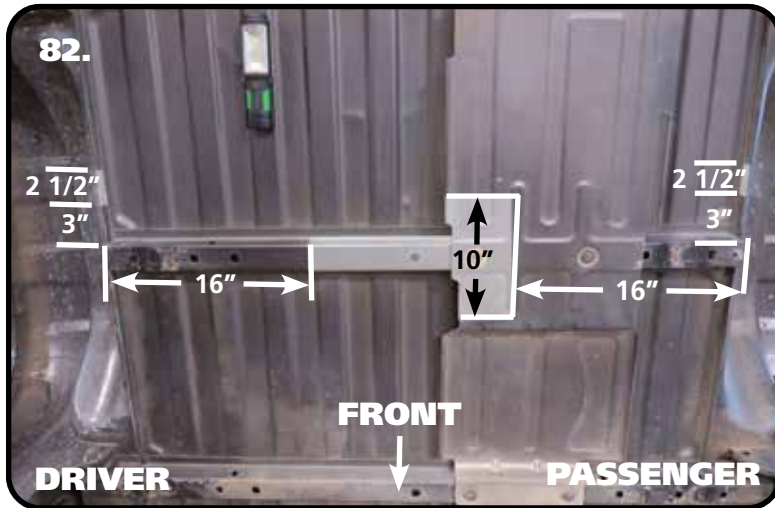

**82.** Trimming of the bed brace that is in between the wheel wells is necessary to clear the c-notches. The inside fender well lip will need to be cut to clear the shock mount. We cut ours with a die-grinder. **Image 82** shows the areas that will need cut out. **Step 83** covers the notching of the heat shield and bed brace. **Step 84** covers the cutting of the fender well lip.

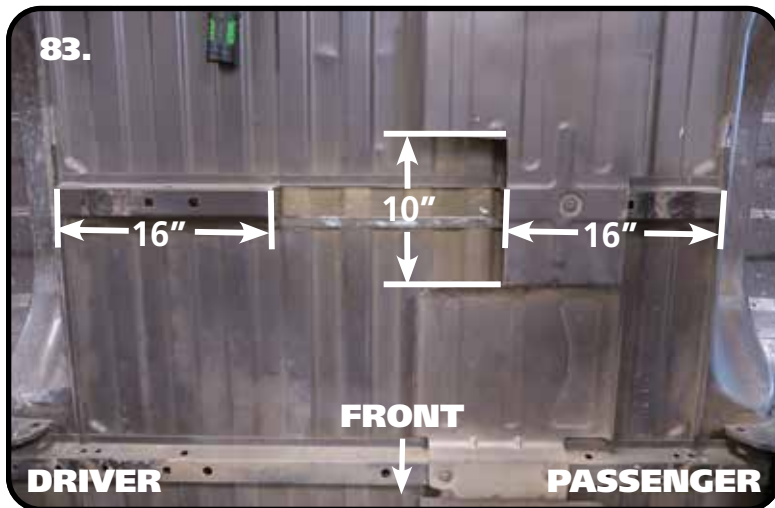

**83.** The bed brace cut starts 16" from each end of the bed brace. The heat shield on the passenger side will need notched for axle clearance. It is notched 5" forward and back from the center of the bed brace. Cut the bed brace even with the bent flange that attaches it to the bed floor.

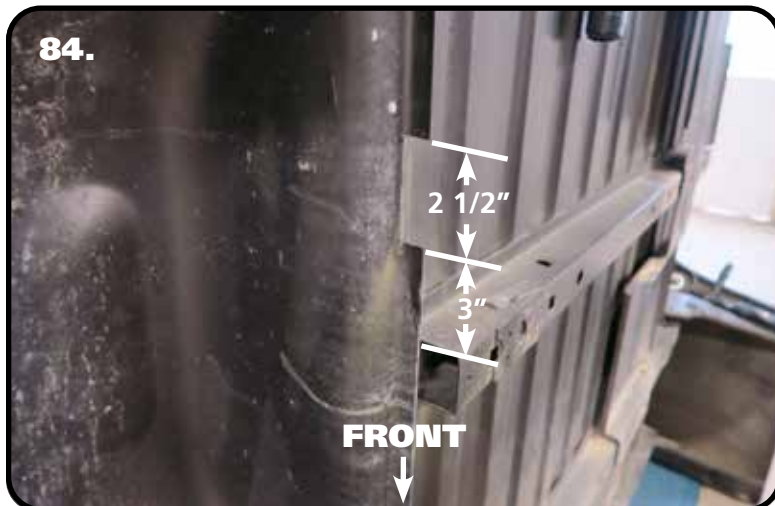

**84.** The inside fender well lip needs to be cut to clear the shock mount. The rear of the cut out is 3" behind the bed brace. The cut out needs to be 2 1/2" long.



### Brake Line Bracket Install



**85.** The brake line bracket that bolted to the top of the driver frame rail will need to be replaced with one supplied in the kit. Start by loosening the lines using line wrenches.

**Note:** Your truck may only have one line attached to the bracket.



**86.** Remove the clips that hold the brake lines in place. Retain the clips for installation of the new bracket.



**87.** Separate the lines and remove them from the bracket. Thread the lines back together and tighten them using line wrenches. The new bracket has slots for the lines to slip through.

**REINSTALL THE BED IN REVERSE ORDER OF REMOVING IT.**



### Brake Line Bracket & Bumpstop Install



**88.** Slip the brake line(s) into the new bracket and reinstall the clips. Screw the brake line bracket to the bed brace using the supplied #10 x 3/4" self drilling screws.



**89.** The c-notch openings above the axle are threaded to receive a bumpstop. Thread the bumpstops into the c-notches.

**90.** Bleed the rear brakes to eliminate any air that is in the system from having the brake lines open.

**Be sure to check for any leaks after bleeding the brakes.**

The designed ride height of the CoilOver/Shockwave is 14 1/2" center to center.

**Double check all the hardware to ensure it is tight.**