

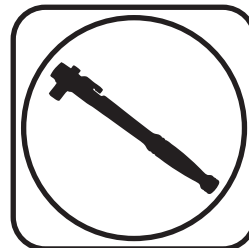

Part # 11709120 - 2007-2018 Silverado Front SwayBar

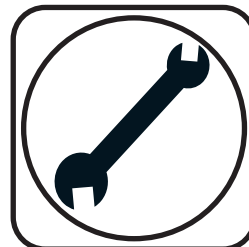

Recommended Tools



2007-2018 Silverado Front SwayBar Installation Instructions

Table of contents

- Page 2..... Included Components and Hardware List
- Page 2-4..... SwayBar Installation

Hardware Torque Specifications

- M10-1.5..... 37 ftlbs
- 3/8"-16..... 30 ftlbs

www.ridetech.com 

REV3 8/14/23

Major ComponentsIn the box

Part #	Description	QTY
90001376	Front Sway Bar	1
90001258	Sway Bar End Link T-Bushing	4
70015016	Lined Sway Bar Bushing	2
90001346	Bushing Strap	2
90001377	Bushing Mount Adapter	2
70014491	Locking Ring	2

END LINK ASSEMBLY

Part #	Description	QTY
90001379	90 Degree End Link Adapter	2
90002571	90 Degree End Link	2
99431017	7/16"-20 x 2 3/4" Hex Bolt - stamped control arms	2
99431026	7/16"-20 x 3" Hex Bolt - forged control arms	2
90002934	End Link Kit	1
99433010	7/16" Stainless Washer	4

HARDWARE KIT99010132

QTY	Part Number	Description
ADAPTER PLATE		
4	99111001	M10-1.5 x 30mm Flat Head
1	90002263	Red Loctite

QTY	Part Number	Description
BUSHING STRAP		
4	99372001	3/8"-16 Nylok Nut
4	99373002	3/8" SAE Flat Washer

Getting Started.....

This sway bar kit utilizes a anti-friction lining in the sway bar bushing. The lining allows the sway bar to move freely and quietly in the bushing. No lubrication is required.

1. Jack the vehicle up to a safe working height and support with jack stands. Make sure the jack stands are stable before working under the vehicle.

2. Remove the stock sway bar.



3. Open the sway bar bushing at the split and slide it **OVER** the swasy bar. Do this for both bushings.



4. Slip the Bushing Straps over the SwayBar Bushings.

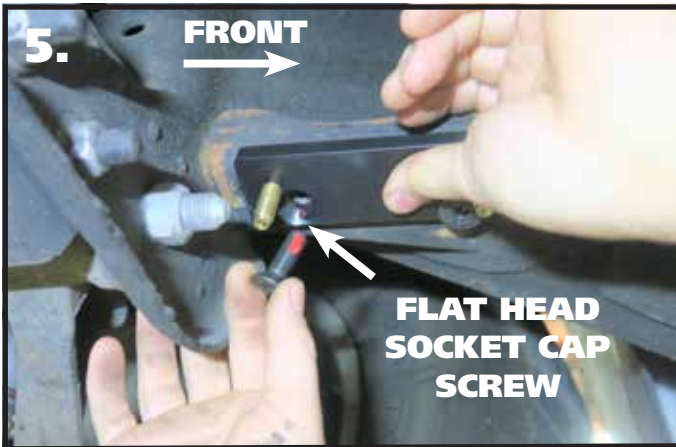

5. Hold the Frame Plate up to the OEM holes, the STUDS will need to be positioned to the CENTER of the truck. Apply Red Loctite to the M10-1.5 x 30mm Flat Head Bolts. Thread the bolts into the holes. Torque the bolts.

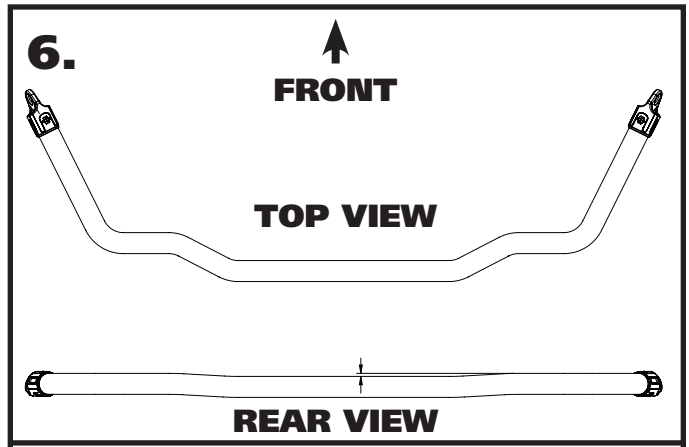

6. Image 6 illustrates the correct orientation of the swaybar. With the arms level, the center of the bar should be lower than the arms.



7. Slide the swaybar into position with the center of the bar being the lowest point. Slip the swaybar bushing straps onto the studs of the mounting plates.



8. Install a 3/8" flat washer and 3/8"-16 nylok nut on each of the 4 studs. Roughly center the bar and torque the nylok nuts.

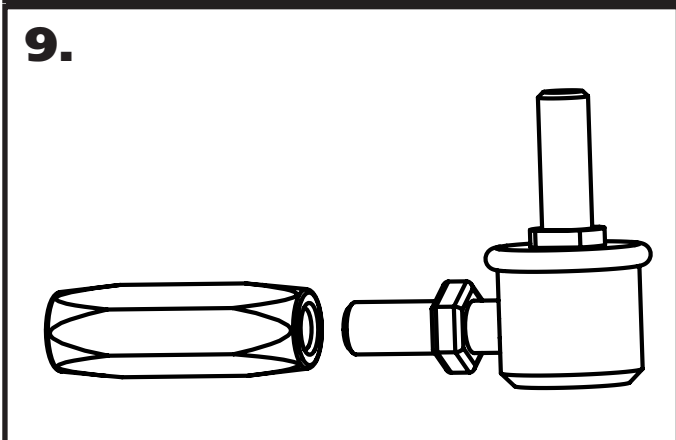

9. The swaybar end links will need to be partially assembled before they can be installed. Using your fingers, thread the jam nut all the way on until it stops. Thread the spacer onto the stud until it stops against the jam nut.

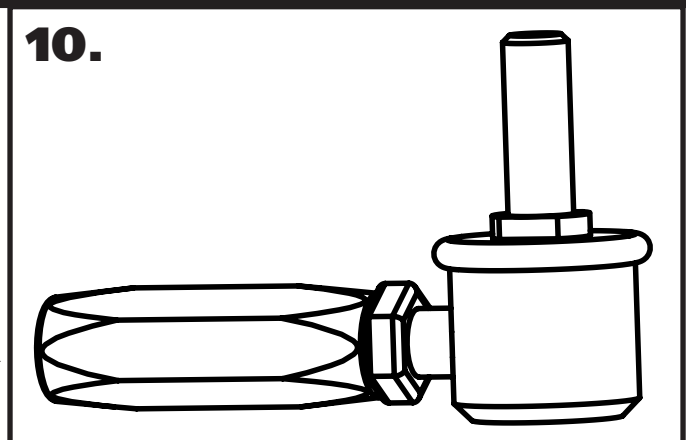

10. Use 2 wrenches to lock the jam nut against the spacer. Your assembly should look like Diagram 10.



11.

11. Install a T-Bushing on each of the 90 degree end links. The t-bushings are installed with the large diameter against the shoulder of the end link.



12.

12. Insert the 90 degree end link/t-bushing into the swaybar end with the threads pointing toward the center of the truck.



13.

13. Install a 2nd t-bushing with the small diameter into the swaybar.



14.

14. Install the nut that came supplied on the end and torque. Do this for both sides.

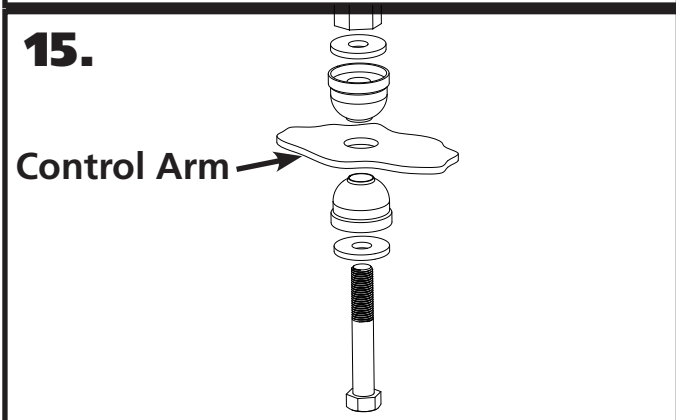

15.

15. Install the End Links using **Diagram 15** as a reference. The supplied 7/16"-20 x 3" or 7/16"-14 x 2 3/4" bolt is used to attach the end links to the control arm. Stamped Steel arms will use the 2 3/4" long bolt. All other control arms will use the 3" long bolt. Install both end links before tightening the end link hardware. Use the supplied Red Loctite on the bolt and tighten it until it bottoms out.



16.

16. Install the stop rings against the swaybar bushing. The stop rings will go against the inner side of the bushing. Take the stop rings apart and reassemble them against the bushing and tighten.