



Part # 11710204/11710205

2014-2018 Silverado 1500 2WD/4WD CoilOver Kit

Front Components:

- 11713699 Front Upper StrongArms
- 11703110/11703115 Front Coilovers
- 11709120 Front MuscleBar
(Optional, Purchased Separate)

Rear Components:

- 11707199 Rear 4-Link System
- 11706510 Rear Coilover Instructions

Miscellaneous Components:

- 85000000 Spanner Wrench

Recommended Tools

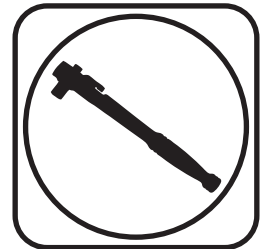

14-18 Silverado Coilover System Installation Instructions

Table of contents

- Pages 2-6..... Upper StrongArms
- Pages 7-15..... Front Coilovers
- Pages 15-18..... Front MuscleBar
- Pages 23-52..... Rear 4Link
- Pages 53-55.....Rear CoilOver
- Pages 56-57.....Shock Adjustment

THESE CONTROLS ARMS ARE DESIGNED TO FIT TRUCKS WITH ALUMINUM OR STAMPED STEEL OE CONTROL ARMS.



Part # 11713699 - 2014-2018 Silverado Front Upper StrongArms



Recommended Tools

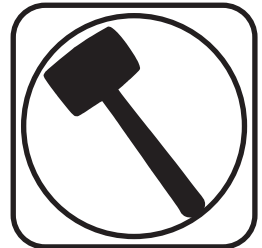

2014-2018 Silverado Upper StrongArms Installation Instructions

Table of contents

- Page 3..... Upper Control Arm Components & Hardware Kit
- Page 4..... Getting Started
- Page 5..... Upper Control Arm Installation
- Page 6..... Upper Control Arm Installation & Alignment

THESE CONTROLS ARMS ARE DESIGNED TO FIT TRUCKS WITH ALUMINUM OR STAMPED STEEL OE CONTROL ARMS.



Upper Control Arm ComponentsIn the box

Item #	Part Number	Description	QTY
1	90003451	Driver Upper Control Arm	1
2	90003452	Passenger Upper Control Arm	1
3	70016040	Upper Ball Joints - Proforged 101-10502/Moog K500340	2
4	70010827	Delrin Bushing Half	8
5	90001429	Delrin Bushing T-Washer	8
6	90001430	Delrin Bushing Inner Sleeve	4

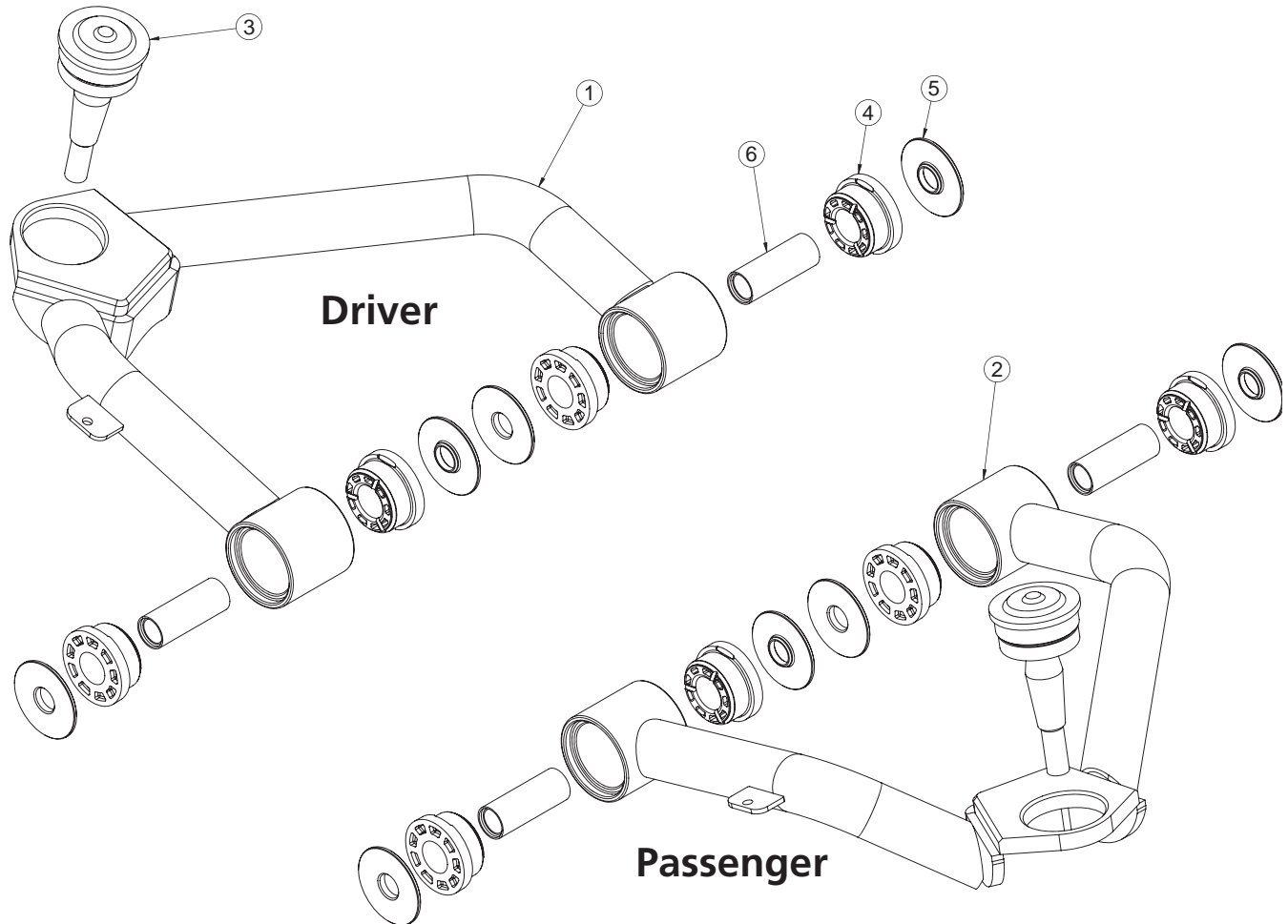

Hardware ListIn the box (Kit # 99010237)

Part Number	Description	QTY
Brake Line Tab		
99251020	1/4"-20 x 1/2" Thread Forming Screw	2



Getting Started.....

Congratulations on your purchase of the Ridetech 2016-2018 up Silverado StrongArms. These StrongArms have been designed to give your Silverado excellent handling along with a lifetime of enjoyment. Some of the key features of the StrongArms: Ball Joint angles have been optimized for the lowered ride height, Control arm length has been optimized for the lowered ride height.

Installation

1. Remove the entire upper control arms from the truck. Retain the OEM hardware for installation of the new control arms. If you are replacing the shock/spring assembly, install them in conjunction with the upper control arms. Refer to the CoilOver instructions for installation.



2. Remove the brake line tab from the upper arm.

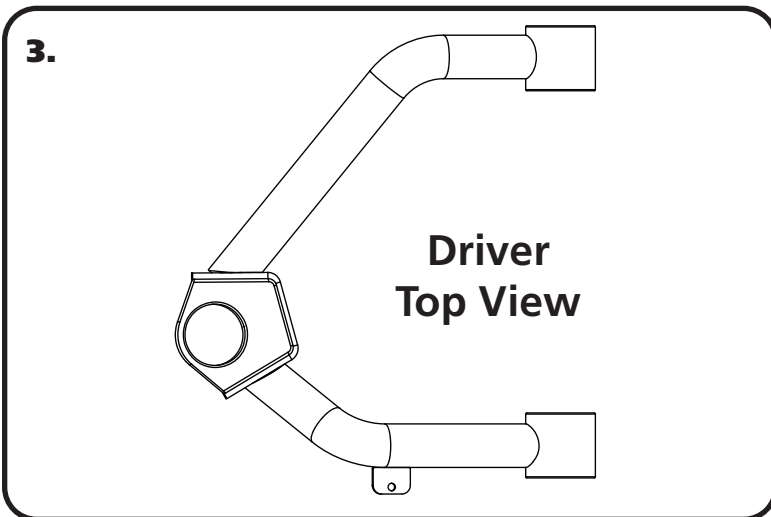

3. The upper control arm is attached to the factory mount using the factory hardware. The driver side arm is shown in **Figure "3"**. The ball joint on the arm is oriented to the rear of the truck. The brake line tab on the control arm will be to the REAR of the control arm.



Upper Control Arm Installation



4. Insert a t-washer in each side of the control arm bushings. The small diameter of the t-washer goes into the bushing. You may have to tap it in the inner sleeve. The control arm mount will keep the t-washer seated.



5. The upper control arm is attached in the factory mount using factory hardware. The driver side arm is shown in **Figure "3, 4 & 5"**. Line up the through holes of the bushings with the OEM holes.



6. Reinstall the OEM bolts. Snug the hardware down for now. The upper control arm bolts need to be torqued to 140 ft-lbs.



Upper Control Arm Installation



7. Insert the pin of the upper ball joint into the spindle.



8. Install the ball joint nut on the ball joint pin.

Torque Specs:

Lower Ball joint - 50 ftlbs and tighten to line up cotter pin.

Install the cotter pin after tightening the ball joint nut.



9. Attach the brake line bracket to the new upper control arm using the supplied thread forming bolts. Align the bracket with the tab on the control arm. Attach it using the thread forming bolts supplied with the kit. These can be threaded in using a ratchet. Put downward pressure on the bolt while turning them. Torque them to 15 inlbs.

10. After putting the truck back on the ground, torque the upper control arm mounting bolts to 140 ft-lbs. Grease the ball joints.

11. Have the vehicle aligned.

Suggested Alignment Specs	
Street Driving	
Camber	-0.4° (+ or - 0.4°)
Caster	+4.0° (+ or - 0.5°)
Toe	+0.1° (+ or - 0.1°)



Part # 11703110/11703115 - 2007-2018 Silverado 2WD/4WD HQ Front CoilOvers



Recommended Tools

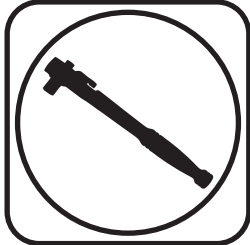

2007-2018 Silverado 2WD/4WD Front CoilOvers Installation Instructions

Table of contents

- Page 12-13..... Included Components
- Page 14..... Disassembly and Getting Started
- Page 15-16..... Assembling CoilOvers
- Page 17-18..... Installation of CoilOver Assembly
- Page 19..... CoilSpring Adjustment

THIS KIT IS DESIGNED TO REPLACE THE OEM SHOCK/SPRING SETUP.



Major ComponentsIn the box

Item #	Part #	Description	QTY
1	90001368	Upper CoilOver Mount Assembly	2
2	90001369	Lower CoilOver Mount Assembly	2
3	982-10-804	4.1" Stroke HQ Series Shock	2
4	815-05-022-kit	Shock Eyelet Assembly	2
5	90001994	5/8" ID Bearing (installed in shock eyelet/body)	4
6	90001995	Bearing Snap Ring (installed in shock eyelet/body)	8
7	803-00-199(kit)	Lower Spring Adjuster Nut	2
8	803-00-199(kit)	Adjuster Nut Locking Screw	2
9	803-00-199(kit)	Upper CoilSpring Retaining Plate	2
10	803-00-199(kit)	CoilSpring Plate Retaining Ring	2
11	70010828	Delrin Spring Washer	4
12	59100800 (2WD) or 59080850 (4WD)	CoilSpring 10" (2WD) 800lb - 2WD or CoilSpring 8" (4WD) 850lb - 4WD	2 or 2
13	90002043	.500" x .365" Shock Bearing Spacers	8
	85000000	Spanner Wrench	1

HARDWARE LIST Kit # 99010130

QTY	Part Number	Description
FRONT UPPER SHOCK MOUNT		
2	99501064	1/2"-13 x 2 3/4" Hex Bolt
2	99502001	1/2"-13 Nylok Nut
2	99503001	1/2" SAE Flat Washer
6	99431023	7/16"-14 x 1 3/4" Hex Bolt
6	99432010	7/16"-14 Nylok Nut
12	99433005	7/16" SAE Flat Washer
FRONT LOWER SHOCK MOUNT		
2	99501064	1/2"-13 x 2 3/4" Hex Bolt
2	99502001	1/2"-13 Nylok Nut
2	99503001	1/2" SAE Flat Washer
4	99371061	3/8"-16 x 2 1/4" Hex Bolt
4	99372001	3/8"-16 Nylok Nut
8	99373002	3/8" SAE Flat Washer



Major ComponentsIn the box

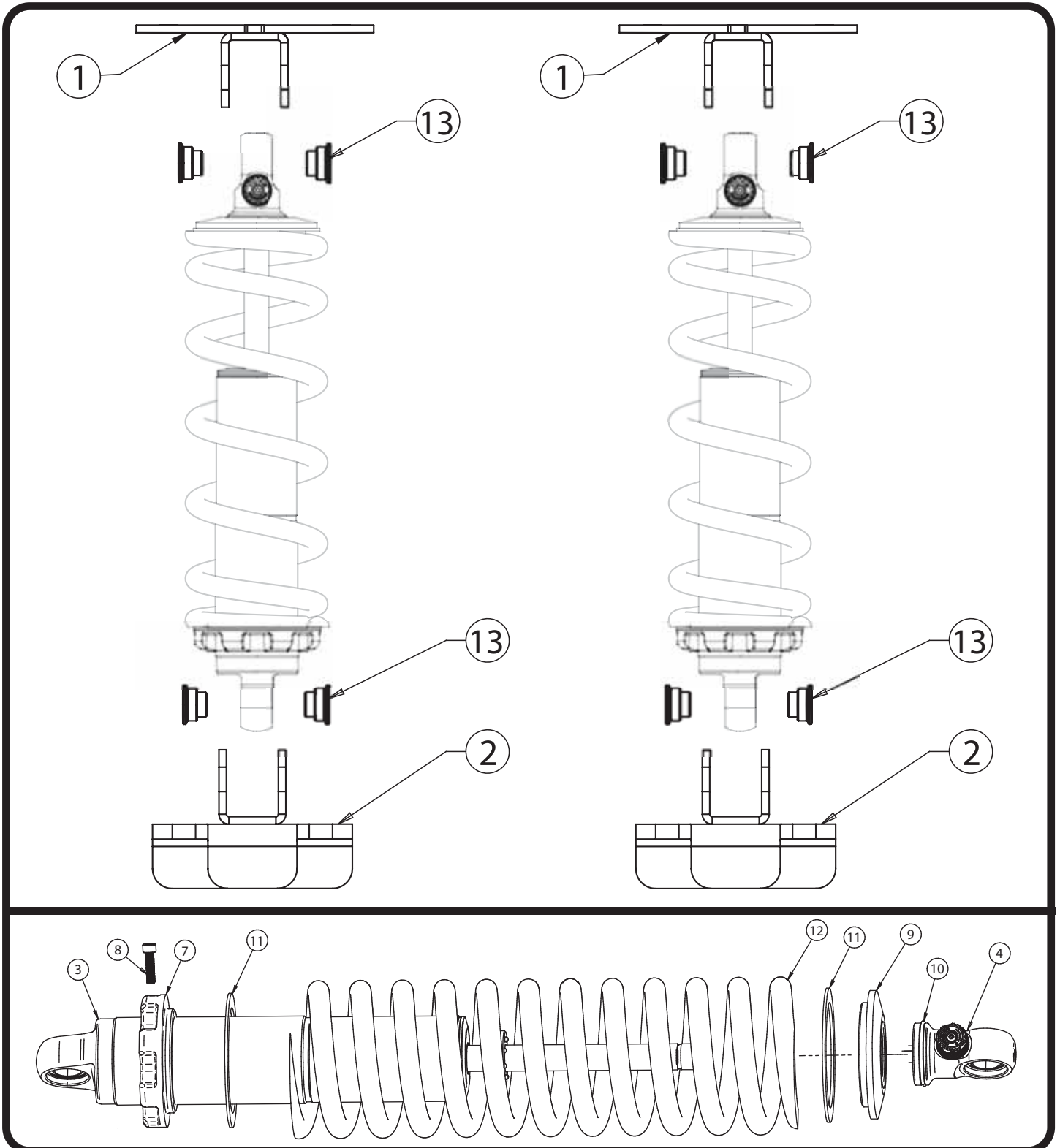



Alignment Note.....

THE LOWER YOU SET THE FRONT RIDE HEIGHT OF YOUR SILVERADO, THE HARDER IT WILL BE TO GET AN ALIGNMENT THAT IS WITHIN SPECIFICATIONS.

Disassembly

This CoilOver System is Designed to replace the factory Shocks and Springs.

The front OEM Shock and Spring assemblies will need to be removed from the front of the truck. **DO NOT DISASSEMBLE THE SHOCK/SPRING ASSEMBLY.**

1. Raise the vehicle and support it by the frame, allowing the suspension to hang freely.
2. Remove the shock/spring assembly from both sides of the truck.
3. If replacing the OEM spindles, remove them at this time (refer to pages 11-12).

Getting Started.....

4. The CoilOvers need to be assembled before putting the shocks in the mounts. Assemble the shocks and springs using the instructions below.

NOTE: The Upper and Lower Mounts are not side specific so they are the same for both sides of the truck.

CoilOver Assembly...



1

First, using the supplied lower adjuster nut (803-00-199) thread the nut onto the shock from the bottom side as seen in figure 1. Remove the plastic pellet that is in the split of the adjuster nut.



2

Next, install a delrin washer then coil spring over the top of the shock as seen in figure 2.



3

Before the upper spring mount can be installed screw the adjuster knob on the upper eye mount to the firmest setting (clockwise) as seen in figure 3. Then remove the Knob by holding it while removing the center screw.



4

Once the knob is removed slide a Delrin washer over the eyelet. Next, slide the upper spring mount (803-00-199) over eyelet as seen in figure 4.



5

Install upper spring mount retainer clip (803-00-199) into the groove on the upper eyelet as seen in figure 5. Then, reinstall adjuster to complete assembly.

Install the locking screw in the adjuster nut before setting spring preload, but DO NOT tighten until the spring preload has been set.

NOTE: Remember to adjust the shock valving before driving, the shock is currently set to full stiff.



Assembling CoilOver



5. Install the 1/2" I.D. bearing spacers into bearing in the shock body. These spacers have a through hole that is 1/2" diameter. The small diameter of the spacers will insert into the shock bearing.



6. Insert the shock into the Lower Mount. Line up the shock bearing/spacers hole with the mounting holes of the lower mount. Insert a 1/2"-13 x 2 3/4" bolt through the mount/shock. Install a 1/2" flat washer and 1/2"-13 nylok nut on the threads of the bolt that are sticking through the mount.



7. Install the 1/2" I.D. bearing spacers into bearing in the shock eyelet. These spacers have a through hole that is 1/2" diameter. The small diameter of the spacers will insert into the shock bearing.



Assembling CoilOver

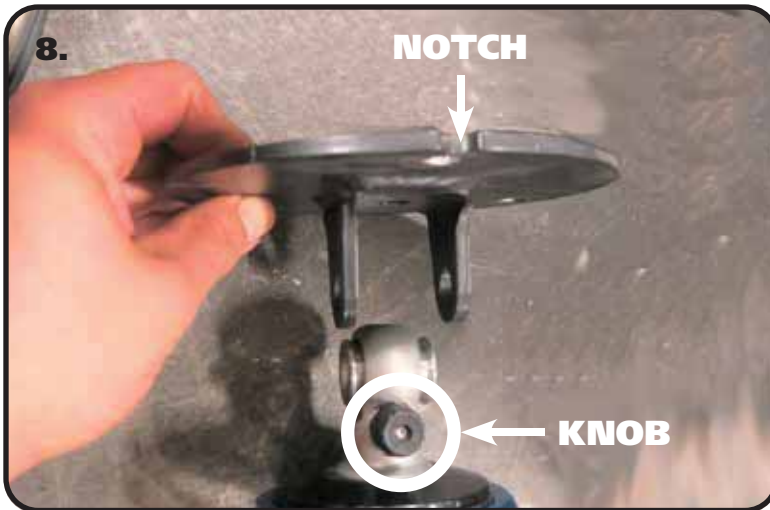

8. Attach the Upper Mount to the shock eye. The mount needs to be attached to the eyelet so that the notch is on the same side as the adjuster knob.



9. Insert the shock eyelet into the Upper Mount. Line up the shock bearing/spacers hole with the mounting holes of the upper mount. Insert a 1/2"-13 x 2 3/4" bolt through the mount/shock. Install a 1/2" flat washer and 1/2"-13 nylok nut on the threads of the bolt that are sticking through the mount. Torque the upper and lower mounting hardware to 75 ftlbs.



10. Your assembly should look like **Image 10**. The SHORT TAB of the lower mount should be on the same side as the NOTCH in the upper mount. If it is NOT, you can turn the upper mount by hand.



Installation of CoilOver Assembly



11. Put the CoilOver in position on the truck. The Lower Mount will only attach to the control arm one way. The SMALL vertical tab needs to be positioned toward the wheel.



12. The Upper Mount needs to be positioned with the NOTCH toward the wheel. The shock adjuster knob should also be toward the wheel.

NOTE: If the adjuster knob is not toward the wheel with the upper mount in the correct position, the upper mount will need to be removed from the eyelet and rotated 180°.



13. Align the mounting holes of the lower mount with the OEM shock mounting holes in the lower control arm. Install a 3/8" flat washer on each of (2) 3/8"-16 x 2 1/4" hex bolts. Insert the bolts/washers in the aligned holes of the lower mount and control arm.



CoilOver Assembly Installation



14. Install a 3/8" flat washer and 3/8"-16 nylok nut on the threads of the bolts sticking through the lower control arm. Torque the hardware to 45 ftlbs.



15. Install a 7/16" flat washer on each of (3) 7/16"-14x1 3/4" hexbolts. Align the mounting holes of the upper mount with the mounting holes in the frame. The mounting bolts need to be installed with the threads pointing up. Insert a bolt/washer in each holes. Install a 7/16" flat washer and 7/16"-14 nylok nut on the threads of each bolt sticking through the frame. Torque the hardware to 50 ftlbs.



16. Slide the wire loom clip on the threads of the front upper mounting bolt.

17. Repeat steps 4-16 on the other side of the truck. Preload the springs of the CoilOver 1/2" to start. You may need to adjust the amount of preload in the spring, but this will be determined after the truck has been sat on the ground. Refer to **Page 9** for spring adjustment.

18. If installing spindles, do so now.



CoilSpring & Shock Adjustment

Adjusting Spring Height

When assembling the CoilOver, screw the spring retainer tight up to the spring (0 preload). Measure from the bottom of the adjuster nut to the flat of the shock. Thread the adjuster up the shock 1/2" to preload the spring. Tighten the locking screw that is in the adjusting nut to lock the adjuster in place. After entire weight of truck is on the wheels, jounce the suspension and roll the truck forward and backward to alleviate suspension bind.

- If the truck is too high with 1/2" of preload, reduce the amount of preload that is on the spring by threading the adjusting nut down the shock body.
- If the truck is too low with 1/2" preload, then preload can then be added by threading the spring retainer up to achieve ride height.
- Lock the adjusting nut in place by tightening the locking screw that is the adjusting nut.

Part # 11709120 - 2007-2018 Silverado Front SwayBar (Optional, Purchased Separate)



Recommended Tools

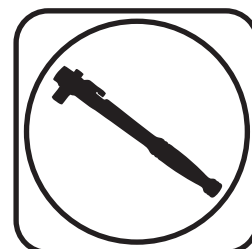
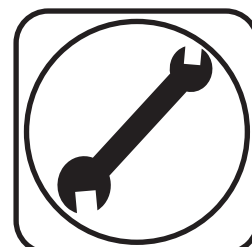

07-18 Silverado Front SwayBar Installation Instructions

Table of contents	
Page 20.....	Included Components and Hardware List
Page 20-22.....	SwayBar Installation

Hardware Torque Specifications	
M10-1.5.....	37 ftlbs
3/8"-16.....	30 ftlbs

www.ridetech.com 
 REV2 12/7/22

Major ComponentsIn the box

Part #	Description	QTY
90001376	Front Sway Bar	1
90001258	Sway Bar End Link T-Bushing	4
70015016	Lined Sway Bar Bushing	2
90001346	Bushing Strap	2
90001377	Bushing Mount Adapter	2
70014491	Locking Ring	2

END LINK ASSEMBLY

Part #	Description	QTY
90001379	90 Degree End Link Adapter	2
90002571	90 Degree End Link	2
99431026	7/16" -20 x 3" Hex Bolt	2
90002934	End Link Kit	1
99433010	7/16" Stainless Washer	4

HARDWARE KIT99010132

QTY	Part Number	Description
ADAPTER PLATE		
4	99111001	M10-1.5 x 30mm Flat Head
1	90002263	Red Loctite

QTY	Part Number	Description
BUSHING STRAP		
4	99372001	3/8"-16 Nylok Nut
4	99373002	3/8" SAE Flat Washer

Getting Started.....

This sway bar kit utilizes a anti-friction lining in the sway bar bushing. The lining allows the sway bar to move freely and quietly in the bushing. No lubrication is required.

1. Jack the vehicle up to a safe working height and support with jack stands. Make sure the jack stands are stable before working under the vehicle.

2. Remove the stock sway bar.



3. Open the sway bar bushing at the split and slide it **OVER** the swasy bar. Do this for both bushings.



4. Slip the Bushing Straps over the SwayBar Bushings.

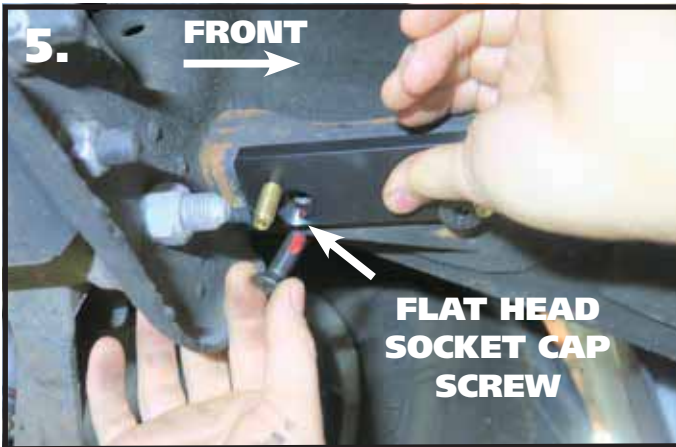

5. Hold the Frame Plate up to the OEM holes, the STUDS will need to be positioned to the CENTER of the truck. Apply Red Loctite to the M10-1.5 x 30mm Flat Head Bolts. Thread the bolts into the holes. Torque the bolts.

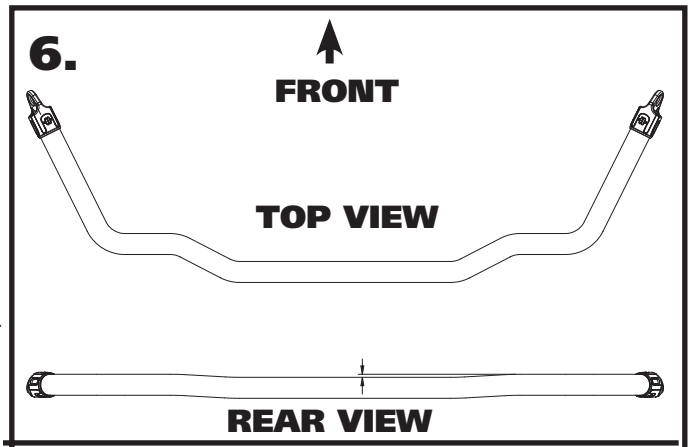

6. Image 6 illustrates the correct orientation of the swaybar. With the arms level, the center of the bar should be lower than the arms.



7. Slide the swaybar into position with the center of the bar being the lowest point. Slip the swaybar bushing straps onto the studs of the mounting plates.



8. Install a 3/8" flat washer and 3/8"-16 nylok nut on each of the 4 studs. Roughly center the bar and torque the nylok nuts.

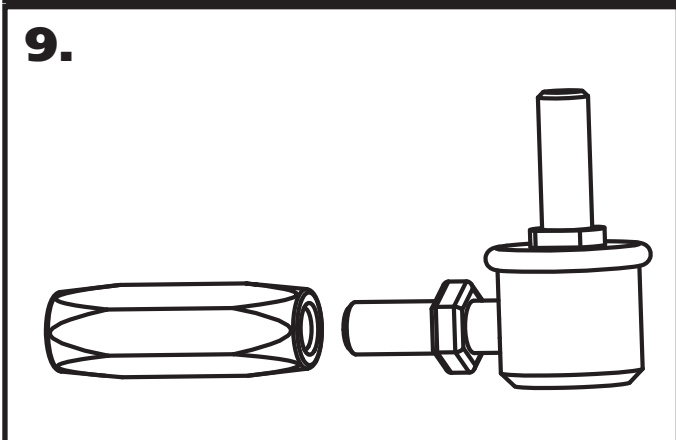

9. The swaybar end links will need to be partially assembled before they can be installed. Using your fingers, thread the jam nut all the way on until it stops. Thread the spacer onto the stud until it stops against the jam nut.

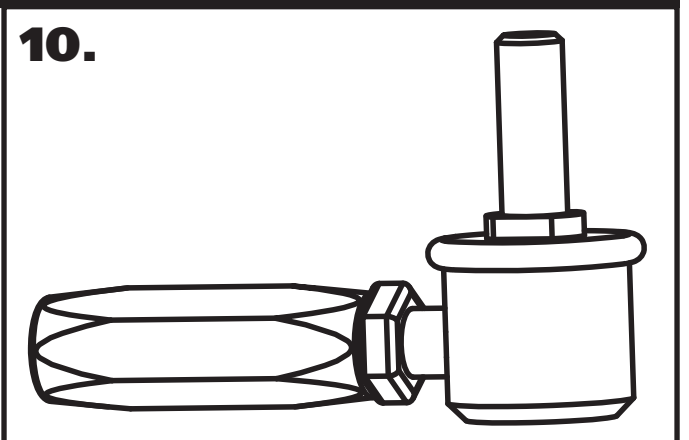

10. Use 2 wrenches to lock the jam nut against the spacer. Your assembly should look like **Diagram 10**.



11.

11. Install a T-Bushing on each of the 90 degree end links. The t-bushings are installed with the large diameter against the shoulder of the end link.



12.

12. Insert the 90 degree end link/t-bushing into the swaybar end with the threads pointing toward the center of the truck.



13.

13. Install a 2nd t-bushing with the small diameter into the swaybar.



14.

14. Install the nut that came supplied on the end and torque. Do this for both sides.

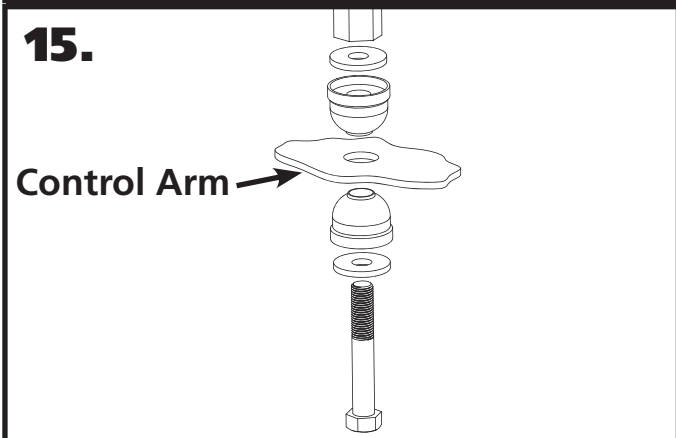

15. Install the End Links using **Diagram 15** as a reference. The supplied 7/16" -20 x 3" bolt is used to attach the end links to the control arm. Install both end links before tightening the end link hardware. Use the supplied Red Loctite on the bolt and tighten it until it bottoms out.



16.

16. Install the stop rings against the swaybar bushing. The stop rings will go against the inner side of the bushing. Take the stop rings apart and reassemble them against the bushing and tighten.



Part # 11707199 - 2007-2018 Silverado Rear Bolt-in 4 Link

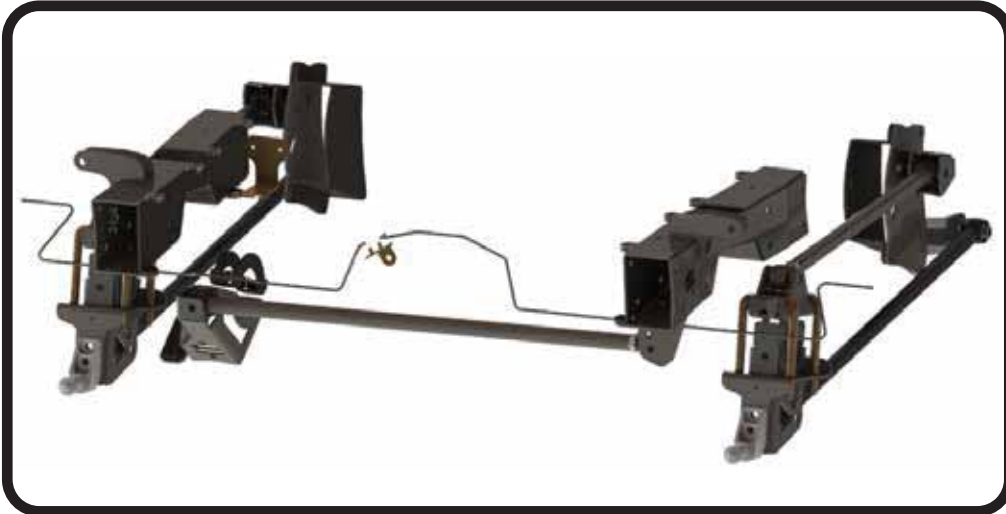

Recommended Tools

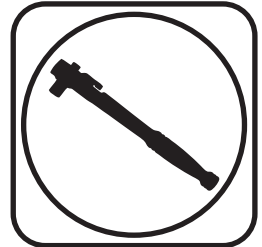

2007-2018 Silverado Rear Bolt-in 4 Link Installation Instructions

Table of contents

- Page 20-21..... Major Components List & Diagram
- Page 22..... Hardware List & R-Joint Information
- Page 23..... Getting Started
- Page 24-27..... Disassembly
- Page 27-34..... C-Notch Installation
- Page 34-37..... Upper Bar Mount Installation
- Page 37-40..... Axle Mount Installation
- Page 40-42..... Lower & Upper Bar Installation
- Page 43..... Lower Shock Mount Installation
- Page 43-45..... Panhard Mount Installation
- Page 45..... Panhard Bar Installation
- Page 46-47..... Shock Installation
- Page 48-49..... Brake Line Installation
- Page 50..... Bed Modifications
- Page 51-52..... Brake Line Bracket Install
- Page 54..... Bumpstop Installation





Major ComponentsIn the box

Item #	Part #	Description	QTY
1	90001406	Upper Bar Mount - Driver	1
2	90001407	Upper Bar Frame Mount Retainer Plate - Driver	1
3	90001408	Upper Bar Mount - Passenger	1
4	90001409	Upper Bar Frame Mount Retainer Plate - Passenger	1
5	90001410	Lower Axle Mount	2
6	90001411	Upper Axle Mount	2
7	90001412	Frame C-Notch - Driver	1
8	90001413	C-Notch Inner Plate - Driver	1
9	90001414	Frame C-Notch - Passenger	1
10	90001415	C-Notch Inner Plate - Passenger	1
11	90001416	Axle Panhard Mount	1
12	90001417	Axle Panhard Mount Axle Strap	1
13	90001418	Panhard Axle Mount Clamp Plate	1
14	90001419	Upper Bar - 24.210 center to center	2
15	90001420	Lower Bar - 32.700 center to center	2
16	90001421	Panhard Bar - 33.720 center to center	1
17	90001367	Brake Line Relocation Bracket	1
18	90001422	Brake Line Relocation Bracket	1
19	70013322	Short Bumpstop - NOT SHOWN	2
20	90001624	Aluminum Lower Shock Mount	2
21	99622005	U-Bolt 5/8-18 3.13W x 6.06L, Square Shoulder	4
22	90001318	RH R-Joint Threaded Housing End (installed in bars)	5
23	70013949	R-Joint Spacer - .500 ID x .620" (Pair = 1.740" Total Width)	4
24	70013882	R-Joint Spacer - .625 ID x .740" (Pair = 1.980" Total Width)	12
25	70013408	R-Joint Spacer - .625 ID x 1.120" (Pair = 2.740" Total Width)	4
26	90002067	Aluminum Shock Bearing Spacer - Lower - .625" x .450" Long	4
27	70002825	Lower Shock Stud	2
28	99752004	3/4"-16 Jam Nut - installed on R-Joint ends	5
29	70014892	Axle Brake Line - Driver	1
30	70014889	Axle Brake Line - Passenger	1
31	70014885	Driver C-Notch Template - NOT SHOWN	2
32	70014886	Passenger C-Notch Template - NOT SHOWN	2
R-Joint Components - (Installed in bar ends)			
	70013279	Retaining Ring	5
	70013280	Wavo Wave Spring	5
	70013275	R-Joint Center Ball	5
	70013276	R-Joint Composite Center Ball Cage	5



Part Diagram

PASSENGER

DRIVER

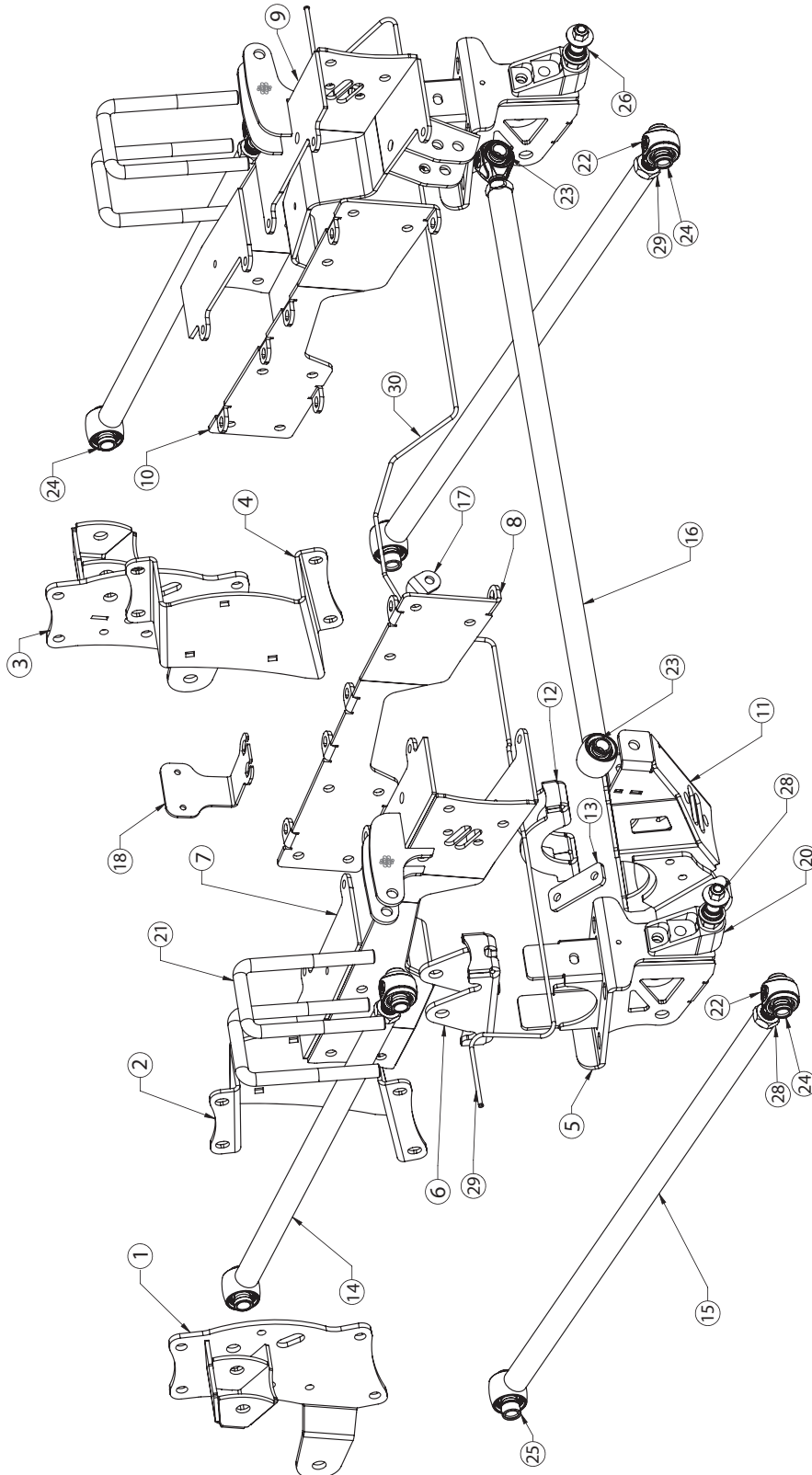



Hardware ListIn the box (Kit# 99010155)

The 4-Link Kit is supplied with a hardware kit. This hardware kit contains individual bags for the different parts of the installation. The bags are labeled to help determine the correct hardware for the installation of the specific parts of the kit. The instructions will aid you in selecting the correct hardware during the installation.

C-Notches		QTY
99431028	7/16-14 X 4 IN GR. 8 HEX BOLT	8
99431029	7/16-14 X 4.5 IN GR. 8 HEX BOLT	6
99431030	7/16-14 X 5.5 IN GR. 8 HEX BOLT	2
99433005	7/16 SAE FLAT WASHER GR8	36
99432010	7/16-14 NYLOK NUT GR8	18
99371005	3/8-16 X 1.25 GR. 8 HEX BOLT	12
99373002	3/8 SAE FLAT WASHER GR. 8	24
99372001	3/8 -16 NYLOK NUT GR8	12
Frame Bar Mount		
99371070	3/8-16 X 4" CARRIAGE BOLT	6
99373002	3/8 SAE FLAT WASHER GR. 8	6
99372001	3/8 -16 NYLOK NUT GR8	6
99501053	1/2-13 X 1.5" GR. 8 HEX BOLT	8
99503014	1/2 SAE FLAT WASHER GR. 8	16
99502009	1/2-13 GR. 8 NYLOK NUT	8
Axle Lower Bar Mount		
99623001	5/8 SAE FLAT WASHER GR. 8	8
99622001	5/8-18 NYLOK NUT GR 8	8
Lower Bars		
99623001	5/8 SAE FLAT WASHER GR. 8	8
99622006	5/8-18 NYLOK JAM NUT	2
99622001	5/8-18 NYLOK NUT GR 8	2
99621015	5/8-18-4.5" GR. 8 HEX BOLT	2
99621018	5/8-18X 3.25" GR. 8 HEX BOLT	2
Upper Bars		
99621018	5/8-18X 3.25" GR. 8 HEX BOLT	4
99623001	5/8 SAE FLAT WASHER GR. 8	8
99622006	5/8-18 NYLOK JAM NUT	4

Panhard Bar		QTY
99503014	1/2 SAE FLAT WASHER GR. 8	4
99502009	1/2-13 GR. 8 NYLOK NUT	2
99501004	1/2-13 X 3" GR. 8 HEX BOLT	2
Panhard Bar Axle Mount		
99371007	3/8-16 X 1.5 GR. 8 HEX BOLT	4
99372001	3/8 -16 NYLOK NUT GR8	4
99373002	3/8 SAE FLAT WASHER GR. 8	8
99501069	1/2-13 X 1.75" GR. 8 HEX BOLT	2
99502009	1/2-13 GR. 8 NYLOK NUT	2
99503014	1/2 SAE FLAT WASHER GR. 8	4
Rear Shock Mounts		
99501007	1/2-20 X 1.25 GR. 8 HEX BOLT	2
99501009	1/2-20 X 1.75" GR. 8 HEX BOLT	2
99501011	1/2-20 X 2.5 GR. 8 HEX BOLT	2
99502002	1/2-20 GR. 8 NYLOK NUT	6
99503014	1/2 SAE FLAT WASHER GR. 8	8
Shock Stud		
99432002	7/16"-20 NYLOK NUT	2
99433002	7/16" SAE FLAT WASHER	2
99623004	5/8" SAE FLAT WASHER	2
Brake Line Brackets		
99311001	5/16-18 X 1 Hex Cap Screw GR 5	1
99312003	5/16-18 NYLON INSERT L/N ZINC	1
99313002	5/16 SAE FLAT WASHER ZINC	3
99081007	M8-1.25 X 20mm HEX CAP SCREW	1
99101009	#10 x 3/4" SELF DRILLING SCREW	2

R-Joint Information

R-JOINT SPACER INSTALLATION

Install the Spacers by inserting the SMALL side of the SPACER into the Center Pivot Ball. Push them in until they bottom out and stop.

ALL R-JOINTS

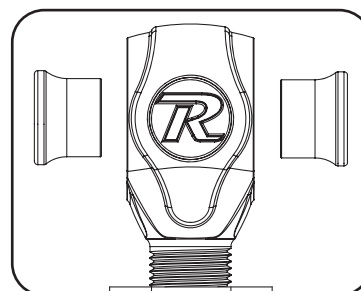

New R-Joints will be quite stiff (75-90 in/lbs breakaway torque) until they "break in" after a few miles of use. After the break in period they will move much more freely. Because the composite bearing race contains self lubricating ingredients, no additional lubrication is needed or desired. Any additional lubrication will only serve to attract more dirt and debris to the R-Joint and actually shorten its life.



Getting Started.....

Congratulations on your purchase of the Ridetech Rear 4-link System. This system has been designed to give your Silverado excellent handling along with a lifetime of enjoyment. This system provides tunability, replaces the leaf springs, and allows the 4-Link to locate the rearend and the CoilOvers/ShockWaves to support the truck

Note: This system is designed for use with the Ridetech Shockwaves or CoilOvers. **The factory shocks and springs will not fit this setup.**

**THE BED AND FUEL TANK WILL NEED TO BE REMOVED TO INSTALL THIS 4-LINK SYSTEM!
NEW REAR AXLE BRAKE LINES ARE INCLUDED IN THIS KIT. YOU WILL NEED TO BLEED THE
BRAKES AFTER INSTALLING THIS KIT!**

THE EXHAUST TAILPIPE MAY NEED MODIFIED TO CLEAR THE NEW REAR SUSPENSION.

1. Raise the vehicle to a safe and comfortable working height. Use jack stands to support the vehicle with the suspension hanging freely.
2. Support the axle and remove the leaf springs, shocks and tail pipes. Refer to the factory service manual for proper disassembly procedures. The rear seat will also need to be removed.

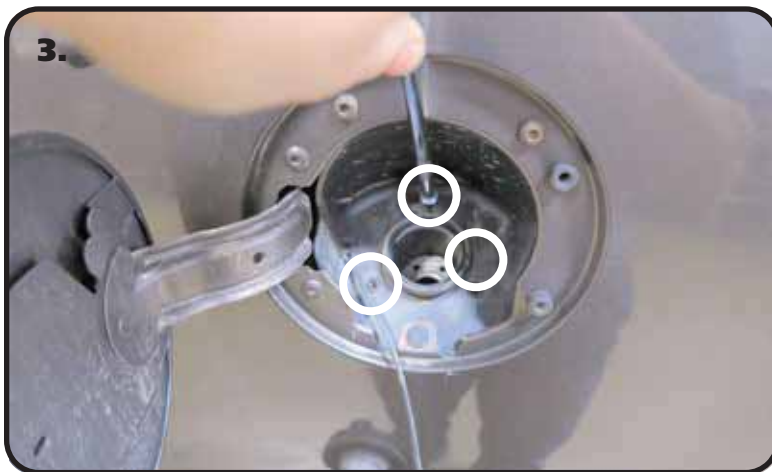

3. The bed will need to be removed to install this kit. Start by removing the (3) screws around the filler neck. The 3 screws are circled in **Image 3**.



4. Remove the hardware that attaches the bed to the frame. Unplug the tail light wiring from the rear distribution block. We suggest recruiting a few friends to lift the bed off the truck. You will want to position the bed in a way that you have access to the bottom of the bed for later modifications.



Disassembly



5. Remove the solenoid from the rear corner of the fuel tank. Remove the solenoid by releasing the locking tab and sliding it off the bracket.

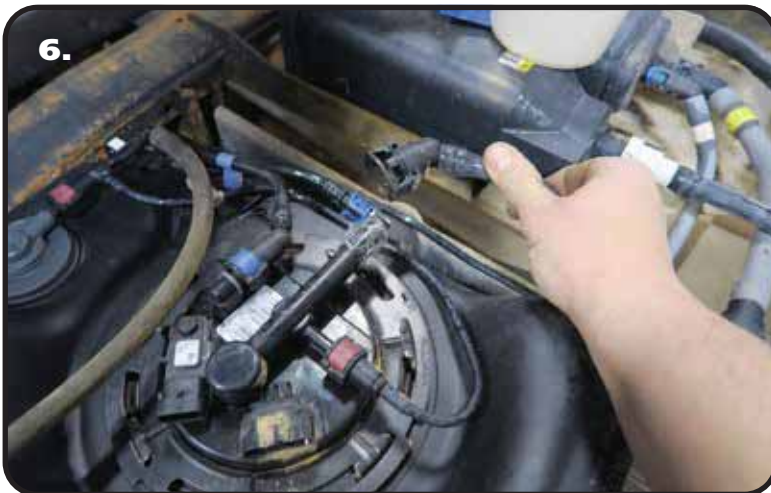

6. Disconnect the lines from the top of the fuel pump module.

COVER THE ENDS OF THE LINES TO PROTECT THEM!



7. Disconnect the wires from the top of the fuel pump module.



Disassembly



8. Some of the lines have a lock. It will need to be disengaged to remove the lines.



9. Unbolt the filler neck ground wire from the front side of the front bed mount.



10. Remove the gas tank shield hardware and remove the gas tank shield.



Disassembly



11. Support the center of the fuel tank before removing the gas tank straps. We use a transmission jack to support it. Remove the gas tank strap hardware and straps. Slowly lower the gas tank.



12. Remove the brake line retainer from the top of the driver frame rail.



13. Remove the ABS sensor wire from the top of the driver frame rail.



Disassembly & C-Notch Installation



14. Unbolt the brake line bracket from the top of the driver frame rail.



15. Unbolt the front emergency brake cable bracket from the driver frame rail. Retain the hardware for later reinstallation.



16. Unbolt the rear emergency brake cable bracket from the driver frame rail. Retain the hardware for later reinstallation.



C-Notch Installation



17. To allow maximum drop on this truck, the frame must be notched. The kit includes templates to cut the outside and inside of the frame. The template for the notch will locate off of the large oval hole and top of the frame rail. Start by cutting the large oval hole out of the template. **DO NOT CUT THE NOTCH AREA OF THE TEMPLATE AT THIS TIME.** Line up the large hole of the template with the hole in the frame. At the same time, line the template up with the top of the frame and tape it in place.

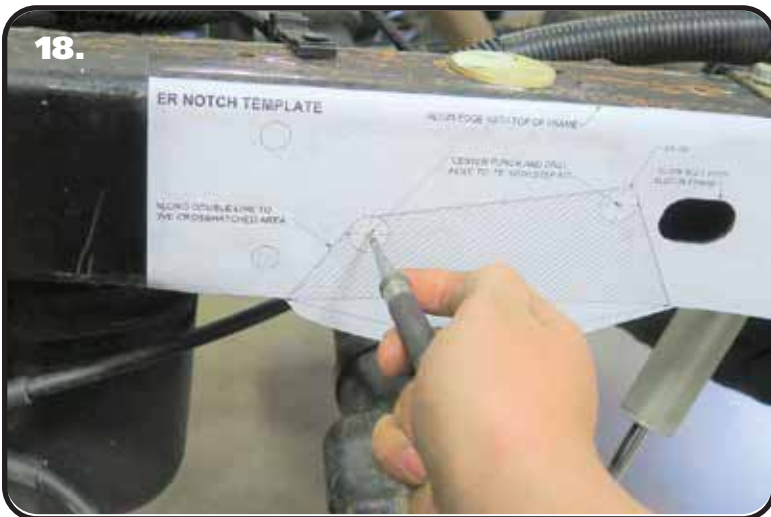

18. Center punch the drill marks of the c-notch corners.



19. We suggest drilling the corner holes with a smaller drill bit first.



C-Notch Installation

20.

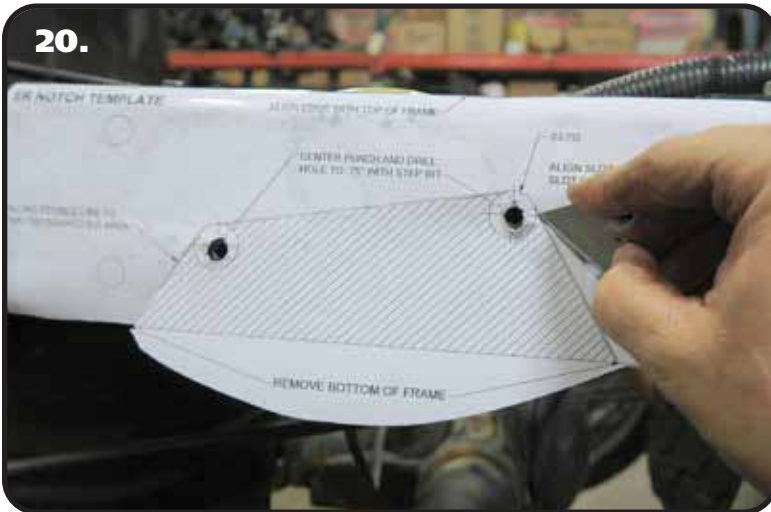

20. Use a razor blade to cut out the hashed area of the template.

21.



21. Trace along the area you just cut out.

22.



22. The corners will get drilled out to 3/4". A unibit works good for this.



C-Notch Installation



17. To allow maximum drop on this truck, the frame must be notched. The kit includes templates to cut the outside and inside of the frame. The template for the notch will locate off of the large oval hole and top of the frame rail. Start by cutting the large oval hole out of the template. **DO NOT CUT THE NOTCH AREA OF THE TEMPLATE AT THIS TIME.** Line up the large hole of the template with the hole in the frame. At the same time, line the template up with the top of the frame and tape it in place.

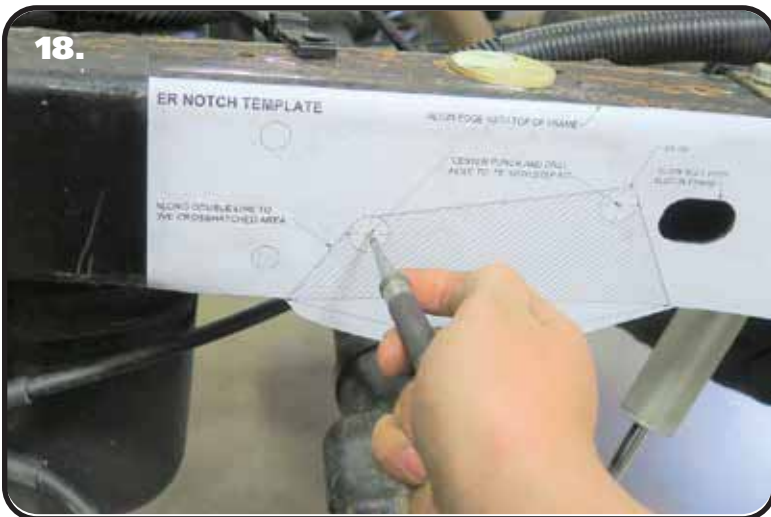

18. Center punch the drill marks of the c-notch corners.



19. We suggest drilling the corner holes with a smaller drill bit first.



C-Notch Installation

20.

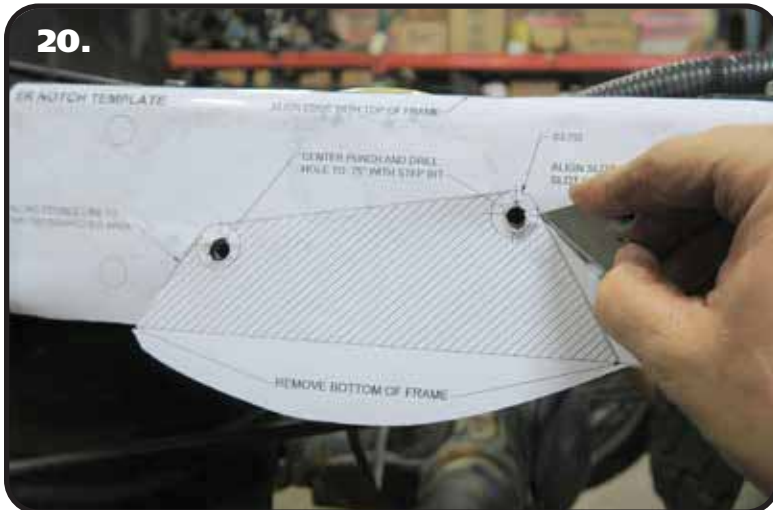

20. Use a razor blade to cut out the hashed area of the template.

21.



21. Trace along the area you just cut out.

22.



22. The corners will get drilled out to 3/4". A unibit works good for this.



C-Notch Installation



23. Remove the template and cut the line you just traced.



24. Repeat **Steps 17-23** on the inside of the frame rail.



25. You will have to cut across the bottom of the frame rail, connecting the inner and outer cuts. At this point you should be able to remove the section of frame rail.



C-Notch Installation



26. The c-notch will have a snug fit on the frame rail and will most likely need tapped in place with a dead blow hammer.



27. Position the inner c-notch plate flat against the inside of the frame with the bolt tabs away from the frame. The bolt tabs will line up with the tabs on the outer c-notch.



28. Install a 3/8" flat washer on each of (6) 3/8"-16 x 1 1/4" hex bolts. Insert a bolt/washer in each of the bolt tabs.



C-Notch Installation



29. Install a 3/8" flat washer and 3/8"-16 nylok nut on each of the (6) bolts. Torque to 45 ftlbs.



30. Using the c-notch as a template, drill the (7) holes in the outside of the frame rail using a 7/16" drill bit.



31. Using the inner c-notch plate as a template, drill the (7) holes in the inside of the frame rail using a 7/16" drill bit.



C-Notch Installation

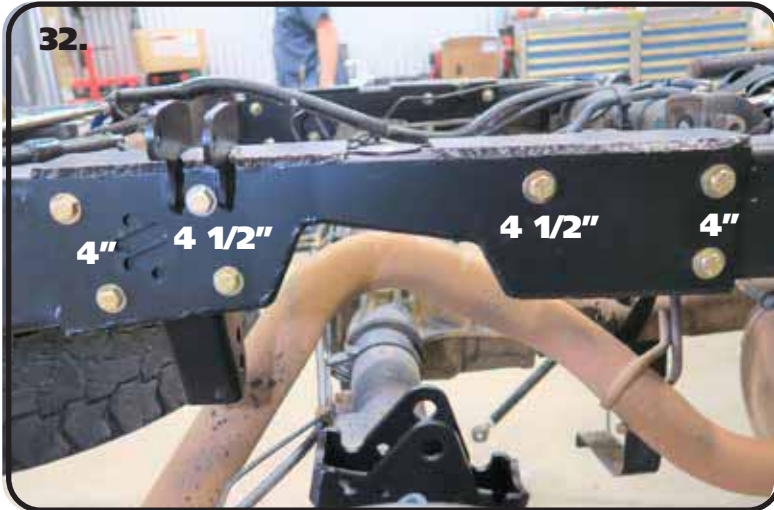

32. The c-notch uses 2 different lengths of bolts to bolt through the frame rail. The 2 front and 2 rear holes use 7/16"-14 x 4" hex bolts. The 4 middle holes use 7/16"-14 x 4 1/2" hex bolts. Install a 3/8" flat washer on each of (4) 7/16"-14 x 4" hex bolts and (3) 7/16"-14 x 4 1/2" hex bolts. Insert the bolts through the outer c-notch until they stick through the inner c-notch plate. **Image 32** illustrates the location and lengths of the bolts,



33. Install a 7/16" flat washer & 7/16"-14 nylok nut on the threads of the bolts sticking out of the inner c-notch plate. Torque to 70 ftlbs.



34. The c-notches require one hole to be drilled through the top and bottom of the frame rail. This hole is located behind the shock mount. Use the c-notch as a template to drill the hole in the top of the frame rail using a 7/16" drill bit.



Upper Bar Mount Installation



41. Install a 1/2" flat washer on each of (4) 1/2"-13 x 1 1/2" hex bolts. Insert the bolt/washer through the (2) top holes & (2) bottom holes of the outer mount and inner retainer. Install a 1/2" flat washer & 1/2"-13 nylok nut on each of the (4) bolts. Torque to 80 ftlbs.



42. Drill the (3) outer holes that are BLACKED OUT in **Image 37** using a 3/8" drill bit. Use the outer mount as a template.



43. Drill the (3) inner holes that are BLACKED OUT in **Image 37** using a 3/8" drill bit. Use the inner retainer as a template.



Upper Bar Mount & Axle Mount Installation



44. Install the (3) 3/8"-16 x 4" carriage bolts from the **INSIDE** of the frame with the threads sticking through the outer mount. Make sure the square shoulders of the carriage bolts are engaged into the square openings of the inner retainer.



45. Install a 3/8" flat washer and 3/8"-16 nylok nut on each of the (3) bolts. Torque to 30 ftlbs. Remove the 5/8"-18 x 4 1/2" bolt from the front leaf spring mount that was used to locate the mount.

REPEAT STEPS 37 - 45 ON THE OTHER SIDE. THE PASSENGER SIDE WILL NOT HAVE A EMERGENCY BRAKE CABLE BRACKET BOLT.



46. Remove the bolt from the brake line retainer. The brake line retainer bolts to the bracket that is on the rear side of the leaf spring perch. Remove these from both sides of the axle.



Axle Mount Installation

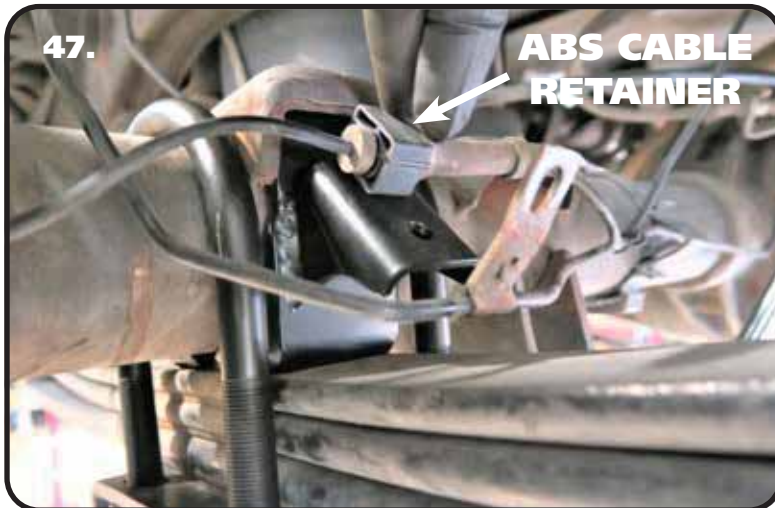

47. Remove the ABS cable from the retainer that is attached to the same bracket as the brake line retainer. Remove the ABS cable retainer from the bracket. These will be reinstalled later.



48. The bracket that is at the rear of the OEM leaf spring perch will need to be cut off of the axle tube. We use a saw-z-all to cut it off. It needs to be cut off even with the axle, perpendicular to the top of the leaf spring perch. Use **Images 48 & 49** as a reference.



49. **Image 49** illustrates the bracket cut off. Again, we use a saw-z-all to cut it off.



Axle Mount Installation



50. Sit the upper bar mount on the leaf spring pad of the axle. The locating pin needs to insert into the leaf spring locating hole of the leaf spring pad. The upper bar mounts are the same for driver and passenger sides.



51. Install a supplied 5/8" u-bolt in each side of the upper bar mount. The u-bolts will nest in the front and rear slots of the upper mount.



52. The lower axle mounts are the same for driver and passenger sides. Slide an axle mount on the U-bolts with the top tabs inserted into the leaf spring pad.



Axle Mount & Lower Bars Installation



53. Hold the mount in place and install a 5/8" flat washer and 5/8" high nut on the threads of the u-bolts sticking through the axle mount. Tighten the nuts evenly in a criss-cross fashion making sure the tabs of the axle mount are touching the leaf spring pad evenly. Torque the nuts in a criss-cross fashion to 60 ftlbs. Repeat on the other side.



54. Insert the .625" ID x 1.120" long R-Joint spacers into the front of the lower bar (32.700"). The small diameter of the spacer goes into the R-Joint. Insert the front lower bar R-Joint into the front leaf spring mount.



55. Line the through hole of the R-Joint with the holes of the leaf spring mount. Install a 5/8" flat washer on to a 5/8"-18 x 4.5" hex bolt, insert into the lined up holes. Install a 5/8" flat washer followed by a 5/8"-18 THIN nylok nut. Repeat on both sides and tighten the bolts/nuts enough to eliminate any gaps.



Lower & Upper Bars Installation



56. Insert (2) .625" ID x .740" long R-Joint spacers into the R-Joint of one end of each lower bar. The small diameter of the spacer goes into the R-Joint. Insert the rear of the lower bar R-Joint into the lower axle bracket.



57. Line the through hole of the R-Joint with the holes of the axle bracket. Install a 5/8" flat washer on to a 5/8"-18 x 3 1/4" hex bolt, insert into the lined up holes. Install a 5/8" flat washer followed by a 5/8"-18 THIN nylok nut. Repeat on both sides and tighten the bolts/nuts enough to eliminate any gaps.



58. Insert (2) .625" ID x .740" long R-Joint spacers into the R-Joint of one end of each upper bar (24.210"). The small diameter of the spacer goes into the R-Joint. Insert the front upper bar R-Joint into the upper bar mount.



Upper Bars Installation



59. Line the through hole of the R-Joint with the holes of the bar mount. Install a 5/8" flat washer on to a 5/8"-18 x 3 1/4" Hex bolt, insert into the lined up holes. Install a 5/8" flat washer followed by a 5/8"-18 THIN nylok nut. Repeat on both sides and tighten the bolts/nuts enough to eliminate any gaps.



60. Insert (2) .625" ID x .740" long R-Joint spacers into the rear R-Joint of each upper bar. The small diameter of the spacer goes into the R-Joint. Insert the rear upper bar R-Joint into the upper axle bracket.



61. Line the through hole of the R-Joint with the holes of the axle bracket. Install a 5/8" flat washer on to a 5/8"-18 x 3 1/4" hex bolt, insert into the lined up holes. Install a 5/8" flat washer followed by a 5/8"-18 THIN nylok nut. Repeat on both sides and tighten the bolts/nuts enough to eliminate any gaps.



Shock & Panhard Mount Installation



62. The lower shock mount attaches with (1) 1/2"-13 x 1 1/4" hex bolt, (1) 1/3"-13 x 1 3/4" hex bolt, & (4) 1/2" flat washers, & (2) 1/2"-13 nylok nuts. The lower mount gets attached to the TOP 2 HOLES of the axle mount. When the shock mount is installed correctly, the bottom of the lower shock mount is 1/8" above the bottom of the axle mount. Install a 1/2" flat washer on each bolt. Insert the bolts through the aluminum shock mount with the 1 1/4" long bolt in the top hole, 1 3/4" in the bottom hole. Insert the bolts through the axle mount and install the flat washers & nylok nuts on the threads sticking through. Repeat on both sides and torque the bolts/nuts to 75 ftlbs.



63. Steps 63-68 cover the installation of the axle panhard mount. The mount will sit against the inside of the driver OEM shock mount. The outer tab will sit against the bottom of the OEM shock mount.



64. You will need to drill (2) holes in the side of the OEM shock mount. Hold the panhard mount in position to mark these holes. Drill the 2 holes with a 3/8" drill bit.



Panhard Mount Installation



65. Install a 3/8" flat washer on each of (2) 3/8"-16 x 1 1/2" hex bolts. Hold the panhard mount in position and insert the bolt/washers through the mount and drilled holes. Install a 3/8" flat washer & 3/8"-16 nylok nut on each of the bolts. Do not tighten the hardware at this time.



66. Insert the (2) hole backer plate in the OEM shock mount. The hole of the backer will line up with the (2) holes of the panhard mount tab. Install a 3/8" flat washer on each of (2) 3/8"-16 x 1 1/2" hex bolts. Insert the bolts through the locating tab, through the slot in the OEM shock mount, and through the backer plate. Install a 3/8" flat washer & 3/8"-16 nylok nut on each of the bolts. Do not tighten the hardware at this time.



67. Position the panhard mount axle clamp on the front side of the axle tube, aligning it with the panhard mount that is already in position.



Panhard Mount & Panhard Bar Installation



68. Install a 1/2" SAE flat washer on each of (2) 1/2"-13 x 1 3/4" bolts. Insert the bolt/washers in the top and bottom mounting holes of the clamp/mount. Install a 1/2" SAE flat washer and 1/2"-13 nylok nut on the threads of each bolt. Torque these bolts to 75 ftlbs. You can now torque the 3/8" hardware that was installed previously. Torque the 3/8" hardware to 45 ftlbs.



69. Insert (2) .500" ID x .620" long R-Joint spacers into the R-Joint of one end of the panhard bar (33.720"). The small diameter of the spacer goes into the R-Joint. Insert the panhard bar R-Joint into the panhard mount that is on the axle. Line the through hole of the R-Joint with the holes of the panhard bracket. Install a 1/2" flat washer on to a 1/2"-13 x 3 1/4" hex bolt, insert into the lined up holes. Install a 1/2" flat washer followed by a 1/2"-13 nylok nut. Tighten the bolts/nuts enough to eliminate any gaps.



70. Insert (2) .500" ID x .620" long R-Joint spacers into the R-joint in the other end of the panhard bar. The small diameter of the spacer goes into the R-Joint. Insert the panhard bar R-Joint into the panhard mount that is on the passenger c-notch.

NOTE: The panhard mount has 2 sets of mounting holes to help set the panhard bar as level as possible depending on your ride height. We start out in the bottom hole.



Shock Installation



71. Line up the through hole of the R-Joint with the bottom holes of the panhard bracket. Install a 1/2" flat washer on to a 1/2"-13 x 3 1/4" hex bolt, insert into the lined up holes. Install a 1/2" flat washer followed by a 1/2"-13 nylok nut. Tighten the bolts/nuts enough to eliminate any gaps.

Note: Steps 72-75 cover the CoilOver/ ShockWave installation. CoilOvers can be installed with the shock body up or down. ShockWaves **must** be installed with the shock body down.



72. Ridetech CoilOvers or ShockWaves require a spacer on each side of the bearing. The upper shock uses a 1/2" ID spacer that is 3/8" long (90002043). The overall width with a spacer on each side will be 1 1/4". **The small side of the spacer goes into the shock bearing.**



73. Insert the Shock with the 1/2" ID Spacers into the shock mount. Install a 1/2" flat washer on a 1/2"-2- x 2 1/2" hex bolt. Line up the holes in the mount with the spacers and shock bearing. Insert the bolt/washer into the lined up holes. Install a 1/2" flat washer & 1/2"-20 Nylok Nut. Torque to 75 ftlbs

Note: If installing Shockwaves and you want to locate the air fitting in a different location, the air spring assembly can be rotated on the shock by grabbing the shock and air spring assembly by hand and spinning the shock in the air spring assembly.



Shock & Brake Line Installation



74. Install a 5/8" flat washer onto the 5/8"-18 threads of the shock stud. Apply Red Loctite to the 5/8" threads of the stud. Thread the shock stud into the threaded hole of the lower mount. Repeat on both sides and torque the shock stud to 65-75 ftlbs. The shock stud requires spacers that are .400" long (90002067). Install a 5/8" ID 90002067 spacer (**small side towards shock body**) onto the lower shock stud. Slide the bottom of the shock onto the stud. Install a second 5/8" ID 90002067 Spacer onto the stud (**small side towards shock**). You may need to jack the rear end up to slide the shock onto the Stud.



75. Install the 7/16" flat washer and 7/16" nylok nut. Tighten the upper and lower shock bolts. Torque the upper bolt to 50 ftlbs and the lower nut to 40 ftlbs. The designed ride height of the CoilOver/Shockwave is 14 1/2" center to center.



76a & 76b. Your truck could have 2 different brake line setups depending on the brake package the truck came with. **Images 76a & 76b** show each setup. This does not affect the mounting of the brake bracket. Remove the OEM brake line bracket that attaches to the differential cover bolt and brake line mount. Attach the new brake line bracket to the differential using the supplied M8-1.25 x 20mm bolt and 5/16" flat washer. Attach the brake line mount to the new brake line tab using (1) 5/16"-18 x 1" bolt, (1) 5/16"-18 nylok nut, and (2) 5/16" flat washers. Torque the M8 to 225 inlbs and the 5/16" to 17 ftlbs.



Brake Line Installation

76b.



76b. This is the other brake line possibility. Remove the OEM brake line bracket that attaches to the differential cover bolt and brake line mount. Attach the new brake line bracket to the differential using the supplied M8-1.25 x 20mm bolt and 5/16" flat washer. Attach the brake line mount to the new brake line tab using (1) 5/16"-18 x 1" bolt, (1) 5/16"-18 nylok nut, and (2) 5/16" flat washers. Torque the M8 to 225 inlbs and the 5/16" to 17 ftlbs.

77.



77. The kit includes new brake lines for the rear axle. We recommend removing and installing (1) brake line at a time. Start by removing the plastic brake line clamps from the axle tubes.

NOTE: The new supplied brake lines are designed to be compatible with drum brakes. If you have or will be running disc brakes, an extra bend will need to be added to the supplied brake lines as shown on the right side in Figure 79 on the next page.

78.



78. Remove the bolt from the clamp on the passenger axle tube. Retain the bolt for installation of the new brake line. The brake line clamp that is on the OEM line will need to be removed to be reinstalled on the new brake line.



Brake Line Installation



79. Remove the OEM brake line from the wheel cylinder using a line wrench.

NOTE: If you have or will be running disc brakes, an extra bend will need to be added to the supplied brake lines as shown on the right side in Figure 79.



80. Remove the opposite end that is threaded into the rubber hose. Replace the line with the new one supplied. Replace the other axle brake line. Use a line wrench to tighten the brake lines. Reinstall all of the clamps that were removed previously.

NOTE: If your truck has a single rubber line attaching to the axle, see **Step 81**.



81. If your truck has a single rubber line attached to the axle, you will need to tweak the end of the brake line to thread it into the hose end.

REINSTALL THE GAS TANK IN REVERSE ORDER OF REMOVING IT.



Bed Modifications

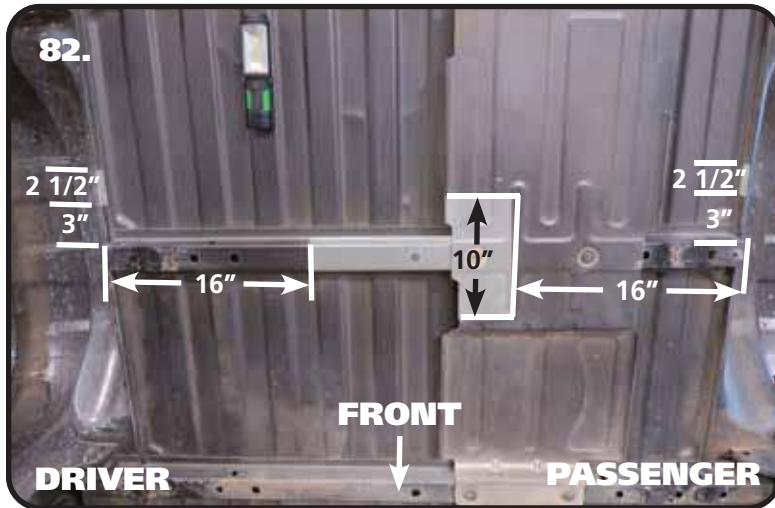

82. Trimming of the bed brace that is in between the wheel wells is necessary to clear the c-notches. The inside fender well lip will need to be cut to clear the shock mount. We cut ours with a die-grinder. **Image 82** shows the areas that will need cut out. **Step 83** covers the notching of the heat shield and bed brace. **Step 84** covers the cutting of the fender well lip.

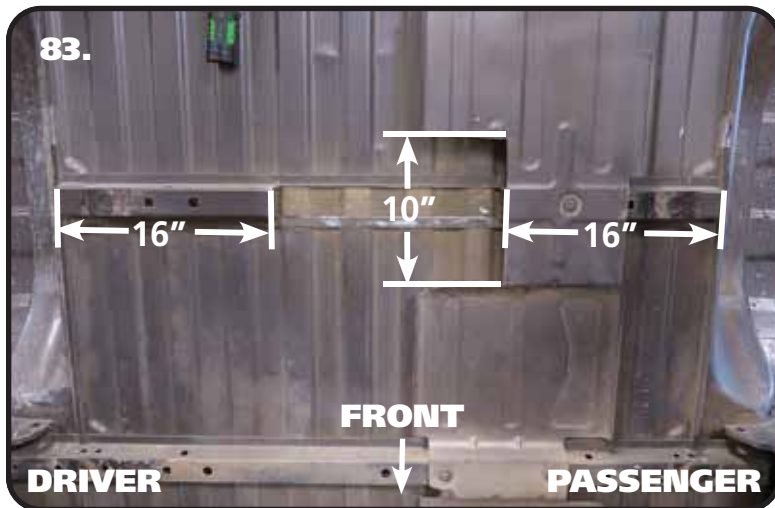

83. The bed brace cut starts 16" from each end of the bed brace. The heat shield on the passenger side will need notched for axle clearance. It is notched 5" forward and back from the center of the bed brace. Cut the bed brace even with the bent flange that attaches it to the bed floor.

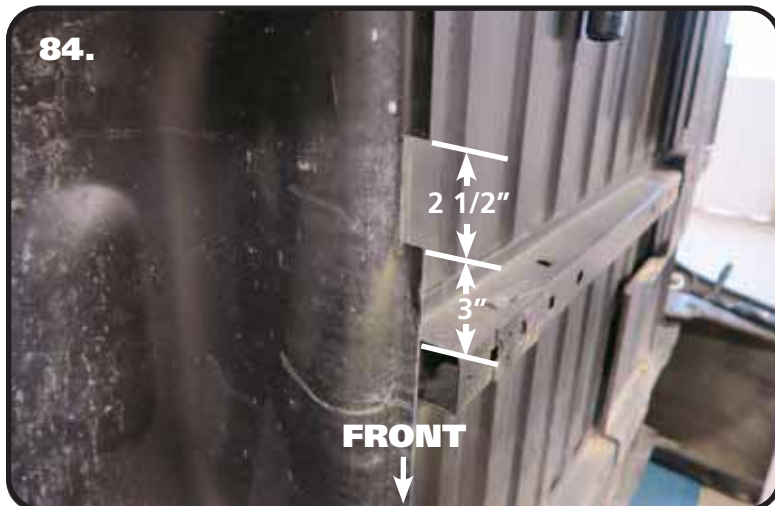

84. The inside fender well lip needs to be cut to clear the shock mount. The rear of the cut out is 3" behind the bed brace. The cut out needs to be 2 1/2" long.



Brake Line Bracket Install



85. The brake line bracket that bolted to the top of the driver frame rail will need to be replaced with one supplied in the kit. Start by loosening the lines using line wrenches.

Note: Your truck may only have one line attached to the bracket.



86. Remove the clips that hold the brake lines in place. Retain the clips for installation of the new bracket.



87. Separate the lines and remove them from the bracket. Threads the lines back together and tighten them using line wrenches. The new bracket has slots for the lines to slip through.

REINSTALL THE BED IN REVERSE ORDER OF REMOVING IT.



Brake Line Bracket & Bumpstop Install



88. Slip the brake line(s) into the new bracket and reinstall the clips. Screw the brake line bracket to the bed brace using the supplied #10 x 3/4" self drilling screws.



89. The c-notch openings above the axle are threaded to receive a bumpstop. Thread the bumpstops into the c-notches.

90. Bleed the rear brakes to eliminate any air that is in the system from having the brake lines open.

Be sure to check for any leaks after bleeding the brakes.

The designed ride height of the CoilOver/Shockwave is 14 1/2" center to center.

Double check all the hardware to ensure it is tight.



Part # 11706510 - 07-13 Silverado Rear HQ Series CoilOvers

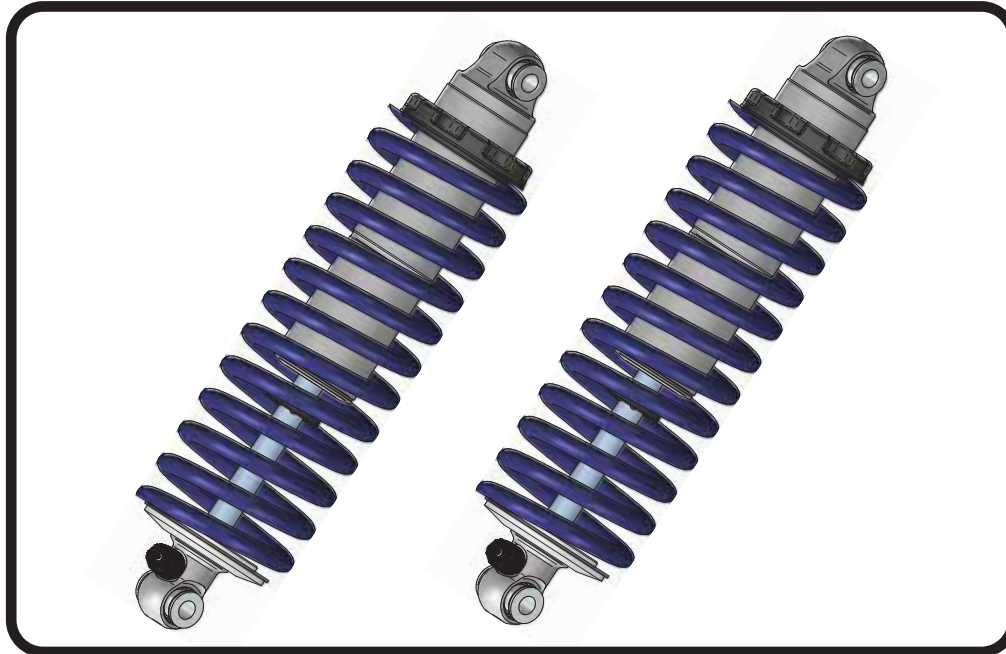

Recommended Tools

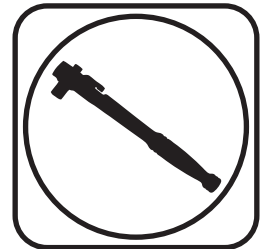

2007-2013 Silverado HQ Series Rear CoilOvers Installation Instructions

Table of contents

- Page 54..... Included Components
- Page 55..... Assembly and CoilSpring Adjusting
- Page 56-57..... Shock Adjustment

ShockWave Dimensions:

- Center of bearing to Center of bearing:
- Compressed: 11.23"
- Ride Height: 14.50"
- Extended: 16.43"





Major ComponentsIn the box

Item #	Part #	Description	QTY
1	982-10-805	5.2" Stroke HQ Series Shock	2
2	815-05-022	Shock Eyelet	2
3	803-00-199(kit)	Upper CoilSpring Retainer (803-00-199 kit)	2
4	59120200	Coilspring 12" 200lb	2
5	70010828	Delrin Spring Washer	4
6	803-00-199(kit)	Lower Spring Adjuster Nut (803-00-199 kit)	2
7	803-00-199(kit)	Adjuster Nut Locking Screw (803-00-199 kit)	2
8	803-00-199(kit)	Retaining Ring (803-00-199 kit)	2
9	90002043	1/2" ID Upper Bearing Spacers	4
	90001994	5/8" ID Bearing (installed in shock and eyelet)	4
	90001995	Bearing Snap Ring (installed in shock and eyelet)	8

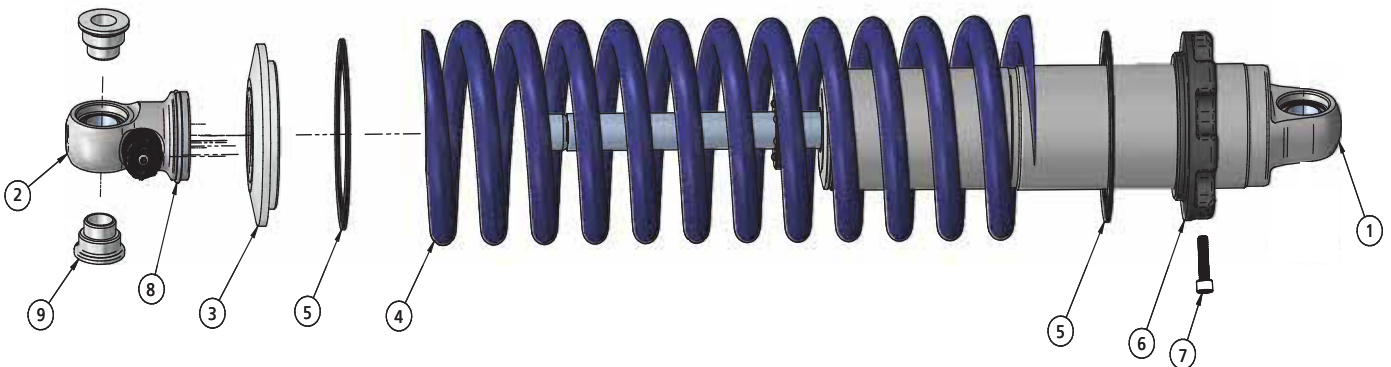

CoilOver Installation



1. Refer to the 4-link instructions for CoilOver installation. Mount the CoilOver with the shock body up for easier shock knob access. See **Image 1**.



CoilOver Assembly...



1

First, using the supplied lower adjuster nut (803-00-199) thread the nut onto the shock from the bottom side as seen in figure 1. Remove the plastic pellet that is in the split of the adjuster nut.



2

Next, install a delrin washer then coil spring over the top of the shock as seen in figure 2.



3

Before the upper spring mount can be installed screw the adjuster knob on the upper eye mount to the firmest setting (clockwise) as seen in figure 3. Then remove the Knob by holding it while removing the center screw.



4

Once the knob is removed slide a Delrin washer over the eyelet. Next, slide the upper spring mount (803-00-199) over eyelet as seen in figure 4.



5

Install upper spring mount retainer clip (803-00-199) into the groove on the upper eyelet as seen in figure 5. Then, reinstall adjuster to complete assembly.

Install the locking screw in the adjuster nut before setting spring preload, but DO NOT tighten until the spring preload has been set.

NOTE: Remember to adjust the shock valving before driving, the shock is currently set to full stiff.

CoilSpring Adjustment

Adjusting Spring Height

When assembling the CoilOver, screw the spring retainer tight up to the spring (0 preload). Measure from the bottom of the adjuster nut to the flat of the shock. Thread the adjuster up the shock 1" to preload the spring. Tighten the locking screw that is in the adjusting nut to lock the adjuster in place. After entire weight of truck is on the wheels, jounce the suspension and roll the truck forward and backward to alleviate suspension bind.

- If the truck is too high with 1" of preload, reduce the amount of preload that is on the spring by threading the adjusting nut down the shock body.
- If the truck is too low with 1" preload, then preload can then be added by threading the spring retainer up to achieve ride height.
- Lock the adjusting nut in place by tightening the locking screw that is the adjusting nut.



TUNING GUIDE

SINGLE-ADJUSTABLE SHOCKS



The Basics...

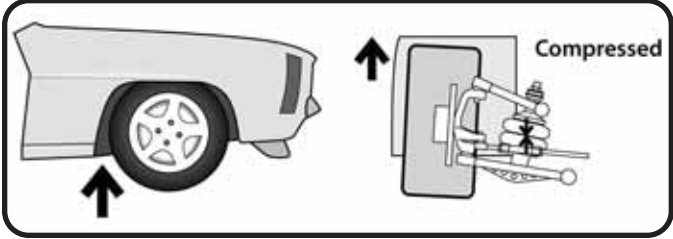

COMPRESSION

This typically occurs when you hit a bump in the road. The bump forces the wheel/tire/suspension assembly to "compress" or move upwards into the car.

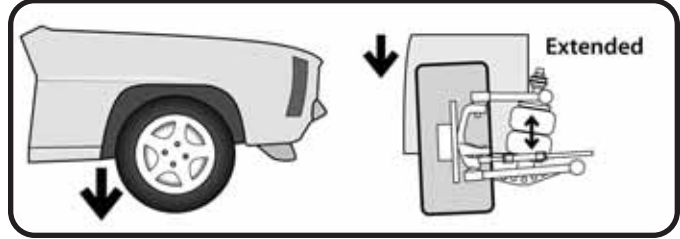

REBOUND

Rebound is the opposite of compression. This occurs when the wheel/tire/suspension assembly falls into a pothole, or simply "rebounds" from being compressed.

Where Are The Knobs?

HQ Series Shocks

- The adjustment knob is located on the top of the shock, either protruding from the side of the eyelet, or atop the stud.
- This knob provides rebound adjustment only.

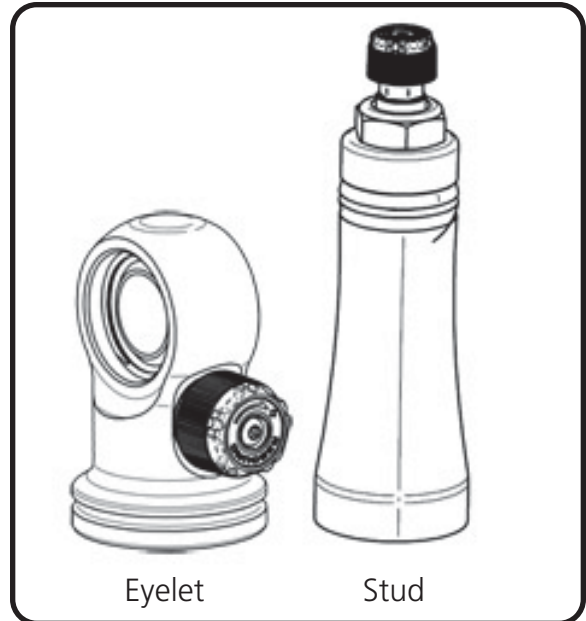

Knob Function

Counterclockwise

=
Softer



Clockwise

=
Firmer





TUNING GUIDE

SINGLE-ADJUSTABLE SHOCKS



Initial Rebound Setting

NOTE: Before jumping straight to a middle-of-the-road shock setting, we recommend you experience the full range of adjustment potential of your new shocks by first driving your vehicle at both the “full stiff” and “full soft” settings. Understanding how your shocks behave at these extremes will provide recognizable reference points as you attempt to dial in your settings.

1. Begin by setting your shocks to the “full stiff”, or minimal rebound position. You do this by turning the adjustment knob clockwise until it stops.

2. Now turn the adjustment knob counterclockwise 12 clicks. This is the approximate center of the adjustment range.

3. Take the vehicle for a test drive. Try to determine if you are experiencing any of the unwanted behaviors found at the extremes of the adjustment range. If you are satisfied with the ride quality and handling, you’re all set. Enjoy the ride!

4. If the vehicle feels too “floaty” or soft, turn the knob a few clicks clockwise to increase the damping effect.

If the ride quality is still too harsh or stiff, turn the knob a few more clicks counterclockwise to decrease the damping effect.

5. Take the vehicle for another test drive. If necessary, repeat the steps above until your desired optimal ride quality has been achieved.



General Guidelines

- The rear shocks typically have the most influence on ride quality. This is due to your seating position being closer to the rear than the front.
- Adjustments to the front shocks will generally require 3-4 clicks in any direction to be noticeable, while adjustments to the rear shocks may only require 1-2 clicks to be felt.
- Don’t be afraid to turn the knobs and experience the full adjustment range. You are not going to hurt anything and you can always go back if you adjust too far one way or the other.