



Part # 12095010 - 1964-1966 Mustang StreetGrip

Front Components

12099590	Delrin Control Arm Bushings
12092350	Front Dual Rate CoilSprings
12099515	Front HQ Series Shock Kit
12099120	Front Sway Bar

Rear Components

12094810	Composite Leaf Springs
12095399	Delrin Leaf Spring Bushings
12099510	Rear HQ Series Shock Kit

Recommended Tools

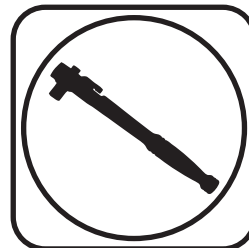

1964-1966 Mustang StreetGrip Installation Instructions

Table of contents

Page 2.....	Major Components and Hardware List
Page 3.....	Getting Started
Page 4-8.....	Delrin Bushings
Page 9.....	Front Dual Rate CoilSpring
Page 10-12.....	Front Sway Bar
Page 13-16.....	Front HQ Series Shock Kit
Page 16-19.....	Composite Leaf Springs & Delrin Bushings
Page 19-24.....	Rear HQ Series Shock Kit

The majority of the StreetGrip components will be installed together. For example, the Front CoilSprings, Control Arm Bushings and Shock Kit will be installed in conjunction with each other. On the rear, the Leaf Springs, Delrin Bushings and Shock Kit will be installed in conjunction with each other. The front Sway Bar will need to be installed **after** the rest of the front components are installed.

WILL NOT FIT CONVERTIBLES





Major ComponentsIn the box

Part #	Description	QTY
55490792	Front CoilSprings- Small Block	2
12094810	Rear Leaf Springs w/ Delrin Bushings & Inner Sleeves Installed	2
90003577/90003578	Leaf Spring Clamp Plate/Lower Shock Mount D & P	2
70013973	1" Lowering Block w/70012898 pressed in	2
90002655	Upper Cross Shaft	2
70012644	Delrin Bushing Outer Shell - Upper Control Arm -	8
70012646	Delrin Bushing - Upper Control Arm	8
90002630	Upper Bushing Inner Sleeve	4
70012625	Strut Rod Delrin Ball	4
70012626	Strut Rod Delrin Ball Cap	4
90002656	Strut Rod Delrin Ball Inner Sleeve	2
90002657	Strut Rod Bushing End Spacer	4
986-10-092	3.85" Stroke Stud Top Shock - Front	2
90002104	Lower Stud Plate - (Installed on Shock) - Front	2
90002654	Upper Shock Mount - Front	2
70011140	Stud Top Bushing - Front	4
70011141	Stud Top Bushing Washer - Front	4
986-10-085	5.25" Stroke Eyelet Top Shock - Rear	2
70011138	3/4" ID Shock Bushing (Installed in Shock) - Rear	4
90002103	5/8" ID Shock Sleeve (Installed in Shock Eyelet)	2
90002102	1/2" ID Shock Sleeve (Installed in Shock Eyelet)	2
90001617	Shock Stud	2
12099120	Front Sway Bar Kit	1
90002496	Leaf Spring Shackle Plates	4
70012605	Frame Shackle Bushing	4
90000519	Leaf Spring Bushing Inner Sleeve	2
90002616	Rear Upper Shock Mount - Driver	1
90002614	Rear Upper Shock Mount - Passenger	1
90002617	Upper Shock Mount Clamp Plate - Driver	1
90002615	Upper Shock Mount Clamp Plate - Passenger	1



Getting Started.....

Congratulations on your purchase of the Ridetech StreetGrip Kit. This system has been designed to give your car excellent ride and handling along with a lifetime of enjoyment. Some of the key features of this Kit: Dual Rate CoilSprings, Composite Leaf Springs, Delrin Control Arm & Leaf Spring Bushings, Larger Swaybar with Delrin Liners and a Ridetech HQ Series Monotube Shocks.

The majority of the StreetGrip Components will be installed together. For example, the Front CoilSprings, Control Arm Bushings and Shocks will be installed in conjunction with each other. On the rear, the Leaf Springs, Delrin Bushings and Shocks will be installed in conjunction with each other. The front Sway Bar will need to be installed after the rest of the front components are installed.

Hardware Kit#99010070

The StreetGrip Kit is supplied with a hardware kit. This hardware kit contains individual bags for the different kits within the main kit. The bags are labeled to help determine the correct hardware for the installation of the specific kits. The instructions will aid you in selecting the correct hardware for each component. The bags included in this kit are:

- Front Sway Bar Kit
- Control Arm Kit
- Ball Joint Kit
- Leaf Spring Kit
- Front Shock Kit
- Rear Shock Kit

Front Suspension

The front components that will need to be installed are: Control Arm Bushings, Shocks, and CoilSprings. The Sway Bar needs to be installed after the rest of the front components are installed.

If you have never done this type of work before, we recommend getting a Factory Service Manual for proper procedures of disassembly and reassembly of the components for your car.

Rear Suspension

The rear components that will be installed are rear Composite Leaf Springs, Delrin Leaf Spring Bushings, and rear HQ Series Shocks. The Composite Leaf Springs and Delrin Leaf Spring Bushings will be installed at the same time. The Delrin Leaf Spring Bushings are preinstalled in the Leaf Springs.

Alignment Specs

Anytime you change suspension components, you should have the car alignment checked.

Suggested Alignment Specs:

- Camber: Street: -.5 degrees
- Caster: Street: +3.0 to + 5.0 degrees
- Toe: Street: 1/16" to 1/8" toe in



Part # 12099590 - 1964-1966 Mustang Delrin Control Arm Bushings



Recommended Tools

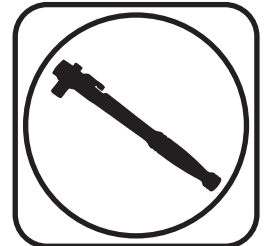

**1964-1966 Mustang Delrin Control Arm Bushings
Installation Instructions**

Table of contents

Page 2..... Included Components and Hardware List

Page 3-4..... Bushing Installation



Major ComponentsIn the box

Part #	Description	QTY
90002655	Upper Control Arm Cross Shaft	2
70012644	Upper Control Arm Bushing Outer Shell	4
90002630	Upper Bushing Inner Sleeve	4
70012646	Upper Delrin Control Arm Bushing	4
70012625	Strut Rod Bushing, Inner Delrin Ball	4
70012626	Strut Rod Bushing, Outer Cap	4
90002656	Strut Rod Bushing, Inner Sleeve	2
90002657	Strut Rod Bushing, End Spacer	4
70012675	Drilling Template	1
90002627	4 Bolt Ball Joint Wedge	2
90002628	3 bolt Ball Joint Wedge	2
90002629	Ball Joint Wedge Washers	8
99250003	1/4"-28 45 Degree Grease Zerk	2

Hardware Bags - Control Arm Kit & Ball Joint Kit

99562007	9/16"-18 Mechanical Lock Nut	Upper Control Arm Shaft Nuts	4
99563002	9/16" SAE Flat Washer	Upper Control Arm Shaft Washers	4
99501043	1/2"-13 x 2" Hex Bolt	Upper Cross Shaft Mounting	4
99503001	1/2" SAE Flat Washer	Upper Cross Shaft Mounting	4
99502015	1/2"-13 Mechanical Lock Nut	Upper Cross Shaft Mounting	4
99562002	9/16"-18 Jam Nut	Strut Rod Nut	2
99311028	5/16"-18 X 1 1/2" Hex Bolt	Ball Joint Wedge	8
99313002	5/16" SAE Flat Washer	Ball Joint Wedge	8
99312002	5/16"-18 Nylok Nut	Ball Joint Wedge	8
99501001	1/2"-13 x 1" Hex Bolt	Template	2
99502006	1/2"-13 Hex Nut	Template	2

Getting Started.....

The Front Control Arms will need to be removed from the car. If it has any shims, mark them, they will be reinstalled in the same location they were removed from. Detach the Strut Rod from the Control Arm. Retain the OEM hardware for reassembly. Refer to the Factory Service Manual for disassembly procedure.

This Mustang Bushing Kit contains: 2 Upper Cross Shafts, 4 Upper Control Arm Bushing Assemblies and 2 Strut Rod Bushing Assemblies. The Upper Bushings are all the same. The Kit does not include a Lower Control Arm Bushing.

The OEM Bushings are removed by threading them out of the Control Arm. It is easier to do with the cross shaft clamped in a vise.



Delrin Bushing Installation

The Cross Shaft must be put in place before installing the Bushing Shells in the Upper & Lower Control Arms.

There are several ways the Delrin Bushing Assemblies can be installed. No matter the method used, the Control Arm needs to be **SUPPORTED** to keep from distorting the Control Arm. We recommend cutting spacers to go inside the Control Arms when using a Press to install the Bushings. We have used several different methods to install the Bushing Assemblies. We are going to cover the one that worked best for us. When installing the Bushings, the Outer Shell will be installed in the Arm by itself. Next, Press in the Delrin Bushing, followed by the Inner Sleeve.

DUE TO VARIATIONS IN THE THREADS OF THE CONTROL ARM, WE RECOMMEND TACK WELDING THE BUSHING SHELLS TO THE CONTROL ARM.

Note: The Delrin is self-lubricating, no lubricant is needed.

1. Measure the **Outside Width** of the Control Arms and write it down before starting Bushing Removal. You will use this dimension to check the Control Arms after the new Delrin Bushings are installed.



2. **Disassemble the Bushing being installed. When installing Bushings in the control arms, insert the Cross Shaft before installing any Bushings. Support the back side of the flange the Bushing is being Installed in.** They can be supported by either the piece of Metal or by the Bench Vise with the Jaws opened wide enough to let the Bushing Shell pass through (**Figure 2**).

3. We used a socket to drive the Outer Shell into the control arm. Drive it in until the Shell stops against the control arm.

4. Press the Delrin Bushing & Inner Sleeve into the Bushing Shell. Again, we used a socket large enough to clear the threads of the cross shaft. Tap them in until the Bushing stops against the Shell and the Inner Sleeve stops against the cross shaft.

5. Install the 9/16" Washer & 9/16" Lock Nut and finish pushing the Bushings in with the hardware. Tighten Hardware to eliminate any gaps between the Bushings and cross shaft. (**Figure 3**) Shows the Control Arm Bushings assembled with the hardware installed.





Bushing Installation

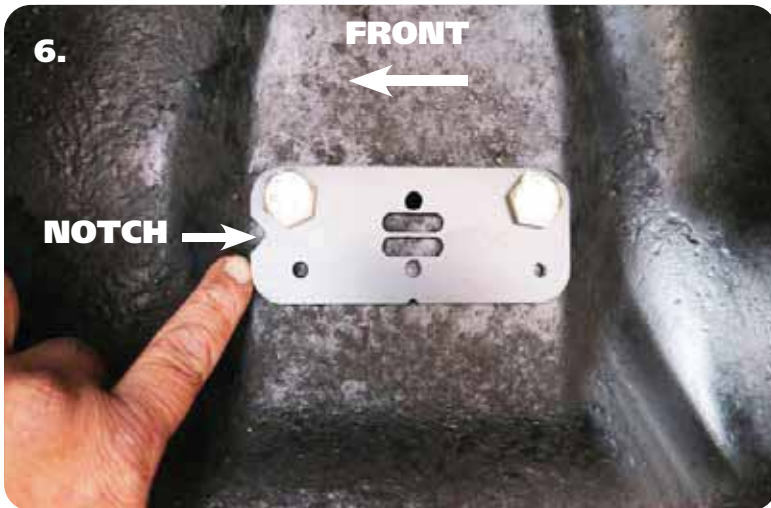

6. This Kit includes a Template for redrilling the upper control arm mounting holes. Use the 1/2"-13 x 1" Bolts to help locate the Template. Insert the 1/2" Bolts into the 2 holes in the Template. Next, install the Template in the control arm location with the **NOTCH FORWARD** and the 1/2" Bolts to the top. Use the 2 small holes to mark the holes that need drilled. Center punch the marks and remove the template. Drill the center punched marks to 1/2". Reinstall the upper control arms in the new holes. Reinstall any shims that were removed during disassembly. Install a 1/2" Flat Washer and 1/2" Mechanical Locking Nut on the engine side of the control arm mount.

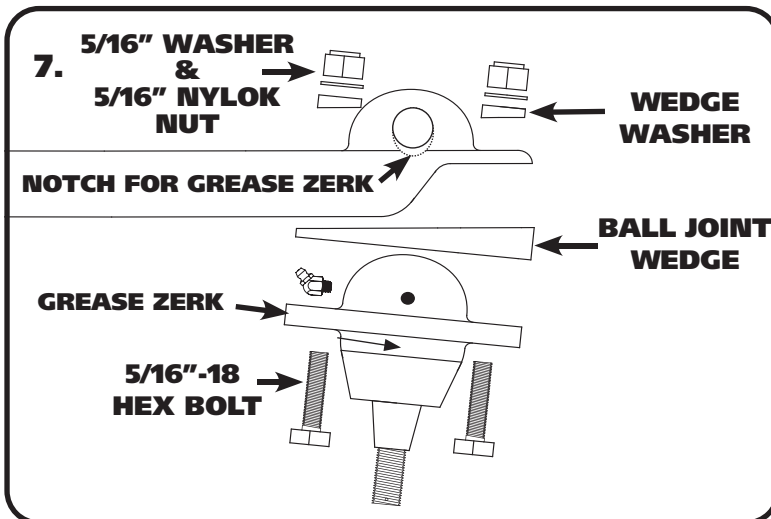

7. The Kit contains Ball Joint Wedges to correct the ball joint angles due to the upper control arm pivot point being lowered. Your control arms will either have 3 or 4 bolts attaching the ball joint to the control arm, this kit contains wedges for both. First, remove the upper ball joint by either unbolting or removing the rivets. The rivets can be removed by either cutting the heads off and driving out or by drilling them out. Use **(Figure 7)** as a reference to install the wedges. The wedge gets installed between the upper control arm and the ball joint with the THICK SIDE OUT. The wedge shaped washers go on the top side of the arm. Install a Wedged Washer on each of the 5/16"-18 x 1 1/2" bolts required to attach the Wedge/Ball Joint. Insert the Bolts into the holes in the control arm. Slide the Wedge on the Bolts with the THICK SIDE OUT. If your ball joint has the grease zerk sticking out of the side, the control arm will need to be notched to clear the 45 Degree Grease Zerk that is included in the kit. Next, install the ball joint followed by a 5/16" Flat Washer and 5/16"-18 Nylok Nut on each bolt. Tighten Hardware.



8. A Delrin Bushing setup for the strut rod is also included in this kit. The liner that is installed in the frame hole has to be removed. Use a chisel to distort it and remove it. In **(Figure 10)** we distorted it from the bottom edge and removed it.



Strut Rod Delrin Bushing Installation



9. Refer to **(Figure 10)** for the Delrin Strut Rod Bushing assembly order. The Delrin Strut Rod Bushing will insert into the frame bushing hole with the rounded side of the bushing outward. A Bushing needs to be installed on both the front and rear side of the frame. With a Delrin Strut Rod Bushing on each side of the frame, insert the INNER Sleeve in the Bushings. This will help hold them in place.

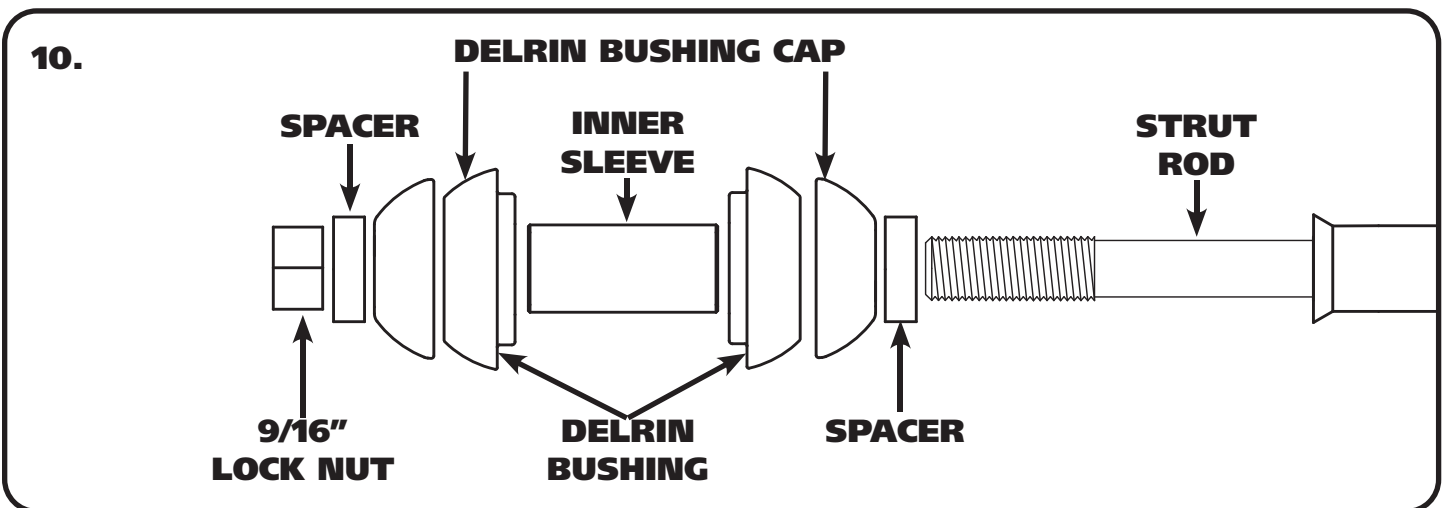

10. Install a Spacer on the strut rod followed by the Delrin Bushing Cap. Insert the strut rod through the Bushing Sleeve until the Ball is nested into the Bushing Cap. Install a second Bushing Cap on the strut rod followed by a 2nd Spacer. Next, install a 9/16" Lock Nut on the threads of the strut rod. Install the OEM castle nut on the end of the strut rod with a cotter pin through it.

NOTE: The Spacers that are on each side of the Delrin Ball Caps can be used to help get the alignment set. Meaning they can both be on the front side of the Delrin Ball Assembly or on the back side of the Assembly. This can help with Caster Adjustment.

11. Reinstall the lower control arm using the OEM eccentric bolt. Reattach the strut rod to the lower control arm using the OEM hardware.

12. Reinstall the spindles using the OEM Hardware.



Part # 12092350 1964-1966 Mustang Front CoilSpring



Recommended Tools

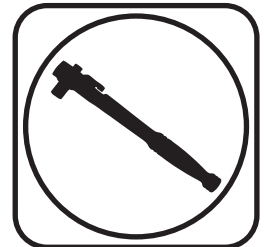

1964-1966 Mustang Front CoilSprings Installation Instructions

CoilSpring # 55490792 Installation

Front dual-rate spring will allow the vehicle to transition small road irregularities via a soft spring rate. When the vehicle compresses the spring far enough (through large bumps or cornering), it transitions to the firmer spring rate to control the bump or body roll. We have worked closely with Hyperco to develop custom dual rates to ensure the best ride possible.

The Front Control Arm Bushings and Strut Rod Bushings should be installed before installing spring. The Front Suspension should be assembled without the Shock installed.

1. CLOSE COILS TO THE BOTTOM.

2. With the OEM Spring Removed, insert the CoilSpring into the Pocket. SPECIAL ATTENTION NEEDS TO BE PLACED ON THE LOCATION OF THE ENDS OF THE SPRINGS TO MAKE SURE THEY ARE CLOKED CORRECTLY . The end of the CoilSpring will nest into the receiver area of the Spring Mount. If you line up the bottom, the top will be correct.

3. Pull down on the Control Arms and install the CoilSpring. Install the Shock to help hold the springs in place.





Part # 12099120 - 1964-1966 Mustang Front SwayBar

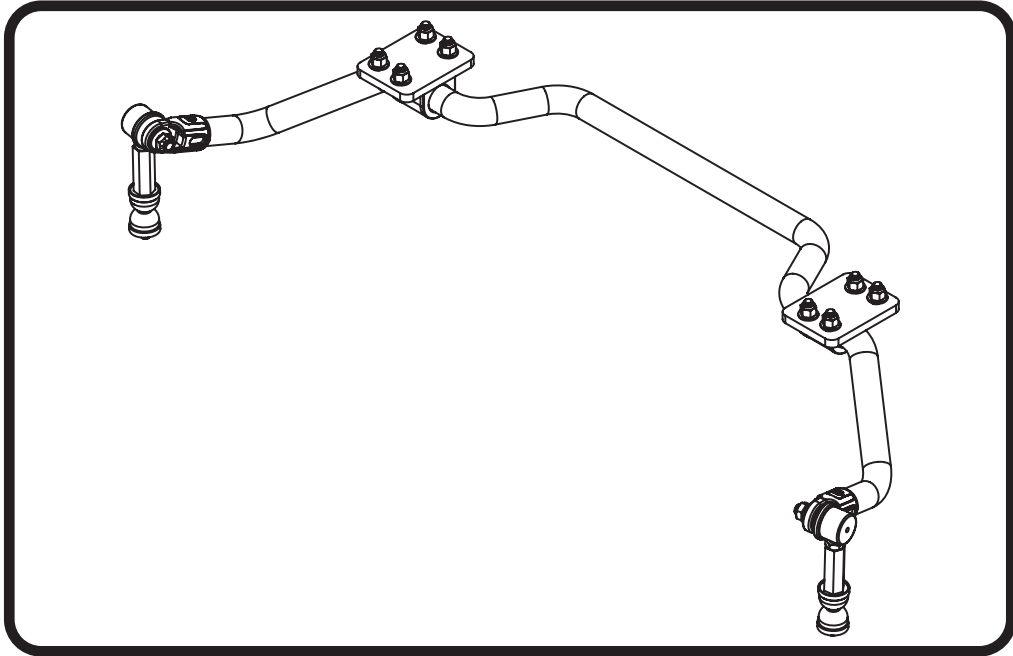

Recommended Tools



1964-1966 Mustang Front SwayBar Installation Instructions

Table of contents
Page 11..... Included Components and Hardware List
Page 11-12..... SwayBar Installation

Hardware Torque Specifications

M10-1.5.....	37 ftlbs
3/8"-16.....	35 ftlbs

Major ComponentsIn the box

Part #	Description	QTY
90003248	SwayBar	1
90003213	Offset Bushing Mount	2
70015013	Lined Sway Bar Bushing	2
90002572	Sway Bar Bushing Strap	2
90001258	SwayBar End Link T-Bushing - 10mm I.D.	4
90003249	Stock Control Arm T-Bushng - 5/8" I.D.	2
END LINK ASSEMBLY		
90001256	90 Degree End Link Adapter	2
90002571	90 Degree End Link	2
99375008	3/8"-16 x 3" Threaded Stud	2
90002930	End Link Kit	2

HARDWARE BAG - Front Sway Bar

Part #	Description	Usage	QTY
99371005	3/8"-16 x 1 1/4" Hex Bolt	Frame Mount to Frame	4
99373002	3/8" Flat Washer	Bushing Strap & Frame Mount	12
99372001	3/8"-16 Nylok Nut	Bushing Strap & Frame Mount	8
99623001	5/8" SAE Flat Washer	End Link to Control Arm	2
99371032	3/8"-16 x 1 1/4" Socket Head	Bushing Strap	4
99373020	3/8" x 5/8" OD Flat Washer	Bushing Strap	4

Getting Started.....

Note: This sway bar kit utilizes a anti-friction lining in the sway bar bushing. The lining allows the sway bar to move freely and quietly in the bushing. No lubrication is required.

1. Jack the vehicle up to a safe working height and support with jack stands. Make sure the jack stands are stable before working under the car.
2. Remove the stock sway bar.



3. Open the sway bar bushing at the split and slip it **OVER** the sway bar. Do this for both bushings.



4. Slip the bushing straps over the swaybar bushings.



5. The offset mounting plate will get bolted to the OEM sway bar mount. It is bolted to the OEM holes using the SLOTTED holes in the offset plate with the (2) round holes offset toward the engine. Install a 3/8" flat washer on (2) 3/8"-16 x 1 1/4" hex bolts. A bolt/washer will go in each of the (2) mounting holes. Insert a bolt/washer through each slotted hole and OEM mounting hole. With the bolt/washers installed, install a 3/8" flat washer on the threads followed by a 3/8"-16 nylok nut.



6. Install the sway bar in position in the car. The center of the bar should be to the front of the car. The outer arms of the sway bar will bend upward. Install a 3/8" x 5/8" OD flat washer on (4) 3/8"-16 x 1 1/4" socket head bolts. A bolt/washer will go in each of the 4 mounting holes. With the bolt/washers installed, install a 3/8" flat washer on the threads followed by a 3/8"-16 nylok nut. Do **NOT** completely tighten the hardware. It will be left partially loose until the end links are installed.

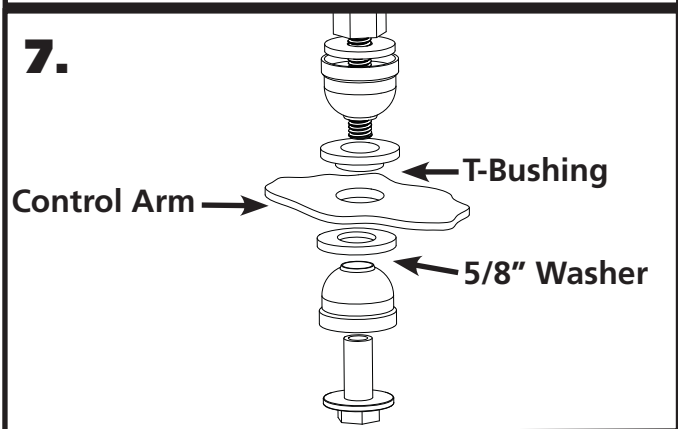

7. Install the End Links using **Diagram 8** as a reference. Insert the SMALL diameter of the 5/8" ID t-bushing into the stock sway bar hole of the lower control arm. A 5/8" washer goes on the bottom side of the control arm. Tighten the end link barrel nut until it is flush with the end of the bolt, and then tighten it 2 more complete rounds.



8. Install a T-Bushing on each of the 90 degree end links. The t-bushings are installed with the large diameter against the shoulder of the end link.



9. Insert the 90 degree end link/t-bushing into the swaybar end with the threads pointing toward the WHEEL. Install a 2nd t-bushing with the small diameter into the swaybar. Install the nut and torque. Do this for both sides.

10. Torque the swaybar mounting hardware.



Part # 12099515 - 1964-1966 Mustang Front Shock Kit



Recommended Tools

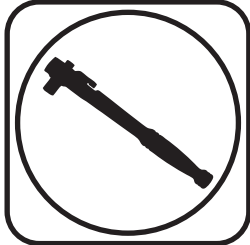

HQ Series Front Shock Kit Installation Instructions

Table of contents
Page 14..... Components & Getting Started
Page 15..... Shock Installation
Page 16..... Stud Bushings

THE RIDETECH DELRIN BUSHINGS (12109590), COILSPRINGS (12092350) & SWAY BAR (12099120) ARE RECOMMENDED TO ACHIEVE MAXIMUM PERFORMANCE.



3.85" HQ Series Smooth Body Shocks

Major ComponentsIn the box

Part #	Description	QTY
986-10-092	3.85" Stroke Shock	2
90002104	Stud Plate (Installed on Shock)	2
99371039	3/8"-24 x 5/8" FHCS (Installed on Shock)	2
99311020	5/16"-24 x 1 1/4" BHCS (Installed on Shock)	2
72000229	Stud Plate Bushings	2
70011140	Stud Top Bushings	4
70011141	Stud Top Bushing Washers	4
90002654	Upper Shock Mounting Plate	2

Hardware Bag - Front Shock Kit

Part #	Description	Usage	QTY
99372006	3/8"-24 Jam Nut	Upper Shock Bushings	4
99312001	5/16"-24 Nylok Nut	Lower Shock Mount	4
99313002	5/16" Flat Washer	Lower Shock Mount & Upper Plate	10
99311027	5/16"-18 x 3/4" Carriage Bolt	Upper Shock Mount Plate	6
99312003	5/16"-18 Nylok Nut	Upper Shock Mount Plate	6

Getting Started.....

FOR OPTIMUM PERFORMANCE, THIS KIT SHOULD BE USED IN CONJUNCTION WITH THE STREET-GRIP COIL SPRINGS, DELRIN BUSHINGS, AND SWAY BAR.

1. Remove the OEM shock setup along with the OEM upper shock mount. If the car is equipped with a shock tower brace, it will need to be moved out of the way to install the new Upper Mount. It can be reinstalled while installing the new Upper Mount.

REPLACE THE CONTROL ARM BUSHINGS AND COIL SPRINGS BEFORE INSTALLING THE NEW SHOCK KIT.



Shock Installation

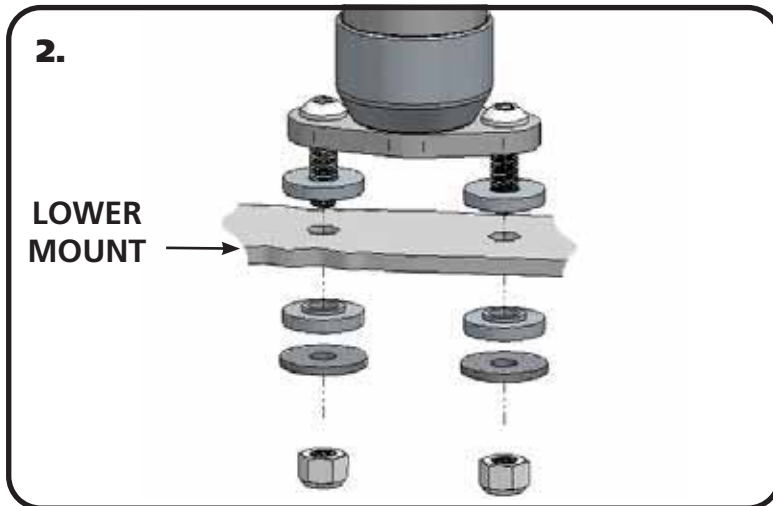

2. **(Figure 2)** shows the assembly of the lower shock bushings. Install a Bushing on the each of threads protruding through the lower shock plates.



3. Using **(Figure 5)**, install a Stud Top Bushing Washer and Bushing on the Stud Top of the Shock. Insert the Shock through the OEM opening. Insert the studs into the openings in the lower mount. Using **(Figure 2)** as a reference, install a Bushing, Washer and Nut on each stud and tighten.



4. Insert the supplied 3/8"-16 x 1" Carriage Bolts in the OEM keyhole slots in the top of the shock tower. Install the Upper Shock Plate on the Carriage Bolts with the Stud Top of the Shock inserted into the center hole. The Inner Hole on the Shock Plate is offset if the holes are not lining up, FLIP IT OVER. If the car has a strut tower brace, install in on top of the plate. Once everything is in place, install a 3/8" Flat Washer & 3/8"-16 Nylok Nut on the threads sticking up. Tighten the hardware.



Shock Installation

5.

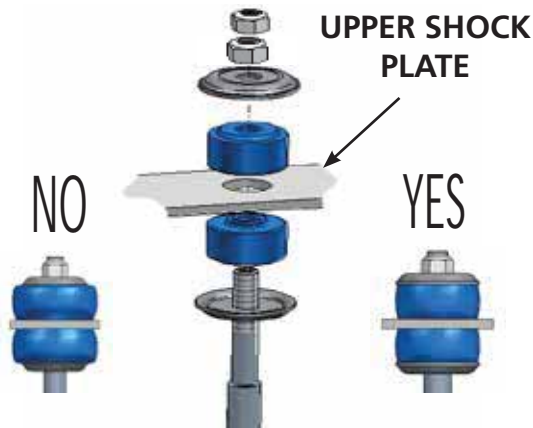

5. Remove the adjuster knob by loosening the set screw using the supplied Hex Key. Install a Bushing Support Washer on to the shock shaft followed by a Shock Stem Bushing. Insert the assembly through the installed plate. Install a Shock Stem Bushing on to the shock stud followed with a Bushing Support Washer. Install a 3/8"-24 Thin Jam nut onto the threads and tighten to 35 inlbs. The Bushing should be tight, but not to the point that the bushing is bulging past the Support Washer. Install the 2nd 3/8-24 Thin Jam nut and tighten it against the first nut. Reinstall the Adjuster Knob, align the set screw with the FLAT side of the adjuster shaft that is sticking out of the top of the shock shaft.

Part # 12094810 - 1964-1966 Mustang Composite Leaf Springs



Recommended Tools

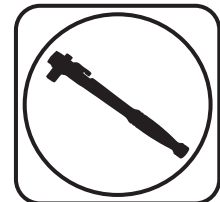

64-66 Mustang Composite Leaf Springs & Delrin Bushings Installation Instructions

Table of contents

Page 17..... Included Components and Hardware List

Page 18..... Delrin Frame Bushing Installation

Page 19..... Leaf Spring Installation

IT IS VERY IMPORTANT THAT NOTHING COMES IN CONTACT WITH THE COMPOSITE LEAF SPRINGS.



Major ComponentsIn the box

Part #	Description	QTY
90002909	Leaf Spring Blade Assembly w/70012652, 70012653, & 90000519 installed	2
70012605	Delrin Rear Shackle Frame Bushing - 1/4" Flange	4
90000519	Inner Bushing Sleeve	2
70013973	1" Lowering Block w/70012898 pressed in	2
90002496	Shackle Plate	4
90002758	3/16" Spacers	4

Hardware Bags - Leaf Spring Kit

Part #	Description	QTY
99501029	1/2"-13 x 6 1/2" Hex Bolt GR8 - FRONT	2
99501037	1/2"-13 x 4" Hex Bolt GR8 - REAR	4
99502007	1/2"-13 Thin Nylok Nut	6
99436001	7/16"-20 x 6 3/4" U-bolt	4
99432009/99433002	7/16"-20 High Nuts/ 7/16" Flat Washers	8



SWEDGED AXLE TUBES! - IF YOUR CAR EQUIPPED WITH A DIFFERENTIAL THAT HAS THE ENDS OF THE AXLE TUBES SWEDGED TO 2 1/4", YOU WILL NEED DIFFERENT U-BOLTS. YOU WILL NEED (4) OF RIDETECH PART # 99436004.

Getting Started.....

IT IS VERY IMPORTANT THAT NOTHING COMES IN CONTACT WITH THE LEAF SPRING.

1. Jack the car up and support it by the frame rails. You will need to raise and lower the rear differential with a jack to ease installation. With the car supported by the frame, put the jack underneath the rear end housing and raise the jack up just enough to support the differential. Remove the rear leaf springs & OEM shocks.
2. The Delrin Bushings will be preinstalled in the Composite Leaf Springs. The Delrin Frame Bushings will need to be installed. Start by removing the OEM frame bushings.
3. The Shackle Plates and Hardware can be used to push the rear bushings and sleeves into the frame location. Start by inserting an Inner Sleeve into a Bushing from the inner side (opposite of the flange). Push the sleeve in until it is flush with the flange side of the bushing. Insert the bushing/sleeve into the shackle bushing hole. Insert a 2nd bushing half in the opposite side pushing it onto the sleeve as far as you can by hand. Insert a 1/2"-13 bolt into a shackle plate. Insert the bolt/shackle plate into the bushing/sleeve and install a second shackle plate on the threads sticking out of the bushing. Install a 1/2"-13 nut and tighten until the bushings bottom out on the frame.

THESE LEAF SPRINGS ARE DESIGNED AND MADE FROM BLANKS. THE BLANK FOR YOUR SPRING COULD HAVE THE WORD "CHEVROLET" ON IT. THIS ONLY MEANS THE FIRST VEHICLE THE BLANK WAS TESTED ON WAS A CHEVROLET. EACH VEHICLE HAS A SPECIFIC LENGTH, PIN LOCATION, AND SPRING RATE. THESE LEAF SPRINGS WERE DESIGNED SPECIFICALLY FOR THE MUSTANG.



Leaf Spring Installation

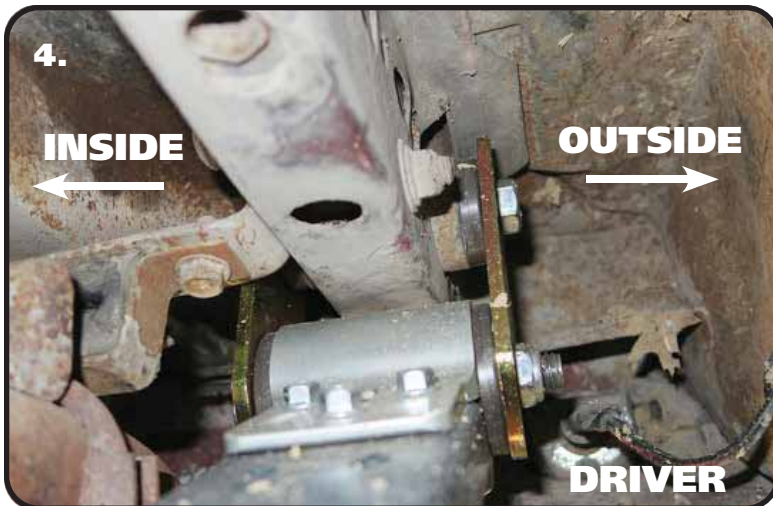

4 & 5. Attach the rear of the Composite Leaf Spring to the rear mount. THE REAR BUSHING IS THE **SMALLER** OF THE 2 LEAF SPRING BUSHINGS. New Shackles and Hardware is supplied with Delrin Bushings. The orientation of the hardware differs on the driver and passenger shackles. **Image 4** illustrates the driver side hardware orientation, **Image 5** illustrates the passenger side. Attach a Shackle Plate to each side of the Frame Bushing using a 1/2"-13 x 4" Bolt and 1/2"-13 Nylok Nut. Driver side bolt will need the threads pointing to the inside of the car. Passenger side will need the threads pointing to the outside of the car. Do not tighten. Align the remaining bolt holes in the shackle plates with the sleeve in the rear Leaf Spring bushing. Install a 1/2"-13 x 4" Bolt and 1/2"-13 Nylok Nut. Both sides will need the threads of the bolt pointing out. Do Not tighten hardware, it will get tightened later.

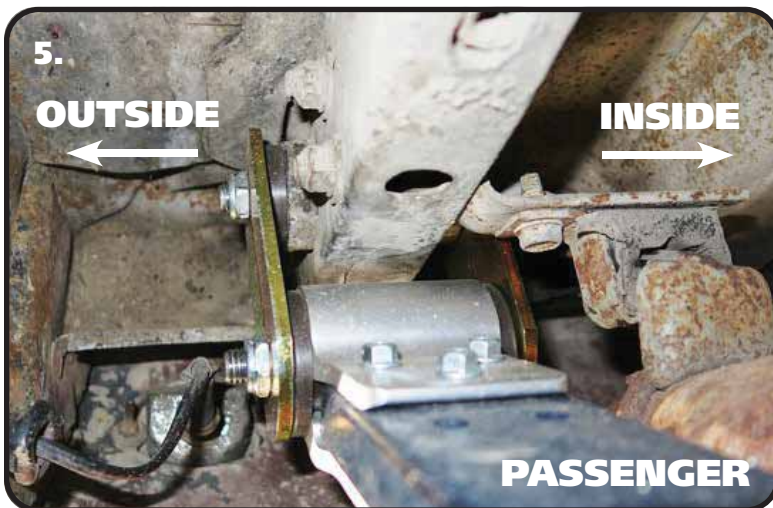

6. Swing the Leaf Spring up and attach the **LARGE BUSHING END** of the Composite Leaf Spring into the OEM front leaf spring mount using a 1/2"-13 x 6.5" Hex Bolt and 1/2"-13 Nylok Nut.

Note: You may have to jack the rear differential up enough to swing the leaf spring in place.





Leaf Spring Installation

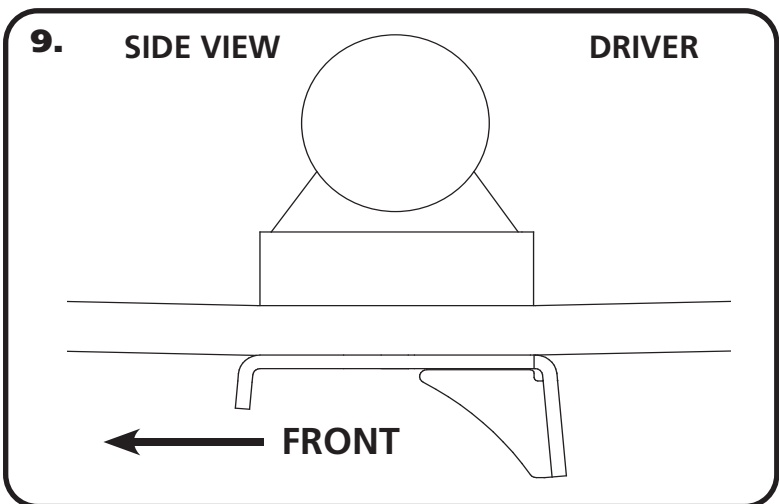
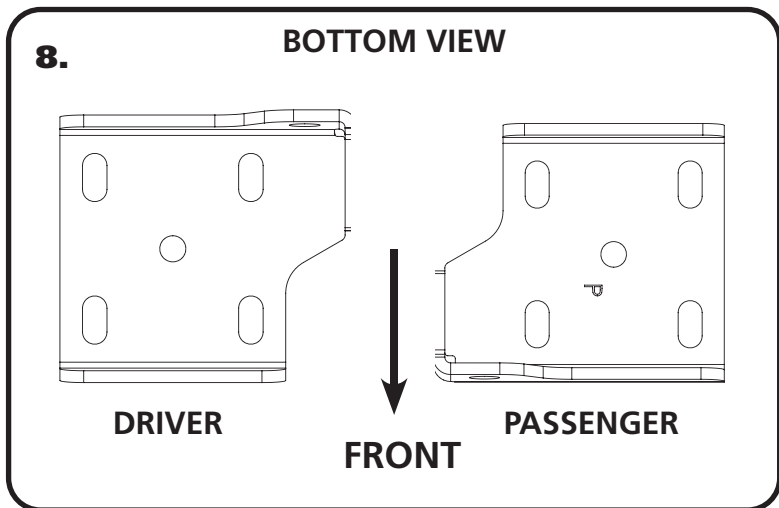
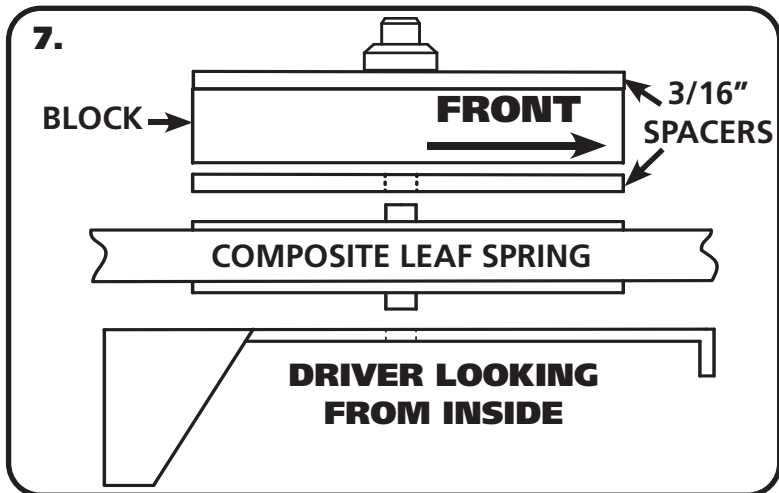

7. The Composite Leaf Spring has to be clamped in place with the Lower U-bolt Plate. If installing the Ridetech HQ Shock Kit too, new Plates are included with it. Install (1) 3/16" Spacer Plate on the Leaf Spring with the locating pin inserted in the center hole of the spacer. Next, install the 1" Lowering Block/Spacer Plate on top of the Spacer with the locating pin inserted into the center hole of the block. The 3/16" Spacers are to help even out the Clamping on the axle mount and leaf spring.

NOTE: Check the fitment of the Pin in the lowering block with the hole in the leaf spring pad. We have seen slight variations in the hole diameter due to the production process, it may be necessary to buff out the hole to get the pin to fit. **THE KIT INCLUDES A SMALLER PIN FOR CARS WITH THE SMALL LOCATING HOLE. YOU WILL NEED TO SWITCH THEM IN THE ALUMINUM BLOCK.**

8. Install the lower U-Bolt Plate/Shock Mount **being sure the Pins and Holes are aligned.** (Image 7) shows the U-bolt Plates/Shock Mounts as viewed from the bottom. (Image 8) shows the Driver Mount viewed from the outside of the car. The Driver Mount positions the bottom of the shock to the inside behind the axle. The Passenger Mount positions the bottom of the shock to the inside in front of the axle, IT HAS A "P" STAMPED IN IT. Install the 7/16" U-bolts on the axle tube in place of the OEM u-bolts. Slide the New U-bolt Plates onto the U-bolts using (Image 9) as a reference. Verify that the lower locating pin is indexed into the locating hole of the Plate. Install the hardware on each U-bolt. Evenly tighten the hardware by tightening in a crisscross fashion. Torque the nuts to 55 ftlbs. (Image 10) shows the Driver Plate installed.

Composite Leaf Spring Note: When tightening the mounts, pay attention to the pads on the springs to make sure there is visible compression of the pads. .030"- .060" of compression is needed for the springs to be securely mounted. All of the clamping force needs to be on the spring itself.



Leaf Spring Installation



10. Tighten the Bushing hardware, torquing it to 75 ftlbs. The Delrin Bushings will not bind, so it isn't necessary to have the car at ride height.

11. DOUBLE CHECK TO MAKE SURE NOTHING IS COMING INTO CONTACT WITH THE LEAF SPRING.

Part # 12099510 - 64-66 Mustang Staggered Shock Kit



Recommended Tools

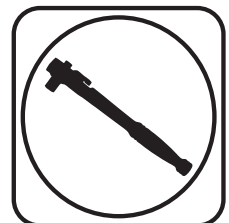

HQ Series Staggered Shock Kit Installation Instructions

Table of contents

- Page 21..... Components
- Page 22..... Getting Started and Lower Mount Installation
- Page 23..... Upper Mount Installation
- Page 24..... Shock Installation
- Page 26..... Shock Adjustment



5.25" HQ Series Smooth Body Shocks

Major ComponentsIn the box

Part #	Description	QTY
986-10-085	5.25" Stroke Shock	2
70011138	3/4" ID Shock Bushing (Installed in Shock)	4
90002103	5/8" ID Shock Sleeve (Installed in Shock Eyelet)	2
90002102	1/2" ID Shock Sleeve (Installed in Shock Body)	2
90002616	Upper Shock Mount Assembly - Driver	1
90002614	Upper Shock Mount Assembly - Passenger	1
90002617	Upper Shock Mount Inner Brace - Driver	1
90002615	Upper Shock Mount Inner Brace - Passenger	1
90001617	Lower Shock Stud	2
90000471	Cantilever Pin Spacer	2
90003577	Leaf Spring U-bolt Plate - Driver	1
90003578	Leaf Spring U-bolt Plate - Passenger "P" Stamped on Part	1

Hardware Bags - Rear Shock Kit

Part #	Description	Usage	QTY
99433002	7/16" Flat Washer	Passenger Upper Shock Mount to Body	1
99432001	7/16"-14 Nylok Nut	Passenger Upper Shock Mount to Body	1
99311011	5/16"-18 x 1 1/4" Hex Bolt	Driver Upper Shock Mount to Body	7
99312002	5/16"-18 Nylok Nut	Driver Upper Shock Mount to Body	7
99313002	5/16" Flat Washer	Driver Upper Shock Mount to Body	14
99501010	1/2"-20 x 2 1/4" Hex Bolt	Shock to Upper Shock Mount	2
99503001	1/2" Flat Washer	Shock to Upper Shock Mount	2
99502002	1/2"-20 Nylok Nut	Shock to Upper Shock Mount	2

The Rear Shocks will be installed in conjunction with the Rear Leaf Springs.



Upper Mount Installation

THE LOWER PLATES ARE INSTALLED ALONG WITH THE COMPOSITE LEAF SPRINGS.

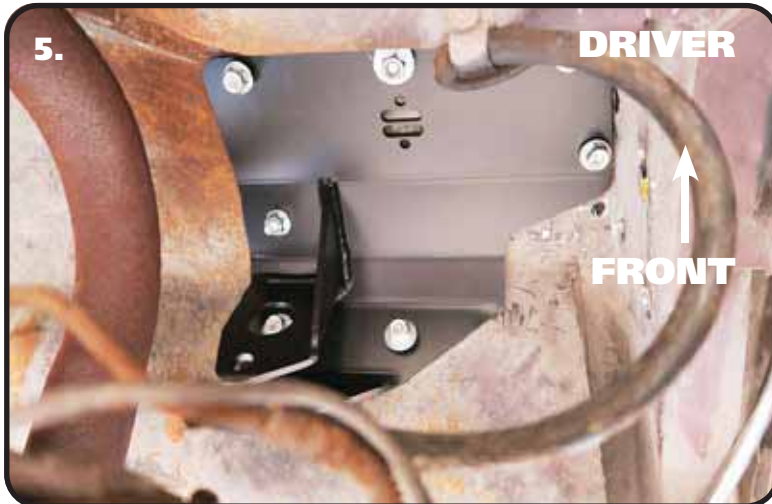

5. The Driver Upper Shock Mount repositions the top of the shock to behind the axle. The Mount nests in the car one way. Position the Mount in the car with the Shock attaching point to the rear and away from the frame. The outside edge of the mount will touch the frame with the front edge against a body seam. Using these points as a guide, the Mount will fit the contours of the body. With the Mount in position, use it to mark the 7 holes and drill them 5/16"



6. After drilling the 5/16" holes for the Driver Mount, position the backer plate on the inside of the car. Use **(Figure 6)** as a reference. When the Backer Plate is put into place, it will fit the contours of the body, aligning with the drilled holes. Install a Flat Washer on each of the 5/16"-18 x 1 1/4" Hex Bolts and insert them through the Backer and Body. Hold the Shock Mount in place and install a 5/16" Flat Washer and 5/16"-18 Nylok on each of the Bolts sticking through the Backer and Body. Tighten the hardware. A plug is supplied in the kit to seal off the driver side OEM shock hole.



7. Install the Passenger Shock Mount will be installed in the OEM location. The Shock Mount is shaped to fit the body and will only fit into the OEM location one way. Install the mount into the OEM location with the Stud sticking through the OEM shock hole. Have someone hold the mount in place while installing the top support and mounting hardware,



Shock Installation



8. Insert the Upper Backer through the shock access hole. Install it with the Stud from the Shock Mount sticking through the hole in the Backer. Rotate the Backer on the Stud to get it sitting flat against the body of the car. Once the Backer is positioned properly, install a 7/16" Flat Washer and 7/16"-14 Nylok Nut on the Stud and tighten. Make sure the Shock Mount stays positioned correctly while tightening.



9. The Shock is mounted in the Upper Mount with the BODY UP. It is held in place with a 1/2"-20 x 2 1/4" Hex Bolt & 1/2"-20 Nylok. If the threads of the bolt would happen to touch the floor pan of the car, a 1/2" Flat Washer can be installed under the head of the bolt.



10. The Lower Shock is Bolted to the Lower Shock Mount using the supplied Shock Stud. Install the Studs into the Lower Mounts with a Washer on each side of the Mount. Slide a Washer onto the Stud. Jack the Rear Differential up until the Shocks can be slid onto the Shock Stud. Slide the Shock onto the Stud with the Adjuster Knob pointing inward. Install the supplied 7/16" Flat Washer and Nylok Nut onto the Threads and tighten.

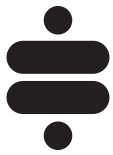

TUNING GUIDE

SINGLE-ADJUSTABLE SHOCKS



The Basics...

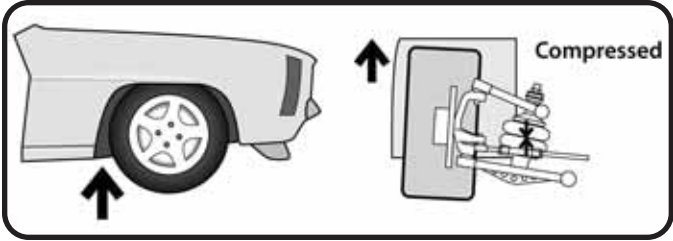

COMPRESSION

This typically occurs when you hit a bump in the road. The bump forces the wheel/tire/suspension assembly to "compress" or move upwards into the car.

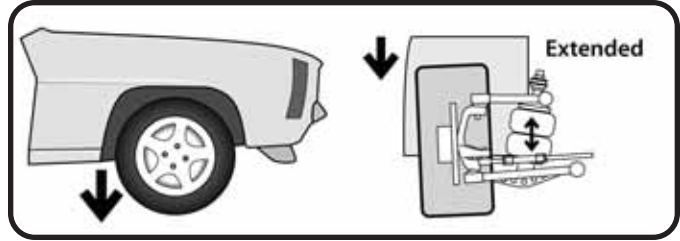

REBOUND

Rebound is the opposite of compression. This occurs when the wheel/tire/suspension assembly falls into a pothole, or simply "rebounds" from being compressed.

Where Are The Knobs?

HQ Series Shocks

- The adjustment knob is located on the top of the shock, either protruding from the side of the eyelet, or atop the stud.
- This knob provides rebound adjustment only.

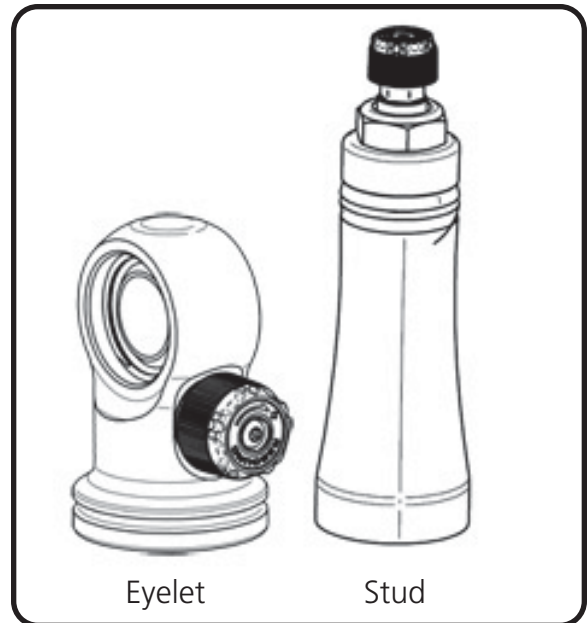

Knob Function

Counterclockwise

=
Softer



Clockwise

=
Firmer





TUNING GUIDE

SINGLE-ADJUSTABLE SHOCKS



Initial Rebound Setting

NOTE: Before jumping straight to a middle-of-the-road shock setting, we recommend you experience the full range of adjustment potential of your new shocks by first driving your vehicle at both the “full stiff” and “full soft” settings. Understanding how your shocks behave at these extremes will provide recognizable reference points as you attempt to dial in your settings.

1. Begin by setting your shocks to the “full stiff”, or minimal rebound position. You do this by turning the adjustment knob clockwise until it stops.

2. Now turn the adjustment knob counterclockwise 12 clicks. This is the approximate center of the adjustment range.

3. Take the vehicle for a test drive. Try to determine if you are experiencing any of the unwanted behaviors found at the extremes of the adjustment range. If you are satisfied with the ride quality and handling, you’re all set. Enjoy the ride!

4. If the vehicle feels too “floaty” or soft, turn the knob a few clicks clockwise to increase the damping effect.

If the ride quality is still too harsh or stiff, turn the knob a few more clicks counterclockwise to decrease the damping effect.

5. Take the vehicle for another test drive. If necessary, repeat the steps above until your desired optimal ride quality has been achieved.



General Guidelines

- The rear shocks typically have the most influence on ride quality. This is due to your seating position being closer to the rear than the front.
- Adjustments to the front shocks will generally require 3-4 clicks in any direction to be noticeable, while adjustments to the rear shocks may only require 1-2 clicks to be felt.
- Don’t be afraid to turn the knobs and experience the full adjustment range. You are not going to hurt anything and you can always go back if you adjust too far one way or the other.