

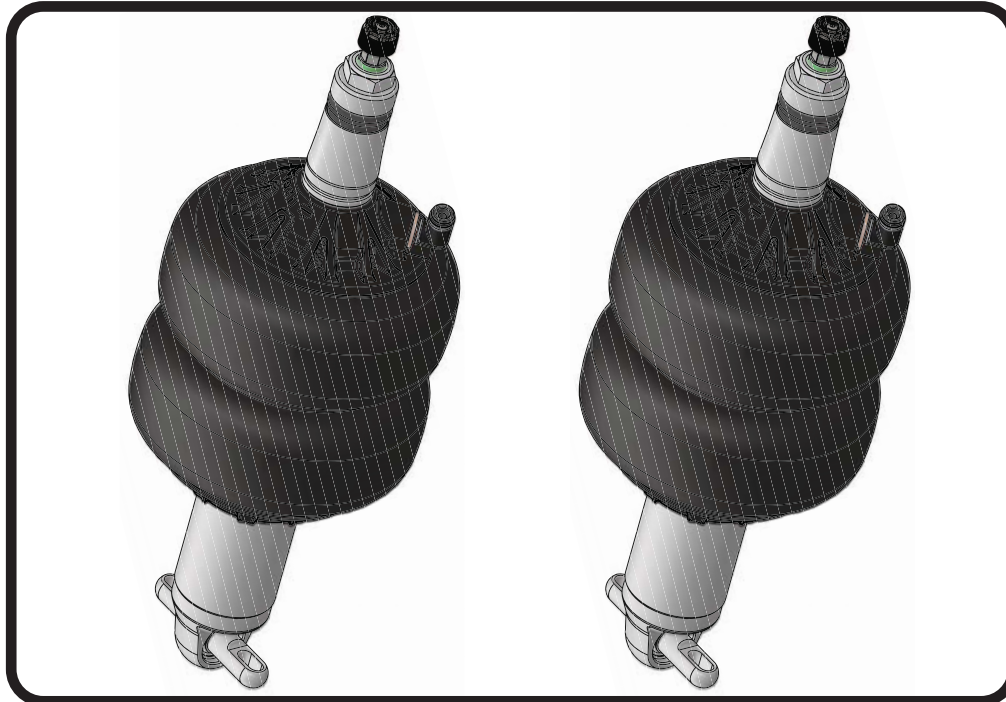

Part # 12102401

67-70 Mustang/Cougar Front HQ Shockwave, OEM Control Arms



Recommended Tools

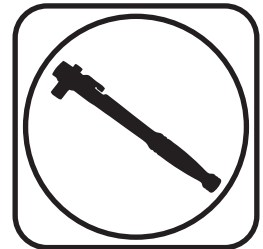

1000 Series Bellow, 2.0" Stud/Eye 2.9" Shock Installation Instructions

THESE SHOCKWAVES ARE DESIGNED TO BE USED WITH RIDETECH STRONGARMS

Table of contents

Page 2..... Included components

Page 3-4..... Shockwave Installation

Page 5-6..... Notes and Care of Your Shockwave & Shock Adjustment

ShockWave Dimensions:

Mount to Mount:

Compressed: 9.60"

Ride Height: 11.00"

Extended: 11.90"

www.ridetech.com
812-482-2932





Major ComponentsIn the box

Item #	Part #	Description	QTY
1	982-10-802	2.9" Stroke HQ Series Shock	2
2	90009988	2" Stud Top (Installed on Shock) - Includes Adjuster Knob & Screw	2
3	24090199	1000 Series 6.5" Double Convoluted AirSpring	2
4	234-00-153	AirSpring Locking Ring (Installed on shock)	2
5	99055000	Locking Ring Set Screw (Installed on shock)	2
6	90001639	Mustang Trunnion (preassembled in shock)	4
7	90002312	2" Aluminum Stud Top Base	2
8	90001904	Bottom Delrin Ball	2
9	90001903	Top Delrin Ball	2
10	90001902	Delrin Ball Aluminum Top Cap	2
11	99562003	9/16"-18 Thin Nylok Nut	2
12	210-35-120-0	Adjuster Knob - (90009988 assembly)	2
13	90009969	#4-40 X 1/4" SS, 18-8 Pan Head Torx Cap - (90009988 assembly)	2
14	90002356	Upper ShockWave Mount	2
15	90003357	Aluminum Top Cover Plate	2
16	90001634	Trunnion Locking Rings (preassembled in shock)	4
17	90009936	Trunnion/Bushing Shims (preassembled in shock)	4
18	70009554	Poly Bushing (preassembled in shock)	4
	99371004	3/8"-16" X 1 1/4" Hex Bolt	4
	99372002	3/8"-16 Nylok Nut	4
	99373003	3/8" SAE Flat Washer	8

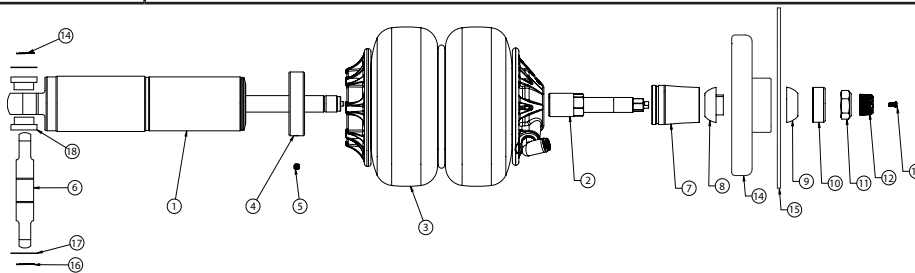

WARNING: ATTEMPTING TO REMOVE THE AIR FITTING WILL DAMAGE IT AND VOID THE WARRANTY.

Hardware Kit..... #99010195

QTY	Part Number	Description
UPPER PLATE MOUNTING		
6	99371027	5/8"-18 Nylok Nut
6	99621010	5/8"-18 x 4" Hex Bolt
6	99623001	5/8" SAE Flat Washer

QTY	Part Number	Description
SHOCK MOUNT TO BODY		
6	99501050	1/2"-13 X 2 1/2" Hex Bolt
6	99623010	1/2"-13 Nylok Nut
6	99561004	1/2" SAE Flat Washer
1	90002263	Red Loctite



ShockWave Installation

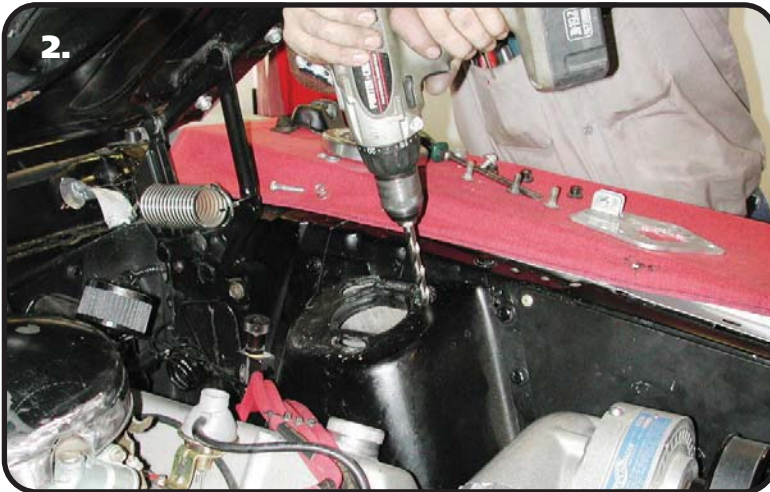

1. Install the Ridetech StrongArms. Also, it is easier to install the ShockWave with the coil spring shield removed.

2. We recommend drilling the holes in the large area of the key hole openings to 3/8". Do this for each key hole in the driver and passenger shock towers.



3. Slip the 3/8"-16 x 1" carriage bolts into the slots of the shock tower before bolting in the aluminum mount. **You can NOT slip the carriage bolts in with the upper mount bolted in place.**



4. Hold the aluminum upper mount against the bottom of the shock tower lining up the threaded holes with the holes drilled out in the shock tower.



ShockWave Installation



5. Install a 5/16" split lock washer & 5/16" SAE flat washer on each of (3) 5/16"-18 x 1" button head cap screws. Apply red loctite to the threads of each of the bolts. Hold the lower mount in position and thread the mounting bolts into the (3) mounting holes. Torque the bolts to 13 ft-lbs.



6. Lay the upper plate on top of the shock tower with the ShockWave mount protruding through the large center hole.



7. Install the export brace on the bolts sticking through the top plate. Install a 3/8" SAE flat washer & 3/8"-16 nylok nut on the threads of each of the bolts. Torque the nylok nuts to 15 ft-lbs.



ShockWave Installation

8.

1. Stud top aluminum base
2. Delrin ball lower half
3. Delrin ball upper half
4. Aluminum cap
5. 9/16" SAE Nylok jam nut
6. Threaded stud (screwed onto shock shaft)
7. Rebound adjusting knob
8. Screw

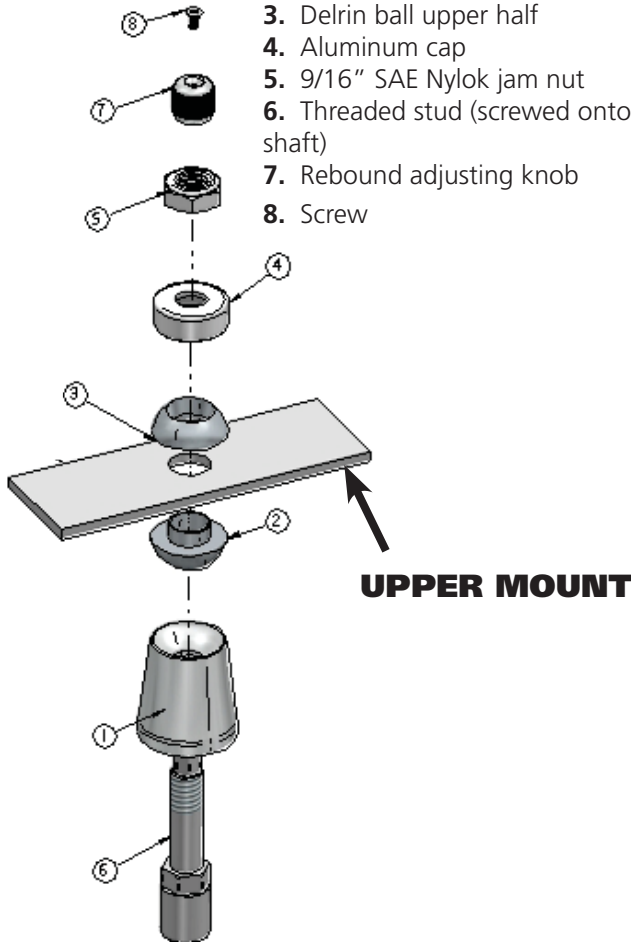

Note: The airline must also be routed at this time.

8. The air fitting location can be rotated by twisting the bellow assembly separate of the shock. Place the Shockwave into the coil spring pocket with the stud sticking through the OEM shock hole. See assembly **Diagram 8**.

1. Stud top aluminum base

2. Delrin ball lower half

UPPER MOUNT

3. Delrin ball upper half

4. Aluminum cap

5. 9/16" SAE Nylok jam nut

6. Threaded stud (screwed onto shock shaft)

7. Rebound adjusting knob

8. Screw

TIGHTENING THE TOP 9/16"-18 NUT: SNUG THE NUT DOWN AGAINST THE TOP CAP. YOU NEED TO BE ABLE TO ARTICULATE THE SHOCK BY HAND. WE TORQUE THE NUT TO 80 INLBS USING A 7/8" CROWS FOOT WRENCH ON A TORQUE WRENCH.

9.



9. Bolt the trunnion to the top of the upper arm using two 3/8" x 1 1/4" bolts, nyloc, and flat washers. Torque to 30 ftlbs

10. Reattach the outer coil spring shield. A hole can be drilled into it to allow airline access to the Shockwave. Use a rubber grommet to prevent airline damage.

Check air spring clearance through full suspension travel. Allowing the air spring to rub will cause failure and is not a warrantable situation.

11. Ride height should be around 90 psi but will vary to vehicle weight and driver preference.



Notes and Care of your Shockwaves

NOTES:

WARNING: ATTEMPTING TO REMOVE THE AIR FITTING WILL DAMAGE IT AND VOID THE WARRANTY.

TIGHTENING THE TOP 9/16"-18 NUT: SNUG THE NUT DOWN AGAINST THE TOP CAP. YOU NEED TO BE ABLE TO ARTICULATE THE SHOCK BY HAND.

You can clock the airfitting location on the ShockWave by turning the AirSpring assembly of the shock. Make sure the fitting doesn't contact the frame.

When cutting the airline, use a razor blade. The cut needs to be a clean cut and square for the airline to seal properly.

The Locking ring on the shock is NOT adjustable. These rings are set at the factory to optimize the AirSpring stroke with the shock stroke.

The care and feeding of your new ShockWaves

1. Although the ShockWave has an internal bumpstop, **DO NOT DRIVE THE VEHICLE DEFLATED RESTING ON THIS BUMPSTOP. DAMAGE WILL RESULT.** The internal bumpstop will be damaged, the shock bushings will be damaged, and the vehicle shock mounting points may be damaged to the point of failure. This is a non warrantable situation.
2. Do not drive the vehicle overinflated or "topped out". Over a period of time the shock valving will be damaged, possibly to the point of failure. This is a non warrantable situation! If you need to raise your vehicle higher than the ShockWave allows, you will need a longer unit.
3. The ShockWave is designed to give a great ride quality and to raise and lower the vehicle. **IT IS NOT MADE TO HOP OR JUMP!** If you want to hop or jump, hydraulics are a better choice. This abuse will result in bent piston rods, broken shock mounts, and destroyed bushings. This is a non warrantable situation.
4. Do not let the ShockWave bellows rub on anything. Failure will result. This is a non warrantable situation.
5. The ShockWave product has been field tested on numerous vehicles as well as subjected to many different stress tests to ensure that there are no leakage or durability problems. Failures have been nearly nonexistent unless abused as described above. If the Shockwave units are installed properly and are not abused, they will last many, many years. ShockWave units that are returned with broken mounts, bent piston rods, destroyed bumpstops or bushings, or abrasions on the bellows will not be warrantied.



Shock Adjustment

Shock Adjustment 101- Single Adjustable

Rebound Adjustment:

How to adjust your new shocks.

The rebound adjustment knob is located on the top of the shock absorber protruding from the eyelet.

You must first begin at the ZERO setting, then set the shock to a soft setting of 20.



-Begin with the shocks adjusted to the ZERO rebound position (full stiff). Do this by rotating the rebound adjuster knob clockwise until it stops.



-Now turn the rebound adjuster knob counter clock wise 20 clicks. This sets the shock at 20. (settings 21-24 are typically too soft for street use).

Take the vehicle for a test drive.



-if you are satisfied with the ride quality, do not do anything, you are set!



-if the ride quality is too soft increase the damping effect by rotating the rebound knob clock wise 3 clicks.

Take the vehicle for another test drive.



-if the vehicle is too soft increase the damping effect by rotating the rebound knob clock wise 3 additional clicks.



-If the vehicle is too stiff rotate the rebound adjustment knob counter clock wise 2 clicks and you are set!

Take the vehicle for another test drive and repeat the above steps until the ride quality is satisfactory.

Note:

One end of the vehicle will likely reach the desired setting before the other end. If this happens stop adjusting the satisfied end and keep adjusting the unsatisfied end until the overall ride quality is satisfactory.