



Part # 12110201 - 1967-1970 Cougar HQ Series CoilOver System

Recommended Tools

Front Components:

- 12103510 Front CoilOvers
- 12103699 Upper StrongArms
- 12102899 Lower StrongArms
- 12109120 Front SwayBar

Rear Components:

- 12117199 Rear 4Link System
- 12106510 Rear Coilover Instructions

Miscellaneous Components:

- 85000000 Spanner Wrench

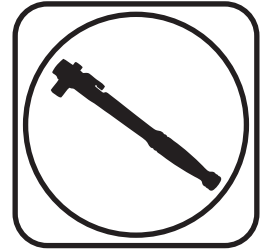

1967-1970 Ford Mustang Coilover Installation Instructions

Table of contents

| | | |
|-------|------------|--------------------------------|
| Pages | 2-8..... | Front CoilOvers |
| Pages | 9-11..... | Upper StrongArms |
| Pages | 12-16..... | Lower StrongArms |
| Pages | 17-19..... | Front Sway Bar |
| Pages | 20-28..... | Rear 4-Link |
| Pages | 29-30..... | Rear CoilOvers |
| Pages | 31-32..... | Coil Spring & Shock Adjustment |





Part # 12103510 - 67-70 Mustang/Cougar Front HQ CoilOver, for StrongArms

Recommended Tools

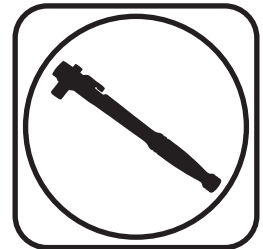
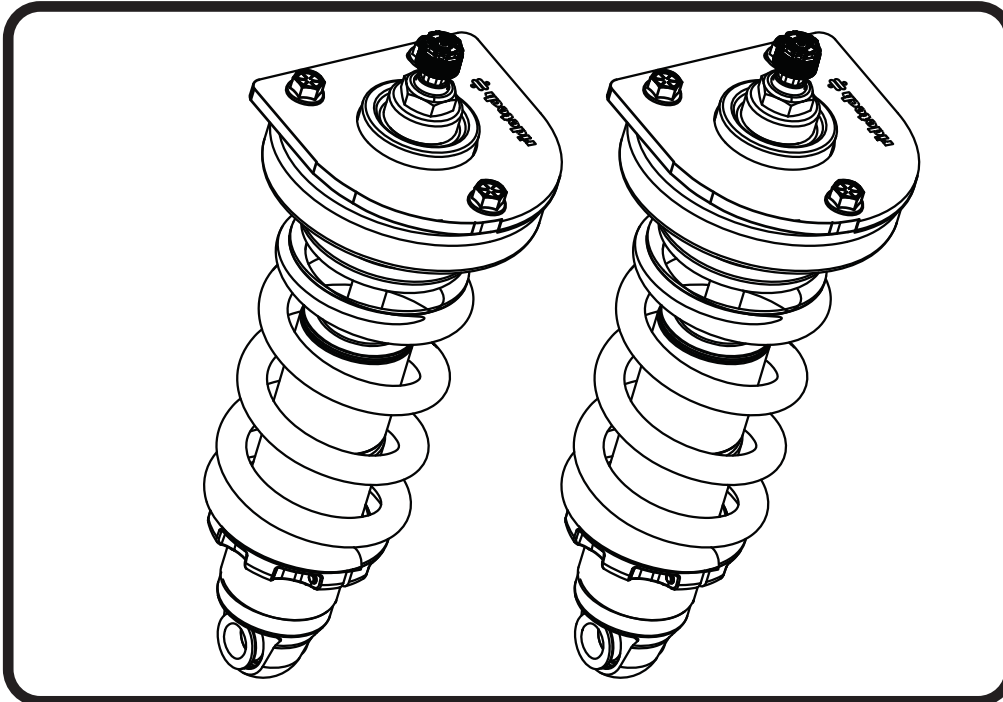

1967-1970 Mustang/Cougar HQ Series Front CoilOvers

Installation Instructions

THESE COILOVERS ARE DESIGNED TO BE USED WITH RIDETECH STRONGARMS

Table of contents

| | |
|---------------|--------------------------|
| Page 3..... | Included Components |
| Page 4-5..... | Upper Mount Installation |
| Page 6..... | CoilOver Assembly |
| Page 7..... | CoilOver Installation |
| Page 8..... | CoilSpring Adjusting |

CoilOver Dimensions:

Mount to Mount:

| | |
|--------------|--------|
| Compressed: | 9.40" |
| Ride Height: | 11.00" |
| Extended: | 11.90" |

www.ridetech.com



REV1 6/3/21



Major ComponentsIn the box

| Item # | Part # | Description | QTY |
|--------|-----------------|---------------------------------|-----|
| 1 | 59080700 | CoilSpring 8" 700lb | 2 |
| 2 | 982-10-802 | 2.9" Stroke HQ Series Shock | 2 |
| 3a | 803-00-199(kit) | Lower Spring Adjuster Nut | 2 |
| 3b | 803-00-199(kit) | Adjuster Nut Locking Screw | 2 |
| 3c | 803-00-199(kit) | CoilSpring Plate Retaining Ring | 2 |
| 3d | 803-00-199(kit) | Upper CoilSpring Retainer | 2 |
| 4 | 70010828 | Delrin Spring Washer | 4 |
| 5 | 90009988(kit) | 2.00" Stud Adjuster Assembly | 2 |
| 6 | 70012160 | 2.00" Metering Rod | 2 |
| 7 | 90002312 | 2.00" Stud Top Base | 2 |
| 8 | 90001903 | Delrin Ball Lower Half | 2 |
| 9 | 90001904 | Delrin Ball Top Half | 2 |
| 10 | 90001902 | Delrin Ball Upper Cap | 2 |
| 11 | 210-35-120-0 | Shock Adjuster Knob | 2 |
| 12 | 90009969 | Adjuster Knob Retaining Screw | 2 |
| 13 | 90001994 | 5/8" ID Bearing | 2 |
| 14 | 90001995 | Bearing Snap Ring | 4 |
| 15 | 90003201 | Upper Shock Mount | 2 |
| 16 | 90003202 | Upper Shock Mount Top Plate | 2 |
| 17 | 99562003 | 9/16-18" Nylok Nut | 2 |

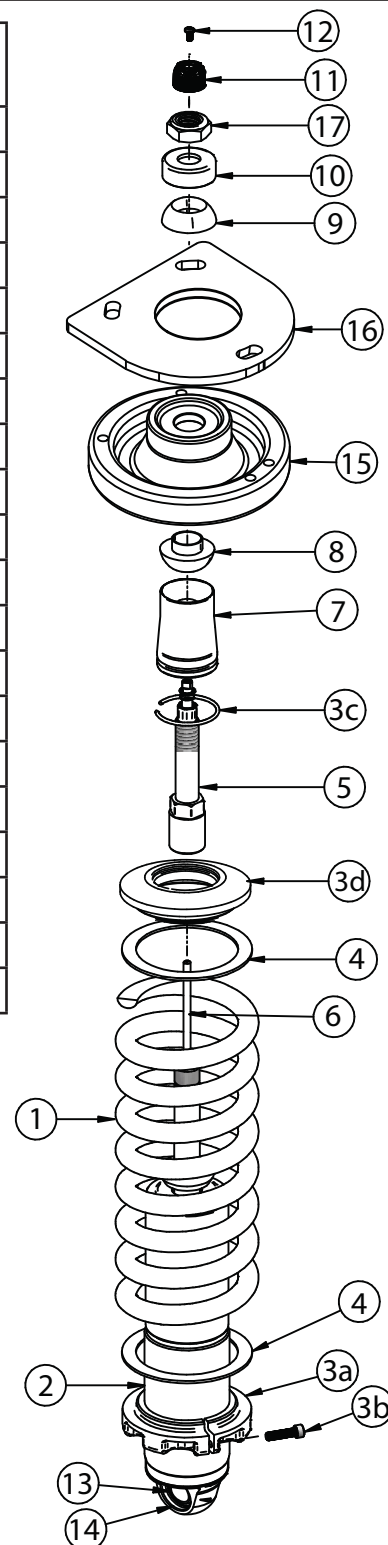

Hardware Kit..... #99010195

| QTY | Part Number | Description |
|-----------------------------|-------------|-----------------------------|
| UPPER PLATE MOUNTING | | |
| 6 | 99371027 | 3/8"-16" x 1" Carriage Bolt |
| 6 | 99373003 | 3/8" SAE Flat Washer |
| 6 | 99372002 | 3/8"-16 Nylok Nut |
| SHOCK MOUNT TO BODY | | |
| 6 | 99311044 | 5/16"-18 x 1" Button Head |
| 6 | 99313002 | 3/8" SAE Flat Washer |
| 6 | 99313003 | 5/16" Split Lock Washer |
| 1 | 90002263 | Red Loctite |



Upper Mount Installation



1. Install the Ridetech StrongArms. Also, it is easier to install the ShockWave with the coil spring shield removed.

2. We recommend drilling the holes in the large area of the key hole openings to 3/8". Do this for each key hole in the driver and passenger shock towers.



3. Slip the 3/8"-16 x 1" carriage bolts into the slots of the shock tower before bolting in the aluminum mount. **You can NOT slip the carriage bolts in with the upper mount bolted in place.**



4. Hold the aluminum upper mount against the bottom of the shock tower lining up the threaded holes with the holes drilled out in the shock tower.



Upper Mount Installation



5. Install a 5/16" split lock washer & 5/16" SAE flat washer on each of (3) 5/16"-18 x 1" button head cap screws. Apply red loctite to the threads of each of the bolts. Hold the lower mount in position and thread the mounting bolts into the (3) mounting holes. Torque the bolts to 13 ft-lbs.



6. Lay the upper plate on top of the shock tower with the ShockWave mount protruding through the large center hole.



7. Install the export brace on the bolts sticking through the top plate. Install a 3/8" SAE flat washer & 3/8"-16 nylok nut on the threads of each of the bolts. Torque the nylok nuts to 15 ft-lbs.



CoilOver Assembly

8.

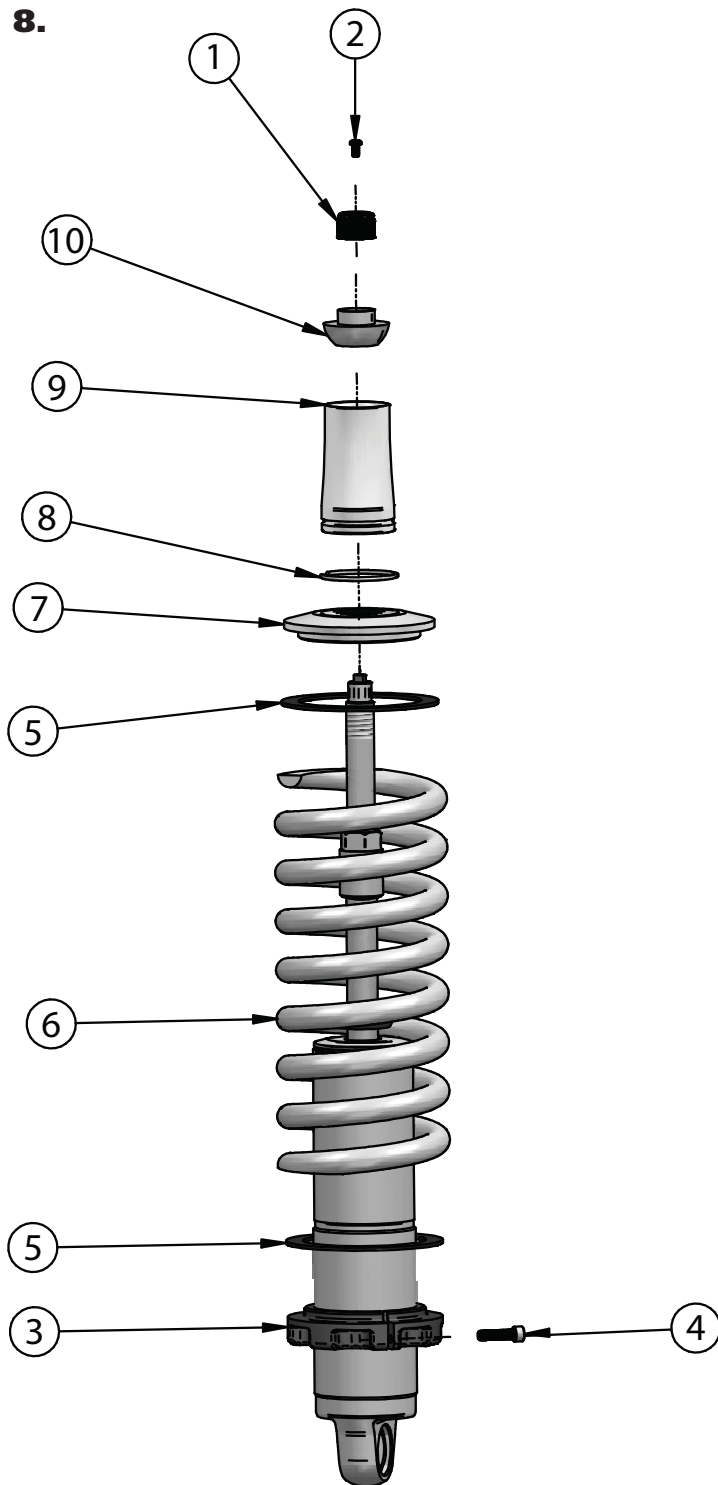

8. To Assemble the CoilOver you need to:

a. Remove Screw (2) from center of Adjustment Knob (1) and remove Adjustment Knob.

b. Remove Nylok Nut, Delrin Upper Cap, Delrin Upper and Lower Balls, along with the base from the Coilover stud.

c. Thread Adjuster Nut (3) onto the CoilOver body. Once it is threaded on the shock body, lightly thread in the locking screw (4) into the Adjuster Nut.

d. Install a Delrin Spring Washer (5) onto the Adjuster Nut.

e. Slide the CoilSpring (6) onto the CoilOver.

f. Install another Delrin Spring Washer (5) on top of the CoilSpring.

g. Install the Upper CoilSpring Plate (7) onto the CoilSpring.

h. Install the CoilSpring Retaining Ring (8) onto the Stud Top Base (9). It fits into the groove in the base.

i. Slide the Stud Top Base onto the shock until it bottoms out on the stud. It may be necessary to thread the Adjuster Nut down the shock body (to lower the spring) if the base will not slide all the way down onto the stud.

k. Slide the Lower Delrin Ball (10) (it has the collar sticking up around the center hole) on to the Stud Top.

Repeat on second CoilOver.



CoilOver Installation

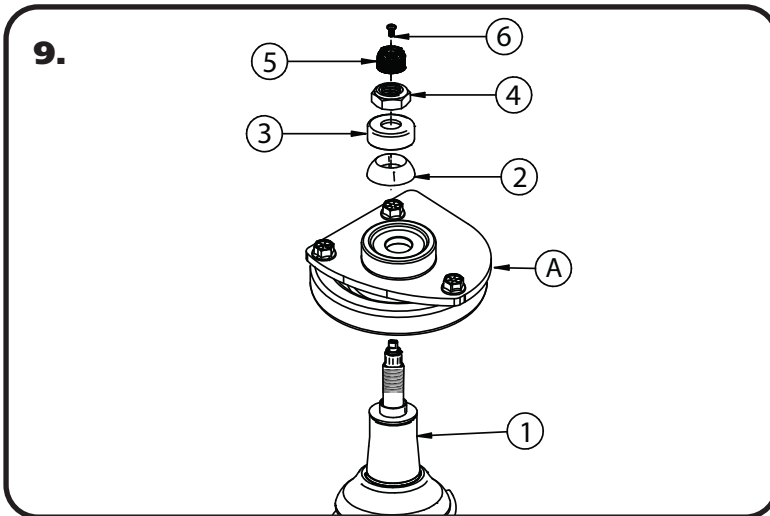

9. Place the CoilOver into the coil spring pocket with the stud sticking through the Aluminum upper mount (A). See assembly **Diagram 9**.

- 1. CoilOver Assembly
- A. Upper Shock Mount
- 2. Delrin ball upper half
- 3. Aluminum cap
- 4. 9/16" SAE Nylok jam nut
- 5. Rebound adjusting knob
- 6. Screw

TIGHTENING THE TOP 9/16"-18 NUT: SNUG THE NUT DOWN AGAINST THE TOP CAP. YOU NEED TO BE ABLE TO ARTICULATE THE SHOCK BY HAND. WE TORQUE THE NUT TO 80 INLBS USING A 7/8" CROWS FOOT WRENCH ON A TORQUE WRENCH.



10. Install the a Bearing Spacer in each side of the Bearing. The SMALL part of the spacer inserts into the Inside Diameter of the shock bearing. Raise the lower arm up to the CoilOver and bolt them together using the 1/2" x 2 1/4", & Nylok Nuts supplied with the StrongArms. Torque to 50 ftlbs.

11. Reattach the outer coil spring shield.



CoilSpring Adjustment

12. Preload the springs of the CoilOver 1" to start. **Steps 12a - 12e** will assist you with preloading the coil spring. You may need to adjust the amount of preload in the spring, but this will be determined after the vehicle has been sat on the ground.

12a. Verify the adjuster nut locking screw is installed in the adjuster nut, but not tight.

12b. Thread the spring adjuster nut up the shock body until it is snug against the spring. You should NOT be able to move the spring up and down on the shock (0 preload). Verify the dropped upper coil spring cap is seated correctly on the upper shock stud.

12c. Measure from the bottom of the adjuster nut to the flat of the shock. You may want to write the measurement down.

12d. Using a spanner wrench, thread the adjuster up the shock an additional 1" (from the measurement you took in step 2) to preload the spring.

12e. Lock the adjusting nut in place by tightening the adjuster nut locking screw.

13. Reinstall the front wheels and tires and set the front of the vehicle back on the ground.

14. After entire weight of vehicle is on the wheels, jounce the suspension and roll the car forward and backward to alleviate suspension bind. **THIS IS NECESSARY BEFORE MEASURING RIDE HEIGHT.**

15. If you determine you need to adjust the ride height of the front suspension after getting the vehicle on the ground, **Steps 15a - 15e** will assist you in adjusting the ride height.

15a. Raise the vehicle and support it by the frame, allowing the suspension to hang freely. You do NOT need to remove the front wheels, but you may want to turn the steering wheel to gain better access to the CoilOver.

15b. Loosen the locking screw in the adjuster nut, but do not remove the locking screw.

15c. Measure from the bottom of the adjuster nut to the flat of the shock. You may want to write the measurement down.

15d. Using a spanner wrench, thread the adjuster up or down the shock to obtain the correct ride height. One complete revolution of the adjuster nut is approximately 1/8" at the wheel. Threading the adjuster nut up the shock will raise the ride height, threading it down will lower the ride height.

15e. Lock the adjusting nut in place by tightening the adjuster nut locking screw.

16. Turn the steering wheel until the front wheels are straight and set the front of the vehicle back on the ground.

17. After entire weight of vehicle is on the wheels, jounce the suspension and roll the vehicle forward and backward to alleviate suspension bind. **THIS IS NECESSARY BEFORE MEASURING RIDE HEIGHT.**

18. Recheck your ride height. If you need to readjust, repeat **Steps 15-17.**



Part # 12103699

1967-1970 Mustang/Cougar Front Upper StrongArms



Recommended Tools

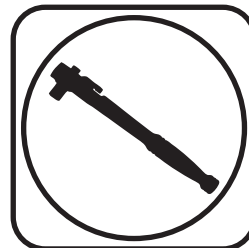
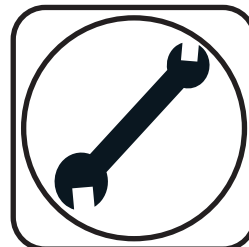

1967-1970 Mustang/Cougar Upper StrongArms Installation Instructions

| | |
|--------------------------|------------------------------|
| Table of contents | |
| Page 10..... | Upper Control Arm Components |
| Page 11..... | Installations |

THESE CONTROL ARMS ARE DESIGNED TO BE USED WITH RIDETECH COILOVERS/SHOCKWAVES AND RIDETECH LOWER STRONGARMS.

THESE CONTROL ARMS HAVE THE "SHELBY MOD" BUILT INTO THE CROSS SHAFT. THIS MOD LOWERS THE CONTROL ARM PIVOT FOR BETTER CAMBER GAIN DURING SUSPENSION TRAVEL.



Upper Control Arm ComponentsIn the box

| Item # | Part Number | Description | QTY |
|--------|--------------|-------------------------------------|-----|
| 1 | 90000115 | Upper Control Arm | 2 |
| 2 | 90000930 kit | Upper Ball Joint Kit - Moog # K8036 | 2 |
| 3 | 90000931 | Billet Cross Shaft | 2 |
| 4 | 90001589 | Heim End - 3/4"-16 thread x 5/8" ID | 4 |
| 5 | 90000113 | Alignment Shim | 2 |
| 6 | 99752004 | 3/4"-16 Jam Nut | 2 |
| 7 | 99621021 | 5/8"-18 x 2" Gr.8 bolt | 4 |
| 8 | 99623002 | 5/8" Gr. 8 Lock Washer | 4 |
| 9 | 99623001 | 5/8" SAE Gr. 8 Flat Washer | 4 |
| 10 | 99501010 | 1/2"-20 x 2 1/4" Gr.8 Bolt | 2 |
| 11 | 99502003 | 1/2"-20 Thin Nylok Nut | 2 |
| 12 | 99501003 | 1/2"-13 x 2 1/2" Gr.5 Bolt | 4 |
| 13 | 99503001 | 1/2" SAE Flat Washer | 8 |
| 14 | 99503002 | 1/2" Lock Washer | 4 |
| 15 | 99502006 | 1/2"-13 Hex Nut | 4 |

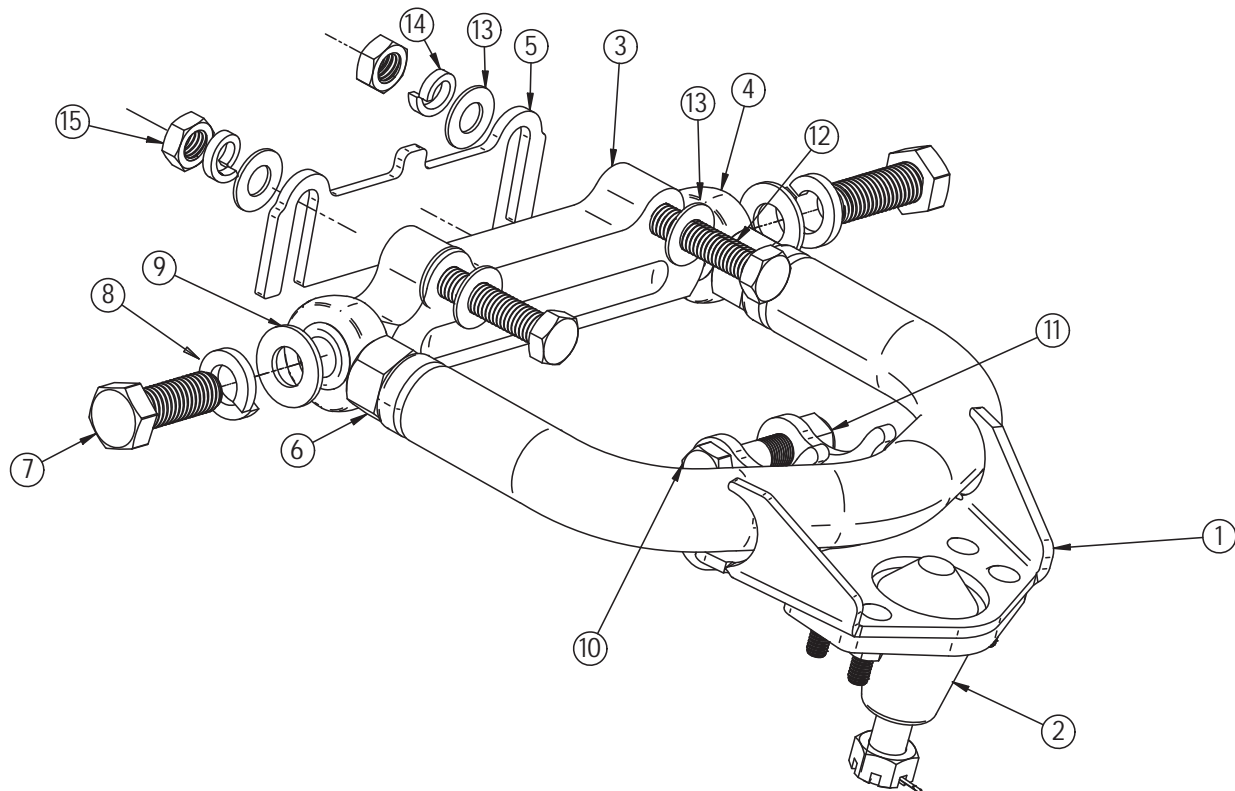



Installation

1. Remove the shocks, coil springs & upper control arms from the car. If you are replacing the lower control arms, remove them too. Refer to a Factory Service Manual for the proper method.



THE UPPER CONTROL ARMS ARE IDENTICAL, SO THEY WILL FIT EITHER SIDE.

2. Bolt the upper StrongArm to the body using $\frac{1}{2}$ " x $2 \frac{1}{2}$ " bolts, flat washers and lock washers. A shim is supplied and may need to be installed between the body and the arms to achieve proper alignment. Torque to 75 ft-lbs.

Note: The upper arm mounting holes on many cars have been redrilled 1" lower. This is done to improve the handling. Our cross shaft has the drop built into it, make sure to use the factory mounting holes.



3. Attach the Spindle to the control arms.

Torque Specs:

Upper Ball Joint - 60 ftlbs and tighten to line up cotter pin.

Install the Cotter Pin after tightening the ball joint nut.



4. Attach the Shockwave to the upper StrongArm using a $\frac{1}{2}$ " x $2 \frac{1}{4}$ " bolt and Nylok nut. Torque to 75 ft-lbs.

Note: The arms are preset at the factory so the alignment should be close, but the vehicle must be aligned before driving.

Suggested Alignment Specs:

| | | |
|---------|---------|-----------------------|
| Camber: | Street: | -.5 degrees |
| Caster: | Street: | +3.0 to + 5.0 degrees |
| Toe: | Street: | 1/16" to 1/8" toe in |



Part # 12102899

1967-1970 Mustang/Cougar Front Lower StrongArms

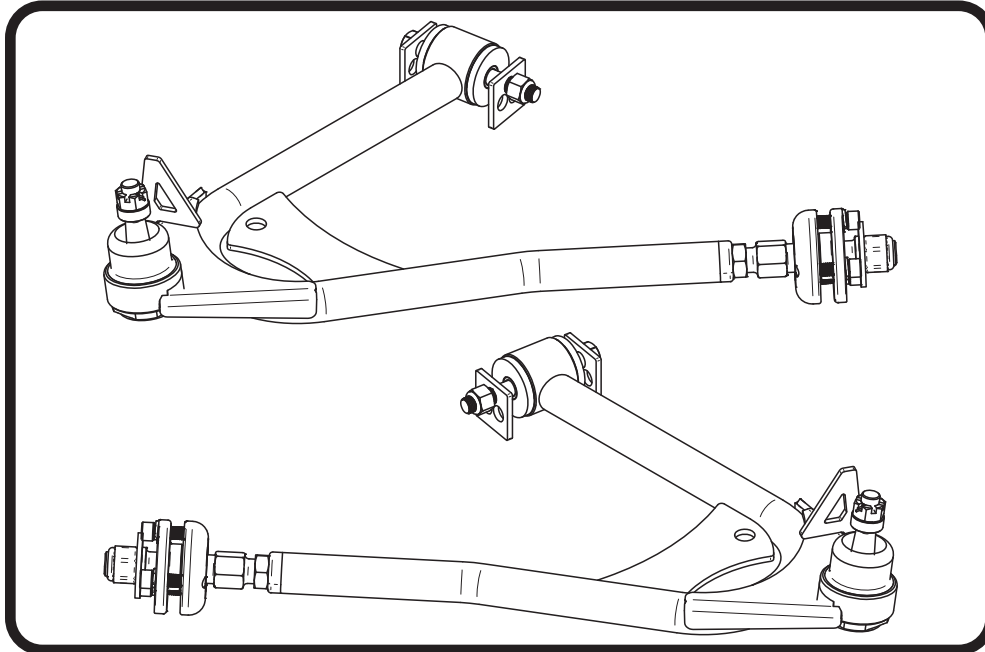

Recommended Tools

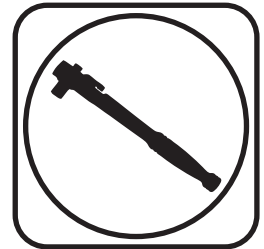

1967-1970 Mustang/Cougar Lower StrongArms

Installation Instructions

Table of contents

Page 13..... Lower Control Arm Components

Page 14-16..... Installations

THESE CONTROL ARMS ARE DESIGNED TO BE USED WITH RIDETECH COILOVERS/SHOCKWAVES AND RIDETECH UPPER STRONGARMS.



Upper Control Arm ComponentsIn the box

| Item # | Part Number | Description | QTY |
|--------|--------------|--------------------------------------|-----|
| 1 | 90000110 | Lower Control Arm - Driver - (Shown) | 1 |
| 1 | 90000111 | Lower Control Arm- Passenger | 1 |
| 2 | 90000895 kit | Ball Joint Kit - Moog # K772 | 2 |
| 3 | 90001086 | Bushing Half | 4 |
| 4 | 90000108 | Inner Bushing Sleeve | 2 |
| 5 | 90000732 | Bearing Stud - set to 2 15/16" | 2 |
| 6 | 99752004 | 3/4"-16 Jam Nut | 2 |
| 7 | 90000734 | Pivot Bearing Housing | 2 |
| 8 | 90001045 | Pivot Bearing | 2 |
| 9 | 90000109 | Pivot Bearing Retaining Plate | 2 |
| 10 | 90000733 | Aluminum Pivot Bearing Spacer | 2 |
| 11 | 90002283 | Ball Joint Castle Nut Spacer | 2 |
| 12 | 90000112 | Eccentric Eliminator | 4 |
| 13 | 99752001 | 3/4"-16 Lock Nut | 2 |
| 14 | 99753002 | 3/4"x 2" Flat Washer | 2 |
| 15 | 99501034 | 1/2"-13 x 4 1/2" Gr.8 Bolt | 2 |
| 16 | 99503014 | 1/2" SAE Flat Washer | 8 |
| 17 | 99502009 | 1/2"-13 Nylok Nut | 2 |
| 18 | 99371019 | 3/8"-16 x 1 1/2" SHCS | 6 |
| 19 | 99373006 | 3/8" Split Lock Washer | 6 |

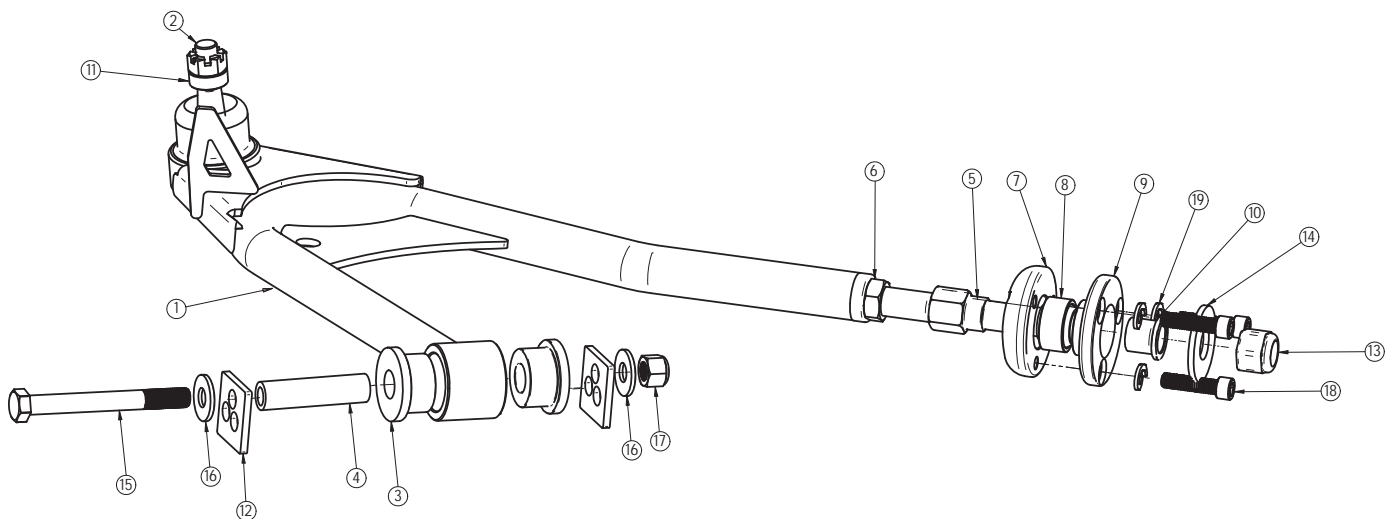



Getting Started.....

Congratulations on your purchase of the Ridetech Mustang StrongArms. These StrongArms have been designed to give your Mustang excellent handling along with a lifetime of enjoyment. Some of the key features of the StrongArms: Ball Joint angles have been optimized for the lowered ride height. The Geometry has been optimized for excellent handling, and drive ability. The control arm is a 1-piece control arm to eliminate the strut rod and bushing.

Note: These control arms are designed for use with the Ridetech ShockWaves or CoilOvers. **The factory shocks and springs will not fit these arms.**

Installation

1. Raise and support vehicle at a safe, comfortable working height. Let the front suspension hang freely.
2. Remove the lower control arms, and the strut rods.

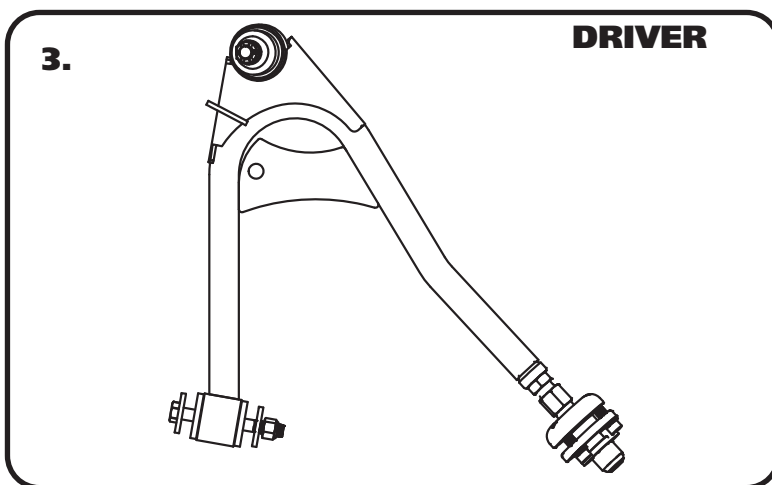

3. The control arms are marked "D" for Driver and "P" for Passenger. The control arms will be installed in the car with the ball joint pin pointing up.



4. Be sure to remove the outer bushing sleeve from the strut rod frame mount.

Note: Remove any excess undercoating or rust.



Control Arm Installation



5. Using the bearing retainer as a template; drill three 3/8" holes in the frame to secure the assembly. Use three 3/8" x 1 1/4" SHCS and lock washers to secure the assembly. Torque to 30 ft-lbs.

Note: The hole in the frame may need to be buffed to allow bearing retainer plate to slide in.



6. Slide the stud through the bearing, then slide the aluminum spacer over the stud with the larger end toward the front of the car. Secure the assembly with a 3/4" Nylok Nut and flat washer. Use **Images 6 & 7** as a guide.

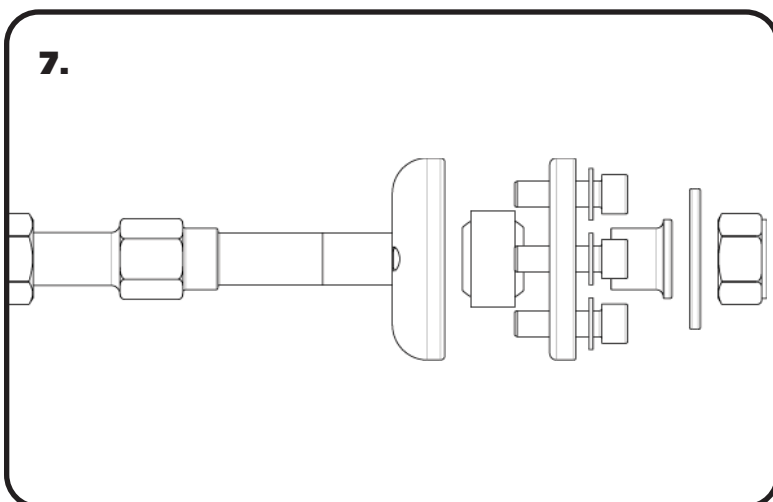

7. The front leg of the lower arm will attach to the frame in place of the strut rod. Refer to **Diagram 7** for assembly order. Torque the 3/4"-16 nut to 75 ft-lbs.



Control Arm Installation



8. Eccentric eliminator plates are included, one must be installed on each side of the frame. Start out with it in the center, make sure both plates are in the same position. Attach the other end of the lower control arm to the factory frame mount using a 1/2" x 4 1/2" bolt and Hex nut. Torque to 75 ft-lbs.



9. Slide the ball joint boot over the ball joint, then place the spindle over the ball joint stud. A ball joint spacer will be necessary to align the castle nut with the cotter pin hole. Grease ball joint. Attach the spindle to the control arms.

Torque Specs:

Lower Ball joint - 70 ft-lbs and tighten to line up cotter pin.

Install the cotter pin after tightening the ball joint nut.

10. Lubricate control arm bushing with Lithium grease.

Suggested Alignment Specs:

| | |
|---------|-------------------------------|
| Camber: | Street: -0.5 degrees |
| Caster: | Street: +3.0 to + 5.0 degrees |
| Toe: | Street: 1/16" to 1/8" toe in |



Part # 12109120 - 1967-1970 Mustang/Cougar Front Sway Bar



Recommended Tools



1967-1970 Mustang/Cougar Front Sway Bar Installation Instructions

Table of contents

Page 18..... Included Components and Hardware List

Page 18-19.... SwayBar Installation

Hardware Torque Specifications

| | |
|--------------|----------|
| M10-1.5..... | 37 ftlbs |
| 3/8"-16..... | 35 ftlbs |

Major ComponentsIn the box

| Part # | Description | QTY |
|--------------------------|----------------------------|-----|
| 90002952 | SwayBar | 1 |
| 90002953 | Bushing Strap Spacer | 2 |
| 70015013 | Lined SwayBar Bushing | 2 |
| 90001344 | SwayBar Bushing Strap | 2 |
| 90001258 | SwayBar End Link T-Bushing | 4 |
| END LINK ASSEMBLY | | |
| 90001256 | 90 Degree End Link Adapter | 2 |
| 90002571 | 90 Degree End Link | 2 |
| 99375008 | 3/8"-16 x 3" Threaded Stud | 2 |
| 90002930 | End Link Kit | 2 |

HARDWARE KIT 99010213

| QTY | Part Number | Description |
|-----|-------------|--|
| 4 | 99371019 | 3/8"-16 x 1 1/2" Socket Head Cap Screw |
| 4 | 99373002 | 3/8" SAE Flat Washer |
| 4 | 99372001 | 3/8"-16 Nylok Nut |
| 4 | 99373020 | 3/8" ID x 5/8" OD Flat Washer |

Getting Started.....

Note: This sway bar kit utilizes a anti-friction lining in the sway bar bushing. The lining allows the sway bar to move freely and quietly in the bushing. No lubrication is required.

1. Jack the vehicle up to a safe working height and support with jack stands. Make sure the jack stands are stable before working under the car.
2. Remove the stock sway bar.



3. Open the sway bar bushing at the split and slip it **OVER** the sway bar. Do this for both bushings.



4. Slip the bushing straps over the swaybar bushings.



5.

5. Install the sway bar in position in the car. The center of the bar should be to the front of the car. The outer arms of the sway bar will bend upward. Use **Picture 6** as a reference.

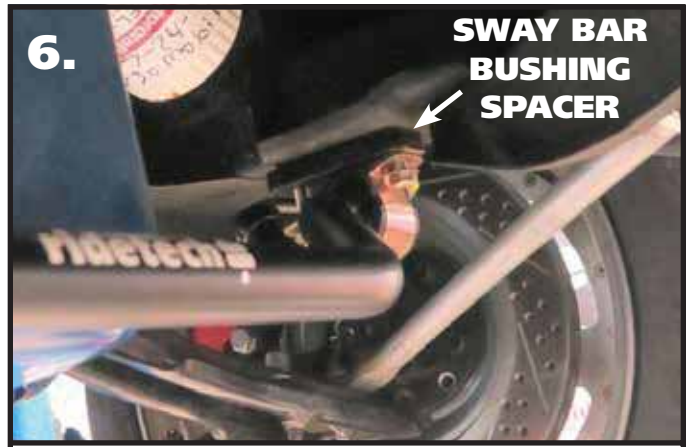

6.

SWAY BAR BUSHING SPACER

6. Install a $3/8"$ x $5/8"$ OD flat washer on each of the (4) $3/8"$ x $1/2"$ SHCS. The sway bar bushing spacer will be installed between the sway bar bushing and frame. Push the bar up to the frame, installing the spacer in place. Hold it in position and install (2) bolt/washers in each side. Install a $3/8"$ flat washer & $3/8"$ nylok nut on the bolts and snug the hardware.

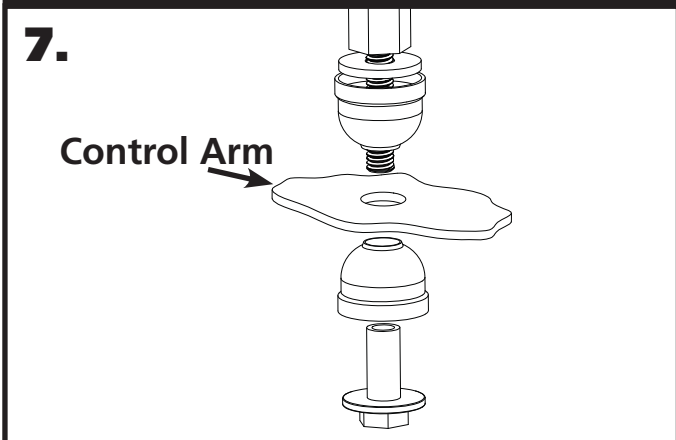

7.

Control Arm

7. Install the End Links using **Diagram 7** as a reference. Tighten the end link barrel nut until it is flush with the end of the bolt, and then tighten it 2 more complete rounds.



8.

8. Install a T-Bushing on each of the 90 degree end links. The t-bushings are installed with the large diameter against the shoulder of the end link.



9.

9. Insert the 90 degree end link/t-bushing into the swaybar end with the threads pointing toward the engine. Install a 2nd t-bushing with the small diameter into the swaybar. Install the nut and torque. Do this for both sides.

10. Torque the swaybar mounting hardware.



Part # 12117199 -1967-1970 Cougar Rear Bolt-in 4 Link

Recommended Tools

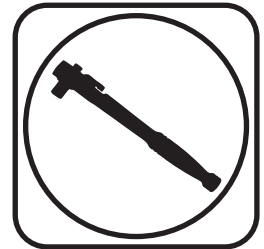
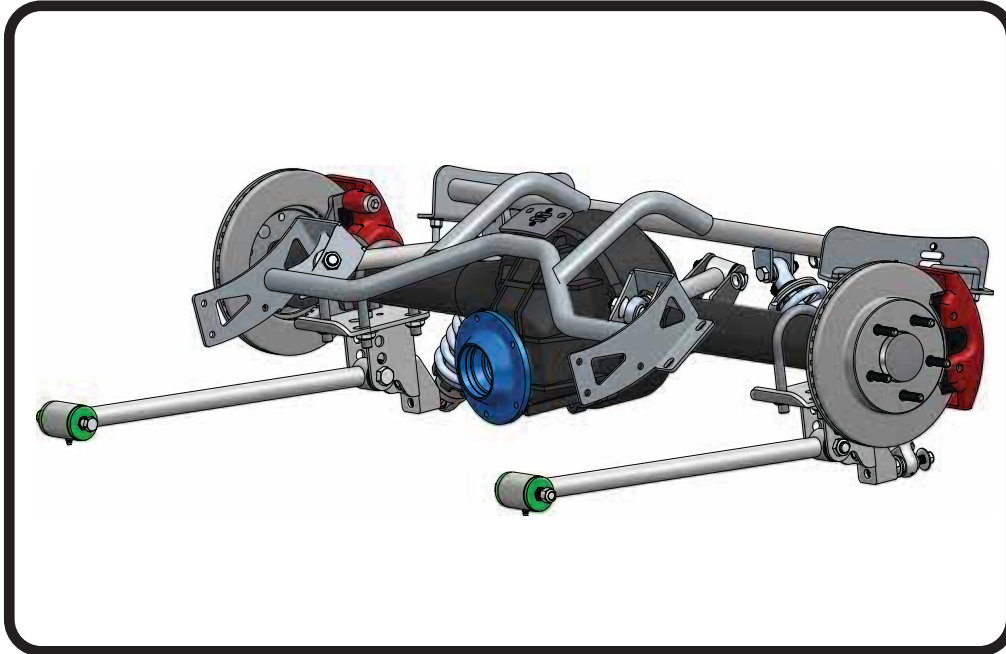

1967-1970 Cougar Rear Bolt-in 4 Link Installation Instructions

Table of contents

| | |
|--------------|---|
| Page 21..... | Included components |
| Page 22..... | Hardware List and Getting Started |
| Page 23..... | Cradle Installation |
| Page 24..... | Lower Axle Mount & Lower Bar Installation |
| Page 25..... | Setting Pinion Angle |
| Page 26..... | Upper Bar Axle Tab Installation |
| Page 27..... | Installing Axle Tabs |
| Page 28..... | Installing ShockWaves/CoilOvers |

NOTE: If your car is equipped with a differential that has the axle tubes swedged to 2 1/4", you will need (4) 99566009 u-bolts. See page 3.





Major ComponentsIn the box

| Item # | Part # | Description | QTY |
|---|----------|---|-----|
| 1 | 90002198 | Upper Cradle | 1 |
| 2 | 90001444 | Lower Axle Mount | 2 |
| 3 | 90002846 | Lower Bar Assembly - 24 5/8" center to center | 2 |
| 4 | 70013767 | Front Lower R-Joint Spacer | 4 |
| 5 | 90002844 | Upper Bar - 11 3/4" center to center | 2 |
| 6 | 70013364 | RH R-Joint Threaded Housing End (installed in upper bars) | 2 |
| 7 | 70011897 | Upper Bar Tab - Tall | 4 |
| 8 | 70012018 | Upper Bar Tab - Short | 2 |
| 9 | 90001624 | Aluminum Lower Shock Mount | 2 |
| 10 | 70002825 | Lower Shock Stud | 2 |
| 11 | 70013334 | R-Joint Spacers | 12 |
| 12 | 90002285 | Square U-Bolts | 7 |
| 13 | 99566001 | Axle U-Bolts | 4 |
| 14 | 99752004 | 3/4"-16 Jam Nut (installed on upper bar Heim) | 2 |
| | 90002067 | Lower Shock Spacers | 4 |
| | 70010694 | Bar Tab Setting Jig | 2 |
| R-Joint Components - (Installed in bar ends) | | | |
| | 70013279 | Retaining Ring | 8 |
| | 70013280 | Wavo Wave Spring | 8 |
| | 70013275 | R-Joint Center Ball | 8 |
| | 70013276 | R-Joint Composite Center Ball Cage | 8 |

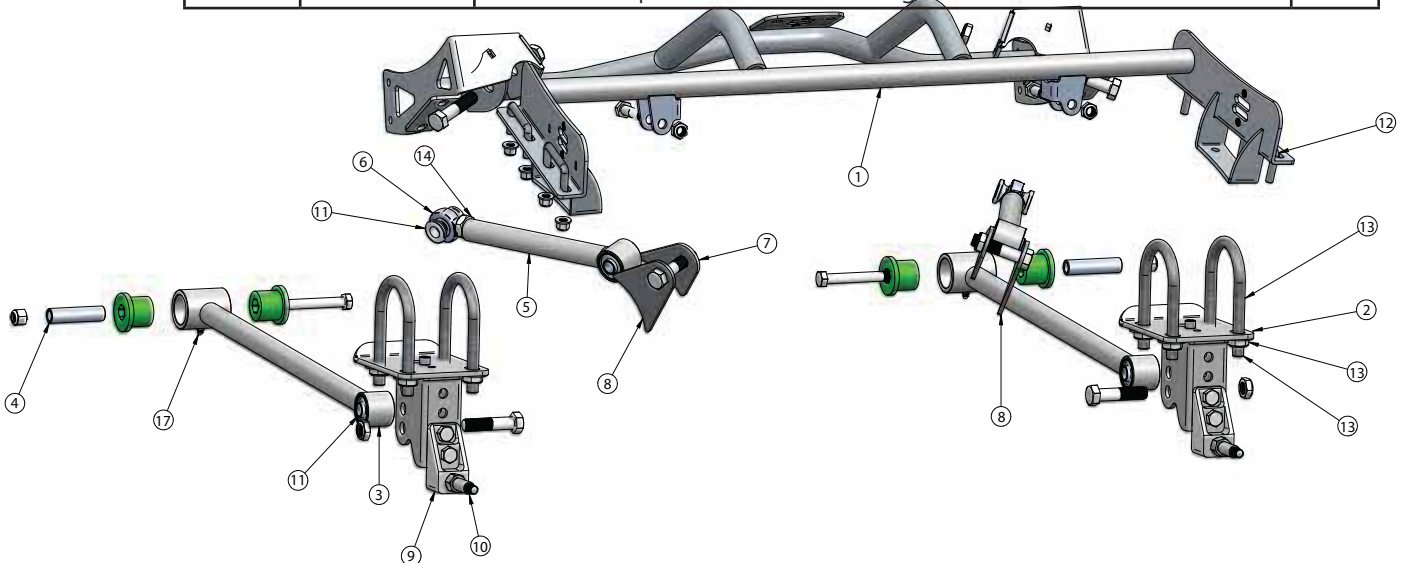



Hardware ListIn the box (Kit# 99010054)

| QTY | Part Number | Description | QTY | Part Number | Description |
|----------------------------------|-------------|------------------------------|-----------------------------------|-------------|---------------------------|
| 4-Link Bars to Mounts | | | U-bolts | | |
| 6 | 99621003 | 5/8" x 2 3/4" Gr. 8 Bolt | 8 | 99566003 | 9/16" SAE Flat Washer |
| 6 | 99622006 | 5/8" SAE Nylok Jam Nut | 8 | 99566002 | 9/16"-18 Hex Nut |
| Cradle to Car | | | Front Lower bar to Chassis | | |
| 14 | 99372002 | 3/8-16" Nylok Nut | 2 | 99501029 | 1/2"-20 x 6 1/2" Hex Bolt |
| 14 | 99373003 | 3/8" SAE Flat washer | 2 | 99501017 | 1/2"-20 x 4 1/2" Hex Bolt |
| 6 | 99373007 | 3/8"-16 Thread Forming Bolts | 2 | 99502002 | 1/2"-20 Nylok Nut |
| Shock Mount to Axle Mount | | | Bar Setting Jig | | |
| 2 | 99501007 | 1/2"-20 x 1 1/4" Hex Bolt | 2 | 99371001 | 3/8"-16 x 3/4" Hex Bolt |
| 2 | 99501009 | 1/2"-20 x 1 3/4" Hex Bolt | 2 | 99372004 | 3/8"-16 Hex Nut |
| 4 | 99502002 | 1/2"-20 Nylok Nut | Shock Stud | | |
| Shock to Cradle | | | 2 | 99432002 | 7/16"-20 Nylok Nut |
| 2 | 99501010 | 1/2"-20 x 2 1/4" Hex Bolt | 2 | 99433002 | 7/16" SAE flat Washer |
| 2 | 99502003 | 1/2"-20 Thin Nylok Jam Nut | 2 | 99623004 | 5/8" SAE Flat Washer |

R-JOINT SPACER INSTALLATION

Install the Spacers by inserting the SMALL side of the SPACER into the Center Pivot Ball. Push them in until they bottom out and stop.

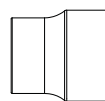
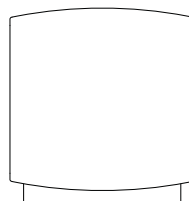
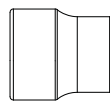

ALL OTHER R-JOINTS

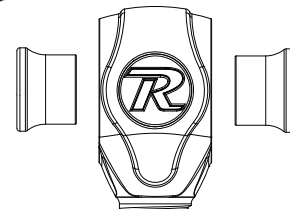

New R-Joints will be quite stiff (75-90 in/lbs breakaway torque) until they "break in" after a few miles of use. After the break in period they will move much more freely. Because the composite bearing race contains self lubricating ingredients, no additional lubrication is needed or desired. Any additional lubrication will only serve to attract more dirt and debris to the R-Joint and actually shorten its life.



SWEDGED AXLE TUBES! - IF YOUR CAR EQUIPPED WITH A DIFFERENTIAL THAT HAS THE ENDS OF THE AXLE TUBES SWEDGED TO 2 1/4", YOU WILL NEED DIFFERENT U-BOLTS. YOU WILL NEED (4) OF RIDETECH PART # 99566009.

Getting Started.....

Congratulations on your purchase of the Ridetech Rear 4-link System. This system has been designed to give your Mustang excellent handling along with a lifetime of enjoyment. Some of the key features of this system: Tune ability, Replaces the Leaf Springs, this allows the 4-Link to locate the rearend and the CoilOvers/ShockWaves to support the car.

Note: These system is designed for use with the Ridetech Shockwaves or CoilOvers. **The factory shocks and springs will not fit this setup.**

1. Raise the vehicle to a safe and comfortable working height. Use jack stands to support the vehicle with the suspension hanging freely.
2. Support the axle and remove the leaf springs, shocks and tail pipes. Refer to the factory service manual for proper disassemble procedures. You might have to detach the fuel line from the frame rails.



Cradle Installation

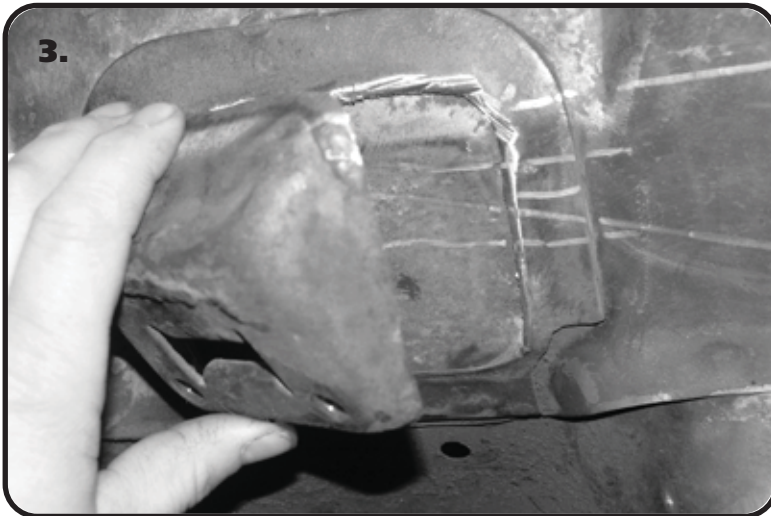

3. Remove the Factory Pinion Snubber and Mount from the car. We use a cut off wheel to remove the mount. Notice that we left the mounting lip of the mount attached to the car. This provides another layer of metal for the Front Tab of the Upper Cradle to attach too.

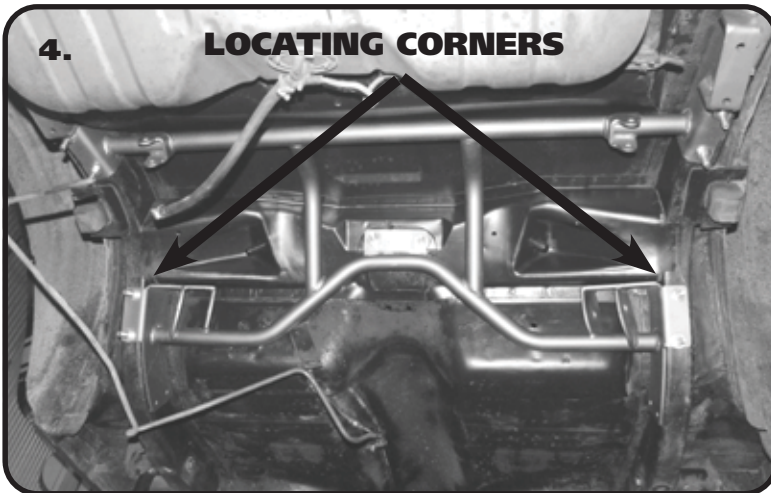

4. Install the cradle into the car. The rear corners of the Upper Bar Mounts locate into the front corner of the factory shock sheet metal mount. The Cradle is held in by (7) 3/8" Square U-bolts. Use the Cradle as a locator for drilling the holes. Drill the holes using a 7/16" drill bit. Drill The front 3 holes on each side with a 5/16" drill bit.

Note: The OEM fuel line will need to be detached from the frame rails until the Cradle is installed.



5. You will notice that the holes are drilled in pairs. Each pair will receive a Square U-bolt. To insert the Square U-bolts into the holes it may be necessary to lower the Cradle to install them. The U-bolts are installed by inserting one end into one of the drilled holes, using the other end as a handle, feed it through the frame until the inserted end will drop down through the remaining hole. Do this for all (7) U-bolts. Install the Cradle into position. Install (1) 3/8" Flat washer and (1) 3/8" Nylok nut onto each stud sticking through the cradle. Do not tighten them until all Washers and Nuts are installed. Install the 3/8" Thread Forming bolts into the 5/16" holes.



Lower Axle Mount & Lower Bar Installation

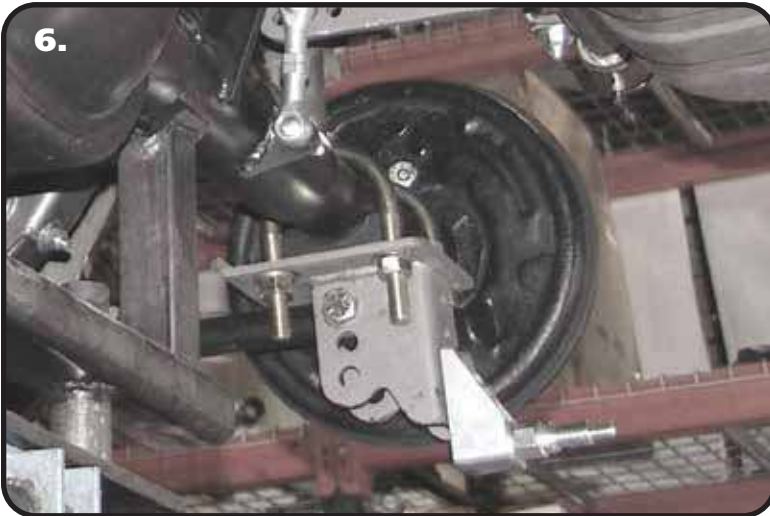

6. Install the Lower Axle Mount onto the Axle using the supplied U-Bolts. Run the nuts down to hold the mount in place, but **DO NOT** tighten yet.

NOTE: If your car is equipped with a differential that has the axle tubes swedged to 2 1/4", you will need (4) 99566009 u-bolts.

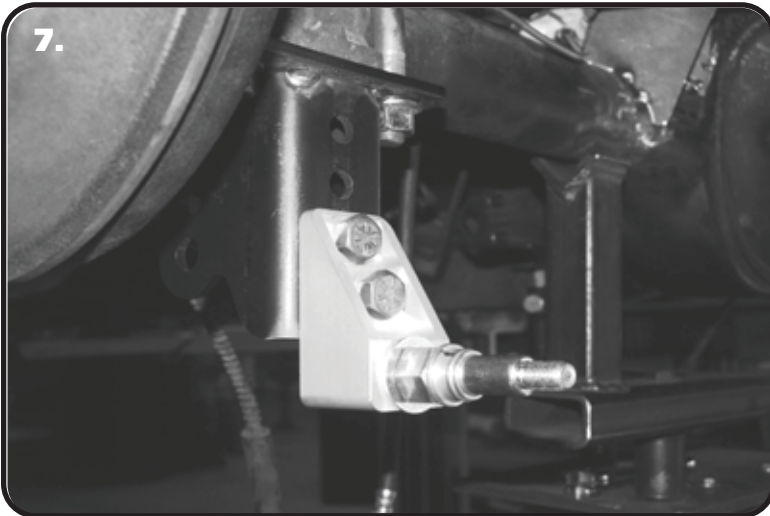

7. Attach the Lower Shock Mount to the Axle Mount using (1) 1/2"-20 x 1 1/4", (1) 1/2"-20 x 1 3/4" Hex Bolts, and (2) 1/2"-20 Nylok Nuts on each mount. The Shock Mount is installed in the **BOTTOM 2** holes of the Axle Mount. Install a Shock Stud and 5/8" washer in each Shock Mount. Tighten the mounting hardware and the Shock Stud.



8. Install the Lower Bars. The Front Lower uses the **WIDE**(70013767) R-Joint Spacers inserted into each side of the R-Joint. The Axle end of the bar gets a **NARROW**(70013334) R-Joint Spacer inserted into each side of the R-Joint. The bar is attached to the Axle Mount in the **TOP HOLE** using (1) 5/8" x 2 3/4" Hex Bolt, and (1) 5/8" Thin Nylok Jam Nut. The front of the Lower Bar is attached with 1/2"x 6" Hex Bolt(64-67) or 1/2"x 4 1/2"Hex Bolt(68-70), and (1) 1/2" Nylok Nut.



Setting Pinion Angle

READ PAGES 6-8 ON SETTING PINION ANGLES, UPPER BAR TAB JIG INSTALLATION, & SETTING RIDE HEIGHT.

How do you set the pinion angle? On a single-piece shaft you want to set it up where a line drawn through the center of the engine crankshaft or output shaft of the transmission and a line drawn through the center of the pinion are parallel to each other but not the same line.

Your transmission angle should be around 3 degrees down in the rear. If it is more or less than 3 degrees, you might want to consider changing it. Too little angle on the transmission reduces the amount of oil getting to the rear bushing. Too much transmission angle will increase the working angles of the u-joints which will increase the wear. With the transmission at 3 degrees down in the rear, you will want to set the pinion 3 degrees up in the front.

A simple way to do this is to place a digital angle finder or dial level on the front face of the lower engine pulley or harmonic balancer. This will give you a reading that is 90 degrees to the crank or output shaft unless you have real problems with your balancer. At the other end, you can place the same level or angle finder against the front face of the pinion yoke that is also at 90 degrees to the centerline. If you rotate the yoke up or down so both angles match, you have perfect alignment.

Road testing will tell you if you have it right. If you accelerate and you get or increase a vibration, then the pinion yoke is too HIGH. Rotate it downward in small increments of a degree or two until the problem goes away. If you get or increase a vibration when decelerating, then the pinion yoke is too LOW. Rotate it upward to correct it.

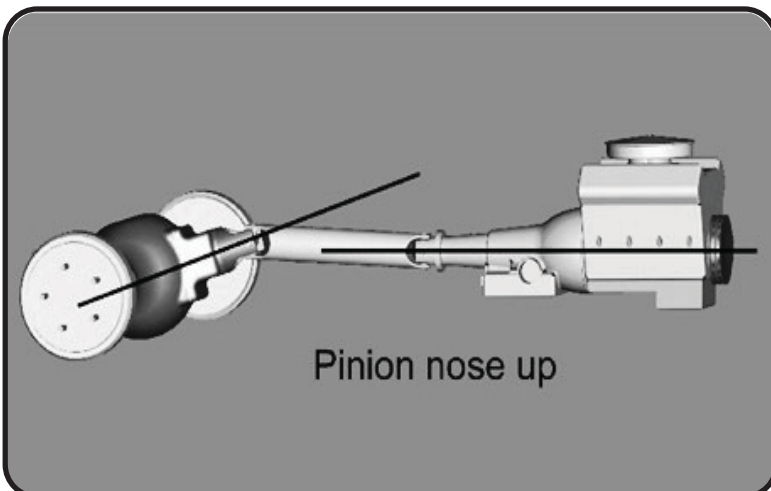
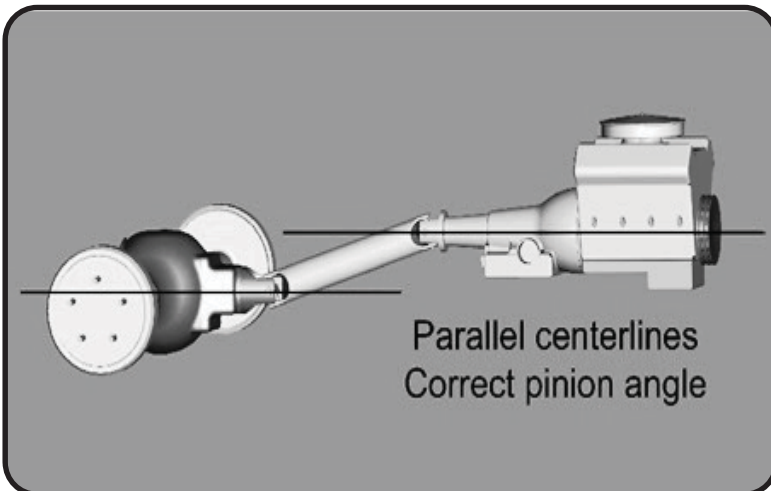
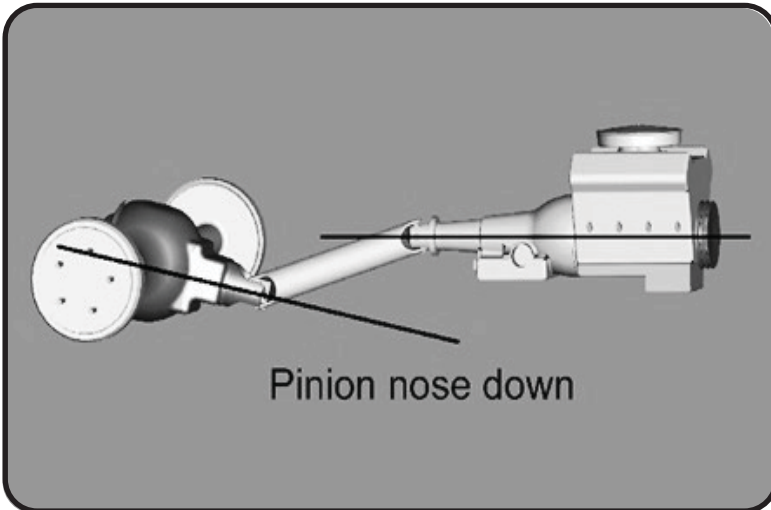



Upper Bar Tab Installation Jig

Upper Bar Installation Jig

- This jig has been supplied to aid in the installation of the upper 4 link bar. It can be temporarily used to properly align, locate and weld the tabs onto the axle. It will also ensure that the mounting bolts are parallel to the ground.
- Follow the diagram below to set the jig to the same length as the upper bar, use the 3/8" x 3/4" bolt and nuts to set the length.
- Position the axle at ride height. Center the axle left to right between the quarter panels. Set pinion angle.
- Bolt one end of the jig to the cradle using a 5/8" x 2 3/4" bolt.
- Using another 5/8" x 2 3/4" bolt, fasten the axle tabs to the other end. The tall tab goes to the outside of the car. The short tab goes to the inside of the car (some cars may need a tall tab on the inside). The tabs must be bolted to the outside of the jig.
- Swing the bar down letting the tabs rest onto the axle. Trim the brackets as necessary to minimize the gap to be welded.
- Check pinion angle, ride height and axle center. Tack-weld the tabs in place.
- Remove jig and install upper bar.
- Repeat this process for the other side.
- Recheck pinion angle, ride height and axle center. (Sound familiar?)
- After the tabs have been tack welded on both sides, remove the upper bars to avoid melting the rubber bushings. Let the axle drop down for better access to the tabs. Lay 1" welds on the inside and outside of the tabs. Skip around from one side to the other to avoid overheating the tube.

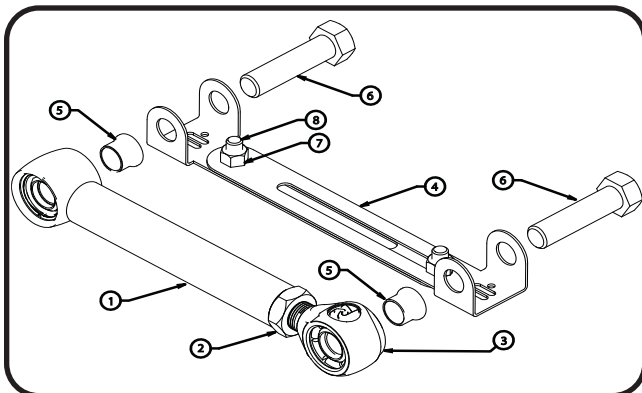

| Item# | Description |
|-------|---------------------|
| 1 | Upper Bar |
| 2 | 3/4"-16 Jam Nut |
| 3 | R-Joint End |
| 4 | Alignment Jig |
| 5 | Aluminum Spacer |
| 6 | 5/8" x 2 3/4" Bolt |
| 7 | 3/8"-16 Nut |
| 8 | 3/8"-16 x 3/4" Bolt |



Installing Axle Tabs

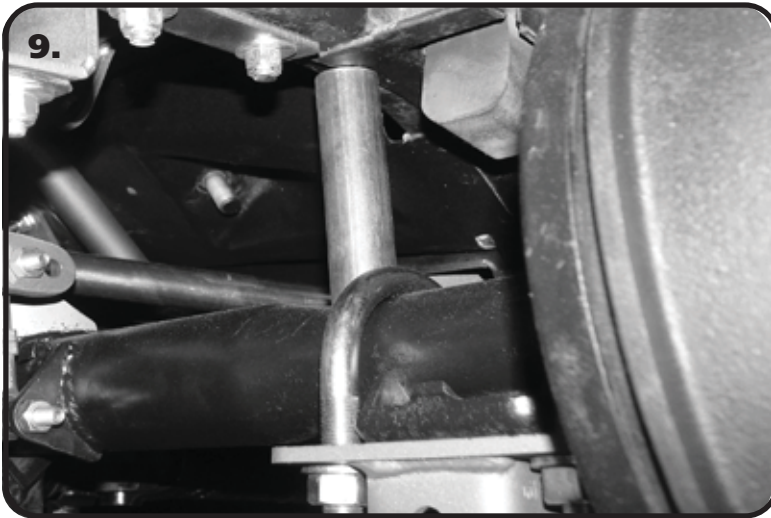

9. One helpful trick to maintain ride height when setting the pinion angle is to put a spacer between the axle and the frame. The spacer should be 4 1/2" tall. Set the pinion Angle and axle center. When measuring the axle center you can measure off of the frame rails. We also use a plum bob off the quarter panels to double check the axle center. Refer to Page 6 on Setting the Pinion Angle.

Note: You can tack weld the spacer in place after you get the Pinion Angle, and Axle Center set. This will ensure that nothing moves through the Upper Tab Installation.

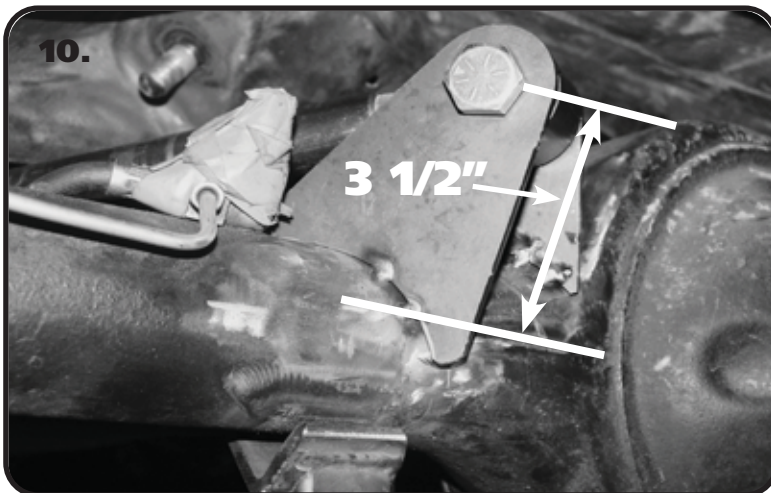

10. Refer to Page 7 and set the length of the Upper Bar Jig and install the Tabs on the Jig. Insert the Jig into the Cradle. Set the Upper Tabs on the Rearend. Due to different variations of the Rearend Housings, it may be necessary to modify the tabs for the best fit. The height you are wanting to achieve with the upper bar end is 3 1/2" from the axle center line. Modify the tabs so that the center of the bar bushing will be 3 1/2" from the center of the axle.

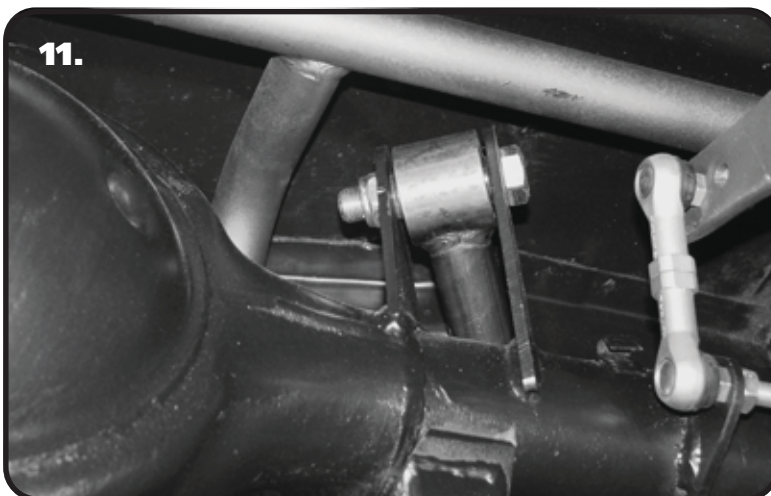

11. Once the bar end height is set, tack weld the tabs to the axle. Do this for the Driver and Passenger side bars. Insert the bars into the Cradle and Tabs to double check fitment. Recheck Axle Center and Pinion Angle. Once satisfied with fitment weld the Upper bar Tabs onto the Axle. Weld 1" at a time, skip around from one side to the other, and one tab to the other to avoid overheating the Axle Tube. When the tabs cool down, insert NARROW(70013334) spacers into each side of the R-Joints of the Upper Bar. Attach the upper bars using (1)5/8" x 2 3/4" Bolt, and (1) 5/8" Thin Nylok Nut.



Installing Shockwaves/Coilovers

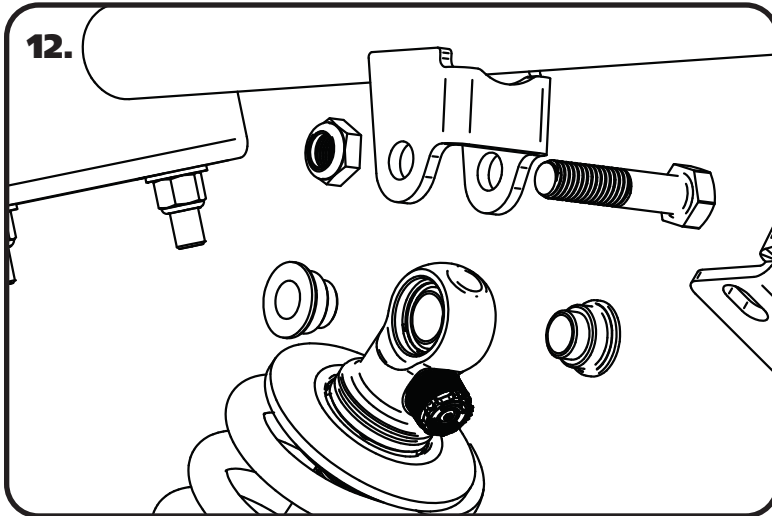

Remove the Spacer from between the Axle and Frame.

12. Install a 1/2" ID Spacer on each side of the upper Coilover/ShockWave. Slide the assembly into the upper crossmember from the bottom side. If your shock has an adjuster knob position it so that the knob points toward the center of the car. Line up the hole in the spacers with the hole in the upper shock bridge and insert 1/2" x 2 1/2" bolt and install 1/2" Nylok nut.

NOTE: BEFORE INSTALLING SHOCKWAVES
The correct pinion angle must be set first. Failure to do so could result in damage to the ShockWave by the bag rubbing the Lower Axle Mount.

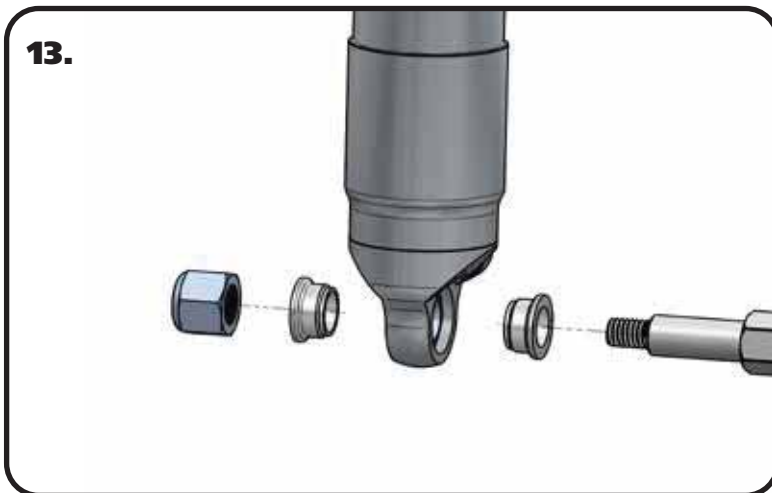

13. Install a 5/8" ID spacer(Small side towards shock body) onto the lower Shock Stud. Slide the bottom of the Shock onto the Stud. Install a second 5/8" ID Spacer onto the Stud(small side towards shock). You may need to jack the rearend up to Slide the Shock onto the Stud. Install the 7/16" Flat washer and 7/16" Nylok nut. Tighten the upper and lower shock bolts.

Note: If installing Shockwaves and you want to locate the air fitting in a different location, the air spring assembly can be rotated on the shock by grabbing the shock and air spring assembly by hand and spinning the shock in the air spring assembly.

The designed ride height of the CoilOver/Shockwave is 14 1/2" center to center.



Part # 12106510

1967-1970 Ford Mustang HQ Rear CoilOvers

Recommended Tools

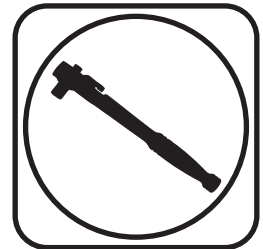
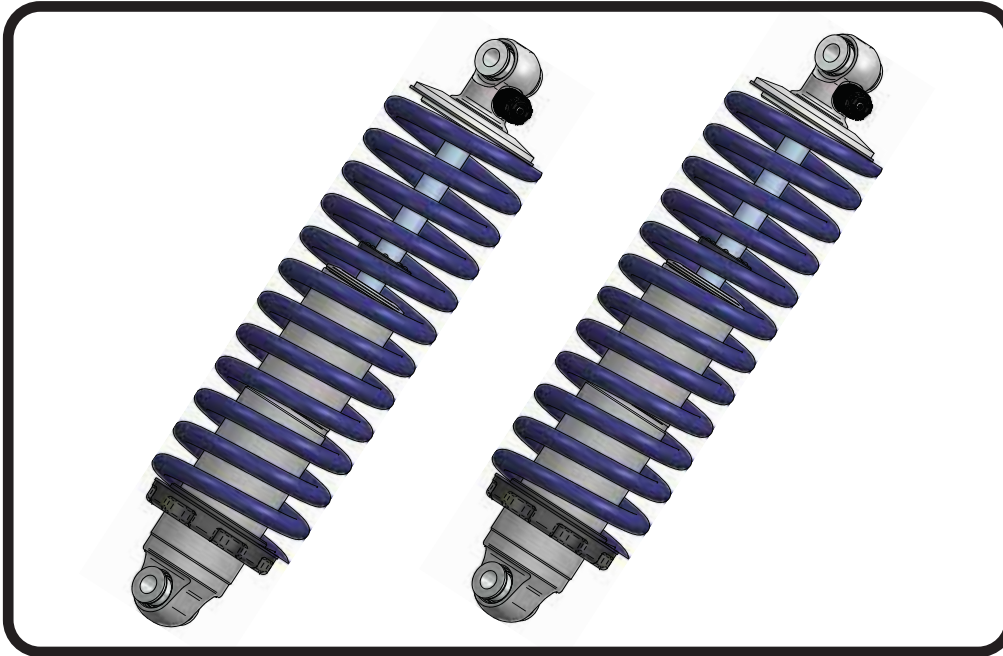

1967-1970 Ford Mustang HQ Series Rear CoilOvers

Installation Instructions

Table of contents

Page 30..... Included Components

Page 31..... Assembly and CoilSpring Adjustment

Page 32..... CoilSpring and Shock Adjustment

ShockWave Dimensions:

Center of bearing to Center of bearing:

Compressed: 11.23"

Ride Height: 14.50"

Extended: 16.43"





Major ComponentsIn the box

| Item # | Part # | Description | QTY |
|--------|-----------------|---|-----|
| 1 | 982-10-805 | 5.2" Stroke HQ Series Shock | 2 |
| 2 | 815-05-022-KIT | 1.7" Shock Eyelet | 2 |
| 3 | 803-00-109(kit) | Upper CoilSpring Retaining Plate (803-00-109 kit) | |
| 4 | 59120175 | CoilSpring 12" 175lb | 2 |
| 5 | 70010828 | Delrin Spring Washer | 4 |
| 6 | 803-00-109(kit) | Lower Spring Adjuster Nut (803-00-109 kit) | 2 |
| 7 | 803-00-109(kit) | Adjuster Nut Locking Screw (803-00-109 kit) | 2 |
| 8 | 803-00-109(kit) | Retaining Ring (803-00-109 kit) | 2 |
| 9 | 90002043 | 1/2" ID Upper Shock Bearing Spacer Half | 4 |
| | 90001994 | 5/8" ID Bearing (installed in shock and eyelet) | 4 |
| | 90001995 | Bearing Snap Ring (installed in shock and eyelet) | 8 |

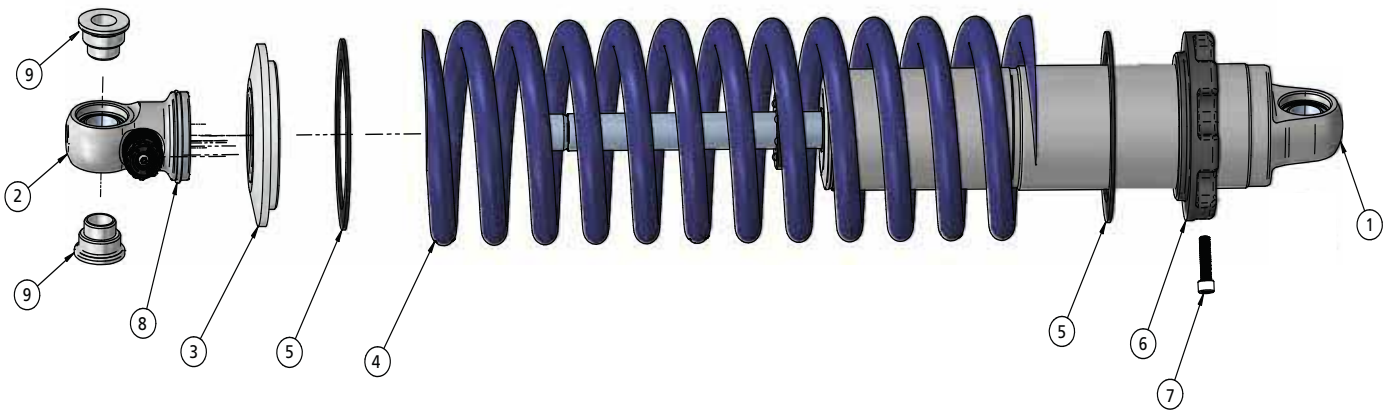



CoilOver Assembly...



1

First, using the supplied lower adjuster nut (803-00-199) thread the nut onto the shock from the bottom side as seen in figure 1. Remove the plastic pellet that is in the split of the adjuster nut.



4

Once the knob is removed slide a Delrin washer over the eyelet. Next, slide the upper spring mount (803-00-199) over eyelet as seen in figure 4.



2

Next, install a delrin washer then coil spring over the top of the shock as seen in figure 2.



5

Install upper spring mount retainer clip (803-00-199) into the groove on the upper eyelet as seen in figure 5. Then, reinstall adjuster to complete assembly.



3

Before the upper spring mount can be installed screw the adjuster knob on the upper eye mount to the firmest setting (clockwise) as seen in figure 3. Then remove the Knob by holding it while removing the center screw.

Install the locking screw in the adjuster nut before setting spring preload, but DO NOT tighten until the spring preload has been set.

NOTE: Remember to adjust the shock valving before driving, the shock is currently set to full stiff.

CoilSpring Adjustment

6. Preload the springs of the CoilOver 1" to start. **Steps 6a - 6e** will assist you with preloading the coil spring. You may need to adjust the amount of preload in the spring, but this will be determined after the vehicle has been sat on the ground.

6a. Verify the adjuster nut locking screw is installed in the adjuster nut, but not tight.

6b. Thread the spring adjuster nut up the shock body until it is snug against the spring. You should NOT be able to move the spring up and down on the shock (0 preload). Verify the upper coil spring cap is seated correctly on the upper shock stud.

6c. Measure from the bottom of the adjuster nut to the flat of the shock. You may want to write the measurement down.

6d. Using a spanner wrench, thread the adjuster up the shock an additional 1" (from the measurement you took in step 2) to preload the spring.

6e. Lock the adjusting nut in place by tightening the adjuster nut locking screw.

7. Reinstall the rear wheels and tires and set the rear of the vehicle back on the ground.

8. After entire weight of vehicle is on the wheels, jounce the suspension and roll the car forward and backward to alleviate suspension bind. **THIS IS NECESSARY BEFORE MEASURING RIDE HEIGHT.**



CoilSpring Adjustment

9. If you determine you need to adjust the ride height of the rear suspension after getting the vehicle on the ground, **Steps 9a - 9e** will assist you in adjusting the ride height.
 - 9a. Raise the vehicle and support it by the frame, allowing the suspension to hang freely. You do NOT need to remove the rear wheels.
 - 9b. Loosen the locking screw in the adjuster nut, but do not remove the locking screw.
 - 9c. Measure from the bottom of the adjuster nut to the flat of the shock. You may want to write the measurement down.
 - 9d. Using a spanner wrench, thread the adjuster up or down the shock to obtain the correct ride height. One complete revolution of the adjuster nut is approximately 1/16" at the wheel. Threading the adjuster nut up the shock will raise the ride height, threading it down will lower the ride height.
 - 9e. Lock the adjusting nut in place by tightening the adjuster nut locking screw.
10. After entire weight of vehicle is on the wheels, jounce the suspension and roll the vehicle forward and backward to alleviate suspension bind. **THIS IS NECESSARY BEFORE MEASURING RIDE HEIGHT.**
11. Recheck your ride height. If you need to readjust, repeat **Steps 9-10.**

Shock Adjustment 101- Single Adjustable

Rebound Adjustment:

How to adjust your new shocks.

The rebound adjustment knob is located on the top of the shock absorber protruding from the eyelet.

You must first begin at the ZERO setting, then set the shock to a medium setting of 12.



-Begin with the shocks adjusted to the ZERO rebound position (full stiff). Do this by rotating the rebound adjuster knob clockwise until it stops.

-Now turn the rebound adjuster knob counter clock wise 12 clicks. This sets the shock at 12. (settings 21-24 are typically too soft for street use).

Take the vehicle for a test drive.



-if you are satisfied with the ride quality, do not do anything, you are set!

-if the ride quality is too soft increase the damping effect by rotating the rebound knob clock wise 3 clicks.

Take the vehicle for another test drive.



-if the vehicle is too soft increase the damping effect by rotating the rebound knob clock wise 3 additional clicks.

-If the vehicle is too stiff rotate the rebound adjustment knob counter clock wise 2 clicks and you are set!

Take the vehicle for another test drive and repeat the above steps until the ride quality is satisfactory.

Note: One end of the vehicle will likely reach the desired setting before the other end. If this happens stop adjusting the satisfied end and keep adjusting the unsatisfied end until the overall ride quality is satisfactory.